



# DAGNALL ELECTRONICS LIMITED

Shuttleworth Road, Elms Industrial Estate, Bedford. MK41 0EP UK  
 TEL +44(0)1234 330077 FAX +44(0)1234 330088  
 E-mail sales@dagnall-electronics.com

Iss 1 25/10/02

1 of 2

## PRODUCT DATASHEET

### 4VA LOW PROFILE ENCAPSULATED TRANSFORMER

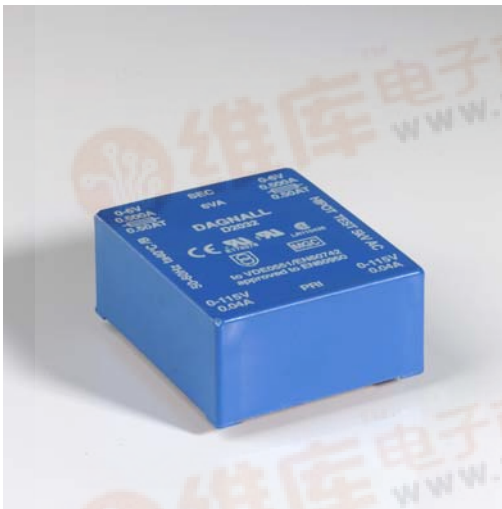

- DE Independantly Approved to  
**EN60950 UL506 cUL506 & CSA 22.2**
- DE CE Marked
- DE Dual 115V Primaries
- DE Comprehensive choice of secondary voltages
- DE 5KV Isolation between primary and secondary windings.
- DE UL94-V0 Vacuum Encapsulated Construction
- DE Suitable for flow soldering
- DE Identical footprint from 2VA to 9VA

Weight	0.145	Kg	Approvals  EN c
Typical Regulation	30	%	
Frequency	50/60	Hz	
Max Ambient	40	°C	
Bobbin Material	UL94-V0	"B" 130 °C	

Part No	Primary	Secondary	Secondary Fuse
D2088	115+115	6+6	0.315AT
D2089	115+115	9+9	0.200AT
D2090	115+115	12+12	0.160AT
D2796	115+115	18+18	0.125AT
D2797	115+115	24+24	0.080AT

Please see sheet 2 for outline drawing and connection info.

# DAGNALL ELECTRONICS LIMITED

Shuttleworth Road, Elms Industrial Estate, Bedford. MK41 0EP UK

TEL +44(0)1234 330077 FAX +44(0)1234 330088

E-mail sales@dagnall-electronics.com

Issue 1. 25/10/02

2 of 2

## PRODUCT DATASHEET

### 4VA Approved Low Profile Encapsulated Transformer

Outline Drawing

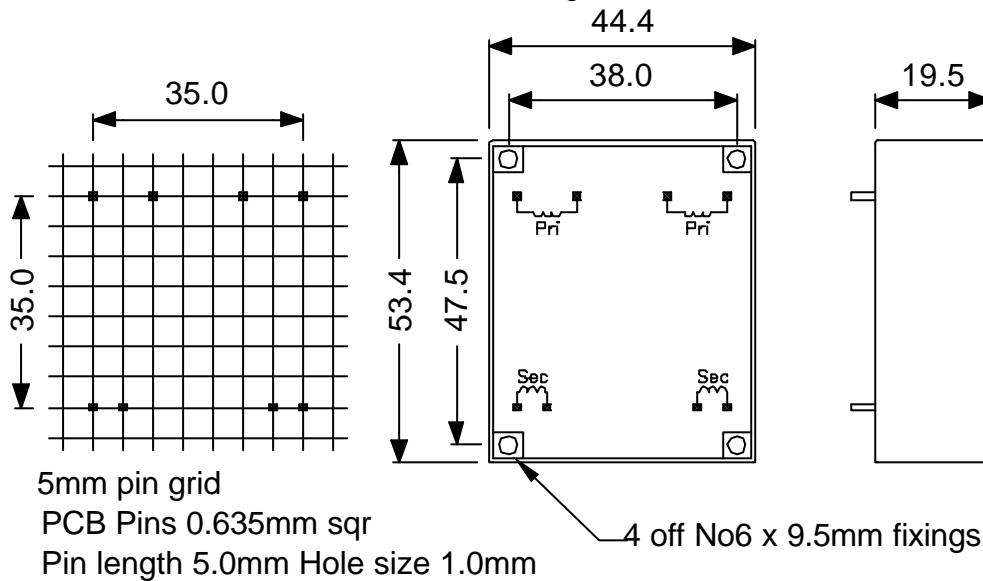

Connection Diagrams for D2088 - 230V supply

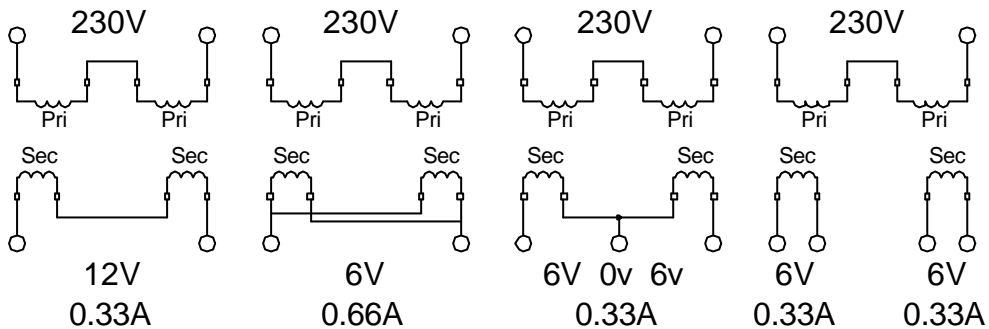

Connection Diagrams for D2088 - 115V supply

