



General Description:

The Durel® D340B is part of a family of highly integrated EL drivers based on Durel's patented three-port (3P) topology, which offers built-in EMI shielding. This low-cost, regulated device is well suited for backlighting timepieces and small liquid crystal displays for portable electronic applications.



Features

- Small System Footprint
- Regulated AC output voltage
- Low Standby Current
- High Efficiency

Applications

- Timepieces
- Pagers
- Calculators
- Handsets

Lamp Driver Specifications:

(Using Standard Test Circuit at Ta=25 °C unless otherwise specified.)

Parameter	Symbol	Minimum	Typical	Maximum	Unit	Conditions
Standby Current			5	1000	nA	E' = V+
Supply Current	I		12	20	mA	E' = GND
Output Voltage	Vout	110	144	160	Vpp	E' = GND
Lamp Frequency	LF	100	140	200	Hz	E' = GND

Standard Test Circuit

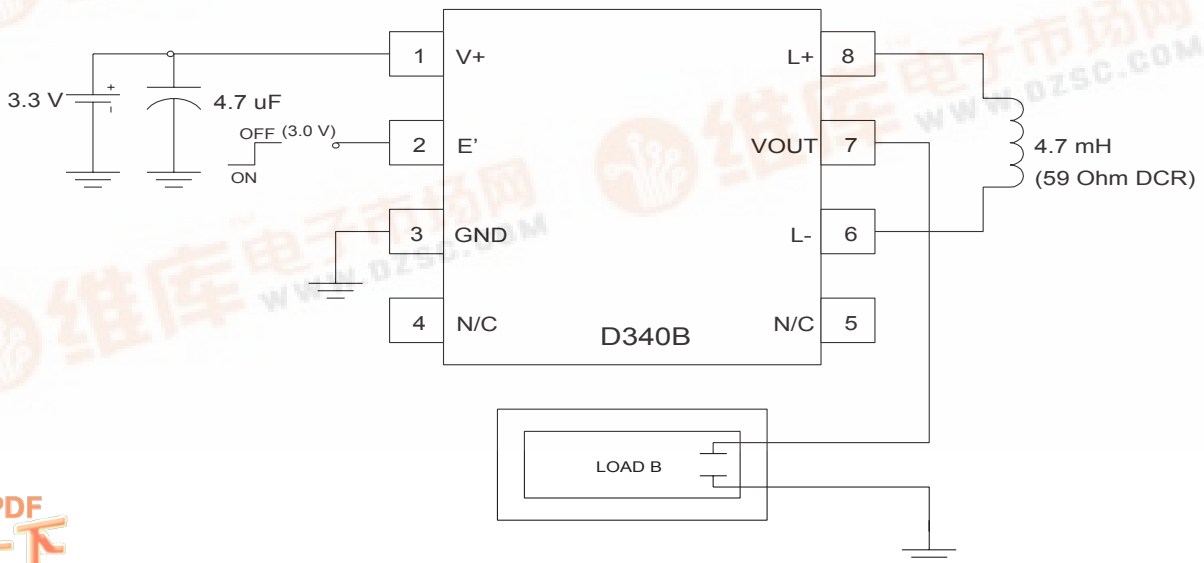

Load A*

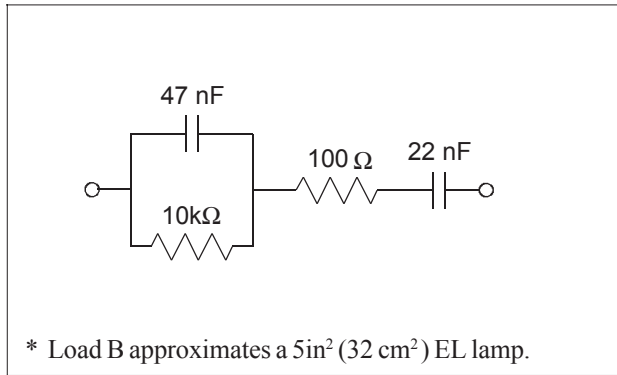

Typical Output Waveform

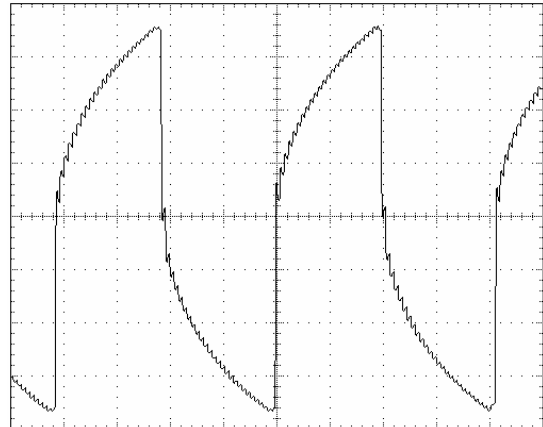

Absolute Maximum Ratings:

Parameter	Symbol	Minimum	Maximum	Unit	Comments
Supply voltage					
Operating Range	V+	1.0	7.0	V	E = GND
Withstand Range		-0.5	10.0		E = V+
Enable Voltage	E	-0.5	(V+)+0.5	V	
Output Voltage	V _{OUT}		160	V _{pp}	Peak-to-Peak Voltage
Operating Temperature	T _a	-40	70	°C	
Storage Temperature	T _s	-40	150	°C	

Note: The above are stress ratings only. Functional operation of the device at these ratings or any other above those indicated in the specifications is not implied. Exposure to absolute maximum rating conditions for extended periods of time may affect reliability.

Physical Data:

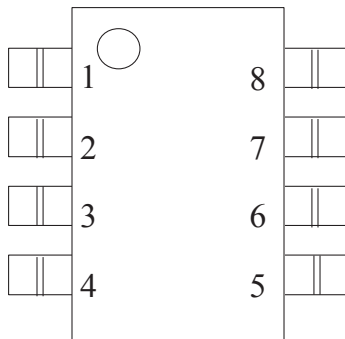

PIN #	NAME	FUNCTION
1	V+	DC power supply input
2	E	System enable; Power Down Control
3	GND	System ground connection
4	N/C	No connection
5	N/C	No connection
6	L-	Negative input to inductor
7	V _{OUT}	High voltage AC output to lamp
8	L+	Positive input to inductor

Note: Please consult factory for bare die dimensions and bond pad locations.

Typical Performance Characteristics Using Standard Test Circuit

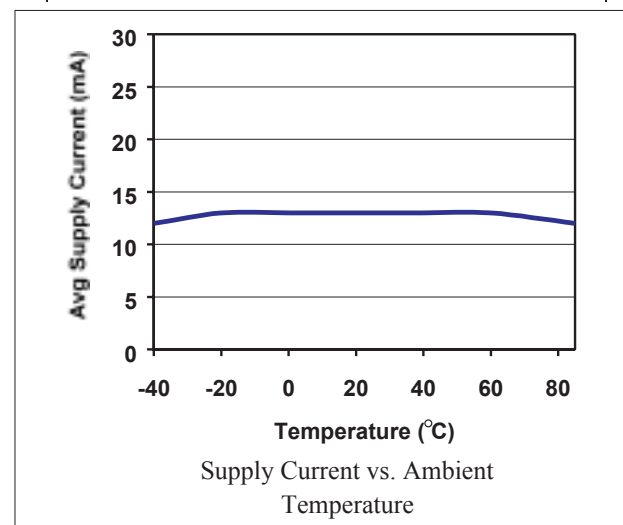
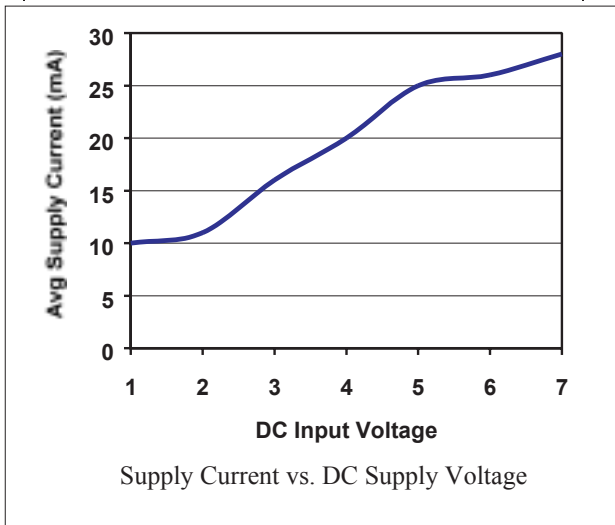
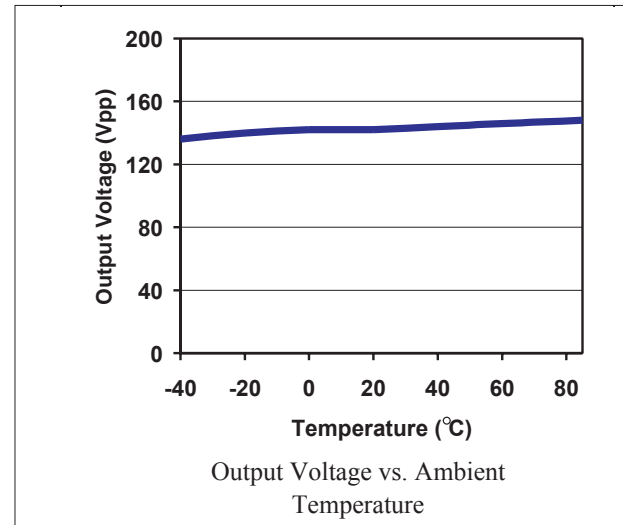
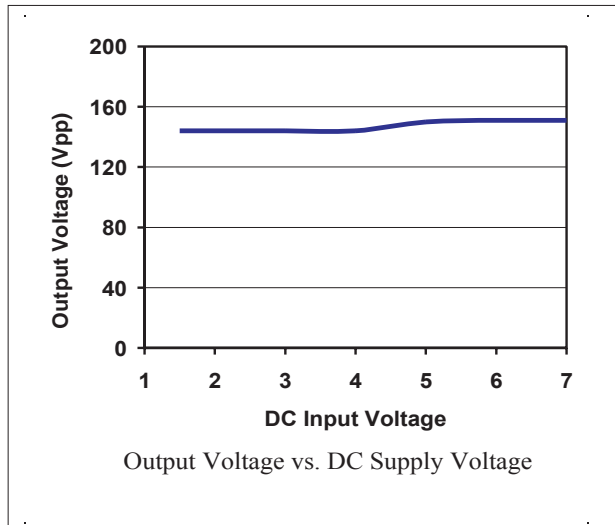
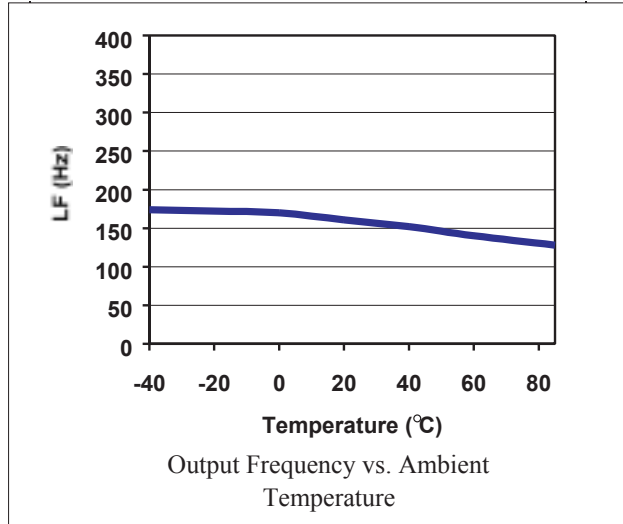
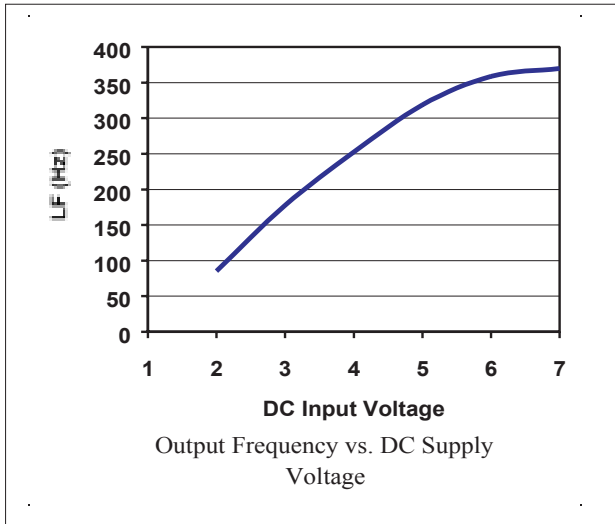

Block Diagram of the Driver Circuitry

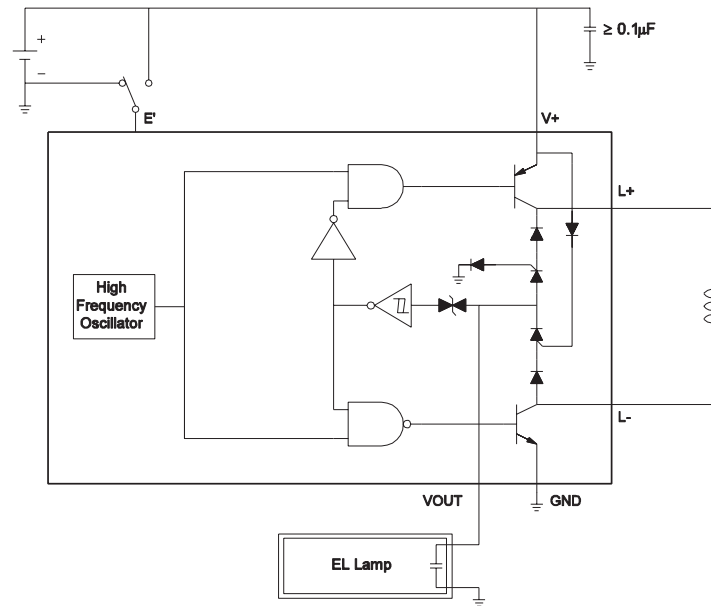

Theory of Operation

Electroluminescent (EL) lamps are essentially capacitors with one transparent electrode and a special phosphor material in the dielectric. When a strong AC voltage is applied across the EL lamp electrodes, the phosphor glows. The required AC voltage is typically not present in most systems and must be generated from a low voltage DC source. Thus, Durel developed its patented Three-Port (3P) switch-mode inverter circuit to convert the available DC supply to an optimal drive signal for high brightness and low-noise EL lamp applications. The Durel 3P topology offers the simplicity of a single DC input, single AC output, and a shared common ground that provides an integrated EMI shielding.

The D340B drives the EL lamp by repeatedly pumping charge through an external inductor with current from a DC source and discharging into the capacitance of the EL lamp load. With each high frequency (HF) cycle the voltage on the lamp is increased. When the voltage on the lamp reaches the set voltage on the comparator, the voltage on the lamp is discharged to ground and the polarity of the inductive charging is reversed. By this means, an alternating positive and negative voltage is developed at the single output lead of the device to one of the electrodes of the EL lamp. The other lamp electrode is commonly connected to a ground plane, which can then be considered as electrical shielding for any underlying circuitry on the application.

The EL driving system is divided into several parts: on-chip logic and control, on-chip high voltage output circuitry, and off-chip components. The on-chip logic controls the inductor switching frequency (HF) and change in lamp charging polarity at a frequency (LF) that is dependent on the lamp load size and DC voltage source. These signals are combined and buffered to regulate the high voltage output circuitry. The output circuitry handles the power through the inductor and delivers the high voltage to the lamp. The selection of off-chip components provides a degree of flexibility to accommodate various lamp sizes, system voltages, and brightness levels. Since a key objective for EL driver systems is to save space and cost, required off-chip components were kept to a minimum.

Durel provides a D340B Designer's Kit, which includes a printed circuit evaluation board intended to aid you in developing an EL lamp driver configuration using the D340B that meets your requirements. A section on designing with the D340B is included in this datasheet to serve as a guide to help you select the appropriate external components to complete your D340B EL driver system.

Typical D340B configurations for driving EL lamps in various applications are shown on the following page. The expected system outputs, such as lamp luminance, lamp output frequency and voltage and average supply current draw, for the various sample configurations are also shown with each respective figure.

Typical D340B EL Driver Configurations

1.5V Analog Watch

Typical Output

Luminance = 2.9 fL (10 cd/m²)
 Lamp Frequency = 214 Hz
 Supply Current = 10 mA
 Vout = 144 Vpp
 Load = 645 mm² (1 in²) Durel ®3 Green EL

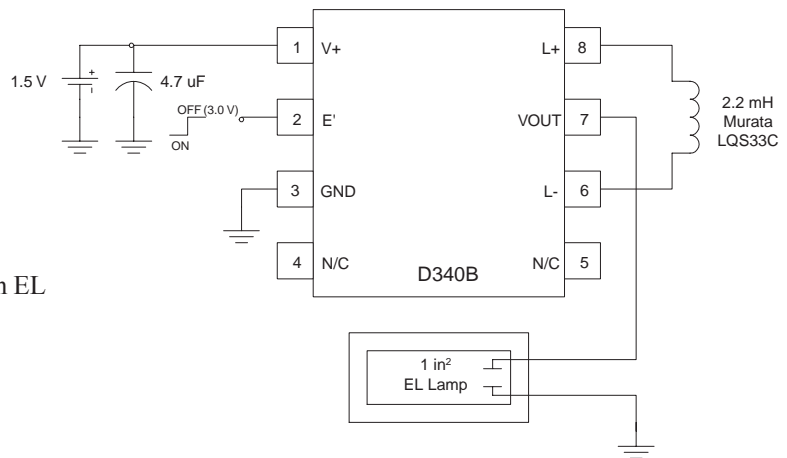

3.0V Pager or Digital Watch

Typical Output

Luminance = 4.7 fL (16 cd/m²)
 Lamp Frequency = 600 Hz
 Supply Current = 11 mA
 Vout = 140 Vpp
 Load = 645 mm² (1 in²) Durel ®3 Blue-Green EL

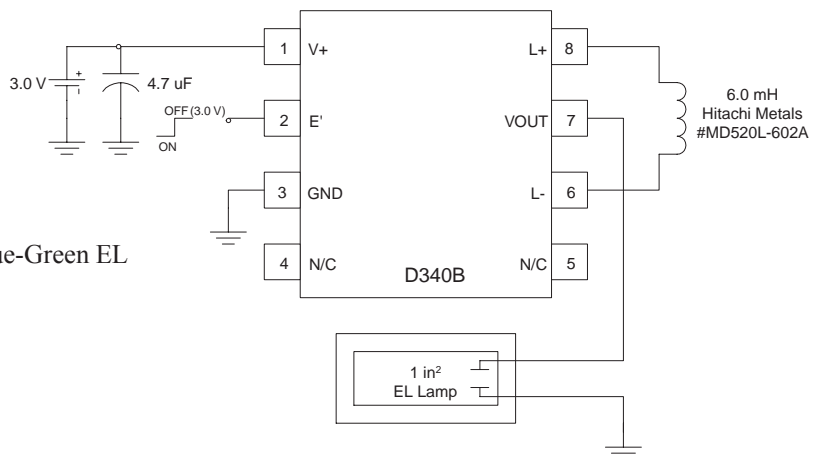

6.0V Remote Control

Typical Output

Luminance = 5.8 fL (20 cd/m²)
 Lamp Frequency = 530 Hz
 Supply Current = 16 mA
 Vout = 145 Vpp
 Load = 2580 mm² (4 in²) Durel ® 3 Green EL

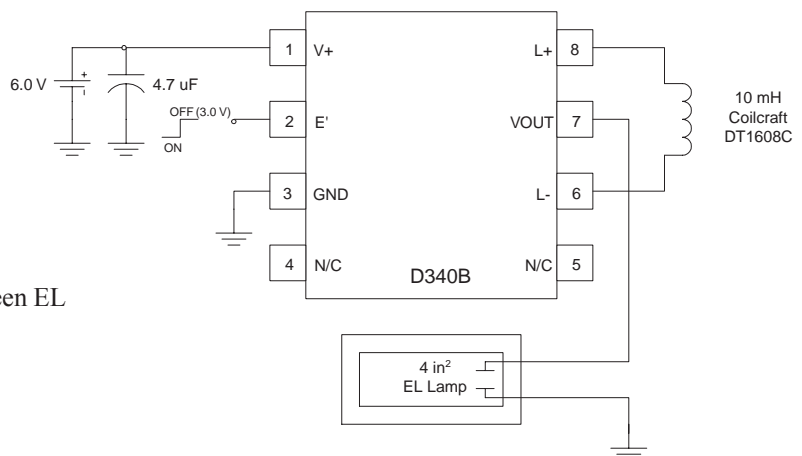

D340B Design Ideas

I. Driving Multi-Segment Lamps

The D340B may be used to drive two or more EL lamps or EL lamp segments independently. An external switching circuit can be used to turn each lamp segment on or off. A high signal at the E input for the corresponding EL lamp will power the segment when the IC is enabled. In this example, Segment 1 is always on when the Durel D340B is enabled. Otherwise, always make sure that at least one segment is switched on when the driver IC is activated.

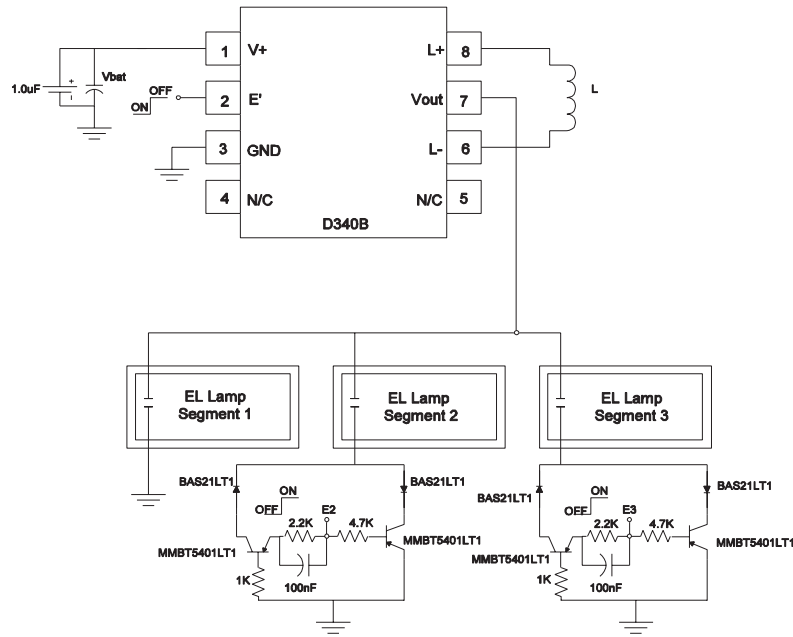

II. Enabling the D340B with a High Logic Signal

A low logic signal at the E' pin will enable the D340B. Adding a transistor and two resistors will allow the D340B to be enabled with a high voltage signal.

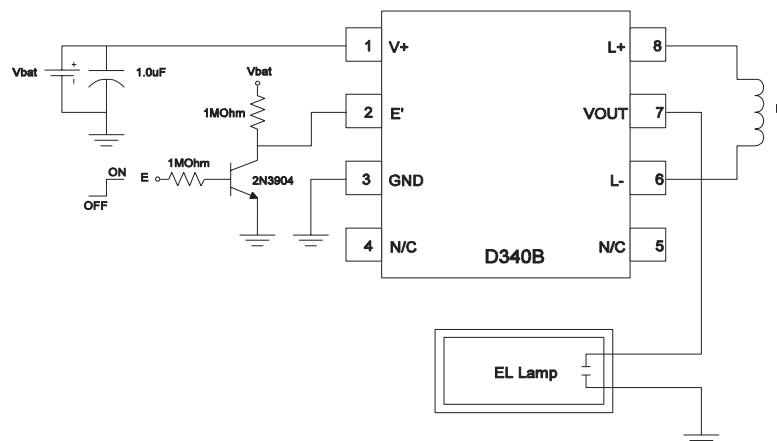

III. Two-Level Dimming

Toggle switching between two different EL lamp brightness levels may be achieved with the following circuit. When DIM is low, the external pnp transistor is saturated and the EL lamp runs at full brightness. When DIM is high, the external pnp turns off and the 47W resistor reduces the voltage at (V+) and dims the EL lamp.

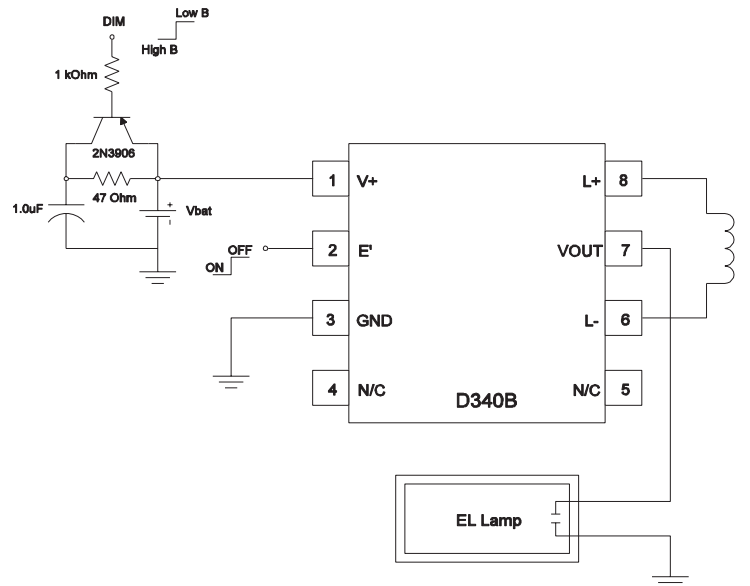

IV. Automatic Turn-Off After Short Time Delay

It is sometimes desirable for the EL lamp to turn off automatically after a few seconds of operation. Typically, a mechanical switch pulls E' low to initially turn on the device. When the switch is released, Cdelay keeps the D340B operating for a short period before turning off. The following table shows typical delay on-times.

C delay (uF)	Vbat	
	1.5V	3.0V
5	1.8 sec	2.4 sec
7	2.3 sec	3.1 sec
10	5.6 sec	7.8 sec
15	5.9 sec	9.0 sec
20	7.7 sec	11.2 sec

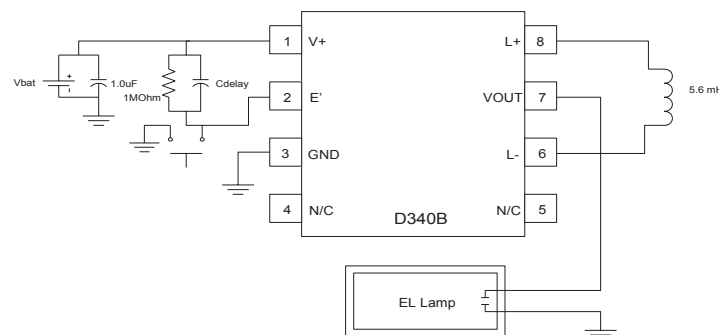

V. Automatic Turn-Off After Long Time Delay

Longer on-times can be achieved with the addition of an external transistor. Typically, a mechanical switch pulls E' low to initially turn on the device. When the switch is released, C_{delay} keeps the D340B operating for a period before turning off. The following table shows typical delay on-times using the following circuit with smaller capacitor values.

	V _{bat}	
C delay (uF)	1.5V	3.0V
1	8 sec	11 sec
2	16 sec	21 sec
3	25 sec	31 sec

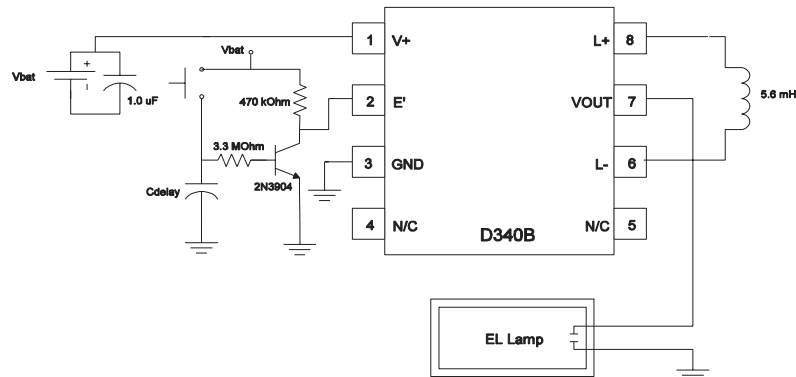

Ordering Information

The D340B IC is available as bare die in probed wafer form or in die tray, and in standard MSOP-8 plastic package in tape and reel. A Durel D340B Designer's Kit (1DDD340BB-K01) provides a vehicle for evaluating and identifying the optimum component values for any particular application using D340B. Durel engineers also provide full support to customers, including specialized circuit optimization and application retrofits.

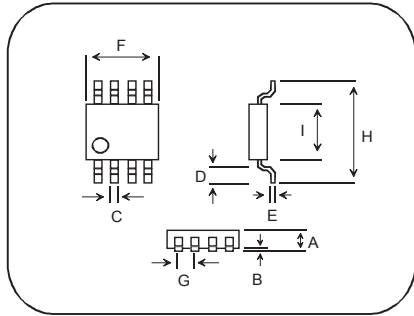

Description	MSOP-8					
	Min.		Typical		Max.	
	mm.	in.	mm.	in.	mm.	in.
A	0.94	0.037	1.02	0.040	1.09	0.043
B	0.05	0.002	0.10	0.004	0.15	0.006
C	0.20	0.008	0.33	0.013	0.46	0.018
D	0.41	0.016	0.53	0.021	0.65	0.026
E	0.13	0.005	0.18	0.007	0.23	0.009
F	2.84	0.112	3.00	0.118	3.15	0.124
G	0.43	0.017	0.65	0.026	0.83	0.033
H	4.70	0.185	4.90	0.193	5.11	0.201
I	2.84	0.112	3.00	0.118	3.25	0.128

MSOPs are marked with part number (340B) and 3-digit wafer lot code. Bottom of marking is on the Pin 1 side.

RECOMMENDED PAD LAYOUT

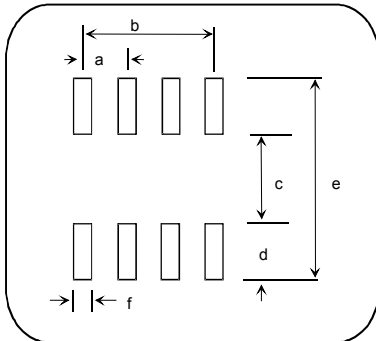

	MSOP-8 PAD LAYOUT					
	Min.		Typical		Max.	
	mm.	in.	mm.	in.	mm.	in.
a	0.60	0.0236	0.6	0.0256	0.70	0.0276
b	1.90	0.0748	1.9	0.0768	2.00	0.0788
c	3.3	0.130			3.45	0.136
d	0.89	0.035	0.9	0.038	1.05	0.041
e	5.26	0.207			5.41	0.213
f	0.41	0.016	0.4	0.018	0.51	0.020

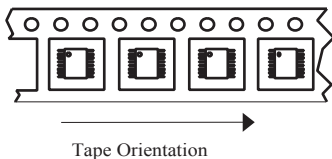

MSOPs in Tape and Reel:

1DDD340BB-M02

Embossed tape on 360 mm diameter reel per EIA-481-2.
2500 units per reel. Quantity marked on reel label.

ISO 9001 Certified

DUREL Corporation

2225 W. Chandler Blvd.

Chandler, AZ 85224-6155

Tel: (480) 917-6000

FAX: (480) 917-6049

Website: <http://www.durel.com>

The DUREL name and logo are registered trademarks of DUREL CORPORATION.

This information is not intended to and does not create any warranties, express or implied, including any warranty of merchantability or fitness for a particular purpose. The relative merits of materials for a specific application should be determined by your evaluation.

The EL driver circuits herein are covered by US patent #5,313,141. Corresponding foreign patents are issued and pending.