

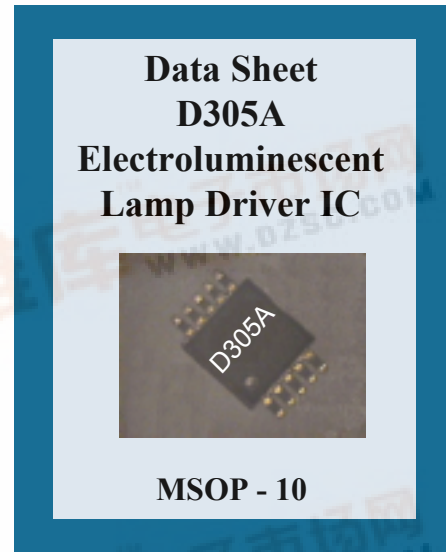

General Description

The Durel® D305A is a high-power IC inverter intended for driving EL lamps as large as 100 cm². The D305A IC is equipped with many control functions, including: wave-shaping™ programmability for minimizing audible noise, and features that allow for component cost-savings, precision control of frequencies, and stability of lamp color over wide temperature extremes.



Features

- High AC Voltage Output to 400Vpp
- Very Low Standby Current
- Flexible Wave-shaping Capability
- External Clock Compatible
- Small MSOP-10 Package

Applications

- White EL Lamp Backlight for Color LCD
- Wireless Handset
- PDA
- GPS
- Other Handheld Portable Electronics

Lamp Driver Specifications

(Using Standard Test Circuit at Ta=25 °C unless otherwise specified.)

Parameter	Symbol	Minimum	Typical	Maximum	Unit	Conditions
Standby Current			1	5	µA	E = GND
Supply Current	I _{bat}	85	99	115	mA	E = V _{cc}
Logic Supply Current	I _{cc}	16	17	19	mA	E = V _{cc}
Output Voltage	V _{out}	264	297	330	V _{pp}	E = V _{cc}
Lamp Frequency	LF	425	473	525	Hz	E = V _{cc}

Standard Test Circuit

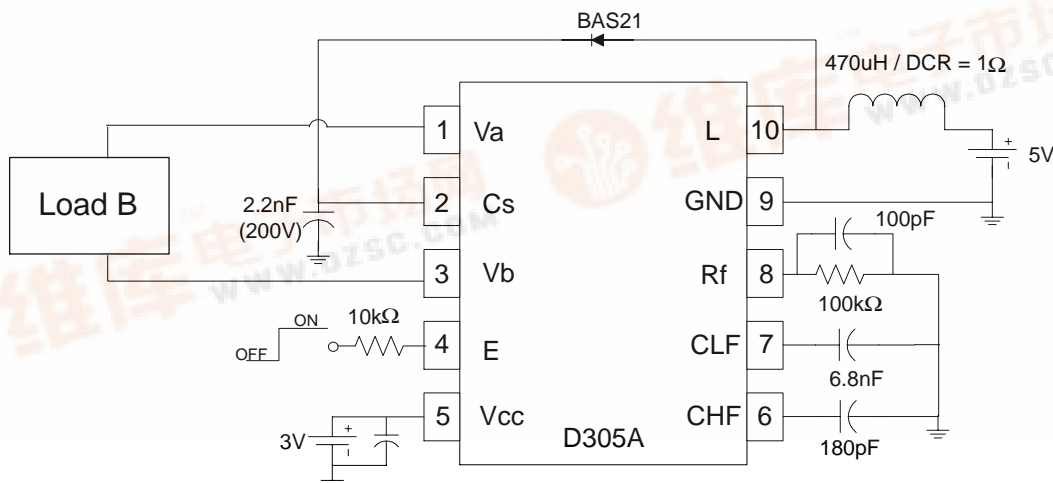

Load B*

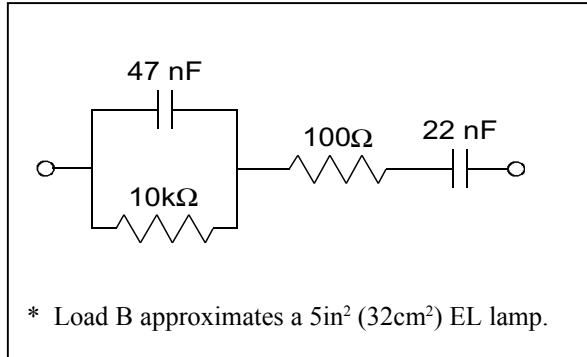

Typical Output Waveform

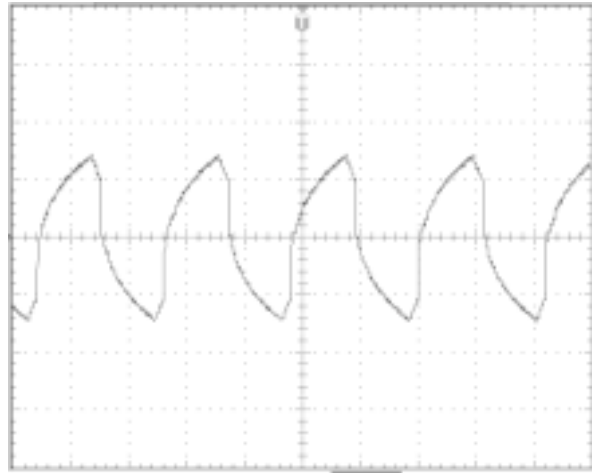

Absolute Maximum Ratings

Parameter	Symbol	Minimum	Maximum	Unit	Comments
Supply Voltage					
Operating Range	V _{bat}	2.0	7.0	V	E = V _{cc}
Withstand Range		-0.5	16		E = GND
Logic Drive Voltage					
Operating Range	V _{cc}	2	5	V	E = V _{cc}
Withstand Range		-0.5	6		E = GND
Enable Voltage	E	-0.5	V _{cc} + 0.5	V	
V _{out}	V _a - V _b		410	V _{pp}	E = V _{cc}
Operating Temperature	T _a	-40	85	°C	Ambient
Operating Temperature	T _j		125	°C	Junction
Average Thermal Resistance	θ _{jA}		113	°C/W	Junction to Ambient
Storage Temperature	T _s	-55	150	°C	

Note: The above are stress ratings only. Functional operation of the device at these ratings or any other above those indicated in the specifications is not implied. Exposure to absolute maximum rating conditions for extended periods of time may affect reliability.

Physical Data

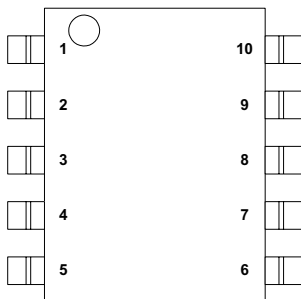

PIN #	NAME	FUNCTION
1	V _a	AC voltage output to EL lamp
2	C _s	High voltage storage capacitor input
3	V _b	AC voltage output to EL lamp
4	E	System enable; Wave-shaping resistor control
5	V _{cc}	Logic drive voltage
6	CHF	Capacitor input to high frequency oscillator
7	CLF	Capacitor input to low frequency oscillator
8	R _f	Resistor input for frequency control
9	GND	Power ground
10	L	Inductor input

Typical Performance Characteristics Using Standard Test Circuit

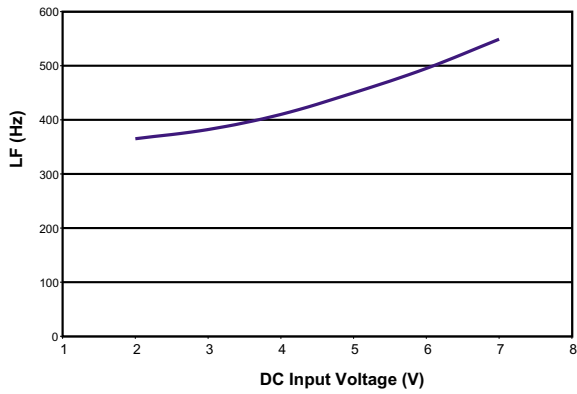

Output Frequency vs. DC Supply Voltage

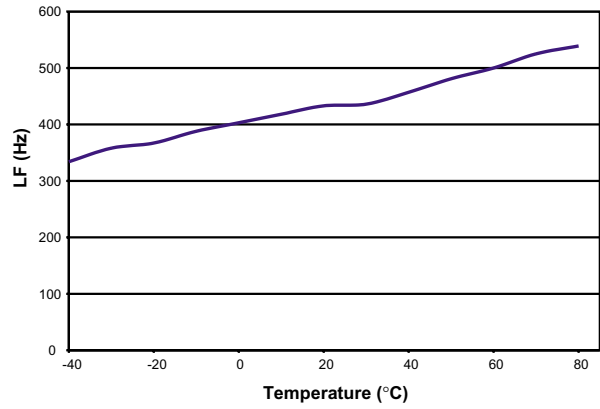

Output Frequency vs. Ambient Temperature

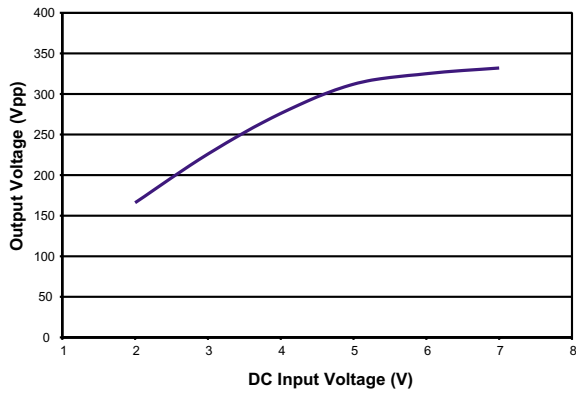

Output Voltage vs. DC Supply Voltage

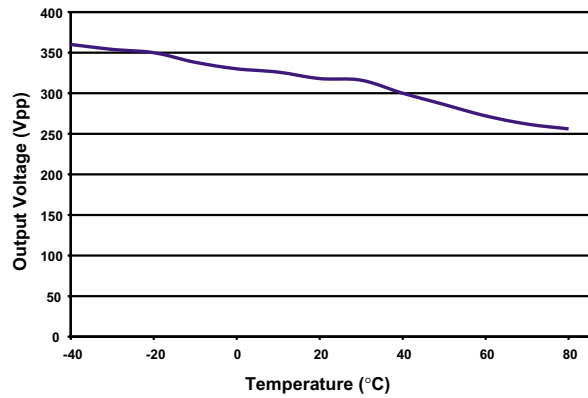

Output Voltage vs. Ambient Temperature

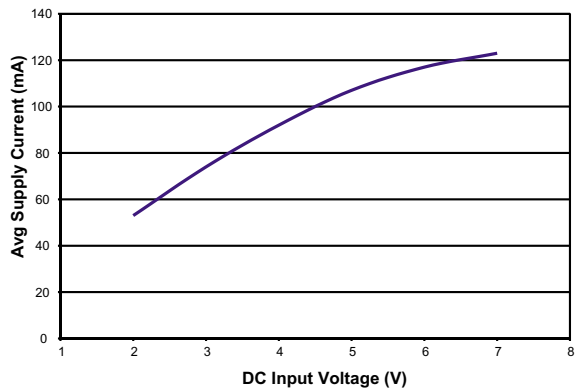

Supply Current (Ibat) vs. DC Supply Voltage

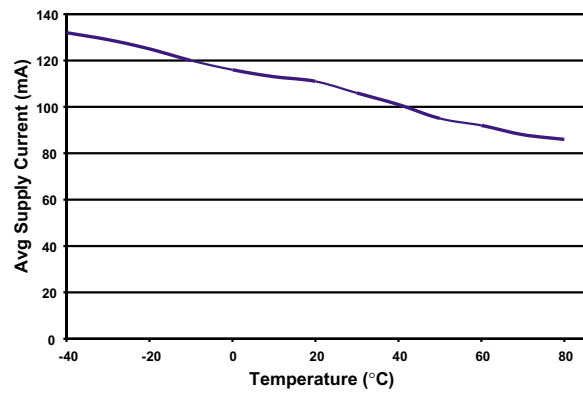

Supply Current (Ibat) vs. Ambient Temperature

Block Diagram of the Driver Circuitry

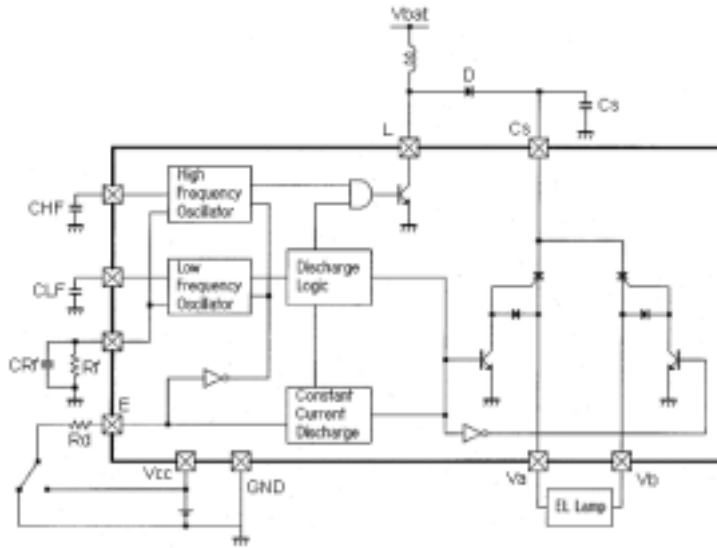

Theory of Operation

Electroluminescent (EL) lamps are essentially capacitors with one transparent electrode and a special phosphor material in the dielectric. When a strong AC voltage is applied across the EL lamp electrodes, the phosphor glows. The required AC voltage is typically not present in most systems and must be generated from a low voltage DC source.

The D305A IC inverter drives the EL lamp by using a switching transistor to repeatedly charge an external inductor and discharge it to the high voltage capacitor C_s . The discharging causes the voltage at C_s to continually increase. The internal circuitry uses the H-bridge technology, using both electrodes to drive the EL lamp. One of the outputs, V_a or V_b , is used to discharge C_s into the EL lamp during the first half of the low frequency (LF) cycle. By alternating the state of the H-bridge, the other output is used to charge the EL lamp during the second half of the LF cycle. The alternating states make it possible to achieve 400V peak-to-peak across the EL lamp.

The EL driving system is divided into several parts: on-chip logic control, on-chip high voltage output circuitry, on-chip discharge logic circuitry, and off-chip components. The on-chip logic controls the lamp operating frequency (LF) and the inductor switching frequency (HF). These signals are used to drive the high voltage output circuitry (H-bridge) by delivering the power from the inductor to the lamp. The integrated discharge logic circuitry uses a patented wave shaping technique for reducing audible noise from an EL lamp. Changing the R_d value changes the slope of the linear discharge as well as the shape of the waveform. The off-chip component selection provides a degree of flexibility to accommodate various lamp sizes, system voltages, and brightness levels.

Typical D305A EL driving configurations for driving EL lamps in various applications are shown on the following page. The expected system outputs for the various circuit configurations are also shown with each respective figure. These examples are only guides for configuring the driver. Durel provides a D305A Designer's Kit, which includes a printed circuit evaluation board intended to aid you in developing an EL lamp driver configuration using the D305A that meets your requirements. A section on designing with the D305A is included in this datasheet to serve as a guide to help you select the appropriate external components to complete your D305A EL driver system.

Typical D305A EL Driver Configurations

Handset Color LCD Backlight

Typical Output

Brightness = 19.5 fL (66 cd/m²)
 Lamp Frequency = 500 Hz
 Logic Supply Current = 20 mA
 Power Supply Current = 66 mA
 Vout = 310 Vpp
 Load = 2 in² (12.9 cm²) Durel®3 White EL

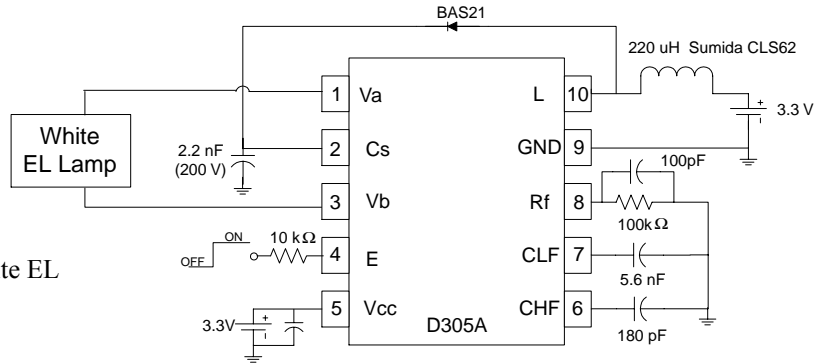

PDA Display

Typical Output

Brightness = 18.5 fL (63 cd/m²)
 Lamp Frequency = 358 Hz
 Logic Supply Current = 18 mA
 Power Supply Current = 87 mA
 Vout = 408 Vpp
 Load = 5 in² (32.2 cm²) Durel®3 Green EL

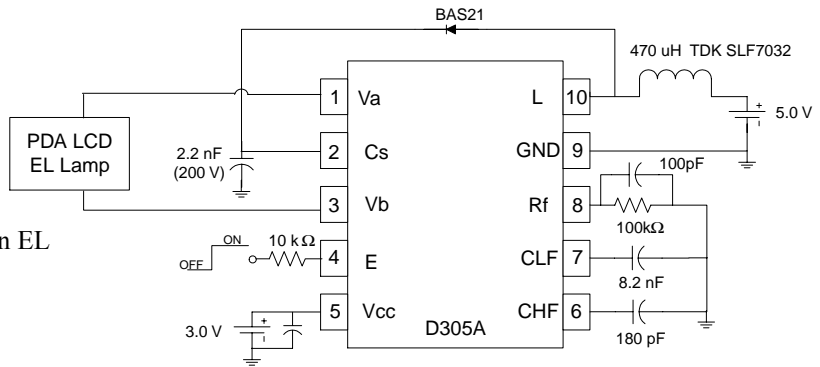

Bright Blue Backlight for LCD

Typical Output

Brightness = 21.5 fL (73 cd/m²)
 Lamp Frequency = 415 Hz
 Logic Supply Current = 19 mA
 Power Supply Current = 68 mA
 Vout = 408 Vpp
 Load = 1 in² (6.5 cm²) Durel®3 Blue EL

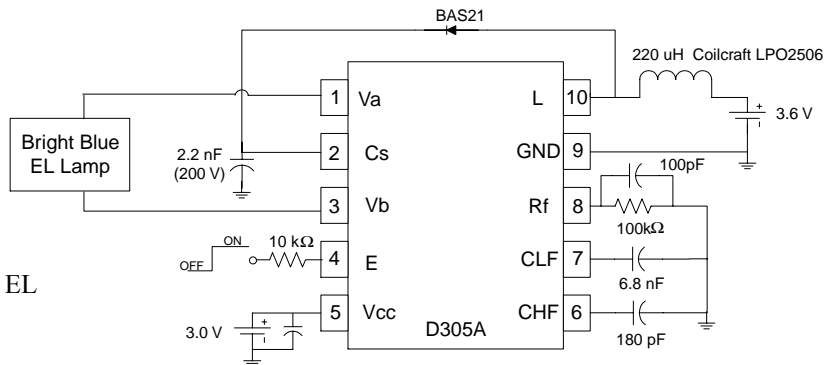

Designing With D305A

There are many variables which can be optimized to achieve the desired performance for specific applications. The luminance of the EL lamp is a function of the output voltage applied to the lamp by the IC, the frequency at which the voltage is applied, the lamp material properties, and the lamp size. Durel offers the following component selection aids to help the designer select the optimum circuit configuration.

I. Lamp Frequency Capacitor (CLF) Selection

Selecting the appropriate value of capacitor (CLF) for the low frequency oscillator will set the output frequency of the D305A EL driver IC. Figure 1 graphically represents the effect of the CLF capacitor value on the oscillator frequency at $V_{bat} = V_{cc} = 3.0V$.

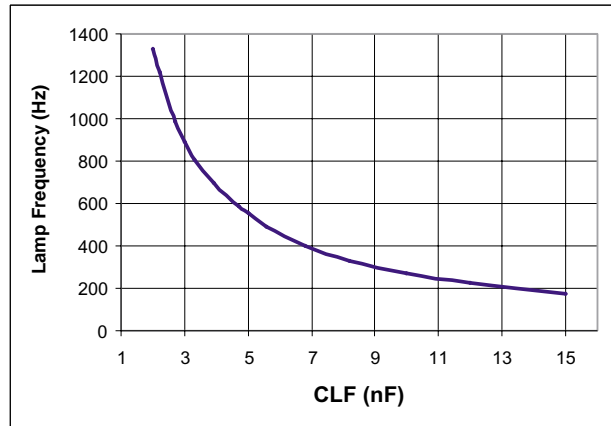

Figure 1: Typical Lamp Frequency vs. CLF Capacitor

II. Inductor Switching Frequency (CHF) Selection

Selecting the appropriate value of capacitor (CHF) for the high frequency oscillator will set the inductor switching frequency of the D305A inverter. Figure 2 graphically represents the effect of the CHF capacitor value on the oscillator frequency at $V_{bat} = V_{cc} = 3.0V$.

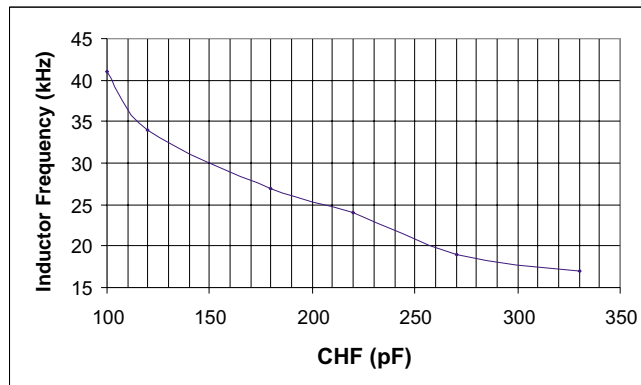

Figure 2: Typical Inductor Frequency vs. CHF Capacitor

III. Inductor (L) Selection

The inductor value has a large impact on the output brightness and current consumption of the driver. Figure 3 shows typical brightness and current draw of a D305A circuit with different inductor values. Please note that the DC resistance (DCR) and current rating of inductors with the same inductance value may vary with manufacturer and inductor type. Thus, inductors made by a different manufacturer may yield different outputs, but the trend of the different curves should be similar. This curve is intended to give the designer a relative scale from which to optimize specific applications. Absolute measurements may vary depending upon the type and brand of other external components selected.

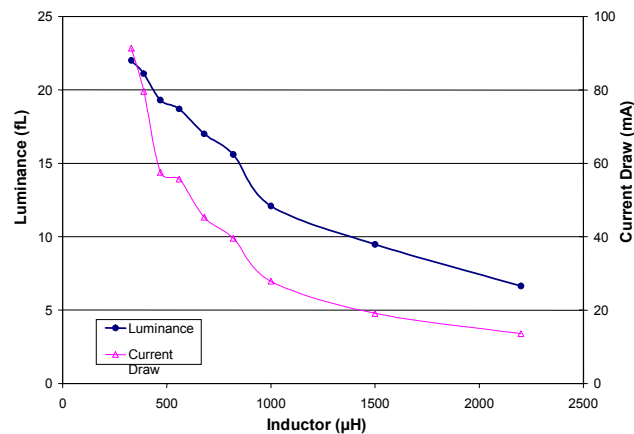

Figure 3: Brightness and current vs. inductor value
Conditions: $V_{cc} = V_{bat} = 3.3V$, 12.9 cm^2 EL Lamp

IV. Wave-Shape Selection

The D305A EL driver IC uses a patented wave-shaping technique for reducing audible noise from an EL lamp. The slope of the discharge section of the output waveform may be adjusted by selecting a proper value for the wave-shape discharge resistor (R_d) in series with the E pin input. The optimal discharge level for an application depends on the lamp size, lamp brightness, and application conditions. To ensure that the D305A is configured optimally, various discharge levels should be evaluated. In many cases, lower discharge levels may result in lower audible noise from the EL lamp. The recommended typical value for R_d is $10 \text{ k}\Omega$.

V. Storage Capacitor (Cs) Selection

The C_s capacitor is used to store the energy transferred from the inductor before discharging the energy to the EL lamp. C_s values can range from 1.5nF to 4.7nF and must have minimum $200V$ rating. In general, the C_s value does not have a large affect on the output of the device. The typical C_s capacitor recommendation is 2.2nF with $200V$ rating.

VI. R_f and C_{Rf} Selection

The combination of R_f and the timing capacitors, CLF and CHF, determines the time constants for the low frequency oscillator and the high frequency oscillator, respectively. To simplify the tuning of the oscillator frequencies to the desired frequency range, a standard value is recommended for $R_f = 100 \text{ k}\Omega$.

The C_{Rf} capacitor is used as a stabilizing capacitor to filter noise on the R_f line. A small 100pF capacitor is typical and sufficient value for C_{Rf} .

VII. Fast Recovery Diode

Energy stored by the coil is eventually forced through the external diode to power the switched H-bridge network. A fast recovery diode, such as BAS21, is recommended for this function for optimum operation.

VIII. Printed Circuit Board Layout

The high frequency operation and very high voltage output of the D305A makes printed circuit board layout important for minimizing electrical noise. Maintain the IC connections to the inductor as short as possible. Connect the GND of the device directly to the GND plane of the PCB. Keep the GND pin of the device and the ground leads of the Cs, CLF, and CHF less than 5mm apart. If using bypass capacitors to minimize ripple on the supply lines, keep the bypass caps as close as possible to the Vbat lead of the inductor and the Vcc pin.

IX. Split Voltage Supply

A split supply voltage is recommended to drive the D305A. To operate the on-chip logic, a regulated voltage supply (Vcc) ranging from 2.0V to 6.5V is applied. To supply the D305A with the necessary power to drive an EL lamp, another supply voltage (Vbat) with higher current capability is applied to the inductor. The voltage range of Vbat is determined by the following conditions: user application, lamp size, inductor selection, and power limitations of the battery.

An example of the split supply configuration is shown below. This example shows a regulated 3.0V applied to the Vcc pin, and a Vbat voltage that may range from 3.6V to 6.2V or regulated at 5.0V. The enable voltage is in the range of 2.0V to 3.0V. This is a typical setup used in PDA applications.

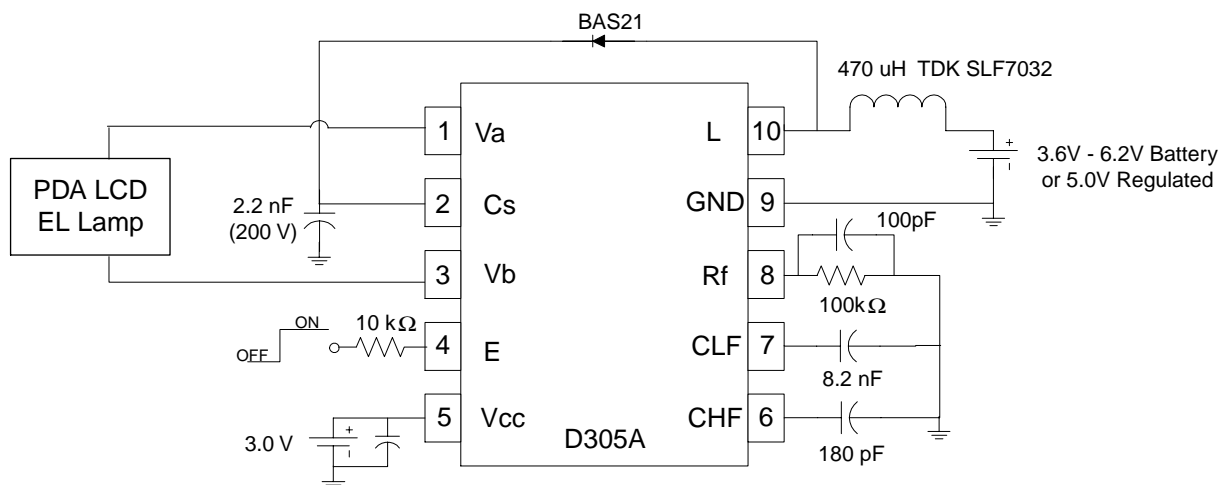

D305A Design Ideas

I. Controlling Output Frequency Using External Clock Signals

External clock signals may be used to control the D305A oscillator frequencies instead of adding external passive components. When clocking signals provide both the inductor charging (HF) and lamp output (LF) oscillator frequencies to drive the D305A, the CLF, CHF, Rf, and CRf components are no longer required. A sample configuration demonstrating this cost-saving option is shown below.

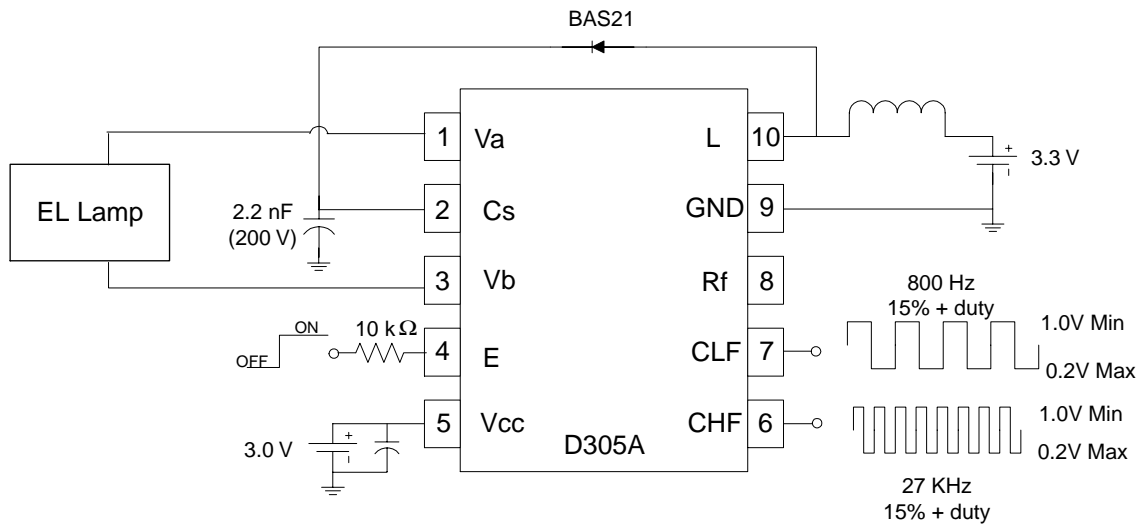

In this configuration, the lamp frequency is controlled by the signal applied to the CLF pin. An internal divider network in the IC divides the frequency of the LF input signal by two. Thus, to get a 400 Hz AC output waveform to drive the EL lamp, an 800 Hz square-wave input signal should be connected to the CLF pin. Input clocking frequencies may range from 400 Hz to 2000 Hz, with 15-20% positive duty cycle for optimum brightness. The amplitude of the clock signal typically ranges from 1.0V to Vcc.

The high frequency oscillator that determines inductor charging frequency is controlled above by a digital AC signal into the CHF pin. The HF clock signal frequency may range from 20KHz - 35KHz, with 15-20% positive duty cycle for optimum lamp intensity. The amplitude of the clock signal typically ranges from 1.0V to Vcc.

II. Controlling EL Brightness through Clock Pulse Width Modulation (Option 1)

Pulse width modulation of the external LF input signal may be used to regulate the brightness of the EL lamp. Figures 4, 5, and 6 below demonstrate examples of the D305A output waveform with pulse width modulation of the LF input signal. As the positive duty cycle of the LF input signal is increased from 15% to 100%, the charging period of the output waveform decreases, and the peak voltage of the output waveform also decreases towards zero output. Therefore, incremental dimming occurs as a result of the wave-shaping changes. This scheme may also be used inversely to regulate lamp brightness over the life of the battery or to compensate for lamp aging. Figure 7 shows a typical dimming curve with this technique. Operation at duty cycles lower than 10% is not recommended. Clocking frequency can range from 400 Hz to 2000 Hz. The maximum amplitude of the clock signal may range from 1.0V to Vcc.

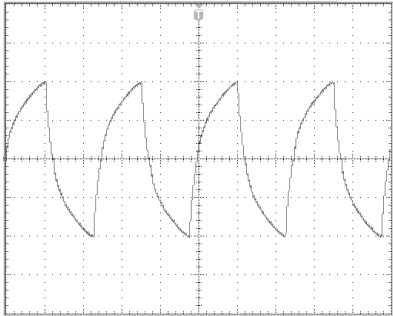
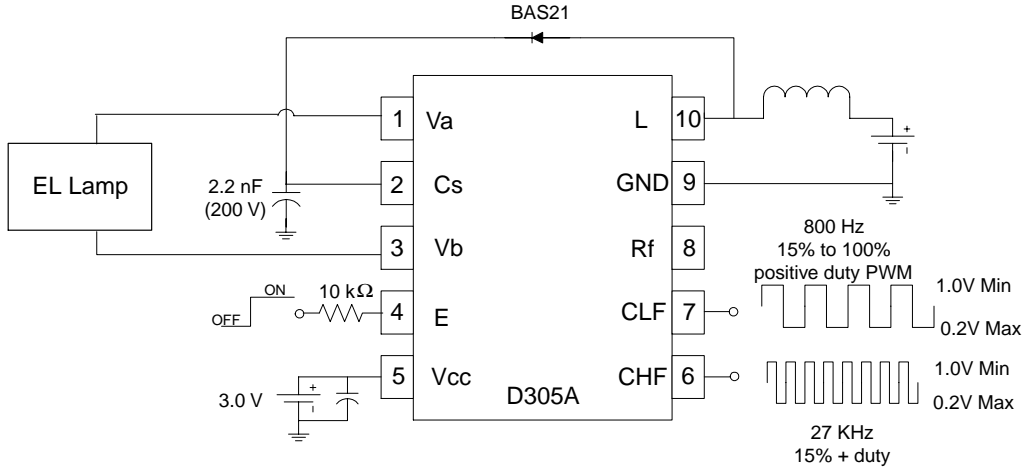

Figure 4: LF Input Duty Cycle = +15%

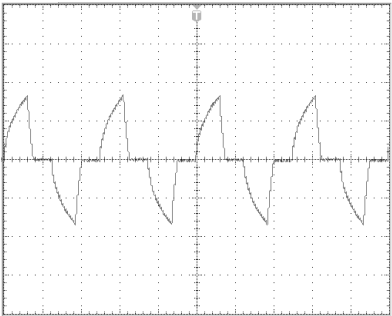

Figure 5: LF Input Duty Cycle = +50%

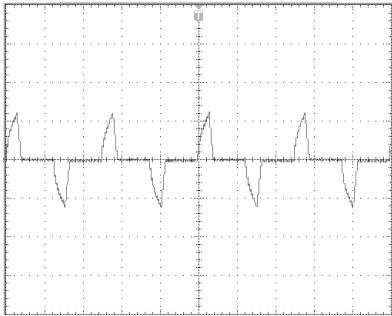

Figure 6: LF Input Duty Cycle = +75%

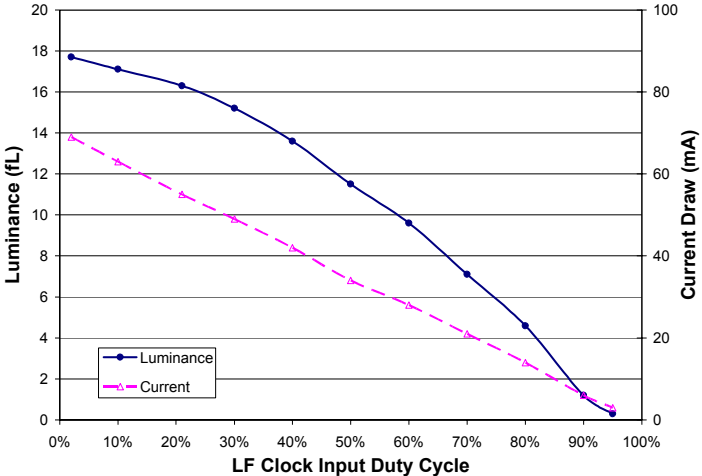

Figure 7: Dimming through LF Clock Input Duty Cycle

III. Controlling EL Brightness through Clock Pulse Width Modulation (Option 2)

Pulse width modulation of the external HF input signal also may be used to regulate the brightness of the EL lamp. As the positive duty cycle of the LF input signal is increased from 15% to 100%, the peak voltage of the output waveform decrease incrementally to zero output as the inductor charging period is affected by the HF duty cycle. Lamp dimming is thus achieved with pulse width modulation of the HF input signal to the D305A. This scheme may also be used inversely to regulate lamp brightness over the life of the battery or to compensate for lamp aging. Figure 8 shows a typical dimming curve with this technique. The recommended HF duty cycle range is from 10% to 95%. Clocking frequency can range from 20 KHz to 35 KHz. The maximum amplitude of the clock signal may range from 1.0V to Vcc.

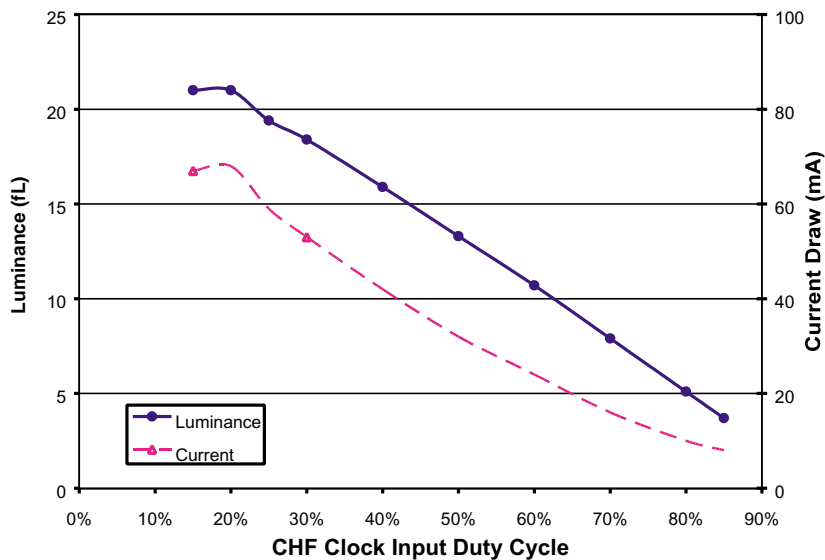
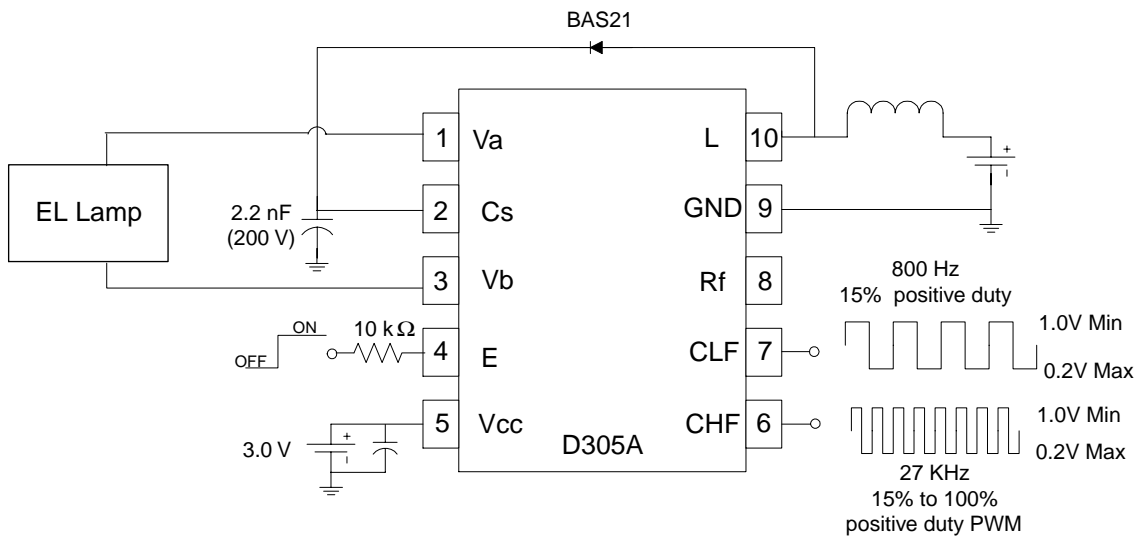
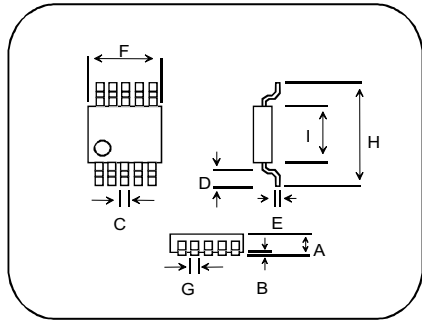

Figure 8: Dimming through HF Clock Input Duty Cycle

Ordering Information:

The D305A IC is available in standard MSOP-10 plastic package per tape and reel. A Durel D305A Designer's Kit (1DDD305AA-K01) provides a vehicle for evaluating and identifying the optimum component values for any particular application using D305A. Durel engineers also provide full support to customers including specialized circuit optimization and application retrofits upon request



Description	MSOP-10					
	Min.		Typical		Max.	
	mm.	in.	mm.	in.	mm.	in.
A	0.92	0.036	1.00	0.039	1.08	0.043
B	0.05	0.002	0.10	0.004	0.15	0.006
C	0.15	0.006	0.23	0.009	0.31	0.012
D	0.40	0.016	0.55	0.022	0.70	0.028
E	0.13	0.005	0.18	0.007	0.23	0.009
F	2.90	0.114	3.00	0.118	3.10	0.122
G	0.35	0.014	0.50	0.020	0.65	0.026
H	4.75	0.187	4.90	0.193	5.05	0.199
I	2.90	0.114	3.00	0.118	3.10	0.122

RECOMMENDED PAD LAYOUT

MSOPs are marked with part number (305A) and 3-digit wafer lot code. Bottom of marking is on the Pin 1 side.

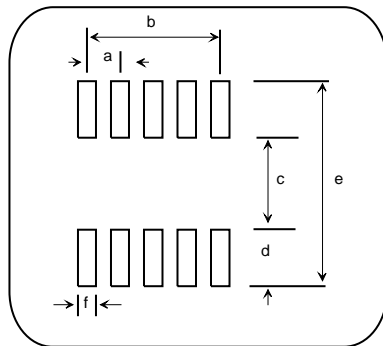

	MSOP-10 PAD LAYOUT					
	Min.		Typical		Max.	
	mm.	in.	mm.	in.	mm.	in.
a			0.5	0.0197		
b			2.0	0.0788		
c	3.3	0.130			3.45	0.136
d	0.89	0.035	0.97	0.038	1.05	0.041
e	5.26	0.207			5.41	0.213
f			0.3	0.012		

MSOPs in Tape and Reel: 1DDD305AA-M04

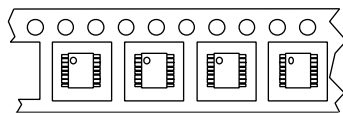

Tape Orientation

Embossed tape on 360 mm diameter reel
Quantity marked on reel label.

ISO 9001 Certified

DUREL Corporation

2225 W. Chandler Blvd.
Chandler, AZ 85224-6155
Tel: (480) 917-6000
FAX: (480) 917-6049
Website: <http://www.durel.com>

The DUREL name and logo are registered trademarks of DUREL CORPORATION. Wave-shaping is a trademark of Durel Corporation.

This information is not intended to and does not create any warranties, express or implied, including any warranty of merchantability or fitness for a particular purpose. The relative merits of materials for a specific application should be determined by your evaluation.

This driver IC is covered by the following U.S. patents: #5,313,141, #5,789,870, #6,297,597 B1. Corresponding foreign patents are issued and pending.