

E-CMOS

EC3597 1.1

3D PS/2 MOUSE CONTROLLER WITH AUTO-REF.

FEATURES

- . Auto-reference function for X-, Y-, Z-axis.
- . 70 KHz RC oscillator
- . 4 types of Z-axis encoders: button, optical 2:1, 4:1 & mechanical 2:1

ORDERING INFORMATION:

Encoder type	70 K Hz (RC)
2:1 Optical	EC3597AR
Button	EC3597BR
4:1 Optical	EC3597CR
2:1 Mechanical	EC3597DR

1. PIN CONFIGURATION

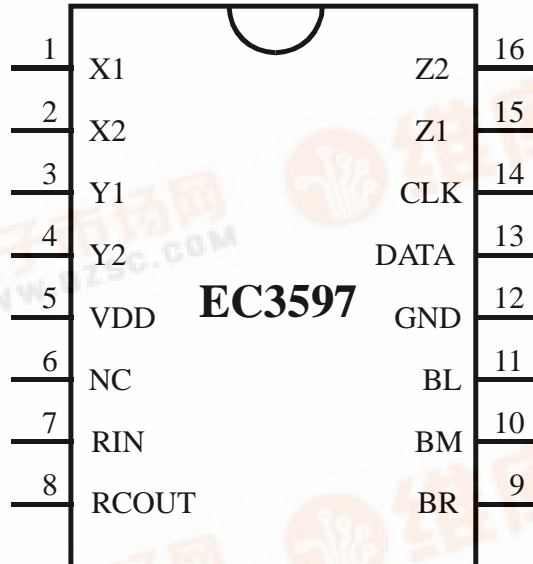

2. PIN DESCRIPTION

PIN No.	PIN NAME	I/O	FUNCTION
1	X1	I	Input from X-axis photo-encoder.
2	X2	I	Input from X-axis photo-encoder.
3	Y1	I	Input from Y-axis photo-encoder.
4	Y2	I	Input from Y-axis photo-encoder.
5	VDD	P	+5V power supply.
6	NC	I	No Connection
7	RIN	I	RC/crystal oscillator input.
8	RCOUT	O	RC/crystal oscillator output.
9	BR	I	Right button input.
10	BM	I	Middle button input.
11	BL	I	Left button input.
12	GND	P	Power ground.
13	DATA	I/O	Bidirectional DATA I/O pin .
14	CLK	I/O	Bidirectional CLK I/O pin.
15	Z1	I	Input from Z-axis encoder.
16	Z2	I	Input from Z-axis encoder.

3. DC ELECTRICAL CHARACTERISTICS

PARAMETER	MIN.	TYP.	MAX.	UNIT
Operating Voltage	4.5	5	5.5	V
Operating Current (no load)			2	mA
BL, BM, BR internal pull-up resistance		50		Kohm
X1, X2, Y1, Y2 internal pull-down resistance		12		Kohm
Z1, Z2 (A/C type) Internal pull-down resistance		12		Kohm
Z1, Z2 (B type) internal pull-up resistance		100		Kohm
Z1, Z2 (D type) internal pull-down resistance		100		Kohm
CLK, DATA internal pull-up resistance		5		Kohm
X1, X2, Y1, Y2, Z1, Z2 input range	0.1		3.2	V
X1, X2, Y1, Y2, Z1, Z2 input amplitude	0.6			V

4. AC ELECTRICAL CHARACTERISTICS

Parameter	Min	Typ	Max	Unit
Operating frequency (R-series)		70		KHz
CLK active time		42.9		μs
CLK inactive time		42.9		μs
BL, BM, BR debounce time	48			ms

5. DATA FORMAT

5.1 Standard 2D PS/2:

BYTE	BIT							
	7	6	5	4	3	2	1	0
1	Yv	Xv	Ys	Xs	1	BM	BR	BL
2	X7	X6	X5	X4	X3	X2	X1	X0
3	Y7	Y6	Y5	Y4	Y3	Y2	Y1	Y0

5.2 Standard 3D PS/2:

BYTE	BIT							
	7	6	5	4	3	2	1	0
1	Yv	Xv	Ys	Xs	1	BM	BR	BL
2	X7	X6	X5	X4	X3	X2	X1	X0
3	Y7	Y6	Y5	Y4	Y3	Y2	Y1	Y0
4	Z7	Z6	Z5	Z4	Z3	Z2	Z1	Z0

6. PS/2 COMMAND LIST

HEX CODE	COMMAND	RESPONSE
FF	Reset	FA, AA, 00
FE	Resend	XX, (XX, XX)
F6	Set Default	FA
F5	Disable	FA
F4	Enable	FA
F3, XX	Set Sampling Rate	FA, FA
F2	Read Device Type	FA, 00
F0	Set Remote Mode	FA
EE	Set Wrap Mode	FA
EC	Reset Wrap Mode	FA
EB	Read Data	FA, XX, XX, XX
EA	Set Stream Mode	FA
E9	Status Request	FA, XX, XX, XX
E8, XX	Set Resolution	FA, FA
E7	Set Scaling 2:1	FA
E6	Reset Scaling	FA

6.1 F3,XX Set Sampling Rate

SECOND BYTE XX	SAMPLING RATE
0A	10/sec.
14	20/sec.
28	40/sec.
3C	60/sec.
50	80/sec.
64	100/sec.
C8	200/sec.

6.2 E9 Status Request

BYTE	BIT	DESCRIPTION
3	0-7	Current Sampling Rate (Bit 0=LSB)

2	0-7	Current Resolution Setting (Bit 0=LSB)
1	7	Reserved
	6	0 = Stream Mode, 1 = Remote Mode
	5	0 = Disabled, 1 = Enabled
	4	0 = Scaling 1:1, 1 = Scaling 2:1
	3	Reserved
	2	1= Left Button Pressed
	1	1= Middle Button Pressed
	0	1 = Right Button Pressed

6.3 E8,XX Set Resolution

SECOND BYTE XX	RESOLUTION (COUNTS PER MM)
00	1
01	2
02	4
03	8

7. 3D MOUSE COMMAND SEQUENCE (PS/2)

7.1

Command	Response
F3	FA
C8	FA
F3	FA
64	FA
F3	FA
50	FA
F2	FA,03

7.2 Whenever the mouse received command 'FF', it will reset to 2D mode.

TYPICAL APPLICATION CIRCUIT (FOR REFERENCE ONLY)

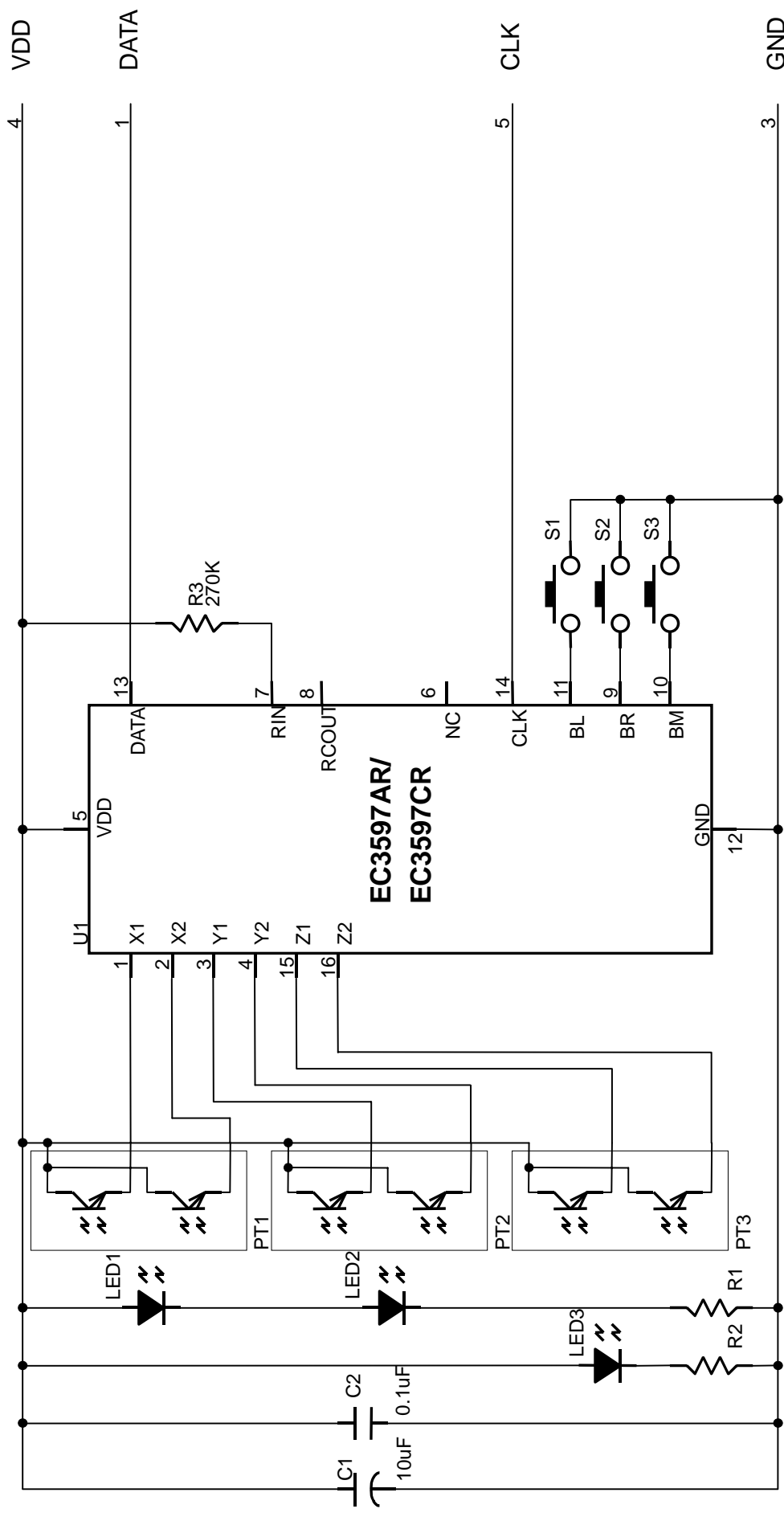

TYPICAL APPLICATION CIRCUIT (FOR REFERENCE ONLY)

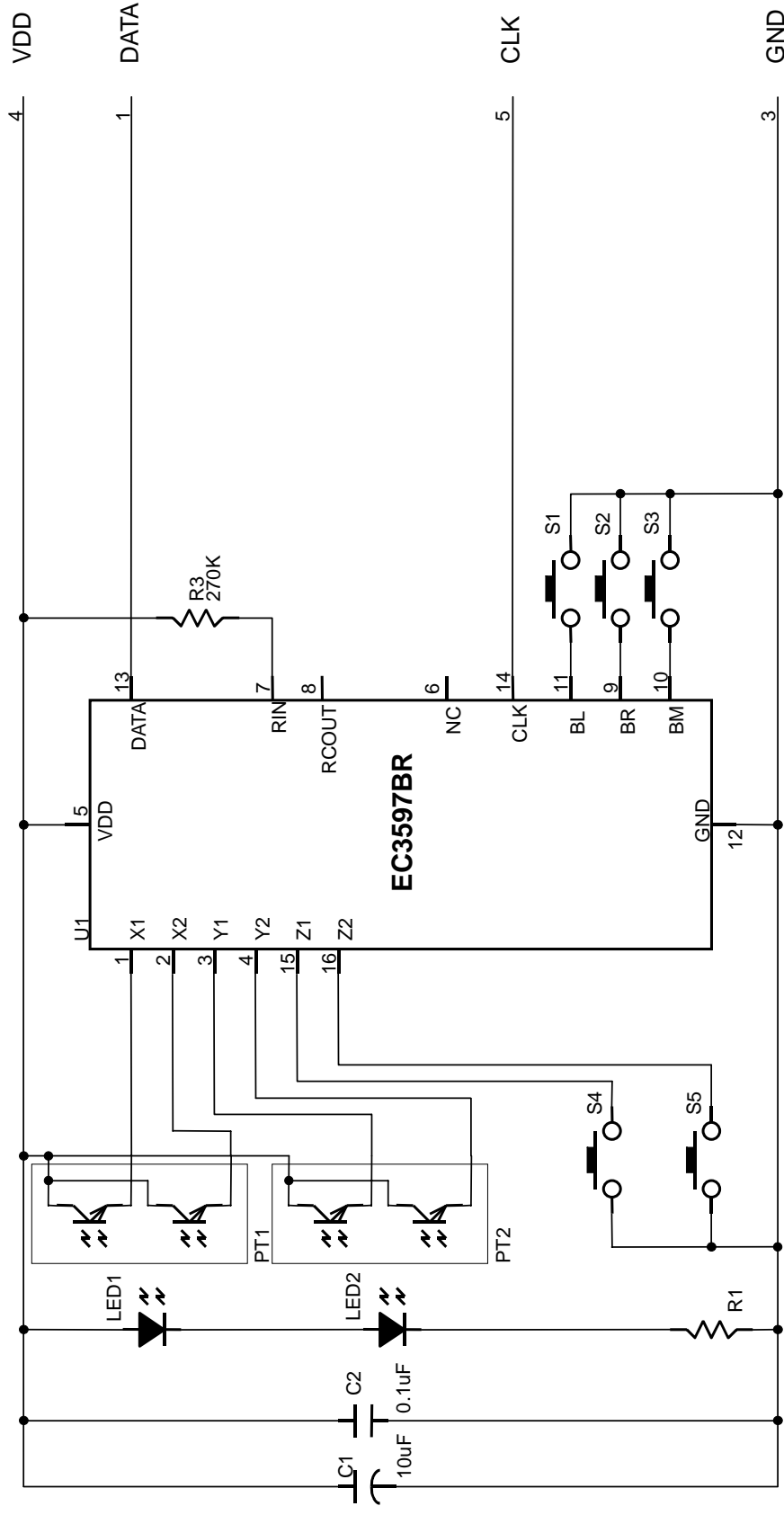

TYPICAL APPLICATION CIRCUIT (FOR REFERENCE ONLY)

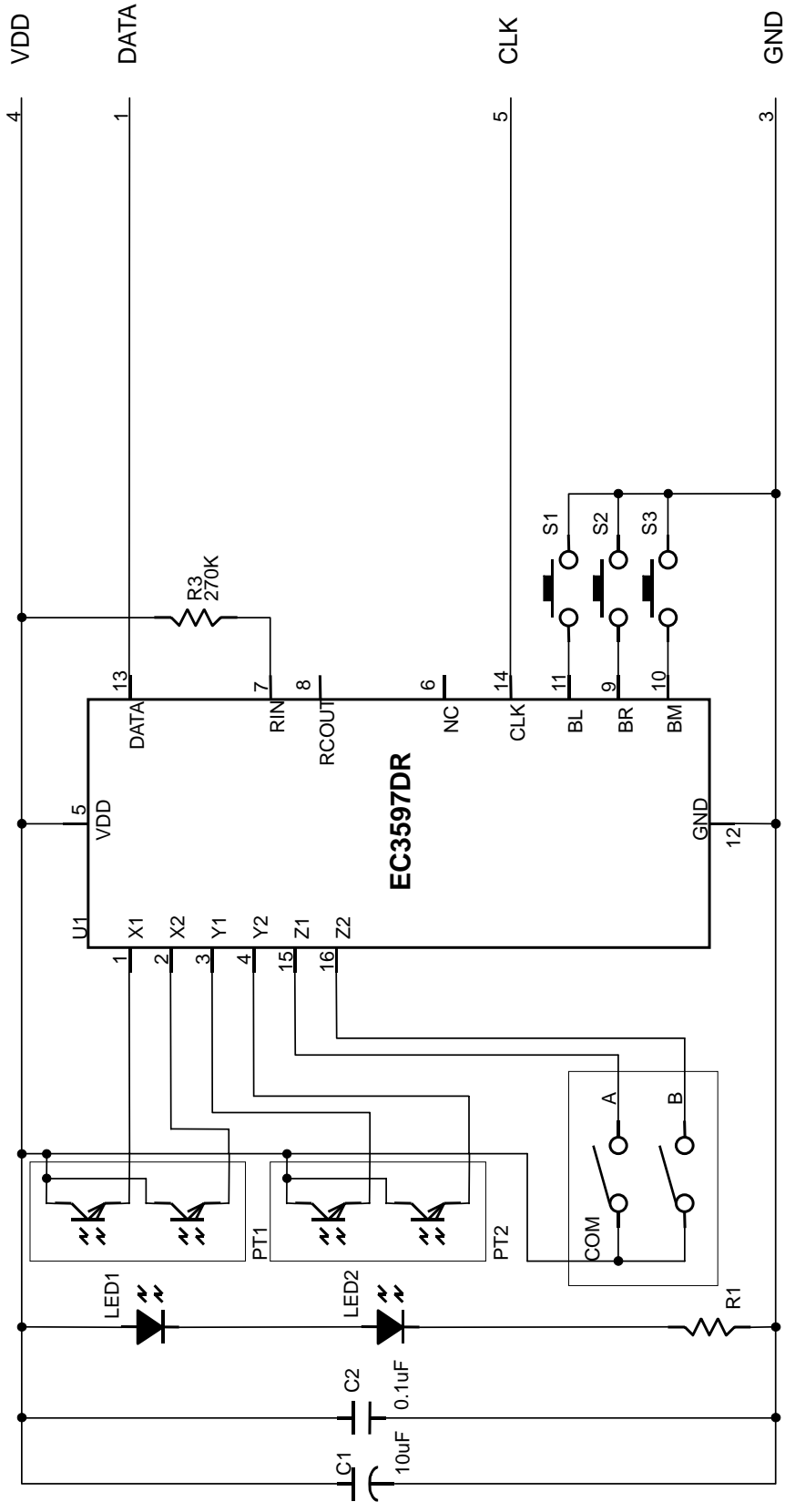

E-CMOS

EC3597 1.1

Typical Application Circuit For HDNS-2000 Optical Input (For Reference Only)

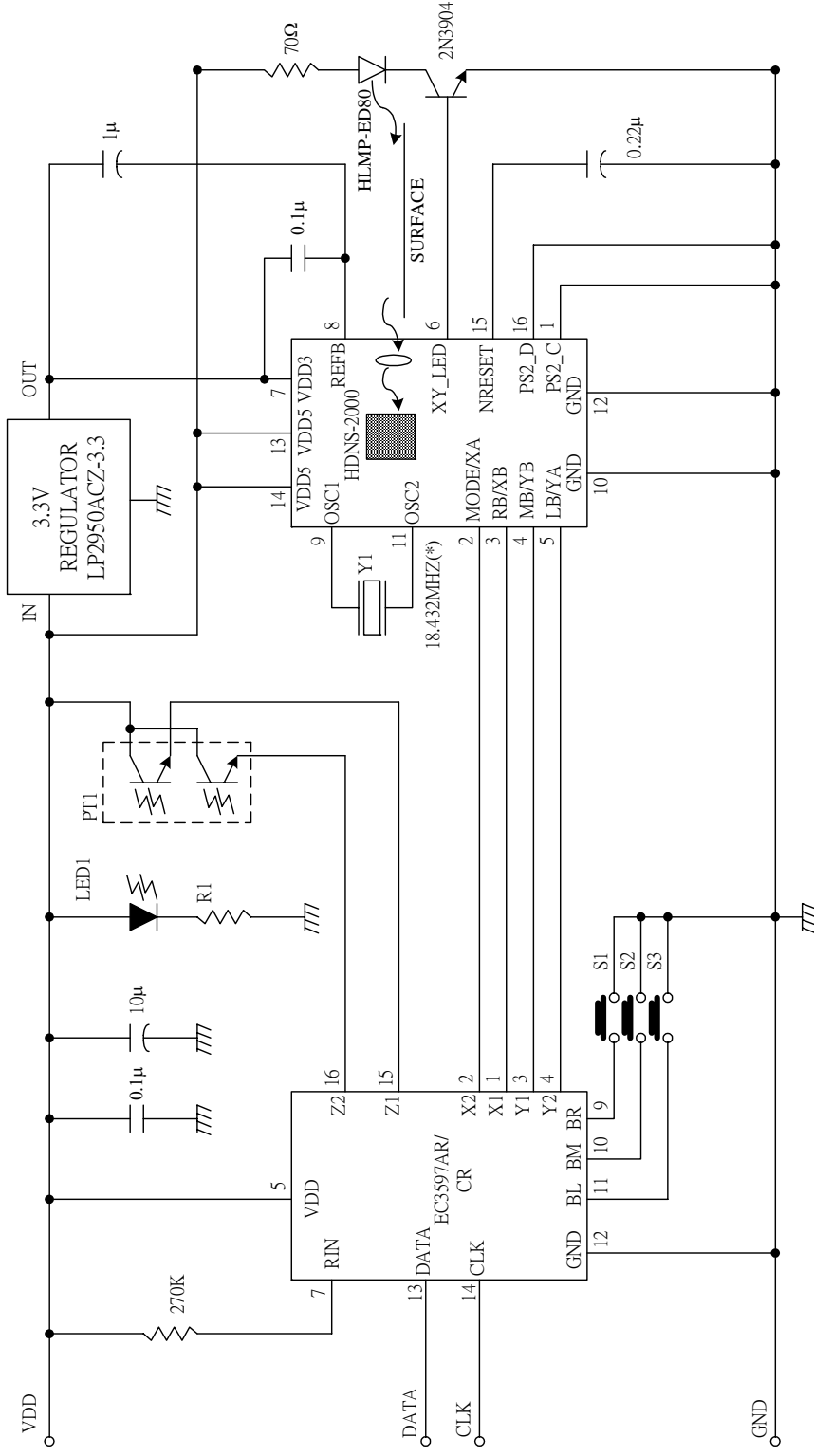

(*)Y1 IS A CERAMIC RESONATOR SUCH AS CSA18.43MXZ040 (FROM MURATA) OR KBR-18.43-MSA(FROM AVX).

Typical Application Circuit For HDNS-2000 Optical Input (For Reference Only)

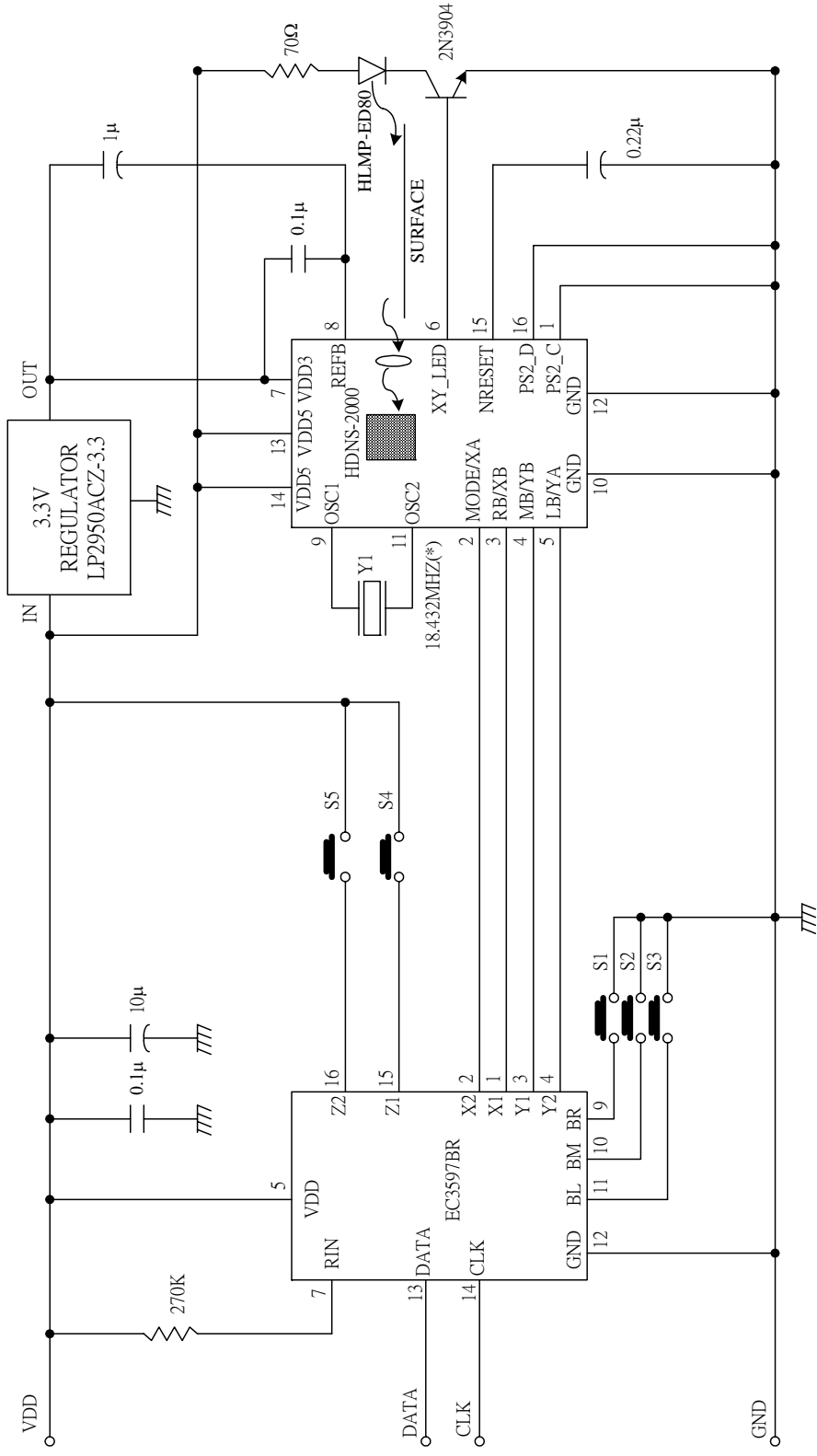

(*Y1 IS A CERAMIC RESONATOR SUCH AS CSA18.43MXZ040 (FROM MURATA) OR KBR-18.43-MSA(FROM AVX).

Typical Application Circuit For HDNS-2000 Optical Input (For Reference Only)

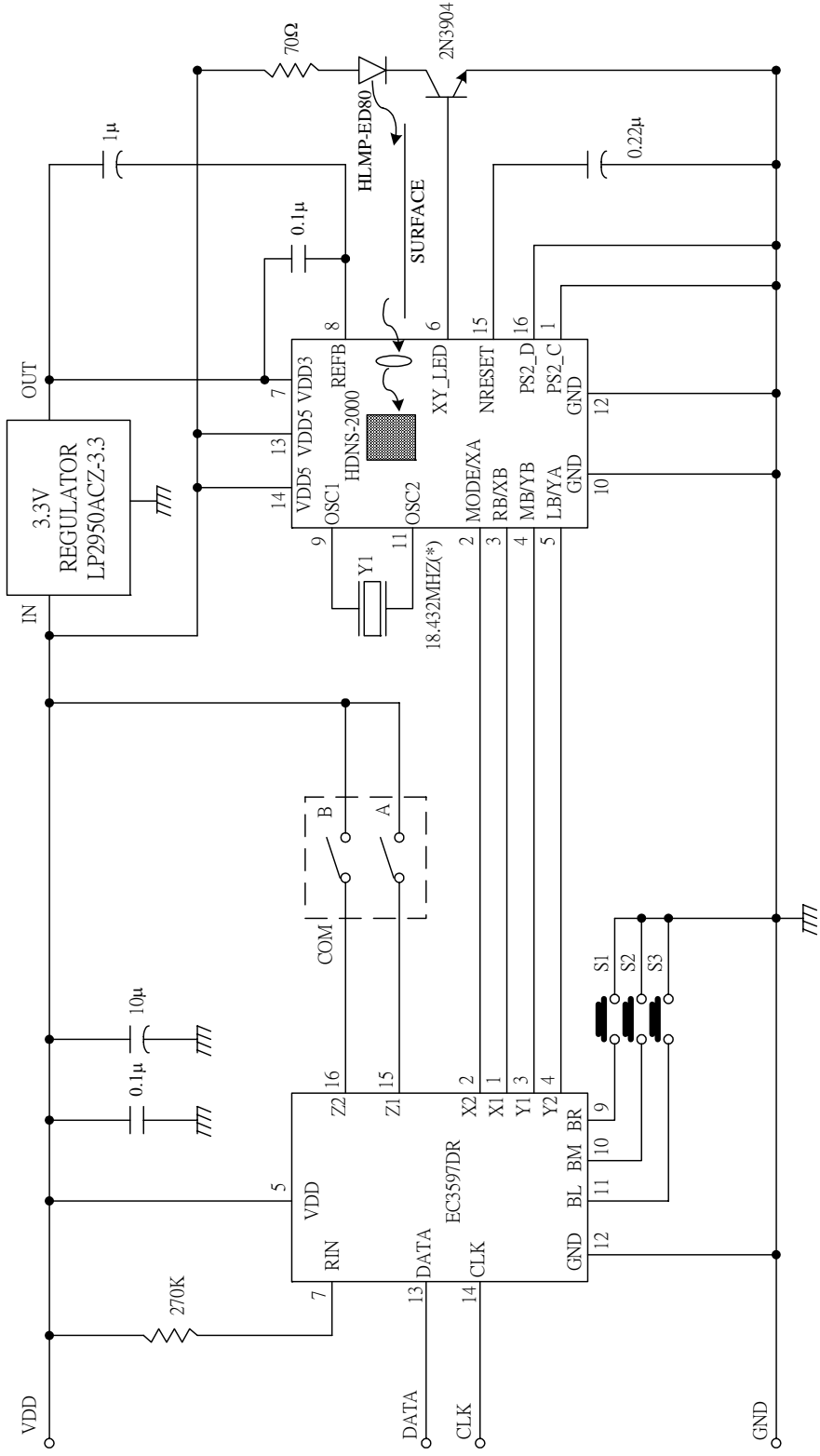

(*Y1 IS A CERAMIC RESONATOR SUCH AS CSA18.43MXZ040 (FROM MURATA) OR KBR-18.43-MSA (FROM AVX).