

[查询EDSCDT370供应商](#)

[捷多邦，专业PCB打样工厂，24小时加急出货](#)



TMS370 Microcontroller Family

Extract

Data Book

1997

8-Bit Microcontroller Family





General Information	1
Quality and Reliability	2
Electrostatic Discharge Guidelines	3
Mechanical Data	4

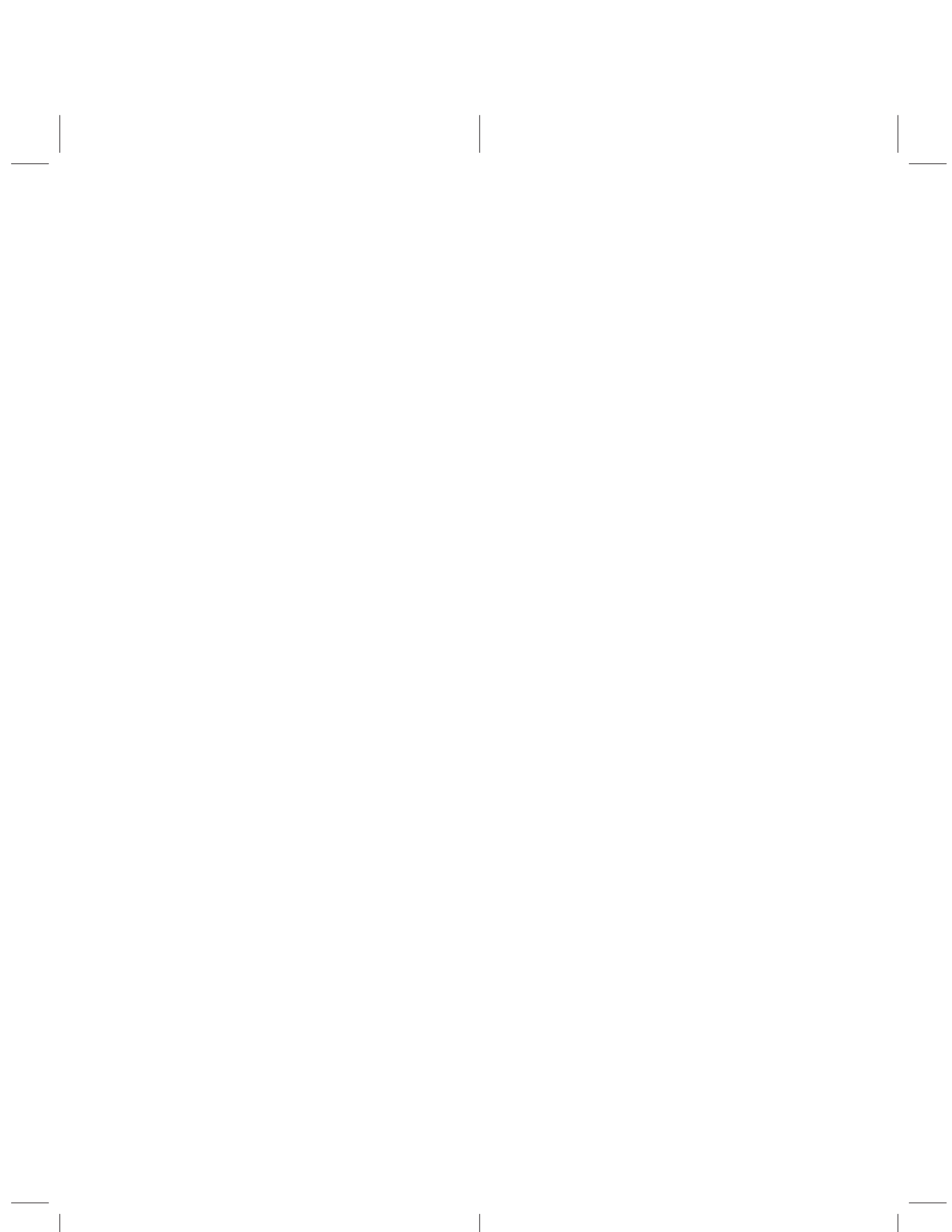

TMS370 Microcontroller Family Data Book

Extract

SPND005
March 1997



IMPORTANT NOTICE

Texas Instruments (TI) reserves the right to make changes to its products or to discontinue any semiconductor product or service without notice, and advises its customers to obtain the latest version of relevant information to verify, before placing orders, that the information being relied on is current.

TI warrants performance of its semiconductor products and related software to the specifications applicable at the time of sale in accordance with TI's standard warranty. Testing and other quality control techniques are utilized to the extent TI deems necessary to support this warranty. Specific testing of all parameters of each device is not necessarily performed, except those mandated by government requirements.

Certain applications using semiconductor products may involve potential risks of death, personal injury, or severe property or environmental damage ("Critical Applications").

TI SEMICONDUCTOR PRODUCTS ARE NOT DESIGNED, INTENDED, AUTHORIZED, OR WARRANTED TO BE SUITABLE FOR USE IN LIFE-SUPPORT APPLICATIONS, DEVICES OR SYSTEMS OR OTHER CRITICAL APPLICATIONS.

Inclusion of TI products in such applications is understood to be fully at the risk of the customer. Use of TI products in such applications requires the written approval of an appropriate TI officer. Questions concerning potential risk applications should be directed to TI through a local SC sales office.

In order to minimize risks associated with the customer's applications, adequate design and operating safeguards should be provided by the customer to minimize inherent or procedural hazards.

TI assumes no liability for applications assistance, customer product design, software performance, or infringement of patents or services described herein. Nor does TI warrant or represent that any license, either express or implied, is granted under any patent right, copyright, mask work right, or other intellectual property right of TI covering or relating to any combination, machine, or process in which such semiconductor products or services might be or are used.

INTRODUCTION

The TMS370 Microcontroller Family Data Book from Texas Instruments includes complete detailed specifications on the TMS370 8-Bit Microcontroller Family product line to include the following subfamilies TMS370Cx0x, TMS370Cx1x, TMS370Cx2x, TMS370Cx32, TMS370Cx36, TMS370Cx4x, TMS370Cx5x, TMS370Cx6x, TMS370Cx7x, TMS370Cx8x, TMS370Cx9x, TMS370CxAx, TMS370CxBx, and TMS370CxCx.

The objective of this manual is to provide the user with complete information on all the subfamilies contained within the TMS370 Family, enabling selection of a particular device to suit the user's needs and application much easier.

The data book is divided into the following sections, each of which is described briefly below:

Section 1. General Information – Introduces the TMS370 Family of devices, discusses the key features and major components of the device family, provides a functional-block-diagram generalization, and contains an ordering guide showing the device-numbering convention for all 14 subfamilies. This section also provides a selection reference guide; a listing of the development system support tools; defines: acronyms, key terms and signal names; operating conditions and characteristics; and timing conventions.

Section 2. Quality and Reliability – Details the selected processes, standards and philosophies that Texas Instruments uses to ensure the production of high quality products.

Section 3. Guidelines for Handling Electrostatic-Discharge-Sensitive Devices and Assemblies – Because the devices included in the TMS370 8-Bit Microcontroller Family are categorized as Class 2 ESD-sensitive, this section includes the guidelines for the handling of ESD-sensitive devices.

Section 4. Mechanical Data – Shows the detailed mechanical drawing packages and the associated specifications for each package type utilized in the TMS370 family. This section also provides a cross-reference table to identify the mechanical package type(s) to a specific device family.

For ordering information or further assistance, please contact your nearest Texas Instruments sales office or distributor as listed on the back page of this book.

PRODUCT STAGE STATEMENTS

Product stage statements are used on Texas Instruments data sheets to indicate the development stage(s) of the product(s) specified in the data sheets.

If all products specified in a data sheet are at the same development stage, the appropriate statement from the following list is placed in the lower left corner of the first page of the data sheet.

PRODUCTION DATA information is current as of publication date. Products conform to specifications per the terms of Texas Instruments standard warranty. Production processing does not necessarily include testing of all parameters.

ADVANCE INFORMATION concerns new products in the sampling or preproduction phase of development. Characteristic data and other specifications are subject to change without notice.

PRODUCT PREVIEW information concerns products in the formative or design phase of development. Characteristic data and other specifications are design goals. Texas Instruments reserves the right to change or discontinue these products without notice.

If not all products specified in a data sheet are at the PRODUCTION DATA stage, then the first statement below is placed in the lower left corner of the first page of the data sheet. Subsequent pages of the data sheet containing PRODUCT PREVIEW information or ADVANCE INFORMATION are then marked in the lower left-hand corner with the appropriate statement given below:

UNLESS OTHERWISE NOTED this document contains PRODUCTION DATA information current as of publication date. Products conform to specifications per the terms of Texas Instruments standard warranty. Production processing does not necessarily include testing of all parameters.

ADVANCE INFORMATION concerns new products in the sampling or preproduction phase of development. Characteristic data and other specifications are subject to change without notice.

PRODUCT PREVIEW information concerns products in the formative or design phase of development. Characteristic data and other specifications are design goals. Texas Instruments reserves the right to change or discontinue these products without notice.

General Information	1
Quality and Reliability	2
Electrostatic Discharge Guidelines	3
Mechanical Data	4

Contents

	Page
Introduction to the TMS370 Family of Devices	1–3
Overview	1–4
Typical Applications	1–4
Device Categories	1–5
Key Features	1–6
TMS370 Major Components Architecture	1–7
Functional-Block-Diagram Generalization	1–11
Device-Numbering Conventions	1–13
Available Development System Support Tools	1–14
Selection Reference Guide	1–15
Development Systems Support Tools	1–15
Third-Party Support	1–21
Operating Conditions and Characteristics	1–22
Timing Conventions	1–23
Related Documentation From Texas Instruments	1–27
For Further Assistance	1–28
Glossary/Symbols, Terms, and Definitions	1–29

introduction to the TMS370 family of devices

This section discusses the key features and major components of the TMS370 8-Bit Microcontroller subfamilies ('x0x, 'x1x, 'x2x, 'x32, 'x36, 'x4x, ..., 'xCx) and includes a functional-block-diagram generalization that depicts all available modules, noting that no one device contains all the available modules. The section concludes with the device-numbering convention and a list of other Texas Instruments related documents.

This section covers the following topics:

- Overview
- Typical Applications
- Device Categories
- Key Features
- TMS370 Major Components Architecture
 - CPU
 - Register File (RF)
 - RAM
 - Data EEPROM
 - Program Memory (ROM/EPROM)
 - Input/Output Ports
 - Timer 1
 - Timer 2n (A and B)
 - Watchdog Timer
 - Programmable Acquisition and Control Timer (PACT)
 - Serial Communications Interface (SCI1 or SCI2)
 - Serial Peripheral Interface (SPI)
 - Analog-to-Digital Converter (ADC1, ADC2 or ADC3) Modules
- Functional-Block-Diagram Generalization
- Device-Numbering Conventions
- Available Development-System-Support Tools
- Section Reference Guide
- Development-System-Support Tools
- Operating Conditions and Characteristics
- Timing Conventions
- Related Documentation from Texas Instruments
- For Further Assistance
- Glossary/Symbols, Terms, and Definitions

OVERVIEW

overview

The TMS370 family consists of very large scaled integration (VLSI), 8-bit, complementary metal oxide semiconductor (CMOS) microcontrollers with on-chip EEPROM storage and peripheral-support functions. These devices offer superior performance in complex, real-time control applications in demanding environments and are available in mask-programmable ROM and EPROM.

In a continual effort to improve its products, Texas Instruments has added new, more robust features to the TMS370 family of devices that are designed to enhance performance and enable new application technologies. These added features include new watchdog modes and low-power modes for mask-ROM devices. All family members are software compatible, so that many existing applications can be run on the improved devices without modification of software. (Refer to the associated data sheets for more information on compatibility.)

In expanding its powerful TMS370 family of microcontrollers, TI™ offers many new configurable devices for specific applications. As microcontrollers have evolved, TI has added multiple peripheral functions to chips that originally had only a central processing unit (CPU), memory, and I/O blocks. Now, with the high-performance, software-compatible TMS370 microcontrollers, over 130 standard products are available. Also, up to 27 function modules can be used to configure a new device quickly, easily, and cost-effectively for any applications.

The TMS370 family is supported fully by TI development tools that facilitate simplified software development for prompt market introduction of new products. These tools include an assembler, an optimizing C compiler, a linker, a C source debugger, a design kit, a starter kit, and a third-party microcontroller programmer from BP Microsystems. All of these tools work together by using an IBM™-compatible personal computer (PC) as the host and the central control element. This allows the user to select the host computer and text management as well as editing tools according to system requirements.

Additionally, the TMS370 in-circuit emulator [XDS™—extended development support, and CDT370 compact development tool (CDT™)] allows the user to immediately begin designing, testing, and debugging the system upon specification. The reason for this is straightforward: the emulator itself is modular and configurable, thereby eliminating the need to produce a new emulator for each TMS370 configuration.

typical applications

The TMS370 family of devices is the ideal choice for the applications shown in Table 1 because the newly added features (like the addition of multiple peripheral functions per device) have expanded the TMS370 family of microcontrollers, enhanced its performance, and opened up new application technologies.

Table 1. Typical Applications for TMS370 Family of Microcontroller Devices

APPLICATION AREA	APPLICATIONS	
Automotive	Climate control systems Cruise control Entertainment systems Instrumentation	Navigational systems Engine control Antilock braking
Computer	Keyboards Peripheral interface control	Disk controllers Terminals
Industrial	Motor control Temperature controllers Process control	Meter control Medical instrumentation Security systems
Telecommunications	Modems Intelligent phones Intelligent line card control	Telecopiers Debit cards

TI, XDS, and CDT are trademarks of Texas Instruments Incorporated.
IBM is a trademark of International Business Machines Corp.

device categories

The TMS370 category of devices is divided into 14 subfamilies (see Table 2). All the subfamilies are supported by a full complement of development support tools, which are listed in Table 5.

Table 2. TMS370 Family Categories and Their Corresponding Devices

FAMILY	DEVICES INCLUDED				
TMS370Cx0x	TMS370C002A	TMS370C302A	TMS370C702†	SE370C702†	
TMS370Cx1x	TMS370C010A TMS370C712A	TMS370C012A TMS370C712B	TMS370C310A SE370C712A†	TMS370C311A SE370C712B†	TMS370C312A
TMS370Cx2x	TMS370C020A SE370C722†	TMS370C022A	TMS370C320A	TMS370C322A	TMS370C722
TMS370Cx32	TMS370C032A	TMS370C732A	TMS370C332A	SE370C732A†	
TMS370Cx36	TMS370C036A	TMS370C736A	SE370C736A†		
TMS370Cx4x	TMS370C040A SE370C742A†	TMS370C042A	TMS370C340A	TMS370C342A	TMS370C742A
TMS370Cx5x	TMS370C050A TMS370C150A TMS370C352A TMS370C456A SE370C756A†	TMS370C052A TMS370C156A TMS370C353A TMS370C756A SE370C758A†	TMS370C056A TMS370C250A TMS370C356A TMS370C758A SE370C758B†	TMS370C058A TMS370C256A TMS370C358A TMS370C758B SE370C759A†	TMS370C059A TMS370C350A TMS370C452A TMS370C759A
TMS370Cx6x	TMS370C067A SE370C768A†	TMS370C068A SE370C769A†	TMS370C069A	TMS370C768A	TMS370C769A
TMS370Cx7x	TMS370C077A	TMS370C777A	SE370C777A†		
TMS370Cx8x	TMS370C080	TMS370C380A	TMS370C686A	SE370C686A†	
TMS370Cx9x	TMS370C090A	TMS370C792	SE370C792†		
TMS370CxAx	TMS370C3A7A				
TMS370CxBx	TMS370C0B6A				
TMS370CxCx	TMS370C3C0A	TMS370C6C2A	SE370C6C2A†		

† These system evaluators are used only in a prototype environment. Their reliability has not been characterized.

KEY FEATURES

key features

The TMS370 family is based on a register-to-register architecture that allows access to a register file (up to 256 bytes) in a single bus cycle. On-chip memory includes program memory (mask ROM or EPROM), static RAM, standby RAM, and data EEPROM.

The versatile on-chip peripheral functions include an analog-to-digital converter (ADC1, ADC2, or ADC3), a serial communications interface (SCI1 or SCI2), a serial peripheral interface (SPI), three different timer modules (T1, T2A, and T2B), and up to 55 digital input/output (I/O) pins. The number and type of peripheral functions (modules) is dependent on the TMS370 subfamily.

The following are key features of the TMS370 device family (not all features are available for all devices):

- Compatibility for supporting software migration between current and future microcontrollers
- CMOS EPROM technology for providing reprogrammable EPROM and one-time programmable (OTP) program memory for prototypes and for small-volume or quick-turn production
- CMOS EEPROM technology for providing EEPROM programming with a single 5-V supply
- ADC technology for converting analog signals to digital values
- Static RAM/register file registers that offer numerous memory options
- Standby RAM that offers data protection in power-off condition
- Programmable (asynchronous and isosynchronous[†]) built-in serial communications interface for control of timing, data format, and protocol
- Serial peripheral interface for providing single-mode synchronous data transmission from the CPUs to any external peripheral devices
- Flexible operating features:
 - Power-reduction-standby and halt modes
 - Temperature options:
 - 0°C to 70°C operating temperature (L)
 - 40°C to 85°C operating temperature (A)
 - 40°C to 105°C operating temperature (T)
 - Input clock frequency options:
 - Divide-by-4 (0.5 MHz to 5 MHz SYSCLK) standard oscillator
 - Divide-by-1 (2 MHz to 5 MHz SYSCLK) phase-locked loop (PLL)
 - Operating voltage range: 5 V +10%
- Flexible interrupt handling for design flexibility:
 - Two programmable interrupt levels
 - Programmable rising-edge or falling-edge detect
- System integrity features that increase flexibility during the software development phase:
 - Oscillator fault detection
 - Privileged mode lockout
 - Watchdog timer
 - Memory security (for ROM)

[†] Isosynchronous = isochronous

key features (continued)

- Memory-mapped ports for easy addressing
- An optimizing C compiler that translates ANSI C programs into TMS370 assembly language source
- A high-level language debugger that lets the user refine and correct code
- A modular library for quickly changing the device configurations
- 18 addressing modes that use eight formats, including:
 - Implied
 - Register-to-register arithmetic
 - Indirect addressing
 - Indexed and indirect branches and calls
 - PC relative
- 250-mA typical latch-up immunity at 25°C
- Electrostatic discharge (ESD) protection that exceeds 2,000 V per MIL-STD-883C method 3015, making the TMS370 families Class 2 ESD-sensitive devices

TMS370 major components architecture

In addition to the features listed in the key features section, the TMS370 family members have the following architectural features. Not all features (key or architectural) are applicable to all devices. The selection reference guide (see Table 4) summarizes the following features and identifies the applicable devices associated with those features.

CPU

The TMS370 8-bit CPU has a status register, program-counter register, and stack pointer. The CPU uses the register file as working registers that are accessed on the internal bus in one bus cycle. The 8-bit internal bus also allows access to memory and to the peripheral interfaces. TMS370Cx5x and TMS370Cx6x devices all allow external memory expansion through ports A, B, C, and D.

register file (RF)

The register file is located at the beginning of the TMS370 memory map. Register-access instructions in the TMS370 instruction set allow access to any of the first 256 registers (if available) in one bus cycle. This segment of the memory map is used as general-purpose RAM and as the stack.

RAM

RAM modules, other than those contained in the register file, are mapped after the register file. The TMS370 accesses this RAM in two cycles.

data EEPROM

With the exception of the TMS370CxAx and TMS370CxCx device groups, certain devices in the TMS370 family have EEPROM. The data EEPROM modules provide in-circuit programmability and data retention in power-off mode. The modules contain 256 or 512 bytes of EEPROM. This memory is useful for storing constants and infrequently changed variables that are required by the application program. The EEPROM can be programmed and erased by using available EEPROM programmers or by the TMS370 device under program control.

TMS370 MAJOR COMPONENTS ARCHITECTURE

program memory (ROM/EPROM)

The program memory provides alternatives to meet the needs of different applications. The program memory modules presently contain 2K, 4K, 8K, 16K, 24K, 32K, or 48K bytes of memory. The program memory in TMS370C6xx, SE370C6xx, TMS370C7xx, and SE370C7xx devices is EPROM. EPROM devices in a windowed ceramic package can be programmed, erased, and reprogrammed for prototyping. EPROM devices in a non-windowed plastic package are one-time programmable (OTP) devices that are used for small production runs. In the TMS370C0xx, TMS370C3xx, and TMS370C4xx devices, the program memory is mask-ROM that is programmed at the factory. ROM devices are appropriate for large-volume production.

input/output ports

The TMS370 family of devices has a varying number of I/O ports that have various port widths. Table 3 lists the available I/O port widths, by the number of bits, for each of the TMS370 subfamilies.

Table 3. Bits Per Port for TMS370 Devices

SUBFAMILIES†	BITS FOR PORTS A–H					
	A	B	C	D	G	H
'x0x, 'x1x	8			5		
'x2x	8	8	1	5		
'x32	8			4		
'x36	8			5		
'x4x	8	3		5		
'x5x – (64 pins)	8‡	8‡	8‡	6‡		
'x5x – (68 pins)	8‡	8‡	8‡	8‡		
'x6x	8‡	8‡	8‡	5‡		
'x7x – (64 pins)	8	8	8	6	6	
'x7x – (68 pins)	8	8	8	8	6	
'x8x – (40 pins)	8	8	6	5		
'x8x – (44 pins)	8	8	8	5		
'x9x	8			5		
'xAx	8	8	1	5		
'xBx – (64 pins)	8	8	8	6	8	1
'xBx – (68 pins)	8	8	8	8	8	1
'xCx	8			4		

† For all subfamilies, the ports for these microcontrollers can be programmed, bit by bit, to function as either digital input or digital output.

‡ These ports can be configured by the software as the data, control, and address buses for external memory. Any bits not needed for external memory can be programmed to be either digital input or digital output.

timer 1

Timer 1 is a 16-bit timer that can be configured in the following ways:

- A programmable 8-bit prescaler (provides a 24-bit real-time timer) that determines the independent clock sources for the general-purpose timer and the watchdog (WD) timer
- A 16-bit event timer to keep a cumulative total of the transitions
- A 16-bit pulse accumulator to measure the pulse-input width
- A 16-bit input-capture function that latches the counter value on the occurrence of an external input
- Two 16-bit compare registers that trigger when the counter matches the contents of a compare register
- A self-contained pulse-width modulated (PWM) output control function

timer 1 (continued)

The results of these operations can generate an interrupt to the CPU, set flag bits, reset the timer counter, toggle an I/O line, or generate PWM outputs. Timer 1 can provide up to 200 ns of resolution with a 5-MHz system clock (SYSCLK).

timer 2n (A and B)

Timer 2A and 2B are 16-bit timers that can be configured in the following ways:

- Four independent clock sources for the general-purpose timer
- A 16-bit event timer, to keep a cumulative total of the transitions
- A 16-bit pulse accumulator, to measure the pulse-input width
- Two 16-bit input-capture devices that change a counter value on the occurrence of an external input
- Two 16-bit compare registers that trigger when a counter matches the contents of a compare register
- A self-contained PWM output controller

The results of the timer 2A and 2B operations can generate an interrupt to the CPU, set flag bits, reset the timer counter, toggle an I/O line, or generate PWM outputs. Timers 2A and 2B can provide up to 200 ns of resolution with a 5-MHz system clock (SYSCLK).

watchdog timer

The watchdog (WD) timer helps ensure system integrity. The WD timer can be programmed to generate a hardware reset upon a time-out condition. The WD function provides a hardware monitor over the software to help avoid losing a program. If not needed as a WD, this timer can be used as a general-purpose timer.

programmable acquisition and control timer (PACT)

The PACT module in the 'x32 and 'x36 subfamilies is a programmable timing module that uses some of the on-chip RAM to store its commands and the timer values. Only the TMS370Cx36 device offers the 256-byte standby RAM that protects stored data against power failures. The PACT module offers the following:

- Input capture on up to six pins, four of which may have a programmable prescaler
- One input-capture pin that can drive an 8-bit event counter
- Up to eight timer-driven outputs
- Timer capability of up to 20 bits
- Interaction between event counter and timer activity
- 18 independent interrupt vectors to allow better servicing of events
- Watchdog with selectable time-out period
- Mini-SCI (serial communications interface) that works as a full duplex UART (universal asynchronous receiver transmitter)

Once set up, the PACT requires no CPU overhead except to service interrupts.

TMS370 MAJOR COMPONENTS ARCHITECTURE

serial communications interface (SCI1 or SCI2)

The term SCI is used frequently to refer to SCI1 and SCI2. The SCI1 and SCI2 modules are built-in serial interfaces. The SCI1 has a 3-pin configuration and SCI2 has a 2-pin configuration. Both offer the following features:

- Programmable to be asynchronous (up to 156 Kbps)
- Full duplex, double-buffered receive (Rx) and transmit (Tx)
- Programmable format with error-checking capabilities

The following feature is available only on the SCI1 module:

- Programmable to be isosynchronous (up to 2.5 Mbps)

The SCI1 and SCI2 modules program and control all timing, data format, and protocol factors. The CPU takes part in the serial communications only:

- To write data transmitted to the registers in the SCI
- To read received data from the registers in the SCI when interrupted

serial peripheral interface (SPI)

The SPI module is a built-in serial interface that facilitates communication between the network master, slave CPUs, and the external peripheral devices. The SPI module provides synchronous data transmission of up to 2.5 Mbps. Like the SCI, the SPI is set up by software. Once setup, the CPU takes no part in timing, data format, or protocol. Also, like the SCI, the CPU reads and writes to memory-mapped registers to receive and transmit data. An SPI interrupt alerts the CPU when received data is ready.

analog-to-digital converter (ADC1, ADC2, ADC3) modules

The 8-bit ADC modules perform successive approximation conversion. The term ADC is a general term used for ADC1, ADC2, and ADC3 modules. The ADCs offer the following number of input channels for each of the specified microcontroller families:

- ADC1 offers the following:
 - Four channels in the 40-pin devices of the 'x4x subfamily,
 - Eight channels in the 44-pin devices of the 'x4x, 'x32, and 'x36 subfamilies
 - Eight channels in the 64-pin and 68-pin devices of the 'x5x, 'x6x, 'x7x, and 'xBx subfamilies
- ADC2 offers four channels in the 28-pin devices of the 'xCx subfamily
- ADC3 offers 15 channels in the 40-pin and 44-pin devices of the 'x9x subfamily

The reference source and input channel are selectable. The user can program the conversion result to be the ratio of the input voltage to the reference voltage or the ratio of one analog input to another. Input lines that are not required for analog-to-digital conversion can be programmed to be digital input lines.

For a detailed explanation on any of the major components of the TMS370 device family, see the *TMS370 8-Bit Microcontroller User's Guide* (literature number SPNU127) or to the specific subfamily data sheet.

For more details on the programming of the TMS370 family or for further expansion on the applications of these devices, see the paragraph in this section on related documentation from Texas Instruments.

FUNCTIONAL-BLOCK-DIAGRAM GENERALIZATION

functional-block-diagram generalization

This section contains a functional-block-diagram generalization for the TMS370 microcontroller subfamilies (that is, 'x0x, 'x1x, 'x2x, 'x32, 'x36, 'x4x, ..., 'xCx). Because this diagram is a generalization, it depicts all the modules available for the TMS370 families, noting that no one TMS370 device contains all available options. The diagram also shows the basic internal connections among the major architectural features that are identified in the selection guide (see Table 4). For a functional block diagram of a specific TM370 subfamily, the pinouts, the descriptions of the pinouts, and descriptions of the external connection names, refer to the applicable data sheet.

FUNCTIONAL-BLOCK-DIAGRAM GENERALIZATION

functional-block-diagram generalization (continued)

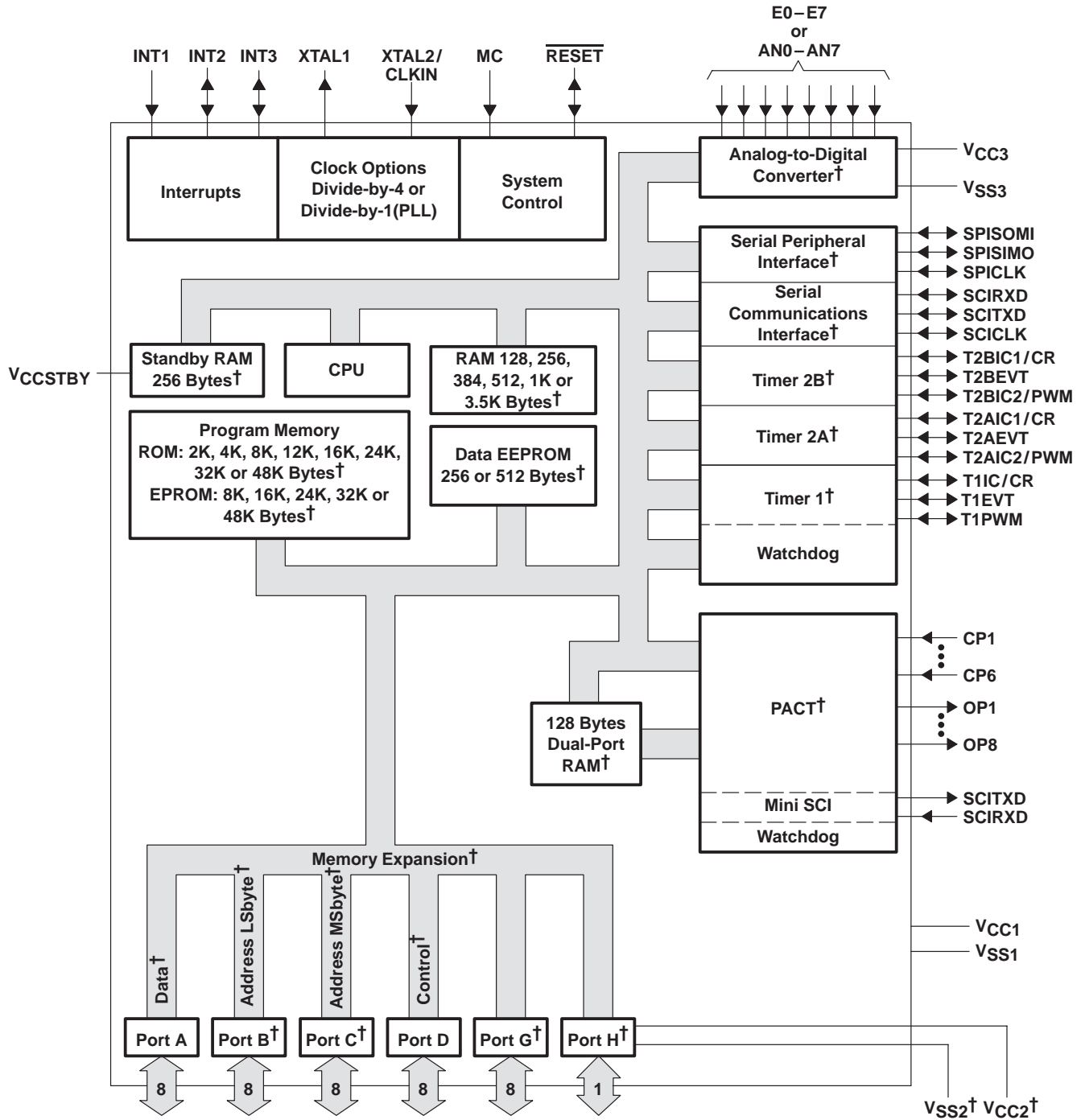

† Not available on all devices; see the selection reference guide (Table 4).

DEVICE-NUMBERING CONVENTIONS

device-numbering conventions

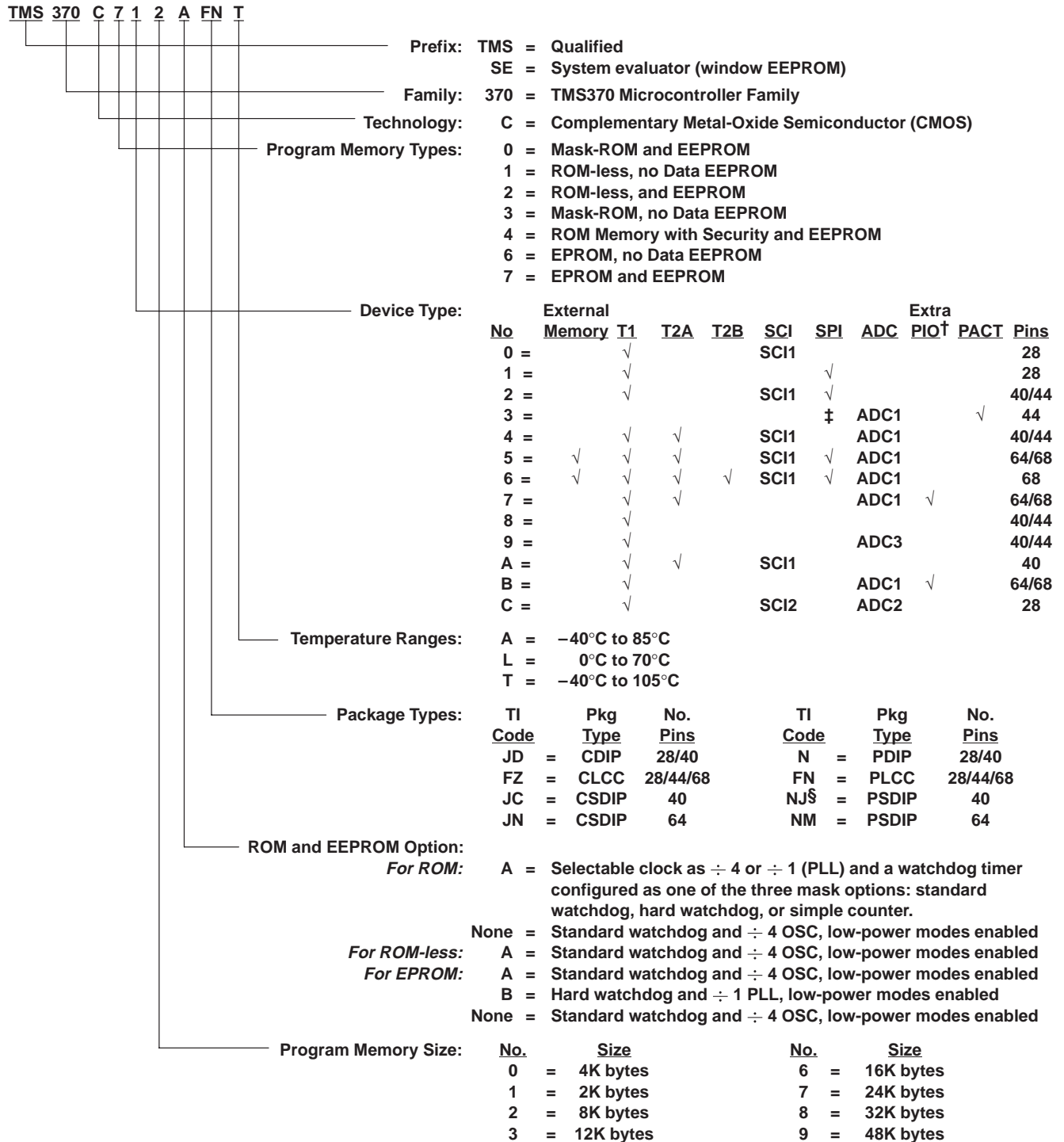

† Extra peripheral I/O

‡ For device type No. 3 the TMS370Cx32 device has no SPI; the TMS370Cx36 device has an SPI.

§ NJ package was formerly known as N2.

Figure 1. TMS370C Family Nomenclature

AVAILABLE DEVELOPMENT SYSTEM SUPPORT TOOLS

available development system support tools

The TMS370 family is fully supported by TI development tools that facilitate simplified software development for prompt market introduction of new products. These tools include an assembler, an optimizing C compiler, a linker, a C source debugger, a design kit, a starter kit, and a third-party microcontroller programmer from BP Microsystems. All of these tools work together by using an IBM-compatible PC as the host and central control element. This allows the user to select the host computer and text management as well as editing tools according to system requirements.

Additionally, the TMS370 in-circuit emulator (XDS and CDT370) allows the user to immediately begin designing, testing, and debugging the system upon specification. The reason for this is straightforward: the emulator itself is modular and configurable, thereby eliminating the need to produce a new emulator for each TMS370 configuration.

For a list of the available development system support tools, identified by device category, refer to the TMS370 Development System Support Tools table (see Table 5) or to the specific TMS370 subfamily data sheet.

For more detailed information on the development system support tools, refer to the *TMS370 8-Bit Microcontroller User's Guide* (literature number SPNU127) or to the documents listed in the section titled related documentation from Texas Instruments.

selection reference guide

The TMS370 8-Bit Microcontroller Product Selection Guide Configurations Table, commonly called the Selection Reference Guide (see Table 4), provides the user with an easy-to-use guide that includes the following specific device information by subfamilies: product family description (device type, part number, package and temperature options, and pin count); memory [program memory (ROM, EPROM), data memory (EEPROM, RAM) and any capability of off-chip memory expansion]; and peripherals (timers, serial interfaces, A/D channels, I/O, clock generators, and OTP and reprogrammable devices). The following symbol footnotes are used in Table 4:

- † Packages: FN = PLCC, FZ = CLCC, N = PDIP, JD = CDIP, NJ = PSDIP (formerly N2), JC = CSDIP, NM = PSDIP, JN = CSDIP
- ‡ Temperatures: ROM device types have L = 0°C to +70°C, A = -40°C to +85°C, and T = -40°C to +105°C temperature options; ROM-less, OTP and UV-EPROM device types only have T.
- § PACT SCI: PACT includes a mini-SCI. SCI1 module has 3-pin configuration while SCI2 module has 2-pin configuration.
- ¶ RAM: Includes 256 bytes of standby RAM
- # Memory: Includes secured memory feature
- || Max Freq: Supports maximum operating frequency of 3 MHz SYSCLK
- ☆ PACT WDOG: PACT includes a watchdog timer
- ADC1 Channels: 8 channels A/D for 44 pin package, 4 channels A/D for 40 pin package
- ◇ Timers: Timer 1 (T1) includes a watchdog timer programmable as a general purpose 16-bit timer
- Ψ44/40 Packages: 44 pins for FN, FZ packages. 40 pins for N, JD, NJ (formerly N2), JC packages.
- Φ68/64 Packages: 68 pins for FN, FZ packages. 64 pins for NM, JN packages
- ¥ TMS370CxCx SCI: Operable in asynchronous mode only
- △ Converter Socket: Requires a TMDS37788OTP converter socket
- ♣ Requires software modification (see the *TMS370CxBx Data Sheet* (literature number SPNS038))

Table 4 is a continuous table and only the applicable symbol footnotes are listed on each page.

development systems support tools

The TMS370 development system support tools listing shown in Table 5 identifies the available development support tools (by tool description and part number) for each of the TMS370 subfamilies ('x0x, 'x1x, 'x2x, 'x32, 'x36, ..., 'xCx).

SELECTION REFERENCE GUIDE

Table 4. TMS370 8-Bit Microcontroller Product Configurations

DEVICE TYPE†	PART NUMBER "yy" = PACKAGE "z" = TEMP	PACKAGE OPTIONS "yy"†	PACKAGE PIN COUNT	PROGRAM MEMORY (BYTES)		DATA MEMORY (BYTES)	OFF-CHIP MEM EXP (BYTES)	TIMERS‡	SERIAL INTERFACES	A/D CHANNELS	I/O	CLOCK GENERATOR	OTP AND REPROGRAMMABLE DEVICES
				ROM	EPROM								
TMS370C0x													
ROM	TMS370C302Ayyz	FN	28	8K		256		T1	SCI1		22	÷4 or PLL	C702
ROM	TMS370C002Ayyz	FN	28	8K		256		T1	SCI1		22	÷4 or PLL	C702
OTP	TMS370C702yyz	FN	28		8K	256		T1	SCI1		22	÷4	—
UV-EPROM	SE370C702yyz	FZ	28		8K	256		T1	SCI1		22	÷4	—
TMS370C1x													
ROM	TMS370C311Ayyz	FN/N	28	2K		128		T1	SPI		22	÷4 or PLL	C712
ROM	TMS370C310Ayyz	FN/N	28	4K		128		T1	SPI		22	÷4 or PLL	C712
ROM	TMS370C010Ayyz	FN/N	28	4K		256		T1	SPI		22	÷4 or PLL	C712
ROM	TMS370C312Ayyz	FN/N	28	8K		128		T1	SPI		22	÷4 or PLL	C712
ROM	TMS370C012Ayyz	FN/N	28	8K		256		T1	SPI		22	÷4 or PLL	C712
OTP	TMS370C712Ayyz	FN/N	28		8K	256		T1	SPI		22	÷4	—
OTP	TMS370C712Byyz	FN/N	28		8K	256		T1	SPI		22	PLL	—
UV-EPROM	SE370C712Ayyz	FZ/JD	28		8K	256		T1	SPI		22	÷4	—
UV-EPROM	SE370C712Byyz	FZ/JD	28		8K	256		T1	SPI		22	PLL	—
TMS370C2x													
ROM	TMS370C320Ayyz	FN/N/NJ	44/40 [‡]	4K		256		T1	SPI/SCI1		34	÷4 or PLL	C722
ROM	TMS370C322Ayyz	FN/N/NJ	44/40 [‡]	8K		256		T1	SPI/SCI1		34	÷4 or PLL	C722
ROM	TMS370C020Ayyz	FN/N/NJ	44/40 [‡]	4K		256		T1	SPI/SCI1		34	÷4 or PLL	C722
ROM	TMS370C022Ayyz	FN/N/NJ	44/40 [‡]	8K		256		T1	SPI/SCI1		34	÷4 or PLL	C722
OTP	TMS370C722yyz	FN/N/NJ	44/40 [‡]		8K	256		T1	SPI/SCI1		34	÷4	—
UV-EPROM	SE370C722yyz	FZ/JD/JC	44/40 [‡]		8K	256		T1	SPI/SCI1		34	÷4	—

† Packages: FN = PLCC, FZ = CLCC, N = PDIP, JD = CDIP, NJ = PSDIP (formerly N2), JC = CSDIP, NM = PSDIP, JN = CSDIP
 ‡ Temperatures: ROM device types have L = 0°C to +70°C, A = -40°C to +85°C, and T = -40°C to +105°C temperature options; ROM-less, OTP and UV-EPROM device types only have T.
 § PACT SCI: PACT includes a mini-SCI. SCI1 module has 3-pin configuration while SCI2 module has 2-pin configuration.
 † Timers: Timer 1 (T1) includes a watchdog timer programmable as a general purpose 16-bit timer
 ‡ 44/40 Packages: 44 pins for FN, FZ packages. 40 pins for N, JD, NJ (formerly N2), JC packages.

Table 4. TMS370 8-Bit Microcontroller Product Configurations (Continued)

DEVICE TYPE†	PART NUMBER "yy" = PACKAGE "z" = TEMP =TEMP	PACKAGE OPTIONS "yy"†	PACKAGE PIN COUNT	PROGRAM MEMORY (BYTES)		DATA MEMORY (BYTES)		OFF-CHIP MEM EXP (BYTES)	TIMERS‡	SERIAL INTERFACES§	A/D CHANNELS	I/O	CLOCK GENERATOR	OTP AND REPROGRAMMABLE DEVICES
				ROM	EPROM	EEPROM	RAM							
TMS370Cx3x														
ROM	TMS370C332Ayyz	FN	44	8K			256		PACT*☆	PACT	ADC1/8	23	-4 or PLL	C732
ROM	TMS370C032Ayyz	FN	44	8K		256	256		PACT*☆	PACT	ADC1/8	23	-4 or PLL	C732
ROM	TMS370C036Ayyz	FN	44	16K		256	512¶		PACT*☆	SPI/PACT	ADC1/8	25	-4 or PLL	C736
OTP	TMS370C732Ayyz	FN	44		8K		256		PACT*☆	PACT	ADC1/8	23	-4	—
OTP	TMS370C736Ayyz	FN	44		16K		512¶		PACT*☆	SPI/PACT	ADC1/8	25	-4	—
UV-EPROM	SE370C732Ayyz	FZ	44		8K		256		PACT*☆	PACT	ADC1/8	23	-4	—
UV-EPROM	SE370C736Ayyz	FZ	44		16K		512¶		PACT*☆	SPI/PACT	ADC1/8	25	-4	—
TMS370Cx4x														
ROM	TMS370C340Ayyz	FN/JN/NJ	44/40 ^ψ	4K			256		T1/T2a	SCI1	ADC1/8, 4□	36/32	-4 or PLL	C742
ROM	TMS370C342Ayyz	FN/JN/NJ	44/40 ^ψ	8K			256		T1/T2a	SCI1	ADC1/8, 4□	36/32	-4 or PLL	C742
ROM	TMS370C040Ayyz	FN/JN/NJ	44/40 ^ψ	4K		256	256		T1/T2a	SCI1	ADC1/8, 4□	36/32	-4 or PLL	C742
ROM	TMS370C042Ayyz	FN/JN/NJ	44/40 ^ψ	8K		256	256		T1/T2a	SCI1	ADC1/8, 4□	36/32	-4 or PLL	C742
OTP	TMS370C742Ayyz	FN/JN/NJ	44/40 ^ψ		8K		256		T1/T2a	SCI1	ADC1/8, 4□	36/32	-4	—
UV-EPROM	SE370C742Ayyz	FZ/JD/JC	44/40 ^ψ		8K		256		T1/T2a	SCI1	ADC1/8, 4□	36/32	-4	—
TMS370Cx5x														
ROM-less	TMS370C150Ayyz	FN	68				256	56K	T1/T2a	SPI/SCI1	ADC1/8	55	-4	C756
ROM-less	TMS370C250Ayyz	FN	68			256	256	56K	T1/T2a	SPI/SCI1	ADC1/8	55	-4	C756
ROM-less	TMS370C156Ayyz	FN	68				512	56K	T1/T2a	SPI/SCI1	ADC1/8	55	-4	C756
ROM-less	TMS370C256Ayyz	FN	68				512	56K	T1/T2a	SPI/SCI1	ADC1/8	55	-4	C756
ROM	TMS370C350Ayyz	FN/NM	68/64 ^φ	4K			256	112K	T1/T2a	SPI/SCI1	ADC1/8	55/53	-4 or PLL	C756
ROM	TMS370C050Ayyz	FN/NM	68/64 ^φ	4K		256	256	112K	T1/T2a	SPI/SCI1	ADC1/8	55/53	-4 or PLL	C756
ROM	TMS370C352Ayyz	FN/NM	68/64 ^φ	8K			256	112K	T1/T2a	SPI/SCI1	ADC1/8	55/53	-4 or PLL	C756
ROM	TMS370C052Ayyz	FN/NM	68/64 ^φ	8K		256	256	112K	T1/T2a	SPI/SCI1	ADC1/8	55/53	-4 or PLL	C756
ROM	TMS370C452Ayyz	FN	68	8K#			256	112K	T1/T2a	SPI/SCI1	ADC1/8	55	-4 or PLL	C756
ROM	TMS370C353Ayyz	FN	68	12K			1536	112K	T1/T2a	SPI/SCI1	ADC1/8	55	-4 or PLL	C759

† Packages: FN = PLCC, FZ = CLCC, N = PDIP, JD = CDIP, NJ = PSDIP (formerly N2), JC = CSDIP, NM = PSDIP, JN = CSDIP
 ‡ Temperatures: ROM device types have L = 0°C to +70°C, A = -40°C to +85°C, and T = -40°C to +105°C temperature options; ROM-less, OTP and UV-EPROM device types only have T.
 § PACT SCI: PACT includes a mini-SCI. SCI1 module has 3-pin configuration while SCI2 module has 2-pin configuration.
 ¶ RAM: Includes 256 bytes of standby RAM
 # Memory: Includes secured memory feature
 ☆ PACT WDOG: PACT includes a watchdog timer
 □ ADC1 Channels: 8 channels A/D for 44 pin package, 4 channels A/D for 40 pin package
 ◊ Timers: Timer 1 (T1) includes a watchdog timer programmable as a general purpose 16-bit timer
 ψ 44/40 Packages: 44 pins for FN, FZ packages; 40 pins for N, JD, NJ (formerly N2), JC packages.
 φ 68/64 Packages: 68 pins for FN, FZ packages; 64 pins for NM, JN packages

SELECTION REFERENCE GUIDE

Table 4. TMS370 8-Bit Microcontroller Product Configurations (Continued)

DEVICE TYPE†	PART NUMBER "yy" = PACKAGE "z" = TEMP	PACKAGE OPTIONS "yy"†	PACKAGE PIN COUNT	PROGRAM MEMORY (BYTES)		DATA MEMORY (BYTES)		OFF-CHIP MEM EXP (BYTES)	TIMERS‡	SERIAL INTERFACES	A/D CHANNELS	I/O	CLOCK GENERATOR	OTP AND REPROGRAMMABLE DEVICES
				ROM	EPROM	EPROM	RAM							
TMS370Cx5x (CONTINUED)														
ROM	TMS370C356Ayyz	FN/NM	68/64 ^Φ	16K			512	112K	T1/T2a	SPI/SCI1	ADC1/8	55/53	÷4 or PLL	C756
ROM	TMS370C456Ayyz	FN	68	16K [#]		512	512	112K	T1/T2a	SPI/SCI1	ADC1/8	55	÷4 or PLL	C756
ROM	TMS370C056Ayyz	FN/NM	68/64 ^Φ	16K		512	512	112K	T1/T2a	SPI/SCI1	ADC1/8	55/53	÷4 or PLL	C756
ROM	TMS370C358Ayyz	FN/NM	68/64 ^Φ	32K			1024	64K	T1/T2a	SPI/SCI1	ADC1/8	55/53	÷4 or PLL	C758
ROM	TMS370C058Ayyz	FN/NM	68/64 ^Φ	32K		256	1024	64K	T1/T2a	SPI/SCI1	ADC1/8	55/53	÷4 or PLL	C758
ROM	TMS370C059Ayyz	FN	68	48K		256	3584	20K	T1/T2a	SPI/SCI1	ADC1/8	55	÷4 or PLL	C759
OTP	TMS370C756Ayyz	FN/NM	68/64 ^Φ		16K	512	512	112K	T1/T2a	SPI/SCI1	ADC1/8	55/53	÷4	—
OTP	TMS370C758Ayyz	FN/NM	68/64 ^Φ		32K	256	1024	64K	T1/T2a	SPI/SCI1	ADC1/8	55/53	÷4	—
OTP	TMS370C758Byyz	FN/NM	68/64 ^Φ		32K	256	1024	64K	T1/T2a	SPI/SCI1	ADC1/8	55/53	PLL	—
OTP	TMS370C759Ayyz	FN	68	48K		256	3584	20K	T1/T2a	SPI/SCI1	ADC1/8	55	÷4	—
UV-EPROM	SE370C756Ayyz	FZ/JN	68/64 ^Φ	16K		512	512	112K	T1/T2a	SPI/SCI1	ADC1/8	55/53	÷4	—
UV-EPROM	SE370C758Ayyz	FZ/JN	68/64 ^Φ	32K		256	1024	64K	T1/T2a	SPI/SCI1	ADC1/8	55/53	÷4	—
UV-EPROM	SE370C758Byyz	FZ/JN	68/64 ^Φ	32K		256	1024	64K	T1/T2a	SPI/SCI1	ADC1/8	55/53	PLL	—
UV-EPROM	SE370C759Ayyz	FZ	68	48K		256	3584	20K	T1/T2a	SPI/SCI1	ADC1/8	55	÷4	—
TMS370Cx6x														
ROM	TMS370C067Ayyz	FN	68	24K		256	1024	24K	T1/T2a/T2b	SPI/SCI1	ADC1/8	55	÷4 or PLL	C768
ROM	TMS370C068Ayyz	FN	68	32K		256	1024	24K	T1/T2a/T2b	SPI/SCI1	ADC1/8	55	÷4 or PLL	C768
ROM	TMS370C069Ayyz	FN	68	48K		256	3584	8K	T1/T2a/T2b	SPI/SCI1	ADC1/8	55	÷4 or PLL	C769
OTP	TMS370C768Ayyz	FN	68			256	1024	24K	T1/T2a/T2b	SPI/SCI1	ADC1/8	55	÷4	—
OTP	TMS370C769Ayyz	FN	68	48K		256	3584	8K	T1/T2a/T2b	SPI/SCI1	ADC1/8	55	÷4	—
UV-EPROM	SE370C768Ayyz	FZ	68	32K		256	1024	24K	T1/T2a/T2b	SPI/SCI1	ADC1/8	55	÷4	—
UV-EPROM	SE370C769Ayyz	FZ	68	48K		256	3584	8K	T1/T2a/T2b	SPI/SCI1	ADC1/8	55	÷4	—

† Packages: FN = PLCC, FZ = CLCC, N = PDIP, JD = CDIP, NJ = PSDIP (formerly N2), JC = CSDIP, NM = PSDIP, JN = CSDIP
 ‡ Temperatures: ROM device types have L = 0°C to +70°C, A = -40°C to +85°C, and T = -40°C to +105°C temperature options; ROM-less, OTP and UV-EPROM device types only have T.
 § PACT SCI: PACT includes a mini-SCI. SCI1 module has 3-pin configuration while SCI2 module has 2-pin configuration.
 || Max Freq: Supports maximum operating frequency of 3 MHz SYSCLK
 ◇ Timers: Timer 1 (T1) includes a watchdog timer programmable as a general purpose 16-bit timer
 Φ 68/64 Packages: 68 pins for FN, FZ packages; 64 pins for NM, JN packages

Table 4. TMS370 8-Bit Microcontroller Product Configurations (Continued)

DEVICE TYPE†	PART NUMBER "yy" = PACKAGE "z" = TEMP	PACKAGE OPTIONS "yy"†	PACKAGE PIN COUNT	PROGRAM MEMORY (BYTES)		DATA MEMORY (BYTES)		OFF-CHIP MEM EXP (BYTES)	TIMERS‡	SERIAL INTERFACES§	A/D CHANNELS	I/O	CLOCK GENERATOR	OTP AND REPROGRAMMABLE DEVICES
				ROM	EPROM	EEPROM	RAM							
TMS370Cx7x														
ROM	TMS370C077Ayyz	FN/NM	68/64 ^Φ	24K		256	512		T1/T2a		ADC1/8	55/53	÷4 or PLL	C777
OTP	TMS370C777Ayyz	FN/NM	68/64 ^Φ		24K	256	512		T1/T2a		ADC1/8	55/53	÷4	—
UV-EPROM	SE370C777Ayyz	FZ/JN	68/64 ^Φ		24K	256	512		T1/T2a		ADC1/8	55/53	÷4	—
TMS370Cx8x														
ROM	TMS370C380Ayyz	FN	44	4K			128		T1			35	÷4 or PLL	C686
ROM	TMS370C080yyz	N	40	4K		256	128		T1			33	÷4	C758 ^Δ
OTP	TMS370C686Ayyz	FN	44	16K			256		T1			35	÷4	—
UV-EPROM	SE370C686Ayyz	FZ	44	16K			256		T1			35	÷4	—
TMS370Cx9x														
ROM	TMS370C090Ayyz	FN/NJ	44/40 ^Ψ	4K		256	128		T1		ADC3/15	25	÷4 or PLL	C792
OTP	TMS370C792yyz	FN/NJ	44/40 ^Ψ		8K	256	128		T1		ADC3/15	25	÷4	—
UV-EPROM	SE370C792yyz	FZ/JC	44/40 ^Ψ		8K	256	128		T1		ADC3/15	25	÷4	—
TMS370CxAx														
ROM	TMS370C3A7Ayyz	N	40	24K			512		T1/T2a	SCI1		34	÷4 or PLL	C758 ^Δ
TMS370CxBx														
ROM	TMS370C0B6Ayyz	FN/NM	68/64 ^Φ	16K		256	384		T1		ADC1/8	55/53	÷4 or PLL	C758*
TMS370CxCx														
ROM	TMS370C3C0Ayyz	FN/N	28	4K			128		T1	SCI2 [‡]	ADC2/4	22	÷4 or PLL	C6C2
OTP	TMS370C6C2Ayyz	FN/N	28	8K			128		T1	SCI2 [‡]	ADC2/4	22	÷4	—
UV-EPROM	SE370C6C2Ayyz	FZ/JD	28	8K			128		T1	SCI2 [‡]	ADC2/4	22	÷4	—

† Packages: FN = PLCC, FZ = CLCC, N = PDIP, NJ = CDIP, NJ = PSDIP (formerly N2), JC = CSDIP, NM = PSDIP, JN = CSDIP
 ‡ Temperatures: ROM device types have L = 0°C to +70°C, A = -40°C to +85°C, and T = -40°C to +105°C temperature options; ROM-less, OTP and UV-EPROM device types only have T.
 § PACT SCI: PACT includes a mini-SCI. SCI1 module has 3-pin configuration while SCI2 module has 2-pin configuration.
 ¶ Timers: Timer 1 (T1) includes a watchdog timer programmable as a general purpose 16-bit timer
 Ψ 44/40 Packages: 44 pins for FN, FZ packages. 40 pins for N, JD, NJ (formerly N2), JC packages.
 Φ 68/64 Packages: 68 pins for FN, FZ packages. 64 pins for NM, JN packages
 † TMS370CxCx SCI: Operable in asynchronous mode only
 Δ Converter Socket: Requires a TMS37788OTP converter socket
 * Requires software modification [see the TMS370CxBx Data Sheet (literature number SPNS038)]

DEVELOPMENT SYSTEMS SUPPORT TOOLS

Table 5. TMS370 Development System Support Tools

DEVELOPMENT TOOL DESCRIPTION	PART NUMBER	x0x	x1x	x2x	x32	x36	x4x	x5x	x6x	x7x	x8x	x9x	xAx	xBx	xCx
Assembler/Linker (PC)	TMDS3740850-02	✓	✓	✓	✓	✓	✓	✓	✓	✓	✓	✓	✓	✓	✓
C-Compiler, Assem/Link (PC)	TMDS3740855-02	✓	✓	✓	✓	✓	✓	✓	✓	✓	✓	✓	✓	✓	✓
C-Compiler, Assem/Link (WS)	TMDS3740555-09	✓	✓	✓	✓	✓	✓	✓	✓	✓	✓	✓	✓	✓	✓
TMS370 Starter Kit	TMDS37000	✓	✓	✓	✓	✓	✓	✓	✓	✓	✓	✓	✓	✓	✓
TMS370 Design Kit	TMDS3770110	✓	✓	✓	✓	✓	✓	✓	✓	✓	✓	✓	✓	✓	✓
TMS370 Compact Development Tool															
CDT370	EDSCDT370	✓	✓	✓	✓	✓	✓	✓	✓	✓	✓	✓	✓	✓	✓
CDT370 PACT	EDSCDT37P	—	—	—	✓	—	—	—	—	—	—	✓	—	—	—
CDT370 Timer	EDSCDT37T	—	—	—	—	—	—	—	✓	✓	—	—	—	✓	—
CDT Target Cables															
28-Pin PLCC (x0x)	EDSTRG28PLCC02	✓	—	—	—	—	—	—	—	—	—	—	—	—	—
28-Pin DIP (x1x)	EDSTRG28DIL	—	✓	—	—	—	—	—	—	—	—	—	—	—	—
28-Pin PLCC (x1x)	EDSTRG28PLCC	—	✓	—	—	—	—	—	—	—	—	—	—	—	—
40-Pin DIP (x2x)	EDSTRG40DILX	—	—	✓	—	—	—	—	—	—	—	—	—	—	—
44-Pin PLCC (x2x)	EDSTRG44PLCCX	—	—	✓	—	—	—	—	—	—	—	—	—	—	—
40-Pin SDIP (x2x)	EDSTRG40SDILX	—	—	✓	—	—	—	—	—	—	—	—	—	—	—
44-Pin PLCC (x32)	EDSTRG44PLCC32	—	—	—	✓	—	—	—	—	—	—	—	—	—	—
44-Pin PLCC (x36)	EDSTRG44PLCC36	—	—	—	—	✓	—	—	—	—	—	—	—	—	—
40-Pin DIP (x4x)	EDSTRG40DIL	—	—	—	—	—	✓	—	—	—	—	—	—	—	—
44-Pin PLCC (x4x)	EDSTRG44PLCC	—	—	—	—	—	✓	—	—	—	—	—	—	—	—
40-Pin SDIP (x4x)	EDSTRG40SDIL	—	—	—	—	—	✓	—	—	—	—	—	—	—	—
68-Pin PLCC (x5x, x6x, x7x, xBx)	EDSTRG68PLCC	—	—	—	—	—	—	✓	—	✓	—	—	—	—	—
64-Pin SDIP (x5x, x7x, xBx)	EDSTRG64SDIL	—	—	—	—	—	—	✓	—	✓	—	—	—	—	—
40-Pin DIP (x8x)	EDSTRG40DIL8X	—	—	—	—	—	—	—	—	—	✓	—	—	—	—
44-Pin PLCC (x8x)	EDSTRG44PLCC8X	—	—	—	—	—	—	—	—	—	✓	—	—	—	—
40-Pin SDIP (x9x)	EDSTRG40SDIL05	—	—	—	—	—	—	—	—	—	—	✓	—	—	—
44-Pin PLCC (x9x)	EDSTRG44PLCC05	—	—	—	—	—	—	—	—	—	—	✓	—	—	—
40-Pin DIP (xAx)	EDSTRG40DILAX	—	—	—	—	—	—	—	—	—	—	—	✓	—	—
28-Pin PLCC (xCx)	EDSTRG28PLCCCX	—	—	—	—	—	—	—	—	—	—	—	—	—	✓
28-Pin DIP (xCx)	EDSTRG28DILCX	—	—	—	—	—	—	—	—	—	—	—	—	—	✓

Table 5. TMS370 Development System Support Tools (Continued)

DEVELOPMENT TOOL DESCRIPTION	PART NUMBER	x0x	x1x	x2x	x32	x36	x4x	x5x	x6x	x7x	x8x	x9x	xAx	xBx	xCx
TMS370 XDS/22 Emulator	TMD3762210	—	√	√	—	—	√	√	—	—	—	—	—	—	—
XDS Target Cable															
28-Pin DIP/PLCC	TMDS3788828	—	√	—	—	—	—	—	—	—	—	—	—	—	—
40-Pin DIP/SDIP, 44-Pin PLCC	TMDS3788844	—	—	√	—	—	√	—	—	—	—	—	—	—	—
68-Pin PLCC, 64-Pin SDIP	TMDS3788868	—	—	—	—	—	—	√	—	—	—	—	—	—	—
Converter Socket (from '758 to '080 or '3A7)	TMDS377880TP	—	—	—	—	—	—	—	—	—	√	—	√	—	—
Programming Solutions															
BP1148TI Base	TMDS3760500A	√	√	√	√	√	√	√	√	√	√	√	√	√	√
Top/DIP (40-Pin DIP/SDIP, 28-Pin DIP, 64-Pin SDIP)	TMDS3780511A	—	√	√	—	—	√	√	—	√	√	—	√	√	—
Top/PLCC (44-Pin PLCC, 28-Pin PLCC, 68-Pin PLCC)	TMDS3780510A	√	√	√	√	—	√	√	—	√	√	—	—	√	—
Top/x36 (44-Pin PLCC x36)	TMDS3700572A	—	—	—	—	√	—	—	√	—	—	—	—	—	—
Top/x9x (44-Pin PLCC/40-Pin SDIP x9x)	TMDS3780513A	—	—	—	—	—	—	—	—	—	—	√	—	—	—
Top/xCx (28-Pin PLCC/DIP xCx)	TMDS3780514A	—	—	—	—	—	—	—	—	—	—	—	—	—	√

For more information on the key features of the TMS370 Development Tools and their current availability for PC-DOS and MS-DOS systems, see the *TMS370 8-Bit Microcontroller User's Guide* (literature number SPNU127).

third-party support

COMPANY	ADDRESS	PHONE NUMBER	TOOL	ENVIRONMENT
Allen Ashley	395 Sierra Madre Villa Pasadena, CA 91107	(818) 793-5748	Assembler/Linker	PC/MS-DOS
BP Microsystems	1000 North Post Oak Rd., Suite 225 Houston, TX 77055	(713) 688-4600 (800) 225-2102	Support (with adaptor top from TI) BP1148TI, BP1200 and BP2100 programmers	PC/MS-DOS
Data I/O	10525 Willows Rd., NE Redmond, WA 98073	(206) 881-6444	Programmers for TMS370; 3900, 2900 and Unisite	PC/MS-DOS
Logical Devices	130 Capitol Drive, Suites A & B Golden, CO 80401	(303) 279-6868	TMS370 Microcontroller Module for ALLPRO Programmers	ALLPRO Programmers
System General	1603 A South Main St. Milpitas, CA 95035	(408) 263-6667 (408) 263-6668	Support with Turpro-1/FX, Turpro-1/TX, Turpro-1, APPO, Turpro-832, and Turpro-840 programmers	PC/MS-DOS and Standalone

OPERATING CONDITIONS AND CHARACTERISTICS

operating conditions and characteristics

This section defines the current and voltage operating conditions and characteristics.

current

high-level input current, I_{IH}

The current into an input when a high-level voltage is applied to that input.

high-level output current, I_{OH}

The current into an output with input conditions applied that, according to the product specification, establishes a high level at the output.

low-level input current, I_{IL}

The current into an input when a low-level voltage is applied to that input.

low-level output current, I_{OL}

The current into an output with input conditions applied that, according to the product specification, establishes a low level at the output.

supply current, I_{CC} , I_{CC2} , I_{CC3} , I_{PP} , I_{CCSTBY}

The current into, respectively, the ($V_{CC}=V_{CC1}$), V_{CC2} , V_{CC3} , V_{PP} , V_{CCSTBY} supply terminals.

operating free-air temperature, T_A

The temperature range over which the device operates and the range which meets the specified electrical characteristics.

voltage

high-level input voltage, V_{IH}

An input voltage within the more positive (less negative) of the two ranges of values used to represent the binary variables.

NOTE: A minimum is specified that is the least positive value of high-level input voltage for which of the logic element within specification limits is assured.

high-level output voltage, V_{OH}

The voltage at an output terminal with input conditions applied that, according to the product specification, establishes a high level at the output.

low-level input voltage, V_{IL}

An input voltage level within the less positive (more negative) of the two ranges of values is used to represent the binary variables.

NOTE: The most positive value of low-level input voltage is specified for which operation of the logic element within specification limits is assured.

low-level output voltage, V_{OL}

The voltage at an output terminal with input conditions applied that, according to the product specification, establishes a low level at the output.

supply voltages, ($V_{CC}=V_{CC1}$), V_{CC2} , V_{CC3} , V_{PP} , and V_{CCSTBY}

The voltages supplied to the corresponding voltage pins that are required for the device to function. One to four of these supplies may be necessary, along with ground(s) ($V_{SS}=V_{SS1}$, V_{SS2} , and V_{SS3}).

timing conventions

This section defines the timing parameters, including cycle time, hold time, pulse duration, and others.

time intervals

New or revised data sheets in this book use letter symbols in accordance with standards recently adopted by JEDEC, the IEEE, and the IEC. Two basic forms of symbols are used. The first form is used usually when intervals can be classified easily as cycle, hold, setup, transition, valid, or delay times and for pulse durations. The second form can be used generally, but in this book the second form is primarily for time intervals not easily classifiable. The second (unclassified) form is described first. Since some manufacturers use this form for all time intervals, symbols in the unclassified form are given with the examples for most of the classified time intervals.

unclassified time intervals

Generalized letter symbols can be used to identify almost any time interval without classifying it using traditional or contrived definitions. Symbols for unclassified time intervals identify two signal events listed in from-to sequence using the format:

$t_{(AB-CD)}$

Subscripts A and C indicate the names of the signals for which changes of state or level or establishment of state or level constitute signal events assumed to occur first and last, respectively, that is, at the beginning and end of the time interval.

Subscripts B and D indicate the direction of the transitions and/or the final states or levels of the signals represented by A and C, respectively. One or two of the following is used:

- H = high or transition to high
- L = low or transition to low
- V = a valid steady-state level
- X = unknown, changing, or “don’t care” level
- Z = high-impedance (off) state

The hyphen between the B and C subscripts is omitted when no confusion is likely to occur.

classified time intervals

Because of the information contained in the definitions, frequently the identification of one or both of the two signal events that begin and end the intervals can be shortened significantly compared to the unclassified forms. For example, it is not necessary to indicate in the symbol that an access time ends with valid data at the output. However, if both signals are named (e.g., in a hold time), the from-to sequence is maintained.

cycle time

The time interval between the start and end of a cycle.

NOTE: For each cycle time (t_c), the value given represents the minimum time interval required to complete one cycle of the given function (e.g., read, write, etc.) correctly.

Example symbology:

Classified	Description
t_c	Cycle time, (SYSCLK)
$t_c(\text{SPC})$	Cycle time, (SPICLK)
$t_c(\text{SCC})$	Cycle time, (SCICLK)

TIMING CONVENTIONS

hold time

The time interval during which a signal is retained at a specified input terminal after an active transition occurs at another specified input terminal.

- NOTES:
1. The hold time is the actual time interval between two signal events and is determined by the system in which the digital circuit operates. A minimum value is specified that is the shortest interval for which correct operation of the digital circuit is assured.
 2. The hold time can have a negative value in which case the minimum limit defines the longest interval (between the release of the signal and the active transition) for which correct operation of the digital circuit is assured.

Example symbology:

Classified	Description
$t_{h(EH-A)}$	Hold time, address, R/ \overline{W} and \overline{OCF} from \overline{EDS} , $\overline{CSE1}$, $\overline{CSE2}$, $\overline{CSH1}$, $\overline{CSH2}$, $\overline{CSH3}$, and \overline{CSPF} high
$t_{h(EH-D)W}$	Hold time, write data time from \overline{EDS} high
$t_{h(EH-D)R}$	Hold time, read time from \overline{EDS} high
$t_{h(SCH-WT)}$	Hold time, \overline{WAIT} time from SYSCLK high
$t_{h(AN)}$	Hold time, analog input from start of conversion

NOTE: The from-to sequence in the order of subscripts in the unclassified form is maintained in the classified form. In the case of hold times, this causes the order to seem reversed from what would be suggested by the terms.

pulse duration (width)

The time interval between the specified reference points on the leading and trailing edges of the pulse waveform.

Example symbology:

Classified	Description
$t_w(CI)$	Pulse duration, XTAL2/CLKIN
$t_w(PGM)B$	Pulse duration, programming signal to ensure valid data is stored (byte mode)
$t_w(PGM)AR$	Pulse duration, programming signal to ensure valid data is stored (array mode)
$t_w(EPGM)$	Pulse duration, programming signal
$t_w(SCL)$	Pulse duration, SYSCLK low
$t_w(SCH)$	Pulse duration, SYSCLK high
$t_w(SCCL)$	Pulse duration, SCICLK low
$t_w(SCCH)$	Pulse duration, SCICLK high
$t_w(SPCL)$	Pulse duration, SPICLK low
$t_w(SPCH)$	Pulse duration, SPICLK high
$t_w(S)$	Pulse duration, sample time per kilohm of source impedance
t_w	Pulse duration, \overline{EDS} , $\overline{CSE1}$, $\overline{CSE2}$, $\overline{CSH1}$, $\overline{CSH2}$, $\overline{CSH3}$, and \overline{CSPF} low

setup time

The time interval between the application of a signal at a specified input terminal and a subsequent active transition at another specified input terminal.

- NOTES:
1. The setup time is the actual time interval between two signal events and is determined by the system in which the digital circuit operates. A minimum value is specified that is the shortest interval for which correct operation of the digital circuit is assured.
 2. The setup time can have a negative value in which case the minimum limit defines the longest interval (between the active transition and the application of the other signal) for which correct operation of the digital circuit is assured.

Example symbology:

Classified	Description
$t_{su(D)}$	Setup time, write data time to \overline{EDS} high
$t_{su(WT-SCH)}$	Setup time, \overline{WAIT} time to SYSCLK high
$t_{su(RXD-SCCH)}$	Setup time, SCIRXD to SCICLK high
$t_{su(SOMI-SPCH)}$	Setup time, SPISOMI to SPICLK high (polarity = 1)
$t_{su(SIMO-SPCH)}$	Setup time, SPISIMO to SPICLK high (polarity = 1)
$t_{su(S)}$	Setup time, analog to sample command

transition times (rise and fall times)

The time interval between two reference points (10% and 90% unless otherwise specified) on the same waveform that is changing from the defined low level to the defined high level (rise time) or from the defined high level to the defined low level (fall time).

Example symbology:

Classified	Description
t_r	Rise time
t_f	Fall time
$t_r(CI)$	Rise time, XTAL2/CLKIN
$t_f(CI)$	Fall time, XTAL2/CLKIN

valid time

- General. The time interval during which a signal is (or should be) valid.
- Output data-valid time. The time interval in which output data continues to be valid following a change of input conditions that could cause the output data to change at the end of the interval.

Example symbology:

Classified	Description
$t_v(A)$	Valid time, address to \overline{EDS} , $\overline{CSE1}$, $\overline{CSE2}$, $\overline{CSH1}$, $\overline{CSH2}$, $\overline{CSH3}$ and \overline{CSPF} low
$t_v(SCCH-TXD)$	Valid time, SCITXD data valid after SCICLK high
$t_v(SCCH-RXD)$	Valid time, SCIRXD data valid after SCICLK high
$t_v(SPCH-SOMI)$	Valid time, SPISOMI data valid after SPICLK high (polarity = 1)
$t_v(SPCH-SIMO)$	Valid time, SPISIMO data valid after SPICLK high (polarity = 1)

$t_v(AB-CD)$ supersedes the older form t_{pVX} .

TIMING CONVENTIONS





delay time

The time interval between two signals identified in the description column of the following example symbology.

Example symbology:

Classified	Description
$t_d(\text{CIH-SCL})$	Delay time, XTAL2/CLKIN rise to SYSCLK fall
$t_d(\text{CIH-SCH})$	Delay time, XTAL2/CLKIN rise to SYSCLK rise
$t_d(\text{SCL-A})$	Delay time, SYSCLK low to address R/\overline{W} and \overline{OCF} valid
$t_d(\text{DZ-EL})$	Delay time, data bus high impedance to \overline{EDS} low (read cycle)
$t_d(\text{EH-D})$	Delay time, \overline{EDS} high to data bus enable (read cycle)
$t_d(\text{EL-DV})R$	Delay time, \overline{EDS} low to read data valid
$t_d(\text{EL-WTV})$	Delay time, \overline{EDS} low to \overline{WAIT} valid
$t_d(\text{AV-DV})R$	Delay time, address valid to read data valid
$t_d(\text{AV-WTV})$	Delay time, address valid to \overline{WAIT} valid
$t_d(\text{AV-EH})$	Delay time, address valid to \overline{EDS} high (end of write)
$t_d(\text{SCCL-TXDV})$	Delay time, SCITXD valid after SCICLK low
$t_d(\text{SPCL-SIMOV})$	Delay time, SPISIMO valid after SPICLK low (polarity = 1)
$t_d(\text{SPCL-SOMIV})$	Delay time, SPISOMI valid after SPICLK low (polarity = 1)

timing-diagram conventions

Timing-Diagram Symbol	Meaning	
	Input Forcing Functions	Output Response Functions
	Must be steady high or low	Will be steady high or low
	High-to-low changes permitted	Will be changing from high to low sometime during designated intervals
	Low-to-high changes permitted	Will be changing from low to high sometime during designated intervals
	Don't care	State unknown or changing

RELATED DOCUMENTATION FROM TEXAS INSTRUMENTS

related documentation from Texas Instruments

The following books describe the TMS370 family devices and related support tools. To obtain a copy of any of these TI documents, call the Texas Instruments Literature Response Center at (800) 477-8924. When ordering, please identify the book by its title and literature number.

TMS370 Family Assembly Language Tools User's Guide (literature number SPNU010) describes the assembly language tools (assembler, linker, and other tools used to develop assembly code), assembler directives, macros, common object-file format, and symbolic debugging directives for the '370 family of devices.

TMS370 Family Optimizing C Compiler User's Guide (literature number SPNU022) describes the '370 C compiler. This C compiler accepts ANSI standard C source code and produces assembly language source code for the '370 family of devices.

TMS370 Family C Source Debugger User's Guide (literature number SPNU028) tells you how to invoke the TMS370 family application board and XDS versions of the C source debugger interface. This book discusses various aspects of the debugger interface, including window management, command entry, code execution, data management, and breakpoints. It also includes a tutorial that introduces basic debugger functionality.

TMS370 Microcontroller Family User's Guide (literature number SPNU127) describes the TMS 370 family of microcontroller devices and provides the user with the information needed to implement a microcontroller design using a TMS370 device.

TMS370 Microcontroller Family Applications Book (literature number SPNA017) provides examples of hardware interfaces and software routines for the TMS370 family of microcontrollers.

FOR FURTHER ASSISTANCE

for further assistance

<input type="checkbox"/> World-Wide Web Sites			
TI Online		http://www.ti.com	
Semiconductor Product Information Center (PIC)		http://www.ti.com/sc/docs/pic/home.htm	
DSP Solutions		http://www.ti.com/dsps	
320 Hotline On-line™		http://www.ti.com/sc/docs/dsps/support.htm	
Microcontroller Home Page		http://www.ti.com/sc/micro	
Networking Home Page		http://www.ti.com/sc/docs/network/nbuhomex.htm	
<input type="checkbox"/> North America, South America, Central America			
Product Information Center (PIC)	(972) 644-5580		
TI Literature Response Center U.S.A.	(800) 477-8924		
Software Registration/Upgrades	(214) 638-0333	Fax: (214) 638-7742	
U.S.A. Factory Repair/Hardware Upgrades	(281) 274-2285		
U.S. Technical Training Organization	(972) 644-5580		
Microcontroller Hotline	(281) 274-2370	Fax: (281) 274-4203	Email: micro@ti.com
Microcontroller Modem BBS	(281) 274-3700 8-N-1		
DSP Hotline	(281) 274-2320	Fax: (281) 274-2324	Email: dsph@ti.com
DSP Modem BBS	(281) 274-2323		
DSP Internet BBS via anonymous ftp to ftp://ftp.ti.com/pub/tms320bbs			
Networking Hotline		Fax: (281) 274-4027	Email: TLANHOT@micro.ti.com
<input type="checkbox"/> Europe, Middle East, Africa			
European Product Information Center (EPIC) Hotlines:			
Multi-Language Support	+33 1 30 70 11 69	Fax: +33 1 30 70 10 32	Email: epic@ti.com
Deutsch	+49 8161 80 33 11 or +33 1 30 70 11 68		
English	+33 1 30 70 11 65		
Francais	+33 1 30 70 11 64		
Italiano	+33 1 30 70 11 67		
EPIC Modem BBS	+33 1 30 70 11 99		
European Factory Repair	+33 4 93 22 25 40		
Europe Customer Training Helpline		Fax: +49 81 61 80 40 10	
<input type="checkbox"/> Asia-Pacific			
Literature Response Center	+852 2 956 7288	Fax: +852 2 956 2200	
Hong Kong DSP Hotline	+852 2 956 7268	Fax: +852 2 956 1002	
Korea DSP Hotline	+82 2 551 2804	Fax: +82 2 551 2828	
Korea DSP Modem BBS	+82 2 551 2914		
Singapore DSP Hotline		Fax: +65 390 7179	
Taiwan DSP Hotline	+886 2 377 1450	Fax: +886 2 377 2718	
Taiwan DSP Modem BBS	+886 2 376 2592		
Taiwan DSP Internet BBS via anonymous ftp to ftp://dsp.ee.tit.edu.tw/pub/TI/			
<input type="checkbox"/> Japan			
Product Information Center	+0120-81-0026 (in Japan)	Fax: +0120-81-0036 (in Japan)	
	+03-3457-0972 or (INTL) 813-3457-0972	Fax: +03-3457-1259 or (INTL) 813-3457-1259	
DSP Hotline	+03-3769-8735 or (INTL) 813-3769-8735	Fax: +03-3457-7071 or (INTL) 813-3457-7071	
DSP BBS via Nifty-Serve	Type "Go TIASP"		
<input type="checkbox"/> Documentation			
When making suggestions or reporting errors in documentation, please include the following information that is on the title page: the full title of the book, the publication date, and the literature number.			
Mail: Texas Instruments Incorporated		Email: comments@books.sc.ti.com	
Technical Documentation Services, MS 702			
P.O. Box 1443			
Houston, Texas 77251-1443			

Note: When calling a Literature Response Center to order documentation, please specify the literature number of the book.

glossary/symbols, terms, and definitions

A

absolute addressing mode: An addressing mode in which code or operands produce the actual address

address: Any given memory location in which data can be stored or from which data can be retrieved

addressing mode: The method by which an instruction calculates the location of its required data

analog-to-digital converter (ADC): An 8-bit successive-approximation converter with internal sample-and-hold circuitry. Also referred to as ADC1, ADC2, or ADC3. ADC1 is an 8-channel ADC, except for the 40-pin TMS370Cx4x devices which have only four channels. ADC2 is a 4-channel ADC. And ADC3 is a 15-channel ADC.

ANSI C: A version of the C programming language that conforms to the C standards defined by the *American National Standards Institute*

archiver: A software program that allows the collection of several individual files into a single file called an archive library. The archiver also allows the addition, deletion, extraction, or replacement of members of the archive library.

assembler: A software program that creates a machine-language program from a source file containing assembly language instructions, directives, and macro directives. The assembler substitutes absolute operation codes for symbolic operation codes, and absolute or relocatable addresses for symbolic addresses.

assembly language: A symbolic language that describes the binary machine code in a more readable form. Each of the 73 unique instructions of the TMS370 family converts to one machine operation.

asynchronous-communications mode: An SCI mode that needs no synchronizing clock. The asynchronous communications mode format consists of a start bit followed by data bits, an optional parity bit, and a stop bit. This format commonly is used with RS-232-C communications and PC serial ports.

B

baud: The communication speed for serial ports; equivalent to bits per second

BCD: *Binary coded decimal*. Each 4-bit nibble expresses a digit from 0–9 and usually packs two digits to a byte, giving a range of 0–99.

bit: Contraction of *binary digit* i.e., a 1 or a 0. In electrical terms, the value of a bit can be represented by the presence or absence of charge, voltage, or current.

breakpoint, trace, and timing (BTT) features: A set of features supported by the BTT board (included with the XDS/22 emulation system). These features allow the setting of hardware breakpoints, collecting of trace samples, and performing timing analysis.

buffer pointer: A 5-bit register in the PACT module peripheral frame that points to the next available location in the circular-capture buffer

byte: A sequence of eight adjacent bits operated upon as a unit

GLOSSARY/SYMBOLS, TERMS, AND DEFINITIONS

C

C: A high-level, general-purpose programming language that is useful for writing compilers and operating systems and for programming microprocessors

C compiler: A program that translates C source statements into assembly language source statements

capture register: A timer 2n register that is loaded with the 16-bit counter value on the occurrence of an external input transition. Either edge of the external input can be configured to trigger the capture.

CDIP: Ceramic Dual In-Line Package

CDT370: A low-cost code-development tool that is external to the target system and provides direct control over the TMS370 processor that is on the target system

chip select: For some blocks of the TMS370 memory map, the most significant bits of the address are pre-decoded to activate chip-select signals. These chip-select signals allow the TMS370 to access external addresses with a minimum of external logic and to perform memory bank selection under software control.

circular buffer: A variable length area in the PACT module dual-port RAM that stores the value of a PACT timer when a capture request is made. As new values are captured, they are put into successive locations in the buffer. When the buffer is full, the oldest captures are replaced with newer captures.

CLCC: Ceramic Leaded Chip Carrier

CMOS: A complementary MOS technology that uses transistors with electron (N-channel) and hole (P-channel) conduction

code conversion utility: A software program that translates a COFF file into one of several standard ASCII hexadecimal formats suitable for loading into an EPROM programmer

COFF: *Common Object File Format*. An implementation of the object file format of the same name developed by AT&T. The TMS370 compiler, assembler, and linker use and generate COFF files.

command/definition area: A variable length area in the PACT module dual-port RAM that is used to define the actions taken by the PACT module

comment: A source statement (or portion of a source statement) that documents or improves the readability of a source file. Comments are not compiled, assembled, or linked; they have no effect on the object file.

compare register: A timer 1 or timer 2n register that contains a value that is compared to the counter value. The compare function triggers when the counter matches the contents of the compare register.

constant: A value that does not change during execution

CPU: An 8-bit register-oriented processor with a status register, program counter, and stack pointer. The TMS370 CPU uses the register file, accessed in one bus cycle, as working registers.

CSDIP: Ceramic Shrink Dual In-Line Package

$\overline{\text{CSE1}}$: Chip-Select Eighth 1. This signal selects the first bank of memory. It has the same timing as $\overline{\text{EDS}}$. Setting this pin to a high-level general-purpose output disables the bank.

$\overline{\text{CSE2}}$: Chip-Select Eighth 2. This signal selects the second bank of memory. It has the same timing as $\overline{\text{EDS}}$. Setting this pin to a high-level general-purpose output disables the bank.

$\overline{\text{CSH1}}$: Chip-Select Half 1. This signal selects the first bank of memory. It has the same timing as $\overline{\text{EDS}}$. Setting this pin to a high-level general-purpose output disables the bank.

$\overline{\text{CSH2}}$: Chip-Select Half 2. This signal selects the second bank of memory. It has the same timing as $\overline{\text{EDS}}$. Setting this pin to a high-level general-purpose output disables the bank.

$\overline{\text{CSH3}}$: Chip-Select Half 3. This signal selects the third bank of memory. It has the same timing as $\overline{\text{EDS}}$. Setting this pin to a high-level general-purpose output disables the bank.

GLOSSARY/SYMBOLS, TERMS, AND DEFINITIONS

CSPF: Chip-Select Peripheral File. This signal has the same timing as $\overline{\text{EDS}}$, but it goes active only during access to external frames of the peripheral field (locations 10C0h – 10FFh).

D

data: Any information stored in or retrieved from a memory device.

debugger: A window-oriented software interface that helps the user to debug '370 programs running on an emulator, CDT370, or design kit.

dedicated-capture registers: An area in the PACT module dual-port RAM that stores the value of the default timer at the time of a specified edge on one of the PACT input-capture pins. Unlike the circular buffer, the location of the dedicated-capture register does not change.

default timer (also hardware timer): A 20-bit hardware counter in the PACT module that is incremented by the PACT prescaled clock

design kit: A low-cost tool that allows the user to analyze the hardware and software capabilities of the TMS370 family.

DIP: Dual In-line Package

dual-port RAM: An area in RAM that can be read from and written to by both the TMS370 CPU and the PACT module.

E

edge detection: A type of circuitry that senses an active pulse transition on a given timer input and provides appropriate output transitions to the rest of the module. The active transition can be configured to be low-to-high or high-to-low.

EDS: External Data Strobe. This signal goes low during external-memory operations. The rising edge of $\overline{\text{EDS}}$ validates the read-input data; the write data is available after the falling edge of $\overline{\text{EDS}}$.

EEPROM: *Electrically Erasable Programmable Read-Only Memory*. Memory that can be programmed and erased under direct program control.

EPROM: *Erasable Programmable Read-Only Memory*. Memory that can be programmed under direct program control.

Erase: Typically associated with EPROM and EEPROM. The procedure whereby programmed data is removed and the device returns to its unprogrammed state.

ESD: Electrostatic discharge

F

fully-static RAM: In a fully-static RAM, the periphery as well as the memory array is fully static. The periphery is therefore always active and ready to respond to input changes without the need of clocks. There is no precharge required for static periphery.

GLOSSARY/SYMBOLS, TERMS, AND DEFINITIONS

G

gang programmer: An interactive, menu-driven system that provides programming support for on-chip EEPROM or EPROM of the TMS370 microcontrollers in a production environment

H

HALT mode: An operating mode that reduces operating power by stopping the internal clock, which stops processing in all the modules. This is the lowest-power mode in which all register contents are preserved.

I

IDLE mode: An operating mode in which the CPU stops processing and waits for the next interrupt. It is not a low-power mode.

immediate operand: An operand whose actual constant value is specified in the instruction and placed after the opcode in the machine code

index: An 8-bit unsigned number added to a base address to give a final address

instruction: The basic unit of programming that causes the execution of one operation; consists of an opcode and operands, along with optional labels and comments

interrupt: A signal to the CPU that stops the flow of a program and forces the CPU to execute instructions at an address corresponding to the source of the interrupt. When the interrupt is finished, the CPU resumes execution at the point where it was interrupted.

isochronous: see **isosynchronous-communications mode**

isosynchronous-communications mode: An SCI mode in which data transmission is synchronized by a clock signal (SCICLK) common to both the sender and receiver. The format is identical to the asynchronous-communications mode and consists of a start bit, data bits, an optional parity bit, and a stop bit.

K

K: When used in the context of specifying a given number of bits of information, $1K = 2^{10} = 1024$ bits. Thus, $64K = 64 \times 1024 = 65\,536$ bits.

L

label: A symbol that begins in column 1 of a source statement and corresponds to the address of that statement.

linker: A software tool that combines object files to form an object module that can be allocated into system memory and executed by the devices

LOW ADDR/HI ADDR: External memory address bus. Output only. Port B is the low address, and Port C is the high address.

low-power mode: An operating mode that reduces operating power by reducing or stopping the activity of various modules. There are two low-power modes: HALT and STANDBY.

GLOSSARY/SYMBOLS, TERMS, AND DEFINITIONS

LSB: *Least significant bit*

LSbyte: *Least significant byte*

M

machine code: The actual bytes read by the CPU during an instruction execution; usually read by a programmer as hexadecimal bytes

mask-programmed read-only memory (Mask-ROM): A read-only memory in which the data content of each cell is determined during manufacture by the use of a mask, the data content thereafter being unalterable

MC pin: *Mode control pin.* The pin that determines the operating mode of the TMS370 device, depending on the voltage applied to the pin. Twelve volts on the MC pin after reset places the processor in the write-protection override (WPO) mode.

memory: A medium capable of storing information that can be retrieved.

memory map: A description of the addresses of the various sections and features of the TMS370 processor. The map depends on the operating mode.

microcomputer mode with external expansion: An operating mode in which the address, control, and data memory extend off-chip to access external memory or peripherals

microcomputer single-chip mode: An operating mode in which the device uses only on-chip memory

microcontroller programmer: An interactive, menu-driven system that provides a method of programming TMS370 family devices and EPROMs directly or through an XDS

microprocessor mode with internal-program memory: An operating mode in which the on-chip program memory is available to the processor

microprocessor mode without internal-program memory: An operating mode in which the on-chip program memory is not available to the processor. The processor must have external memory.

mini-SCI: The mini-UART function available in the PACT module.

mnemonic: A symbol that represents the opcode part of an assembly language instruction.

MSB: *Most significant bit*

MSbyte: *Most significant byte*

multiprocessor communications: An SCI format option that enables one processor to efficiently send blocks of data to other processors on the same serial link

N

nested interrupts: The ability of an interrupt to suspend the service routine of a prior interrupt. Nested interrupts are implemented in TMS370 devices by executing an interrupt-service routine that uses the EINT, EINTL, or EINTH instructions to set the global-interrupt-enable bits in the status register.

nonmaskable interrupt (NMI): An interrupt that causes the processor to execute the NMI routine. On TMS370 devices, INT1 can be configured as an NMI.

nonreturn to zero (NRZ) format: A communication format in which the inactive state is a logic state

nonvolatile memory: A memory in which the data content is maintained whether the power supply is connected or not

GLOSSARY/SYMBOLS, TERMS, AND DEFINITIONS

O

OCF: Opcode Fetch. Goes low at the beginning of a memory read operation that fetches the first byte of an instruction. It then resumes its high level at the end of the opcode fetch(es).

offset: A signed value that is added to the base operand to give the final address

opcode: *Operation code.* The first byte of the machine code that describes to the CPU the type of operation and combination of operands. Some TMS370 instructions use 16-bit opcodes.

operand: The part of an instruction that tells the programmer where the CPU will fetch or store data

one-time programmable (OTP) read-only memory: a read-only memory that, after being manufactured, can have the data content of each memory cell altered once. Also referred to as OTP.

Output Enable: A control input that, when true, permits data to appear at the memory output, and when false, causes the output to assume a high-impedance state. (See also chip select.)

P

PACT: *Programmable acquisition and control timer module.* A timer coprocessor module for the TMS370 microcontroller family.

PDIP: Plastic Dual In-Line Package

peripheral file (PF): The 128 or 256 bytes of memory, starting at 1000h, that contain the registers that control the on-board peripherals and system configuration

peripheral-file frames: A set of sixteen contiguous peripheral file registers, usually related by function

PLCC: Plastic Leaded Chip Carrier

PPM: *Pulse-position modulation.* A serial signal in which the information is contained in the frequency of a signal with a constant-pulse width. By using the timer-compare features, a TMS370 device can output a PPM signal with a constant duty cycle without any program intervention.

prescaler: A circuit that slows the rate of a clocking source to the counter. The timer 1 prescaler can slow the clocking source by a factor of 4, 16, 64, or 256.

privilege mode: A mode immediately following reset in which the program can alter the privileged registers and bits. Once the privilege mode is disabled, these registers cannot be changed before another reset. This mode does not affect the EEPROM or the watchdog registers.

program: Typically associated with EPROM and OTP memories, the procedure whereby logical 0s (or 1s) are stored into various desired locations in a previously erased device

program counter (PC): A CPU register that identifies the current statement in the program

prototyping device: A device used before mask-ROM devices are available that has identical functions, pinout, size, and timings to those of the actual device. Programmable memory such as EEPROM or EPROM is used in place of the masked ROM.

PSDIP: Plastic Shrink Dual In-Line Package

pulse accumulation: A timer 1 or timer 2 mode that keeps a cumulative count of SYSCLK pulses gated by the T1EVT or T2EVT signal

PWM: *Pulse-width modulation.* A serial signal in which the information is contained in the width of a pulse of a constant-frequency signal. By using the timer-compare features, a TMS370 device can output a PWM signal with a constant-duty cycle without any program intervention.

R

R/ \bar{W} : Read or Write operation. Goes high at the beginning of read operations and low during write operations. This line is active during both internal and external accesses.

RAM: *Random-access memory*

ratiometric conversion: An analog-to-digital conversion in which the conversion value is a ratio of the V_{REF} source to the analog input. As V_{REF} is increased, the input voltage needed to give a certain conversion value changes; however, all conversion values keep the same relationship to V_{REF} .

read: A memory operation whereby data is output from a desired address location

read-only memory (ROM): A memory in which the contents are not intended to be altered during normal operation. NOTE: Unless otherwise qualified, the term "read-only memory" implies that the contents are determined by its structure and are unalterable.

referred timer: The timer that a PACT command uses for time comparisons. This is the last timer defined in the PACT command/definition area before the command was encountered, or if no timer has been defined, it is the least significant 16 bits of the hardware timer.

register file (RF): The first 128 or 256 bytes of memory that can be accessed by the majority of the instructions

relative-addressing mode: An operating mode in which operands and code produce an absolute address at some distance from the current location

RESET pin: A pin that, when held low, starts hardware initialization and ensures an orderly software startup. If the MC pin is low when the RESET signal returns high, then the processor enters the microcomputer mode. If the MC pin is high when the RESET signal returns high, then it enters the microprocessor mode.

ROM security: Inhibits the reading of the ROM using any programmer

S

serial communications interface (SCI): Referred to as SCI1 or SCI2. SCI1 is a built-in serial interface that can be programmed to be asynchronous or isosynchronous. SCI2 is a built-in serial interface that can only be programmed to be asynchronous. Many timing, data format, and protocol factors are programmable and controlled by the SCI module in operation.

serial peripheral interface (SPI): A built-in serial interface that facilitates communication between networked master and slave CPUs. As in the SCI, the SPI is set up by software; from then on, the CPU takes no part in timing, data format, or protocol.

signed integer: A number system used to express positive and negative integers

SPI: *Serial Peripheral Interface module*

stack: The part of the register file used as last-in, first-out memory for temporary-variable storage. The stack is used during interrupts and calls to store the current program status. The area occupied by the stack is determined by the stack pointer and by the application program.

stack pointer (SP): An 8-bit CPU register that points to the last entry or top of the stack. The SP is incremented automatically before data is pushed onto the stack and decremented after data is popped from the stack.

standby RAM: Random-access memory which is powered through a separate power pin to protect the memory against power failures on the main power pin.

STANDBY mode: A power reduction mode in which the CPU stops processing, but the on-chip oscillator remains active. Timers remain active and can cause the CPU to exit the STANDBY mode.

GLOSSARY/SYMBOLS, TERMS, AND DEFINITIONS

static RAM (SRAM): A read/write random-access device within which information is stored as latched voltage levels. The memory cell is a static latch that retains data as long as power is applied to the memory array. No refresh is required. The type of periphery circuitry sub-categorizes static RAMs.

status register (ST): A CPU register that monitors the operation of the instructions and contains the global-interrupt-enable bits

symbolic debugging: The ability of a software tool to retain symbolic information so that it can be used by a debugging tool such as an XDS/22, a design kit, or a CDT370

symbol table: A portion of a COFF file that contains information about the symbols that are defined and used by the file

SYCLK: System Clock. This signal synchronizes external peripherals. It outputs one quarter of the crystal or external oscillator frequency.

T

T1: Timer 1 module contains a general-purpose timer and watchdog timer. Both timers allow program selection of input-clock source (real time, external event, or pulse accumulate) with multiple registers (input capture and compare) for special timer function control.

T2A: Timer 2A module is composed of a 16-bit resettable counter, 16-bit compare register with associated compare logic, a 16-bit capture register, and a 16-bit register that functions as a capture register in one mode and as a compare register in the other mode.

T2B: Timer 2B module is composed of a 16-bit resettable counter, 16-bit compare register with associated compare logic, a 16-bit capture register, and a 16-bit register that functions as a capture register in one mode and as a compare register in the other mode.

time slots: The internal cycles in which the PACT module can make a 32-bit access to the dual-port RAM. Each command or definition requires one, two, or three time slots. The number of time slots available is a function of the PACT prescaled clock and the frequency of access to the dual-port RAM by the CPU.

U

unsigned integer: A number system used to express positive integers

V

very-large-scale integration (VLSI): The description of an IC technology that is much more complex than large-scale integration (LSI) and involves a much higher equivalent gate count. At this time an exact definition including a minimum gate count has not been standardized by JEDEC or the IEEE.

virtual timer: An entry in the PACT command/definition area that creates an independent time base that is incremented by the PACT prescaled clock and cleared upon reaching a maximum value that is set by this definition.

volatile memory: A memory in which the data content is lost when the power supply is disconnected

GLOSSARY/SYMBOLS, TERMS, AND DEFINITIONS

W

WAIT pin: The pin that allows an external device to cause the processor to wait (holding the information on the expansion bus) for an indefinite number of clock cycles (one or more extra clockout cycles). When the wait line is released, the processor resynchronizes with the rising edge of the clockout signal (CLKOUT) after \overline{EDS} goes active and continues with the program.

wait states, automatic: Extra clock cycles inserted automatically on every external-memory access to accommodate peripherals or expansion memory with slower access time than the TMS370 processor. These wait states are governed by two control bits: PF AUTOWAIT (SCCR0.5) and AUTOWAIT DISABLE (SCCR1.4).

watchdog (WD) timer: A timer option that can be programmed to generate an interrupt when it times out. This function serves as a hardware monitor over the software to prevent a “lost” program and is available in both the timer 1 and PACT modules. If timer 1 does not need a watchdog, this timer can be used as a general-purpose timer.

write: A memory operation whereby data is written into a desired address location

Write Enable: A control signal that when true causes the memory to assume the write mode, and when false causes it to assume the read mode

write-protect override (WPO): The only mode in which a TMS370 device can modify the on-board EEPROM. The WPO mode is entered when external circuitry applies 12 V to the MC pin after the device has been reset into one of its normal operating modes.

X

XDS/22: A code-development tool that is external to the target system and provides direct control over the TMS370 processor that is on the target system

GLOSSARY/SYMBOLS, TERMS, AND DEFINITIONS

General Information	1
Quality and Reliability	2
Electrostatic Discharge Guidelines	3
Mechanical Data	4

Contents

	Page
Introduction to Quality and Reliability	2-3
Reliability Stress Tests	2-4

INTRODUCTION TO QUALITY AND RELIABILITY

introduction to quality and reliability

The quality and reliability of Texas Instruments (TI) microprocessor and microcontroller products, which include the TMS370 8-bit microcontrollers and the TMS320 digital signal processors, rely on the following:

- Feedback from customers
- Total manufacturing operation from front-end wafer fabrication to final shipping inspection
- Monitoring of product quality and reliability

The customer's perception of quality is the governing criterion for judging performance. This concept is the basis for TI Corporate Quality Policy, which is as follows:

"For every product or service we offer, we shall define the requirements that solve the customer's problems, and we shall conform to those requirements without exception."

Texas Instruments has developed a leadership reliability qualification system, based on years of experience with leading-edge memory technology and years of research into customer requirements. To achieve constant improvement, programs that support that system respond to customer input and internal information.

This section discusses the following major topic: reliability stress tests.

RELIABILITY STRESS TESTS

reliability stress tests

Accelerated stress tests are performed on new semiconductor products and process changes to qualify them and to ensure excellence in product reliability. The following test environments are typical:

- High-temperature operating life
- Storage life
- Temperature cycling
- Biased humidity
- Autoclave
- Electrostatic discharge
- Package integrity
- Electromigration
- Channel-hot electrons (performed on geometries of less than 2.0 μm)

Typical events or changes that require internal requalification of a product include the following:

- New die design, shrink, or layout
- Wafer process (baseline/control systems, flow, mask, chemicals, gases, dopants, passivation, or metal systems)
- Packaging assembly (baseline control systems or critical assembly equipment)
- Piece parts (such as lead frame, mold compound, mount material, bond wire, or lead finish)
- Manufacturing site

TI reliability control systems extend beyond qualification. Total reliability controls and management include product reliability monitoring as well as final product release controls. Metal oxide semiconductor (MOS) memories, utilizing high-density active elements, serve as the leading indicator in wafer-process integrity at TI MOS fabrication sites, enhancing all MOS-logic device yields and reliability. Monthly, TI places several thousand MOS devices on reliability tests to ensure and sustain built-in product excellence.

Table 1 lists the microprocessor and microcontroller reliability tests, the duration of the tests, and the size of the samples. Table 2 contains definitions and descriptions of the terms used in these tests.

Table 1. Microprocessor and Microcontroller Tests

TEST	DURATION	SAMPLE SIZE	
		PLASTIC	CERAMIC
Operating life, 125°C, 5.0 V	1000 hrs	129	129
Storage life, 150°C	1000 hrs	45 [†]	45
Biased humidity, 85°C/85% RH, 5 V	1000 hrs	77	–
Autoclave, 121°C, 1 ATM	240 hrs	45	–
Temperature cycle, –65°C to 150°C	1000 cyc [‡]	77	77
Temperature cycle, 0°C to 125° C	3000 cyc	77	77
Thermal shock, –65°C to 150° C	200 cyc	77	77
Electrostatic discharge, ±2 kV		15	15
Latch-up (CMOS devices only)		5	5
Mechanical sequence		–	22
Thermal sequence		–	22
Thermal/mechanical sequence		–	22
Particle Impact Noise Detection (PIND)		–	45
Internal water vapor		–	3
Solderability		22	22
Solder heat		22	22
Resistance to solvents		15	15
Lead integrity		15	15
Lead pull		22	–
Lead finish adhesion		15	15
Salt atmosphere		15	15
Flammability (UL94-V0)		3	–
Thermal impedance		5	5

[†] If junction temperature does not exceed plasticity of package

[‡] For severe environments; reduced cycles for office environments

RELIABILITY STRESS TESTS

Table 2. Definitions of Microprocessor Testing Terms

TERM	DEFINITION/DESCRIPTION	REFERENCES
Average Outgoing Quality (AOQ)	Amount of defective product in a population, usually expressed in terms of parts per million (PPM)	
Failure in Time (FIT)	Estimated field failure rate in number of failures per billion power-on device hours; 1000 FITS equal 0.1% failures per 1000 device hours.	
Operating Life	Device dynamically exercised at a high ambient temperature (usually 125°C) to simulate field usage that would expose the device to a much lower ambient temperature (such as 55°C). Using a derived high temperature, a 55°C ambient failure rate can be calculated.	
Storage Life	Device exposed to 150°C unbiased condition. Bond integrity is stressed in this environment.	
Biased Humidity	Moisture and bias used to accelerate corrosion-type failures in plastic packages. Conditions include 85°C ambient temperature with 85% relative humidity (RH). Typical bias voltage is 5 V and is grounded on alternating pins.	
Autoclave (Pressure Cooker)	Plastic-packaged devices exposed to moisture at 121°C using a pressure of one atmosphere above normal pressure. The pressure forces moisture permeation of the package and accelerates corrosion mechanisms (if present) on the device. External package contaminants can also be activated and caused to generate inter-pin current leakage paths.	
Temperature Cycle	Device exposed to severe temperature extremes in an alternating fashion (–65°C for 15 minutes and 150°C for 15 minutes per cycle) for at least 1000 cycles. Package strength, bond quality, and consistency of assembly process are tested in this environment.	
Electrostatic Discharge (ESD)	Device exposed to electrostatic discharge pulses. Calibration is according to MIL STD 883C, method 3015.6. Devices are stressed to determine failure threshold of the design.	

RELIABILITY STRESS TESTS

Table 2. Definitions of Microprocessor Testing Terms (Continued)

TERM	DEFINITION/DESCRIPTION	REFERENCES
Thermal Shock	Test similar to the temperature cycle test, but involving a liquid-to-liquid transfer.	MIL-STD-883C, Method 1011
Particle Impact Noise Detection (PIND)	A nondestructive test to detect loose particles inside a device cavity.	
Mechanical Sequence	Fine and gross leak Mechanical shock PIND (optional) Vibration, variable frequency Constant acceleration Fine and gross leak Electrical test	MIL-STD-883C, Method 1014 MIL-STD-883C, Method 2002, 1500 g, 0.5 ms, Condition B MIL-STD-883C, Method 2020 MIL-STD-883C, Method 2007, 20g, Condition A MIL-STD-883C, Method 2001 MIL-STD-883C, Method 1014 To data sheet limits
Thermal Sequence	Fine and gross leak Solder heat (optional) Temperature cycle (10 cycles minimum) Thermal shock (10 cycles minimum) Moisture resistance Fine and gross leak Electrical test	MIL-STD-883C, Method 1014 MIL-STD-750C, Method 1014 MIL-STD-883C, Method 1010, -65 to +150°C, Condition C MIL-STD-883C, Method 1011, -55 to +125°C, Condition B MIL-STD-883C, Method 1004 MIL-STD-883C, Method 1014 To data sheet limits
Thermal/Mechanical Sequence	Fine and gross leak Temperature cycle (10 cycles minimum) Constant acceleration Fine and gross leak Electrical test Electrostatic discharge Solderability Solder heat Salt atmosphere Lead pull Lead integrity Electromigration Resistance to solvents	MIL-STD-883C, Method 1014 MIL-STD-883C, Method 1010, -65 to +150°C, Condition C MIL-STD-883C, Method 2001, 30 kg, Y1 Plane MIL-STD-883C, Method 1014 To data sheet limits MIL-STD-883C, Method 3015 MIL-STD-883C, Method 2033 MIL-STD-750C, Method 2031, 10 sec MIL-STD-883C, Method 1009, Condition A, 24 hrs min MIL-STD-883C, Method 2004, Condition A MIL-STD-883C, Method 2004, Condition B1 Accelerated stress testing of conductor patterns to ensure acceptable lifetime of power-on operation MIL-STD-883C, Method 2015

Texas Instruments reserves the right to make changes in semiconductor test limits, procedures, or processes without notice. Unless prior arrangements for notification have been made, TI advises all customers to verify current test and manufacturing conditions prior to relying on published data.

RELIABILITY STRESS TESTS

General Information	1
Quality and Reliability	2
Electrostatic Discharge Guidelines	3
Mechanical Data	4

Contents

	Page
Scope	3-3
Definitions	3-3
Device Sensitivity Per Test Circuit of Method 3015, MIL-STD-883C	3-3
Applicable Reference Documents	3-4
Facilities for Static-Free Workstation	3-4
Usage of Antistatic Solution in Areas to Control the Generation of Static Charges	3-5
ESD Labels and Signs in Work Areas	3-6
Relative Humidity Control	3-6
Preparation for Working at Static-Free Workstation	3-6
General Handling Procedures and Requirements (for ESDS Devices and Assemblies)	3-7
Packaging Requirements	3-8
Specific Handling Procedures for Static-Sensitive Items	3-8
Customer-Returned-Item Handling Procedure	3-10
Quality Control Provision	3-10

scope

This guideline establishes the requirements for methods and materials used to protect electronic parts, devices, and assemblies (items) that are susceptible to damage or degradation from electrostatic discharge (ESD). The electrostatic charges referred to in this specification are generated and stored on surfaces of ordinary plastics, most common textile garments, ungrounded person's bodies, and many other commonly unnoticed static generators. The passage of these charges through an electrostatic-sensitive part can result in catastrophic failure or performance degradation of the part.

The part types for which these requirements are applicable include, but are not limited to the following:

- All metal-oxide semiconductor (MOS) devices; e.g., CMOS, PMOS, etc.
- Junction field-effect transistors (JFET)
- Bipolar digital and linear circuits
- Op-amps, monolithic microcircuits with MOS compensating networks, on-board MOS capacitors, or other MOS elements
- Hybrid microcircuits and assemblies containing any of the types of devices listed
- Printed circuit boards and other types of assembly containing static-sensitive devices
- Thin-film passive devices

definitions

- Electrostatic discharge (ESD): A transfer of electrostatic charges between bodies at different electrostatic potentials caused by direct contact or electrostatic field induction.
- Conductive material: Material having a surface resistivity of $10^5 \Omega/\text{square}$ maximum.
- Static dissipative material: Material having a surface resistivity between 10^5 and $10^9 \Omega/\text{square}$.
- Antistatic material: Material having a surface resistivity between 10^9 and $10^{14} \Omega/\text{square}$.
- Surface resistivity: An inverse measure of the conductivity of a material and is the resistance of unit length and unit width of a surface. Note: Surface resistivity of a material is numerically equal to the surface resistance between two electrodes forming opposite sides of a square. The size of the square is immaterial. Surface resistivity applies to both surface- and volume-conductive materials and has the dimension of Ω/square .
- Volume resistivity: Also referred to as bulk resistivity, it is normally determined by measuring the resistance (R) of a square of material (surface resistivity) and multiplying this value by the thickness (T).
- Ionizer: A blower that generates positive and negative ions, either by electrostatic means or from a radioactive energy source in an airstream and distributes a layer of low-velocity ionized air over a work area to neutralize static charges.
- Close proximity: For the purpose of this guideline, six inches or less.

device sensitivity per test circuit of Method 3015, MIL-STD-883C

- Devices are categorized according to their susceptibility to damage resulting from electrostatic discharges (ESD).

Category	ESD Sensitivity
Class 1	0 V – 1999 V
Class 2	2000 V – 3999 V
Class 3	4000 V and above

- At TI, devices are to be protected from ESD damage from receipt at incoming inspection through assembly, test, and shipment of completed equipment.
-

APPLICABLE REFERENCE DOCUMENTS

applicable reference documents

The following reference documents (of latest issue) can provide additional information on ESD controls.

- MIL-M-38510 Microcircuits, General Specification
- MIL-STD-883 Test Methods and Procedures for Microelectronics
- MIL-STD-19491 Semiconductor Devices, Packaging of
- MIL-M-55565 Microcircuits, Packaging of
- DOD-HDBK-263 Electrostatic Discharge Control Handbook for Protection
- DOD-STD-1686 Electrostatic Discharge Control Program
- NAVSEA SE 003-11-TRN-010 Electrostatic Discharge Training Manual
- JEDEC Standard Publication 108

facilities for static-free workstation

The minimum acceptable static-free workstation consists of a work surface covered with static dissipative material attached to ground through a $1\text{ M}\Omega \pm 10\%$ resistor, an attached grounding wrist strap with integral $1\text{ M}\Omega \pm 10\%$ resistor for each operator, and air ionizer(s) of sufficient capacity for each operator. The wrist strap must be connected to the static dissipative material. Ground must utilize the standard building earth ground; refer to Figure 1. Conductive floor tile/carpet along with conductive shoes can be used in lieu of the conductive wrist straps for non-seated personnel. The Site Safety Engineer must review and approve all electrical connections at the static-free workstation prior to its implementation.

Air ionizers must be positioned so that the devices at the static-free workstations are within a 4-foot arc measured by a vertical line from the face of the ionizer and 45 degrees on each side of this line.

General grounding requirements are to be in accordance with Table 1.

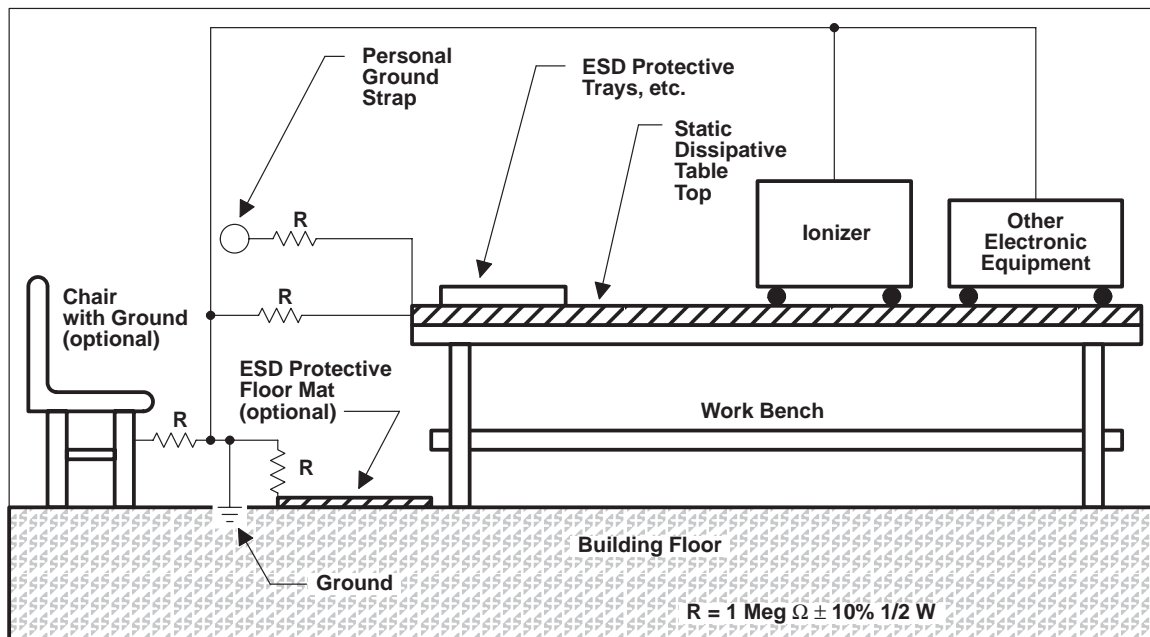

All electrical equipment sitting on the conductive table top must be hard grounded but must be isolated from the static dissipative work surface.

NOTE A: Earth ground is not computer ground or RF ground or any other limited-type ground.

Figure 1. Static-Free Workstation

USAGE OF ANTI-STATIC SOLUTION IN AREAS TO CONTROL THE GENERATION OF STATIC CHARGES

facilities for static-free workstation (continued)

Table 1. General Grounding Requirements

	TREATED WITH ANTI-STATIC SOLUTION OR MADE OF CONDUCTIVE MATERIAL	GROUNDED TO COMMON POINT	STATIC DISSIPATIVE MATERIAL
Handling equipment/handtools	X		X
Metal parts of fixtures and tools/storage racks		X	
Handling trays/tubes	X		X
Soldering irons/baths		X	
Table tops/floor mats	X	X	X
Personnel		X [†]	

[†] Using a wrist strap with 1 MΩ ± 10% resistor

usage of antistatic solution in areas to control the generation of static charges

The use of antistatic chemicals (antistats) may be a supplemental part of an overall organized ESD program. Any antistatic chemical application must be considered as a means to reduce or eliminate static charge generation on nonconductive materials in the manufacturing or storage areas.

The application of any antistatic chemical in a clean room of class 10,000 or less cannot be permitted. Accordingly, any user of antistatic solutions must consider the following precautions:

- Antistatic spray or solutions in any form cannot be applied to energized electrical parts, assemblies, panels, or equipment.
- Antistatic chemical applications cannot be performed in any area when bare chips, raw parts, packages, and/or personnel are exposed to spray mists and evaporation vapors.

The need for initial application and frequency of reapplication can be established only through routing electrostatic voltage measurements using an electrostatic voltmeter. The following durability schedule is a reasonable expectation.

- Soft surfaces (carpet, fabric seats, foam padding, etc.): each six months or after cleaning, by spraying.
- Hard abused surfaces (floor, table tops, tools, etc.): each week (or day for heavy use) and after cleaning, by wiping or mopping.
- Hard unabused surfaces (cabinets, walls, fixtures, etc.): each six months or annually and after cleaning, by wiping or spraying.
- Company-furnished and maintained clothing and smocks: after each cleaning, by spraying or adding antistatic concentrate to final rinse water when cleaned.

The use of antistatic chemicals, their application, and compliance with all appropriate specifications, precautions, and requirements must be the responsibility of the area supervisor where antistatic chemicals are used.

ESD LABELS AND SIGNS IN WORK AREAS

ESD labels and signs in work areas

ESD caution signs at workstations and labels on static-sensitive parts and containers must be consistent in color, symbols class, voltage-sensitivity identification, and appropriate instructions. Signs must be posted at all workstations performing operations with static-sensitive items. These signs must contain the following information or its equivalent.

CAUTION

STATIC CAN DAMAGE COMPONENTS

Do not handle ESD-sensitive items unless grounding wrist strap is properly worn and grounded. Do not let clothing or plain plastic materials contact or come in close proximity to ESD-sensitive items.

Labels must be affixed to all containers containing static-sensitive items at a place readily visible and proper for the intended purpose. Additionally, labels must be consistently placed on containers and packages at a standard location to eliminate mishandling. Use only QC-accepted and approved signs and labels to identify static-sensitive products and work areas. The use of ESD signs and labels and their information content must be the responsibility of the area supervisor to ensure consistency and compatibility throughout the static-sensitive routing.

relative humidity control

Since relative humidity has a significant impact on the generation of static electricity, when possible, the work area must be maintained within the 40%–60% relative humidity range.

preparation for working at static-free workstation

A workstation with a static dissipative work surface connected to ground through a $1\text{ M}\Omega \pm 10\%$ resistor, a grounding wrist strap with the ground wire connected to the conductive work surface, and an ionizer constitute a static-free workstation (Figure 1). An operator is grounded properly when the wrist strap is in snug (no slack) contact with the bare skin, usually positioned on the left wrist for a right-handed operator. The wrist strap must be worn the entire time an operator is at a static-free workstation. The operator must touch the grounded bench top first before handling static-sensitive items. This precaution must be observed in addition to wearing the grounding wrist strap. If possible, the operator must avoid touching leads or contacts even though he or she is grounded.

CAUTION

Personnel must never be attached to a static-free workstation without a properly worn and grounded wrist strap (the presence of the $1\text{ M}\Omega \pm 10\%$ series resistor in the ground wire).

An operator's clothing must never make contact or come in close proximity with static-sensitive items. Operators must be especially careful to prevent any static-sensitive items (being handled) from touching their clothing. Long sleeves must be rolled up or covered with antistatic sleeve protector banded to the bare wrist, which must "cage" the sleeve at least as far up as the elbow. Only antistatic finger cots can be used when handling static-sensitive items.

GENERAL HANDLING PROCEDURES AND REQUIREMENTS (FOR ESDS DEVICES AND ASSEMBLIES)

preparation for working at static-free workstation (continued)

Any improperly prepared person, while at or near the work station, must not touch or come in close proximity with any static-sensitive item. It is the responsibility of the operator and the area supervisor to ensure that the static-free work area is clear of unnecessary static hazards, including such personal items as plastic-coated cups or wrappers, plastic cosmetic bottles or boxes, combs, tissue boxes, cigarette packages, and vinyl or plastic purses. All work-related items, including information sheets, fluid containers, tools, and part carriers must be approved for use at the static-free workstation.

general handling procedures and requirements (for ESDS devices and assemblies)

- All static-sensitive items must be received in an antistatic/conductive container and must not be removed from the container except at the static-free workstation. All protective folders or envelopes holding documentation (lot travelers, etc.) must be made of nonstatic-generating material.
- Each packing (outermost) container and package (internal or intermediate) must have a bright yellow warning label attached, stating the following information or equivalent:



The warning label must be legible and easily readable to normal vision at a distance of three feet.

- Static-sensitive items are to remain in their protective containers except when actually in use at the static-free station.
- Before removing an item from its protective container, the operator must place the container on the conductive grounded bench top, make sure the wrist strap fits snugly around the wrist and is properly plugged into the ground receptacle, and then touch their hands to the conductive bench top.
- All operations on the items must be performed with the items in contact with the grounded bench top as much as possible. Conductive magazine are not allowed to touch the hard-grounded test gear on bench top.
- Ordinary plastic solder-suckers and other plastic assembly aids must not be used.
- In cases where it is impossible or impractical to ground the operator with a wrist strap, a conductive shoe strap can be used along with conductive tile/mats.
- When the operator moves from any other place to the static-free workstation, the start-up procedure must be the same as in Preparation for Working at Static-Free Workstation.
- The ionizer must be in operation prior to presenting any static-sensitive items to the static-free workstation, and must be in operation during the entire time period when the items are at the workstation.
- "Plastic snow" polystyrene foam, "peanuts," or other high-dielectric materials must never come in contact with, or be used around, electrostatic-sensitive items, unless they have been treated with an antistat (as evidenced by pink color and generation of less than ± 100 volts).
- Static-sensitive items must not be transported or stored in trays, tote boxes, vials, or similar containers made of untreated plastic material unless items are protectively packaged in conductive material.

PACKAGING REQUIREMENTS

packaging requirements

Packaging of static-sensitive items is to be in accordance with its category (see Device Sensitivity). The use of tape and plain plastic bags is prohibited. All outer and inner containers are to be marked as outlined in General Handling Procedures and Requirements. Conductive magazines/boxes can be used in lieu of conductive bags.

specific handling procedures for static-sensitive items

stockroom operations

- Containers of static-sensitive items are not to be accepted into stock unless adequately identified as containing static-sensitive items.
- Items may be removed from the protective container (magazine/bag, etc.) for the purpose of subdividing for order issue only by a properly grounded operator at an approved static-free workstation as defined in the Facilities for and Preparation for Working at Static-Free Workstation.
- All subdivided lots must be repackaged carefully in protective containers (magazine/bag, etc.) prior to removal from the static-free workstation and labeled to indicate that the package(s) contain static-sensitive items. If it is suspected that a static-sensitive item is not protected adequately, the item must not be transferred to another container; it must be returned to the originator for disposition unless the originator is a customer. In that case, the QC engineer must contact the customer and negotiate an appropriate disposition.
- It is the responsibility of the stockroom supervisor to ensure that all personnel assigned to this operation are familiar with the handling procedures as outlined in this specification. A copy of this specification is to be posted in the vicinity of the static-free workstation(s) so that it is accessible to the operators. Stock handlers and all others who might have occasion to move stock are to be instructed to avoid direct contact with unprotected static-sensitive items.

module and subassembly operations

- Static-sensitive items are not to be received from a stockroom, kitting, or machine insertion area unless received in approved static-protective packaging and properly labeled to indicate that the contents are static-sensitive.
- All single station, progressive-line manual-assembly operators, and visual inspectors prior to wave soldering operations are to be grounded properly with a grounding wrist strap when handling static-sensitive items.
- Progressive lines used as single stations where operators work on a mix of boards, both static-sensitive and nonstatic-sensitive, require that all operators working on the line be properly grounded. This is necessary to accommodate the sliding of static-sensitive boards along the assembly bench or across positions not engaged in the assembly of this type board.
- It is the responsibility of the area supervisor to ensure that all personnel handling static-sensitive items are familiar with this procedure and fully aware of the damage or degradation of these units in the event of noncompliance. A periodic inspection must be made using an electrostatic voltmeter to ensure that the static-free workstations are in the proper working order and to ensure that operators are wearing grounding wrist straps properly (snugly and in contact with bare skin).

SPECIFIC HANDLING PROCEDURES FOR STATIC-SENSITIVE ITEMS

specific handling procedures for static-sensitive items (continued)

soldering and lead-forming operations

- All soldering machines, conveyors, cleaning machines, and equipment must be grounded electrically to ensure that they are at the same ground potential as the grounded operators working on their stations. No machine surfaces exposed to static-sensitive items are to be above ground potential.
- All processing equipment must be grounded, including all loading and unloading stations, that is, the stations before and after each piece of processing equipment.
- All nonmetallic, static-generating components in the handling systems must be treated to ensure protection from static.
- All workstations must be identified by posting signs as outlined in ESD Labels and Signs in Work Areas.
- Operators are to be properly grounded with a grounding wrist strap during handling, loading, unloading, inspection, rework, or proximity to static-sensitive items.
- Unloading-operators working at a grounded station must place static-sensitive items into approved static-protective bags or containers.
- All manual soldering, repair, and touch-up workstations on the solder line are to be static protected. Operators are to wear grounding wrist straps when working on static-sensitive items. Only grounded-tip soldering/desoldering irons are allowed when working on static-sensitive items.
- It is the responsibility of the area supervisor to ensure that all personnel handling static-sensitive items are familiar with this procedure and fully aware of the damage or degradation of these units in the event of noncompliance. A periodic inspection must be made using an electrostatic voltmeter to ensure that the static-free workstations are in proper working order and to ensure that the operators are wearing grounding wrist straps properly (snugly and in contact with bare skin).

electrical testing operations

- All electrical test stations must be static-protected. Operators must be grounded properly when working on these items.
- Reused antistatic magazines must be monitored for maintenance of antistatic characteristics.
- Devices must be in an antistatic/conductive environment except at the moment when actually under test.
- Devices must not be inserted into or removed from circuits or tester with the power on or with signals applied to inputs to prevent transient voltages from causing permanent damage.
- All unused input leads must be biased if possible.
- Device or module repairs must be performed at static-free workstations with the operator attached to a grounding wrist strap. Grounded-tip soldering irons must be used when working on static-sensitive items.
- Static-sensitive items must be handled through all electrical inspections in static protective containers. Removal of the items from the protective containers must be done at a static-free workstation as discussed in Preparation for Working at a Static-Free Workstation. The units must be returned to the containers before leaving the station.

CUSTOMER-RETURNED-ITEM HANDLING PROCEDURE

specific handling procedures for static-sensitive items (continued)

- All such items must be shipped with an ESD warning label affixed as shown under the General Handling Procedures and Requirements (for ESD sensitive devices and assemblies).
- It is the responsibility of the area supervisor to ensure that all personnel handling static-sensitive items are familiar with this procedure and fully aware of the damage or possible degradation of these units in the event of noncompliance. A periodic inspection must be made using an electrostatic voltmeter to ensure that the static-free workstations are in proper working order and to ensure that operators are wearing grounding straps properly (snugly and in contact with bare skin).

packing operations

- Static-sensitive items are not to be accepted into the packing area unless they are contained in a static-protected bag or conductive container.
- A static-sensitive item delivered to the packer within an approved container or bag and found to be in order regarding identification must be packed in the standard shipping carton or other regular packaging material. Containers are to be labeled in accordance with General Handling Procedures and Requirements.
- Any void-fillers must be made of an approved antistatic material.

burn-in operations

- Burn-in board loading and unloading of static-sensitive items must be done at a static-free workstation.
- Shorting clips/shorted connectors must be installed on the board plug-in tab prior to loading any units into the board sockets. The clip/connectors must be taken off just prior to plugging the board into the oven connector. The clip/connector must be installed immediately upon removal of the board from the oven connector. Installation and removal of the clip/connector must be done by a properly grounded operator.
- All automatic or semi-automatic loading and unloading equipment must be properly electrically grounded.
- It is the responsibility of the area supervisor to ensure that all personnel handling static-sensitive items are familiar with this procedure and fully aware of the damage or possible degradation of these units in the event of noncompliance. A periodic inspection must be made using an electrostatic voltmeter to ensure that the static-free workstations are in proper working order and to ensure that operators are wearing grounding straps properly (snugly and in contact with bare skin).

customer-returned-item handling procedure

Receipt of ESD sensitive-labeled items is to be done at a static-free workstation and handled in accordance with applicable sections within this guideline.

quality control provision

sampling

Each manufacturing, stockroom, and testing operation handling ESD sensitive devices is audited a minimum of once each quarter for compliance with all terms of this specification by the responsible process control or QRA organization. Ground continuity and the presence of uncontrolled static voltages are considered critical and must be checked more frequently as specified below.

ground continuity (minimum of once a week)

Ground connections (grounding wrist strap, ground wires on cords, etc.) must be checked for electrical continuity. The presence of a $1\text{ M}\Omega \pm 10\%$ resistor in the ground connections between both the operator wrist straps to the work surface and the work surface to ground connector must be verified.

grounded conditions (minimum of once a week)

A visual inspection must be made to determine full compliance with this specification at static-free workstations during handling of static-sensitive items, including operator being grounded as required, static-sensitive items not being handled in unprotected or unauthorized areas, and no static-generating materials at the grounded workstation.

sleeve protectors (minimum of once a week)

A visual check must be made to determine that each operator wearing loose-fitting or long-sleeved clothing either has sleeves properly rolled or covered with sleeve protectors and is properly grounded with a wrist strap to the bare skin.

static voltage levels (minimum of once a week)

In addition to the visual inspections, a sample inspection using an electrostatic voltmeter to check for uncontrolled electrostatic voltages at or near electrostatic-controlled workstations.

conductive floor tiles (minimum of once a month)

Conductive floors must have a resistance of not less than 100 k Ω from any point on the tile to earth ground. Also, resistance from any point-to-point on the tile floor three (3) feet apart must be not less than 100 k Ω . The test methods to be used are ASTM-F-150-72 and NFPA 99.

records

Written records must be kept of all ESD QC audits.

training

Training is applicable for all areas where individuals come in contact with ESD-sensitive devices. It is the responsibility of each area supervisor to make sure that his/her people receive ESD training initially and every 12 months thereafter to maintain proficiency. Training may include static fundamentals, a review of applicable parts of this specification guideline, and actual applications in the work area.

QUALITY CONTROL PROVISION

General Information	1
Quality and Reliability	2
Electrostatic Discharge Guidelines	3
Mechanical Data	4

Contents

	Page
Mechanical Data	4-3
FN 28-, 44-, and 68-Pin Plastic Leaded Chip Carrier (PLCC)	4-4
FZ 28-, 44-, and 68-Pin Ceramic Leaded Chip Carrier (CLCC)	4-5
JD 28- and 40-Pin Ceramic Dual-In-Line Package (CDIP)	4-6
N 28- and 40-Pin Plastic Dual-In-Line Package (PDIP)	4-7
JC 40-Pin Ceramic Shrink Dual-In-Line Package (CSDIP)	4-8
NJ 40-Pin Plastic Shrink Dual-In-Line Package (PSDIP)	4-9
JN 64-Pin Ceramic Shrink Dual-In-Line Package (CSDIP)	4-10
NM 64-Pin Plastic Shrink Dual-In-Line Package (PSDIP)	4-11

mechanical data

Table 1 is designed to aid the user when referencing a device family to the mechanical data section. The table shows a cross-reference of the device family to the TMS370 generic package names and the associated mechanical drawing(s) by drawing number and name.

Table 1. TMS370 Family Package Type and Mechanical Cross-Reference

PACAKGE TYPE (mil pin spacing)	TMS370 GENERIC NAME	PACAKGE TYPE NUMBER AND MECHANICAL NAME	FAMILY MEMBERS†
FN – 28 pin (50-mil pin spacing)	PLASTIC LEADED CHIP CARRIER (PLCC)	FN(S-PQCC-J**) PLASTIC J-LEADED CHIP CARRIER	TMS370Cx0x, TMS370Cx1x, and TMS370CxCx
FN – 44 pin (50-mil pin spacing)	PLASTIC LEADED CHIP CARRIER (PLCC)	FN(S-PQCC-J**) PLASTIC J-LEADED CHIP CARRIER	TMS370Cx2x, TMS370Cx32, TMS370Cx36, TMS370Cx4x, TMS370Cx8x, and TMS370Cx9x
FN – 68 pin (50-mil pin spacing)	PLASTIC LEADED CHIP CARRIER (PLCC)	FN(S-PQCC-J**) PLASTIC J-LEADED CHIP CARRIER	TMS370Cx5x, TMS370Cx6x, TMS370Cx7x, and TMS370CxBx
FZ – 28 pin (50-mil pin spacing)	CERAMIC LEADED CHIP CARRIER (CLCC)	FZ(S-CQCC-J**) J-LEADED CERAMIC CHIP CARRIER	SE370Cx0x, SE370Cx1x, and SE370CxCx
FZ – 44 pin (50-mil pin spacing)	CERAMIC LEADED CHIP CARRIER (CLCC)	FZ(S-CQCC-J**) J-LEADED CERAMIC CHIP CARRIER	SE370Cx2x, SE370Cx32, SE370Cx36, SE370Cx4x, SE370Cx8x, and SE370Cx9x
FZ – 68 pin (50-mil pin spacing)	CERAMIC LEADED CHIP CARRIER (CLCC)	FZ(S-CQCC-J**) J-LEADED CERAMIC CHIP CARRIER	SE370Cx5x, SE370Cx6x, and SE370Cx7x
JD – 28 pin (100-mil pin spacing)	CERAMIC DUAL-IN-LINE PACKAGE (CDIP)	JD(R-CDIP-T**) CERAMIC SIDE-BRAZE DUAL-IN-LINE PACKAGE	SE370Cx1x and SE370CxCx
JD – 40 pin (100-mil pin spacing)	CERAMIC DUAL-IN-LINE PACKAGE (CDIP)	JD(R-CDIP-T**) CERAMIC SIDE-BRAZE DUAL-IN-LINE PACKAGE	SE370Cx2x and SE370Cx4x
N – 28 pin (100-mil pin spacing)	PLASTIC DUAL-IN-LINE PACKAGE (PDIP)	N(R-PDIP-T**) PLASTIC DUAL-IN-LINE PACKAGE	TMS370Cx1x and TMS370CxCx
N – 40 pin (100-mil pin spacing)	PLASTIC DUAL-IN-LINE PACKAGE (PDIP)	N(R-PDIP-T**) PLASTIC DUAL-IN-LINE PACKAGE	TMS370Cx2x, TMS370Cx4x, TMS370Cx8x, and TMS370CxAx
JC – 40 pin (70-mil pin spacing)	CERAMIC SHRINK DUAL-IN-LINE PACKAGE (CSDIP)	JC(R-CDIP-T40) CERAMIC SIDE-BRAZE DUAL-IN-LINE PACKAGE	SE370Cx2x, SE370Cx4x, and SE370Cx9x
NJ – 40 pin (70-mil pin spacing)‡	PLASTIC SHRINK DUAL-IN-LINE PACKAGE (PSDIP)	NJ(R-PDIP-T**) PLASTIC SHRINK DUAL-IN-LINE PACKAGE	TMS370Cx2x, TMS370Cx4x, and TMS370Cx9x
JN – 64 pin (70-mil pin spacing)	CERAMIC SHRINK DUAL-IN-LINE PACKAGE (CSDIP)	JN(R-CDIP-T64) CERAMIC DUAL-IN-LINE PACKAGE	SE370Cx5x and SE370Cx7x
NM – 64 pin (70-mil pin spacing)	PLASTIC SHRINK DUAL-IN-LINE PACKAGE (PSDIP)	NM(R-PDIP-T64) PLASTIC SHRINK DUAL-IN-LINE PACKAGE	TMS370Cx5x, TMS370Cx7x, and TMS370CxBx

† TMS370Cxxx refers to ROM and OTP devices; SE370Cxxx refers to UV-EPROM devices

‡ NJ formerly known as N2; the mechanical drawing of the NJ is identical to the N2 package and did not need to be requalified.

MECHANICAL DATA

FN 28-, 44-, and 68-pin plastic leaded chip carrier (PLCC)

FN (S-PQCC-J**)

20 PIN SHOWN

PLASTIC J-LEADED CHIP CARRIER

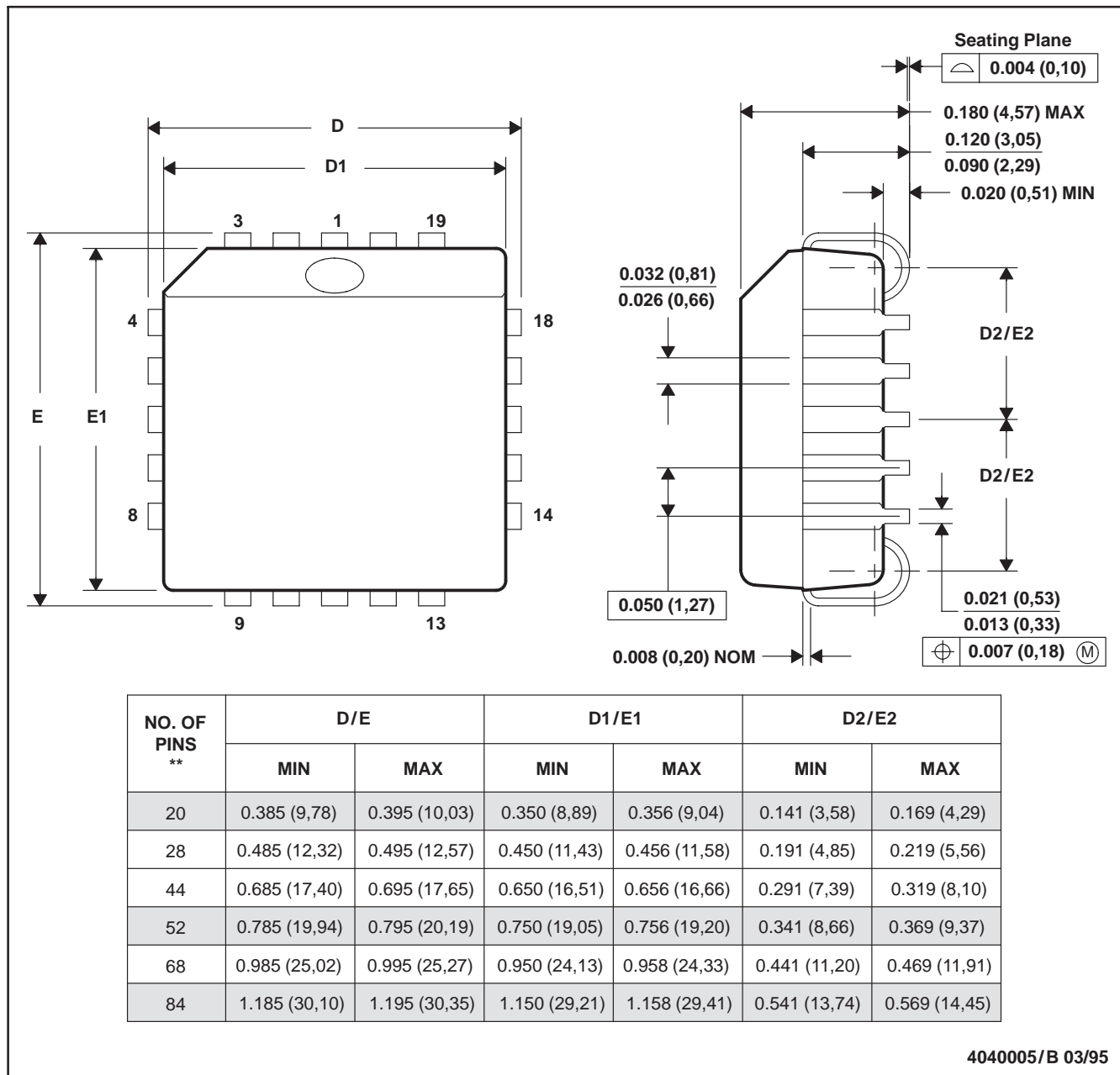

- NOTES: A. All linear dimensions are in inches (millimeters).
 B. This drawing is subject to change without notice.
 C. Falls within JEDEC MS-018

MECHANICAL DATA

FZ 28-, 44-, and 68-pin ceramic leaded chip carrier (CLCC)

FZ (S-CQCC-J**)

J-LEADED CERAMIC CHIP CARRIER

28 LEAD SHOWN

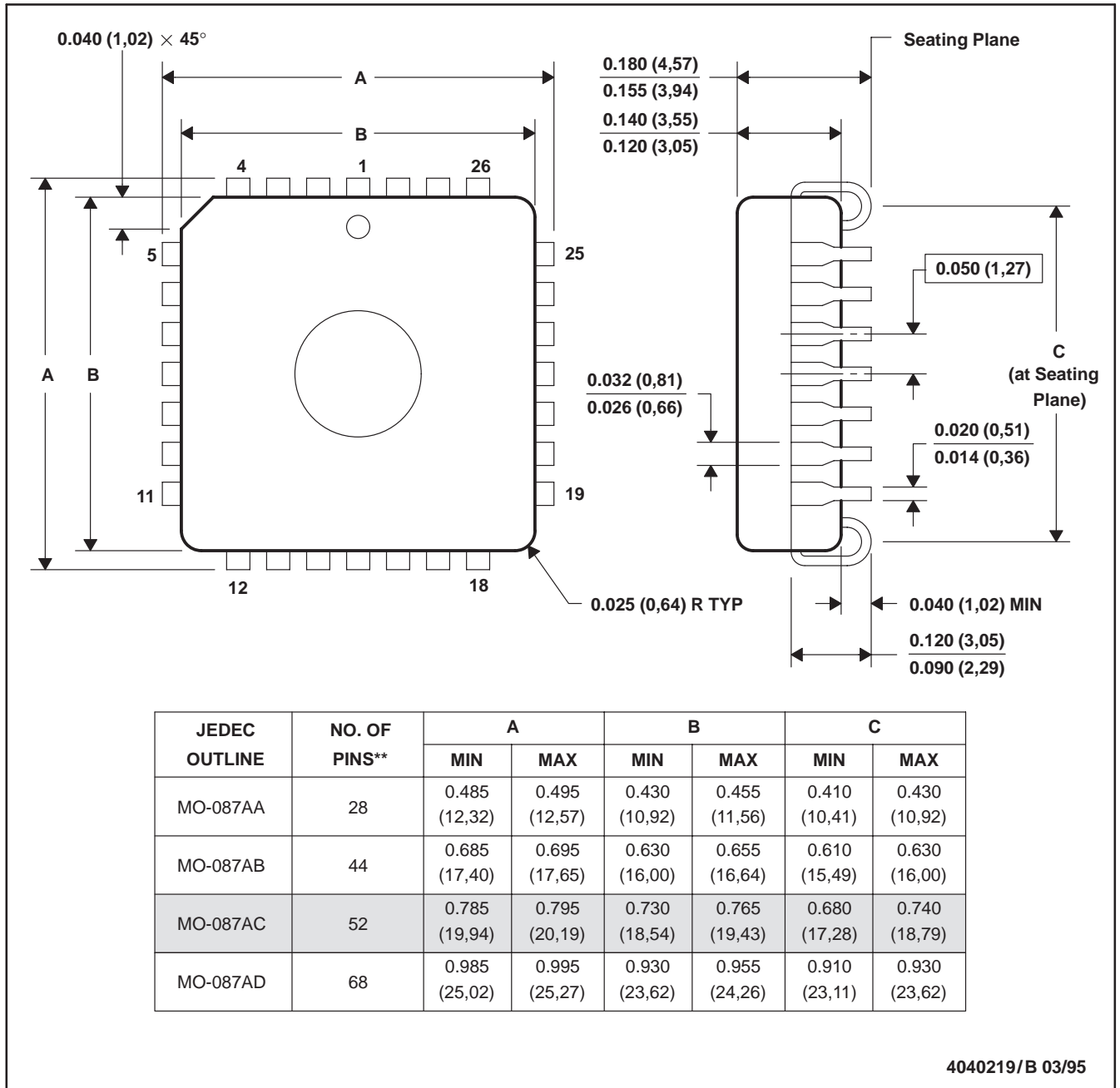

- NOTES: A. All linear dimensions are in inches (millimeters).
 B. This drawing is subject to change without notice.
 C. This package can be hermetically sealed with a ceramic lid using glass frit.

MECHANICAL DATA

JD 28- and 40-pin ceramic dual-in-line package (CDIP)

JD (R-CDIP-T**)

CERAMIC SIDE-BRAZE DUAL-IN-LINE PACKAGE

24 PIN SHOWN

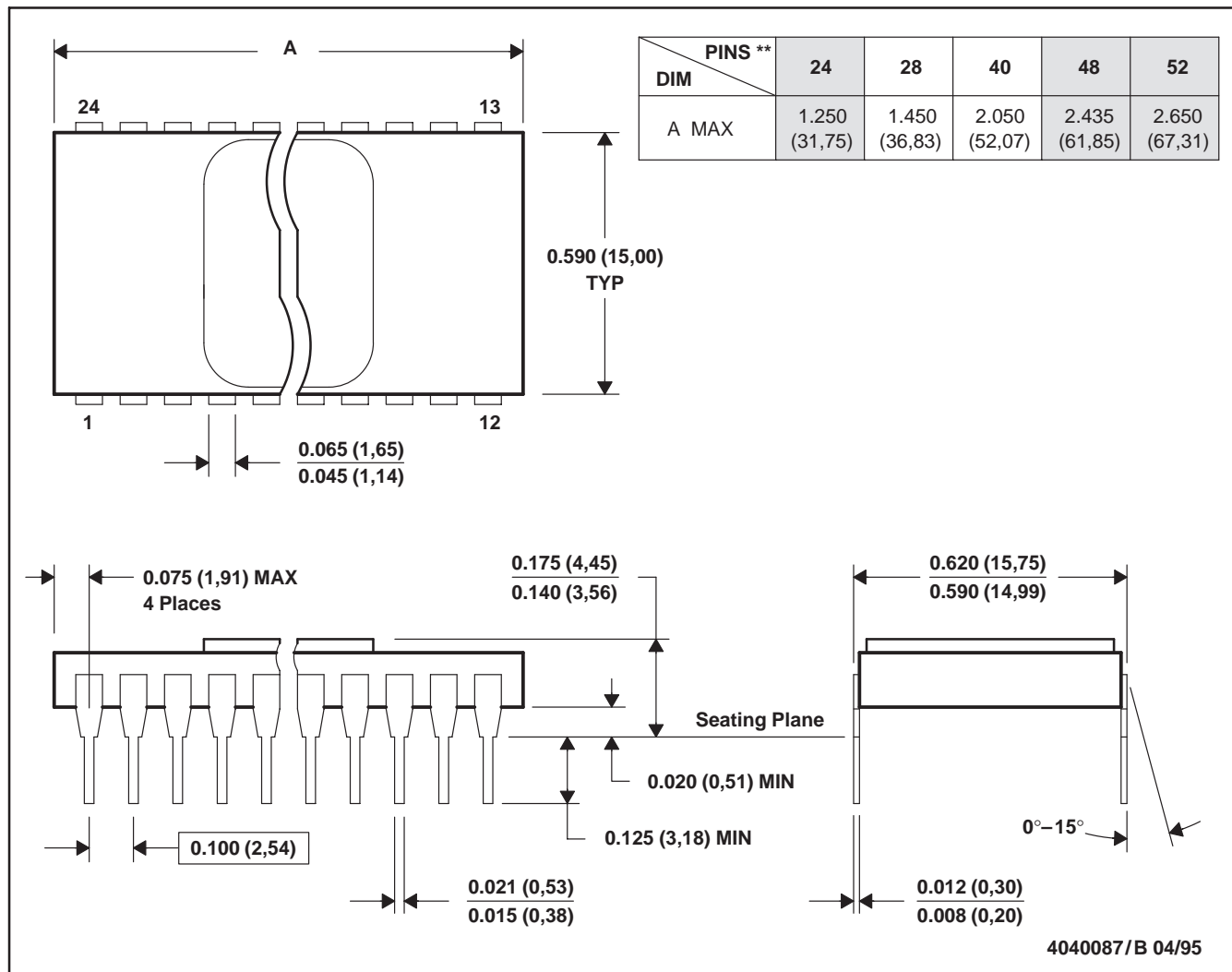

- NOTES: A. All linear dimensions are in inches (millimeters).
 B. This drawing is subject to change without notice.
 C. This package can be hermetically sealed with a metal lid.
 D. The terminals are gold plated.

MECHANICAL DATA

N 28- and 40-pin plastic dual-in-line package (PDIP) N (R-PDIP-T**)

PLASTIC DUAL-IN-LINE PACKAGE

24 PIN SHOWN

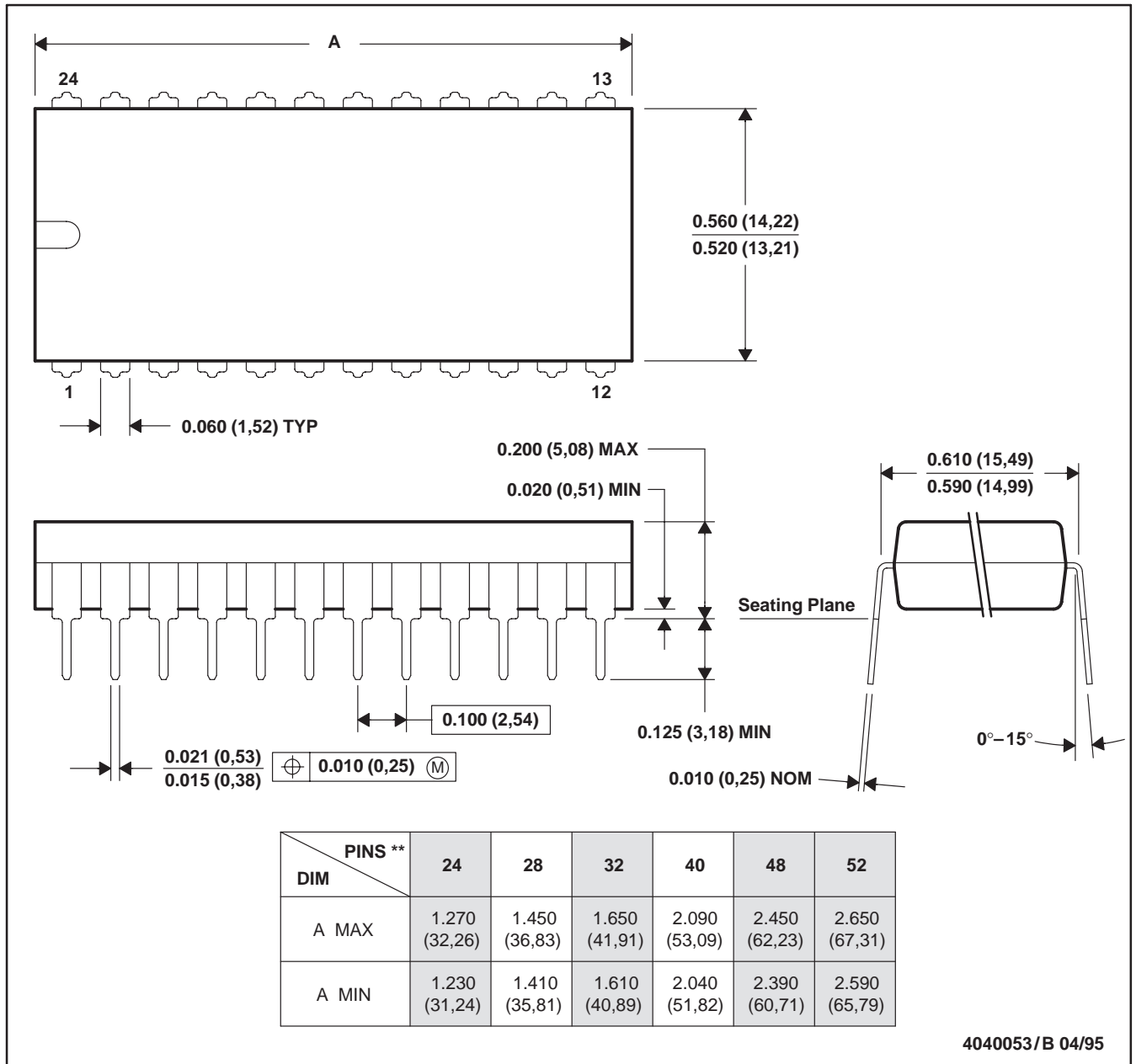

- NOTES: A. All linear dimensions are in inches (millimeters).
 B. This drawing is subject to change without notice.
 C. Falls within JEDEC MS-011
 D. Falls within JEDEC MS-015 (32 pin only)

MECHANICAL DATA

JC 40-pin ceramic shrink dual-in-line package (CSDIP)

JC (R-CDIP-T40)

CERAMIC SIDE-BRAZE DUAL-IN-LINE PACKAGE

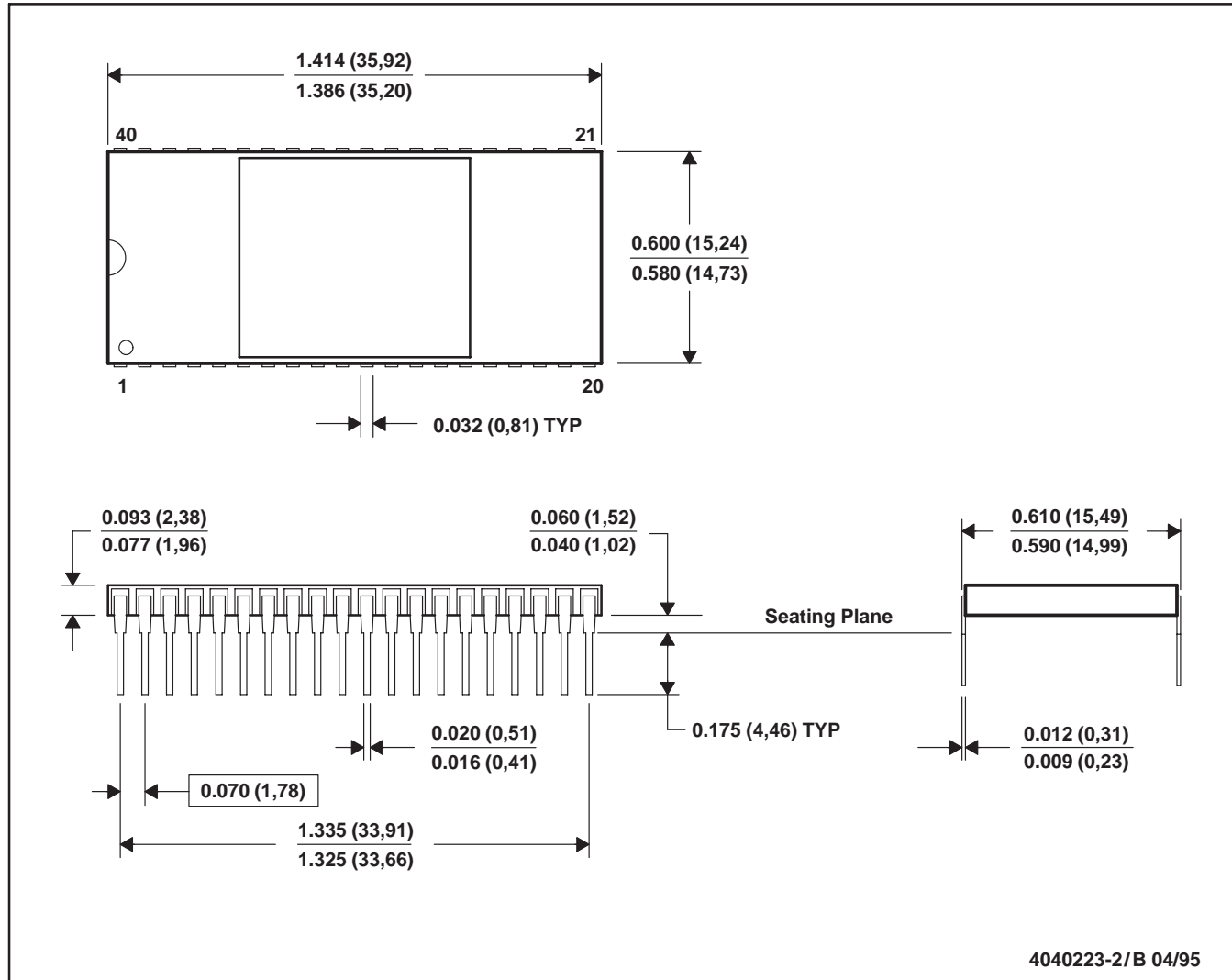

- NOTES:
- A. All linear dimensions are in inches (millimeters).
 - B. This drawing is subject to change without notice.
 - C. This package can be hermetically sealed with a metal lid.
 - D. The terminals are gold plated.

MECHANICAL DATA

NJ 40-pin plastic shrink dual-in-line package (PSDIP)

NJ (R-PDIP-T**)

PLASTIC SHRINK DUAL-IN-LINE PACKAGE

40 PIN SHOWN

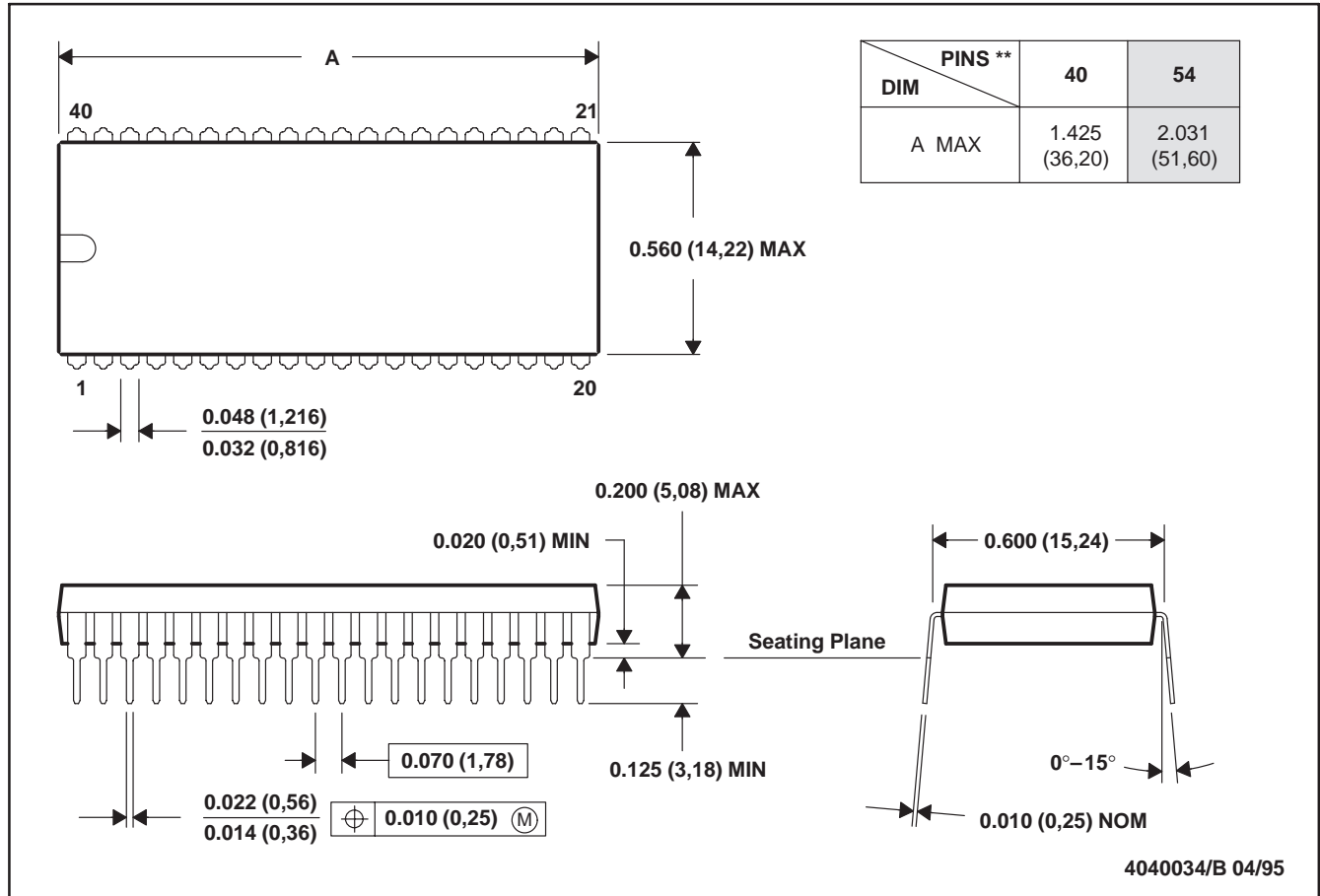

- NOTES: A. All linear dimensions are in inches (millimeters).
B. This drawing is subject to change without notice.

MECHANICAL DATA

JN 64-pin ceramic shrink dual-in-line package (CSDIP)
 JN (R-CDIP-T64)

CERAMIC DUAL-IN-LINE PACKAGE

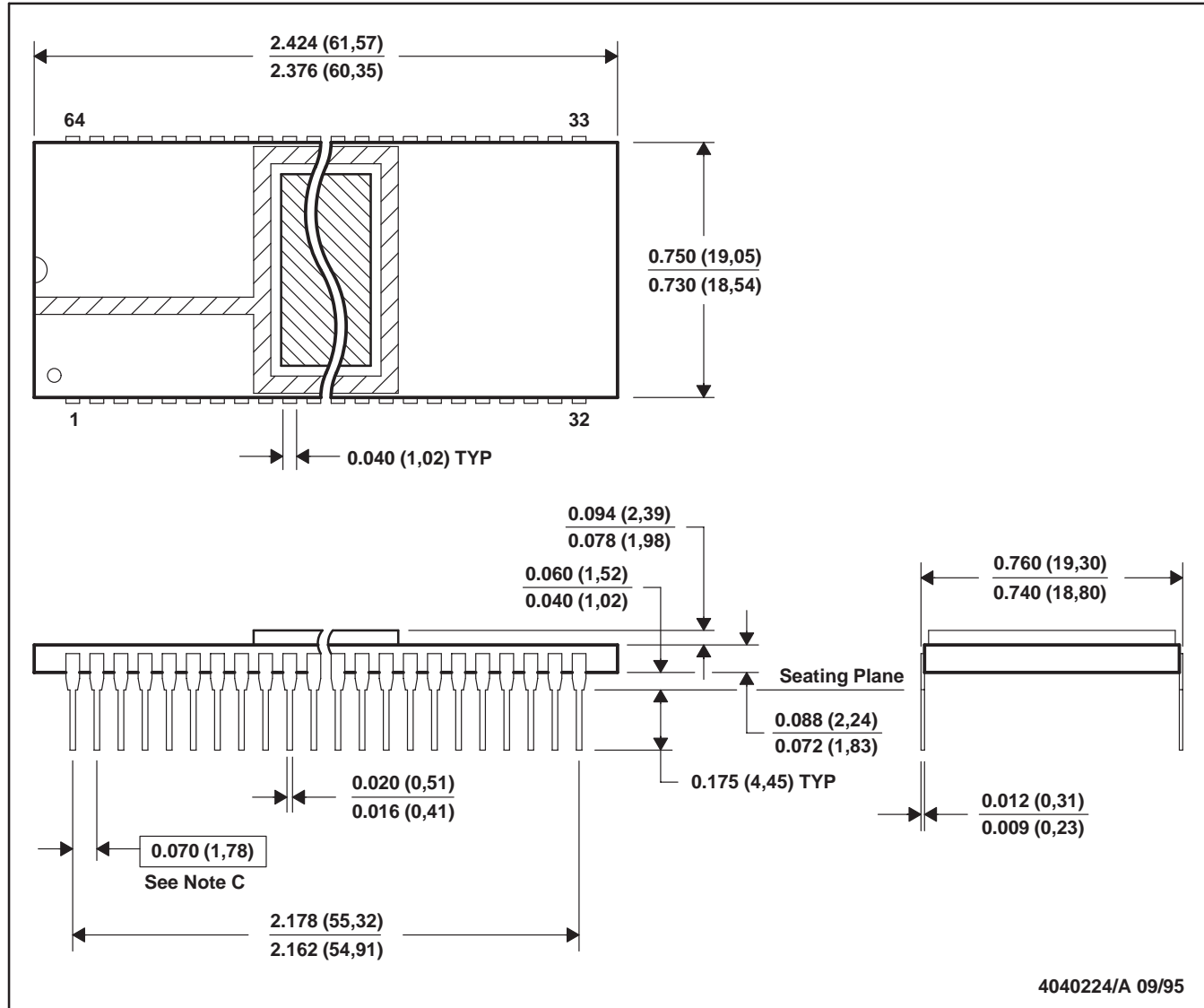

- NOTES: A. All linear dimensions are in inches (millimeters).
 B. This drawing is subject to change without notice.
 C. Each pin centerline located within 0.010 (0,26) of its true longitudinal position.

MECHANICAL DATA

NM 64-pin plastic shrink dual-in-line package (PSDIP) NM (R-PDIP-T64)

PLASTIC SHRINK DUAL-IN-LINE PACKAGE

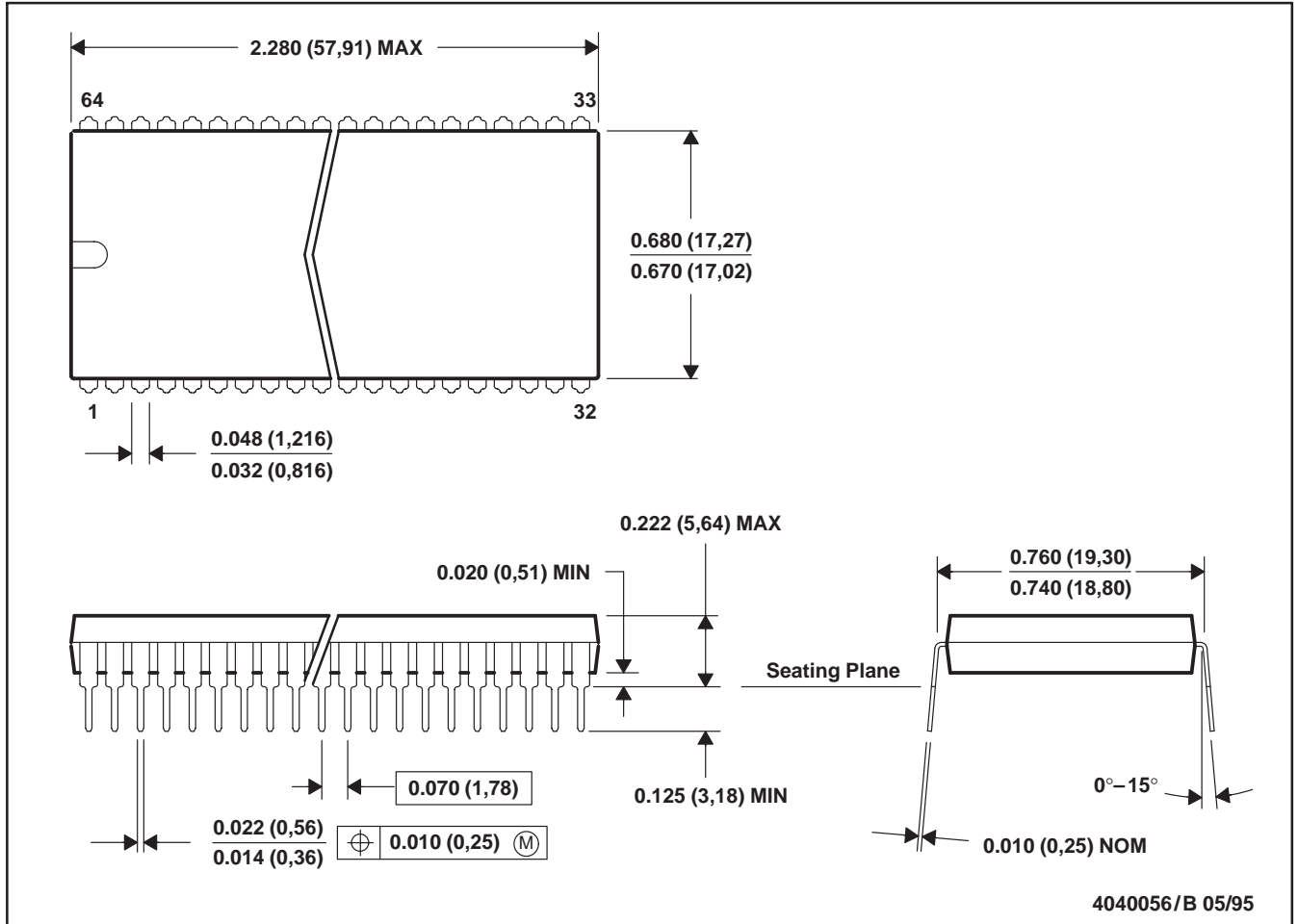

- NOTES: A. All linear dimensions are in inches (millimeters).
B. This drawing is subject to change without notice.

MECHANICAL DATA
