

# eKA8564A

## USB Audio Controller

# Product Specification

DOC. VERSION 0.1

ELAN MICROELECTRONICS CORP.

September 2006



**Trademark Acknowledgments:**

IBM is a registered trademark and PS/2 is a trademark of IBM.  
Windows is a trademark of Microsoft Corporation.

ELAN and ELAN logo  are trademarks of ELAN Microelectronics Corporation.

Copyright © 2006 by **ELAN Microelectronics Corporation**

**All Rights Reserved**

Printed in Taiwan

The contents of this specification are subject to change without further notice. ELAN Microelectronics assumes no responsibility concerning the accuracy, adequacy, or completeness of this specification. ELAN Microelectronics makes no commitment to update, or to keep current the information and material contained in this specification. Such information and material may change to conform to each confirmed order.

In no event shall ELAN Microelectronics be made responsible for any claims attributed to errors, omissions, or other inaccuracies in the information or material contained in this specification. ELAN Microelectronics shall not be liable for direct, indirect, special incidental, or consequential damages arising from the use of such information or material.

The software (if any) described in this specification is furnished under a license or nondisclosure agreement, and may be used or copied only in accordance with the terms of such agreement.

ELAN Microelectronics products are not intended for use in life support appliances, devices, or systems. Use of ELAN Microelectronics product in such applications is not supported and is prohibited.

NO PART OF THIS SPECIFICATION MAY BE REPRODUCED OR TRANSMITTED IN ANY FORM OR BY ANY MEANS WITHOUT THE EXPRESSED WRITTEN PERMISSION OF ELAN MICROELECTRONICS.



**ELAN MICROELECTRONICS CORPORATION**

**Headquarters:**

No. 12, Innovation Road 1  
Hsinchu Science Park  
Hsinchu, Taiwan 30077  
Tel: +886 3 563-9977  
Fax: +886 3 563-9966  
<http://www.emc.com.tw>

**Hong Kong:**

**Elan (HK) Microelectronics Corporation, Ltd.**  
Flat A, 19F., World Tech Centre  
95 How Ming Street, Kwun Tong  
Kowloon, HONG KONG  
Tel: +852 2723-3376  
Fax: +852 2723-7780  
[elanhk@emc.com.hk](mailto:elanhk@emc.com.hk)

**USA:**

**Elan Information Technology Group (USA)**  
1821 Saratoga Ave., Suite 250  
Saratoga, CA 95070  
USA  
Tel: +1 408 366-8225  
Fax: +1 408 366-8220

**Europe:**

**Elan Microelectronics Corp. (Europe)**

Siewerdstrasse 105  
8050 Zurich, SWITZERLAND  
Tel: +41 43 299-4060  
Fax: +41 43 299-4079  
<http://www.elan-europe.com>

**Shenzhen:**

**Elan Microelectronics Shenzhen, Ltd.**

SSMEC Bldg., 3F, Gaoxin S. Ave.  
Shenzhen Hi-Tech Industrial Park  
Shenzhen, Guangdong, CHINA  
Tel: +86 755 2601-0565  
Fax: +86 755 2601-0500

**Shanghai:**

**Elan Microelectronics Shanghai, Ltd.**

23/Bldg. #115 Lane 572, Bibo Road  
Zhangjiang Hi-Tech Park  
Shanghai, CHINA  
Tel: +86 21 5080-3866  
Fax: +86 21 5080-4600



# Contents

<b>1</b>	<b>General Description</b> .....	<b>1</b>
<b>2</b>	<b>Features</b> .....	<b>1</b>
<b>3</b>	<b>Applications</b> .....	<b>2</b>
<b>4</b>	<b>Block Diagram</b> .....	<b>2</b>
<b>5</b>	<b>Pin Configuration</b> .....	<b>3</b>
<b>6</b>	<b>Pin Assignment</b> .....	<b>4</b>
<b>7</b>	<b>Function Description</b> .....	<b>6</b>
<b>8</b>	<b>Absolute Maximum Rating</b> .....	<b>6</b>
<b>9</b>	<b>Electrical Characteristic</b> .....	<b>7</b>
	9.1 DC Electrical Characteristic.....	7
	9.2 Analog Electrical Characteristic.....	8
<b>10</b>	<b>Application Circuit</b> .....	<b>9</b>
<b>11</b>	<b>I<sup>2</sup>S Interface Signal</b> .....	<b>10</b>
<b>12</b>	<b>Package</b> .....	<b>11</b>

PRELIMINARY



### Specification Revision History

Doc. Version	Revision Description	Date
0.1	Initial Preliminary Version	2006/09/08

PRELIMINARY



## 1 General Description

The eKA8564A is a USB digital audio controller with audio data processing that supports 16-bit 2-channel format at 48kHz, 44.1kHz, 32kHz or 8kHz sampling rate. The device has an integrated USB transceiver, USB core, MCU, DAC, ADC, and I<sup>2</sup>S Input/Output. It can handle a high-level USB protocol, and manages user interface via HID I/O pins.

## 2 Features

- USB Specification v1.1 Compliant
- USB Audio and Human Interface Device (HID) Class v1.1 Compliant
- Supports 12 Mb/s Full Speed Serial Data Transmission
- Supports 48kHz, 44.1kHz, 32kHz, 8kHz sampling rate
- Single oscillator: 6MHz
- Audio buffer size: 192×16 bits × 2
- Total of four Endpoints: Endpoint 0 for control transfer, Endpoint 1 for audio streaming out, Endpoint 2 for streaming in, Endpoint 3 for HID
- Supports stereo/mono playback
- Built-in 2-channel D/A Converter with 10-bit resolution
- Built-in 1-channel A/D converter with 10-bit resolution
- Alternative settings supported by the audio streaming-out interface:
  - ALT-0: (default setting) zero isochronous bandwidth
  - ALT-1: 16-bit PCM 2 channel
- Alternative settings supported by the audio streaming-in interface:
  - ALT-0: (default setting) zero isochronous bandwidth
  - ALT-1: 16-bit PCM stereo
- 2K×13 on-chip program ROM
- 32 bytes of general purpose RAM (R20~R3F)
- RC Oscillator with internal RC
- 5 level stack for subroutine nesting
- Total of 8 HID control pins (Mute Speaker, Volume Down, Volume Up, Mute REC, Play/Pause, Stop, Scan next track, Scan previous track)
- Total of 4 LED output pins (REC Mute LED, Power LED, Play LED, SPK Mute LED)
- MCU run at 6 MHz frequency
- Package: 48-pin LQFP

### 3 Applications

- USB Speaker
- USB Microphone
- USB Telephone

### 4 Block Diagram

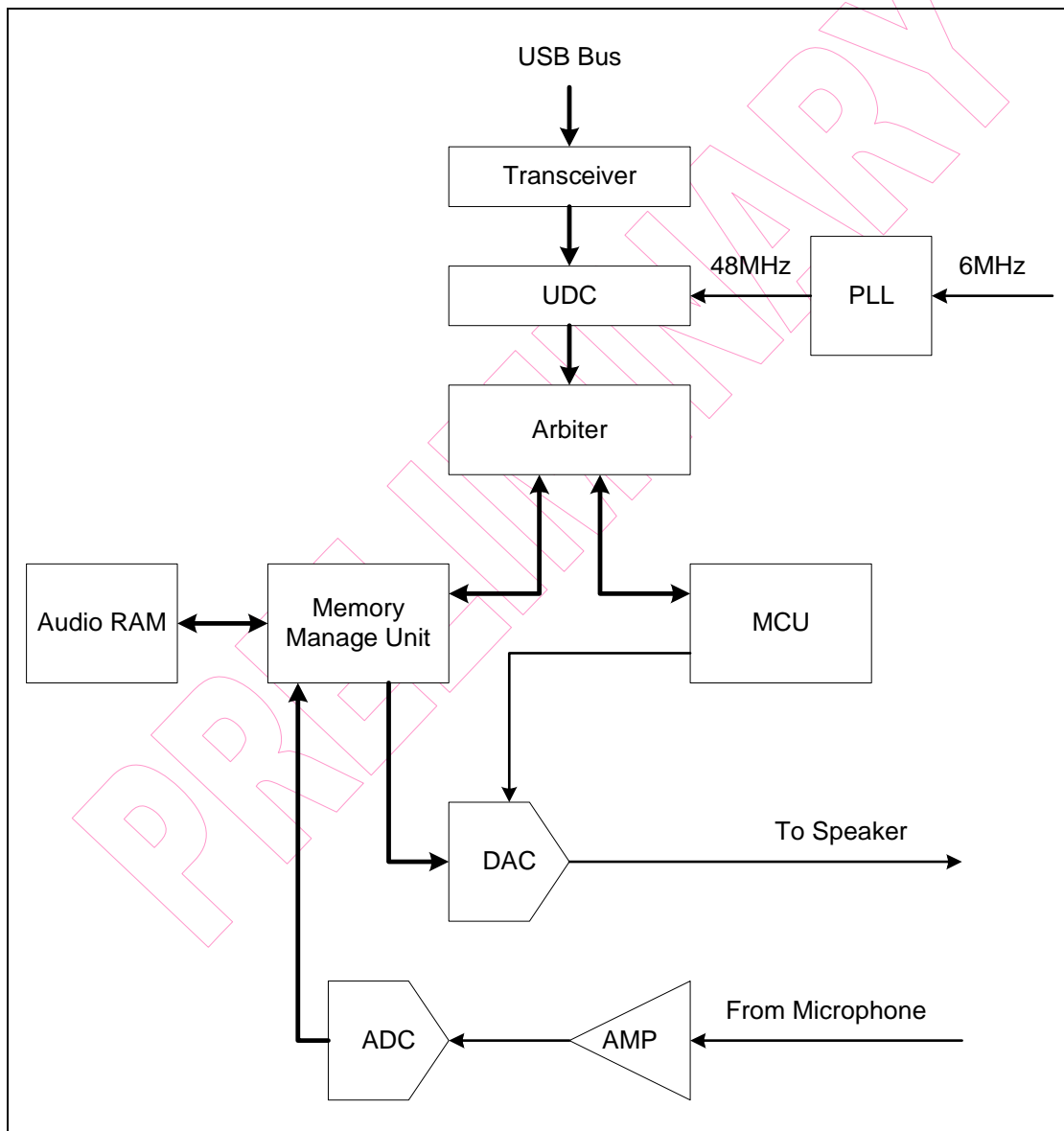

## 5 Pin Configuration

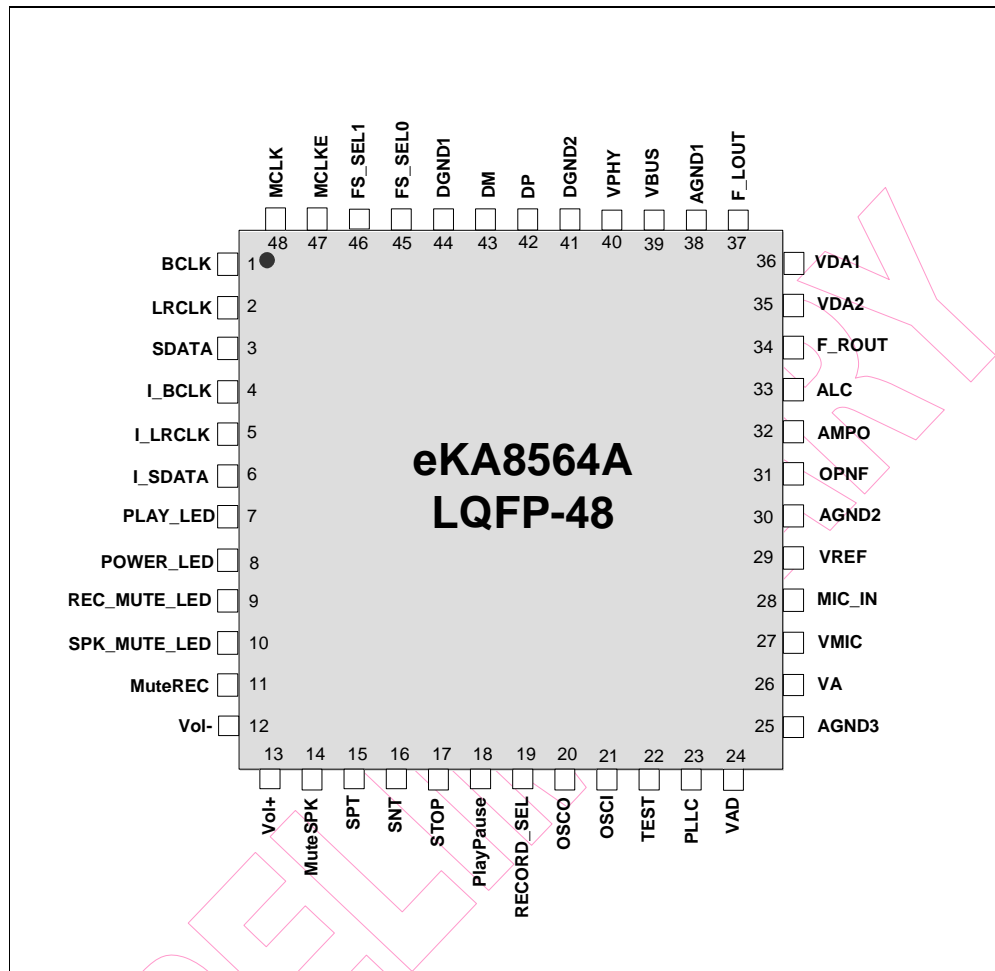

Fig 5-1 48-Pin Configuration of EKA8564A LQFP Type

## 6 Pin Assignment

Symbol	Pin No.	I/O	Function
BCLK	1	O	BCLK for I <sup>2</sup> S interface
LRCLK	2	O	LRCLK for I <sup>2</sup> S interface
SDATA	3	O	I <sup>2</sup> S interface for FL, FR output
I_BCLK	4	I	BCLK for I <sup>2</sup> S interface
I_LRCLK	5	I	LRCLK for I <sup>2</sup> S interface
I_SDATA	6	I	I <sup>2</sup> S interface for FL, FR input
Play_LED	7	O	Play LED
Power_LED	8	O	Power LED
REC_Mute_LED	9	O	Record Mute LED
SPK_Mute_LED	10	O	Speaker Mute LED
MuteREC	11	I	Mute record button
Vol-	12	I	Volume down button
Vol+	13	I	Volume up button
MuteSPK	14	I	Mute Speaker button
SPT	15	I	Media Key: Scan previous track button
SNT	16	I	Media Key: Scan next track button
Stop	17	I	Media Key: Stop button
PlayPause	18	I	Media Key: Play/Pause button
RECORD_SEL	19	I	Record select pin. 1 : I <sup>2</sup> S record 0 : ADC record An internal pull-low resistor is connected to DGND.
OSCO	20	O	Crystal output
OSCI	21	I	Crystal input
Test	22	I	Test mode select pin Test = 0, enter normal mode Test = 1, enter test mode An internal pull-low resistor is connected to DGND.
PLLC	23	I	External capacitor for PLL
VAD	24	PWR	ADC analog power supply pin
AGND3	25	-	A/D and PLL ground pin
VA	26	PWR	Analog power supply pin
VMIC	27	O	Power supply for external MIC
MIC_IN	28	I	Microphone analog input pin
Vref	29	O	Bandgap reference output
AGND2	30	-	MIC ground pin



Symbol	Pin No.	I/O	Function															
OPNF	31	I	Non-inverting type amplifier. Normally, a feedback resistor connects from AMPO to OPNF and a gain resistor connects to MIC.															
AMPO	32	O	Gain amplifier output and negative feedback terminal for MIC															
ALC	33	I	Automatic Level Control adjustment pin for MIC															
F_ROUT	34	O	Front right channel analog audio output pin															
VDA2	35	PWR	DAC analog power supply Pin 2															
VDA1	36	PWR	DAC analog power supply Pin 1															
F_LOUT	37	O	Front left channel analog audio output pin															
AGND1	38	PWR	2-channel D/A ground pin															
VBUS	39	PWR	USB bus power supply pin															
VPHY	40	PWR	PHY and PLL power supply pin															
DGND2	41	-	PHY ground pin															
DP	42	I/O	USB plus data line interface															
DM	43	I/O	USB minus data line interface															
DGND1	44	PWR	Digital ground pin															
FS_SELO FS_SEL1	45,46	I	<p>I<sup>2</sup>S's Sample Frequency</p> <table border="1"> <thead> <tr> <th></th> <th>Sample Frequency</th> <th>MCLK</th> </tr> </thead> <tbody> <tr> <td>00</td> <td>32kHz</td> <td>8.192 MHz</td> </tr> <tr> <td>01</td> <td>8kHz</td> <td>2.048 MHz</td> </tr> <tr> <td>10</td> <td>44.1kHz</td> <td>11.2896 MHz</td> </tr> <tr> <td>11</td> <td>48kHz</td> <td>12.288 MHz</td> </tr> </tbody> </table> <p>Internal pull-high resistors are connected to VD.</p>		Sample Frequency	MCLK	00	32kHz	8.192 MHz	01	8kHz	2.048 MHz	10	44.1kHz	11.2896 MHz	11	48kHz	12.288 MHz
	Sample Frequency	MCLK																
00	32kHz	8.192 MHz																
01	8kHz	2.048 MHz																
10	44.1kHz	11.2896 MHz																
11	48kHz	12.288 MHz																
MCLKE	47	I	<p>External MCLK enable pin.</p> <p><b>0</b> : use external MCLK and MCLK pin is input pin  <b>1</b> : use internal MCLK and MCLK pin is output pin</p> <p>An internal pull-high resistor is connected to VD.</p>															
MCLK	48	I/O	Crystal oscillator I/O pin															



## 7 Function Description

The eKA8564A is a USB Audio Controller that transmits/receives audio data stream to/from the host through its Audio Streaming interface. The Audio Data Format supports 16-bit, 2-channel, and 48kHz, 44.1kHz, 32kHz, 8kHz PCM. It has three interfaces. Interface 1 supports four sampling frequencies. The sampling rate is changed by FS\_SEL0 and FS\_SEL1. For Interface 2, this device transmits data at a rate that is locked to frame timing. When user uses the recording format (ex. 8kHz) to record speech other than 48kHz stereo format, the application software will transform 48kHz data to 8kHz data. Interface 3 is HID pipe which is used to read button status.

## 8 Absolute Maximum Rating

Symbol	Min	Max	Unit
Temperature under bias	0	70	°C
Storage temperature	-65	150	°C
Input voltage	-0.5	6.0	V
Output voltage	-0.5	6.0	V



## 9 Electrical Characteristic

### 9.1 DC Electrical Characteristic

Ta=0°C~70°C, VBus=5V, DGND=0V

Symbol	Parameter	Condition	Min	Typ	Max	Unit
IIL	Input Leakage Current	VIN = VBus, DGND	-	-	±1	μA
VIH	Input High Voltage	-	2.0	-	-	V
VIL	Input Low Voltage	-	-	-	2.0	V
VIHX	Clock Input High Voltage	OSCI	2.5	-	-	V
VILX	Clock Input Low Voltage	OSCI	-	-	1.0	V
VOH1	Output High Voltage (Port 5, Port 6)	IOH = -10.0mA	2.4	-	-	V
VOH2	Output High Voltage (I <sup>2</sup> S Interface Pin)	IOH = -6.67mA	2.4	-	-	V
VOL1	Output Low Voltage (Port 5, Port 6) (P5 : Normal Mode)	IOL = 10.0mA	-	-	0.4	V
VOL2	Output Low Voltage (P5 : LED driver Mode)	IOL = 10.0mA VBus = 5 V	-10%	1.3	+10%	V
VOL3	Output Low Voltage (I <sup>2</sup> S Interface Pin)	IOL = 6.67mA	-	-	0.4	V
IPH	Pull-high Current (Port 5 and Sel_Vref pin)	Pull-high active, input pin at DGND (PH resistor = 25 KΩ)	-20%	-125	+20%	μA
IPL	Pull-low Current (Test pin)	Test pin at VBus (PL resistor = 25 KΩ)	-20%	125	+20%	μA
ISB1	Power Down Current	All input and I/O pin at VBus, output pin floating, WDT disabled	-	-	50	μA
ISB2	Power Down Current	All input and I/O pin at VBus, output pin floating, WDT enabled	-	-	100	μA
ICC	Operating Supply Current	Fosc= 6.0 MHz , output pin floating	-	-	10	mA



## 9.2 Analog Electrical Characteristic

Parameter	Condition	Min	Typ	Max	Unit
<b>ADC</b>					
ADC Resolution	-	-	10	-	Bits
ADC Sampling Frequency	-	-	48	-	kHz
Internal High Reference Voltage for ADC	-	-	2.55	-	V
Internal Low Reference Voltage for ADC	-	-	0.75	-	V
<b>Pre-Amplifier Spec.</b>					
Pre-Amplifier Voltage Gain	-	19.5	20	20.5	dB
<b>Gain Amplifier Spec.</b>					
Voltage Amplifier Gain	-	49	50	51	dB
Output Voltage Swing	-	-	1.6	-	Vp-p
Output Voltage	-	0.85	-	2.45	V
<b>ALC Circuit Spec.</b>					
ALC Detection Level	MIC input = 7.5mV	-40	-	-	dBm
ALC Operating Range	-	36	40	44	dB
<b>LPF Spec</b>					
Pass-Band Ripple	-	-	-	0.5	dB
Pass-Band Cutoff Frequency	-	-	4	-	kHz
Stop-Band Attenuation @ 24kHz	-	70	-	-	dB
Stop-Band Attenuation @ 48kHz	-	90	-	-	dB
<b>DAC</b>					
DAC Resolution	-	-	10	-	Bits
DAC Sampling Frequency	-	-	48	-	kHz
Reference Voltage (Vref)	-	1.45	1.65	1.85	V
Minimum Analog Output Voltage	-	0.45	0.65	0.85	V
Maximum Analog Output Voltage	-	2.45	2.65	2.85	V
Full Scale Voltage Range	VDA=3.3V	-5%	2.0	+5%	V
Analog Output Impedance at Each Output Pin	-	-	-	200	$\Omega$
Analog Output Capacitance at Each Output Pin	-	-	-	20	pF
External Load Impedance	-	-	32	-	$\Omega$
Volume Control Step	-	-	16	-	Step



## 11 I<sup>2</sup>S Interface Signal

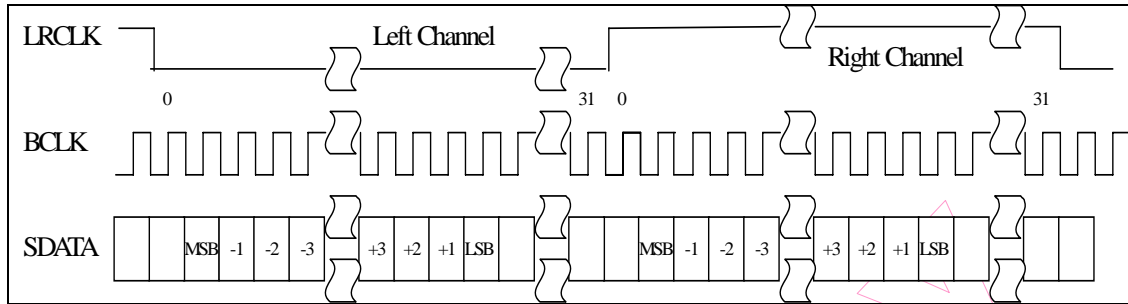

Fig 11-1 I<sup>2</sup>S Justified Audio Stream Format

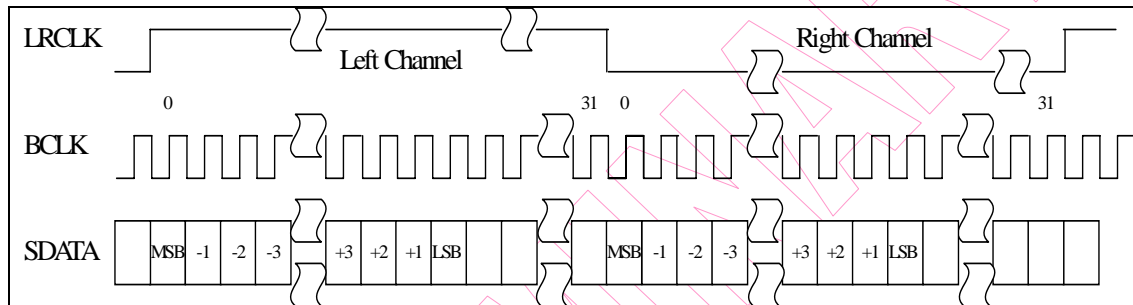

Fig 11-2 Left Justified Audio Stream Format

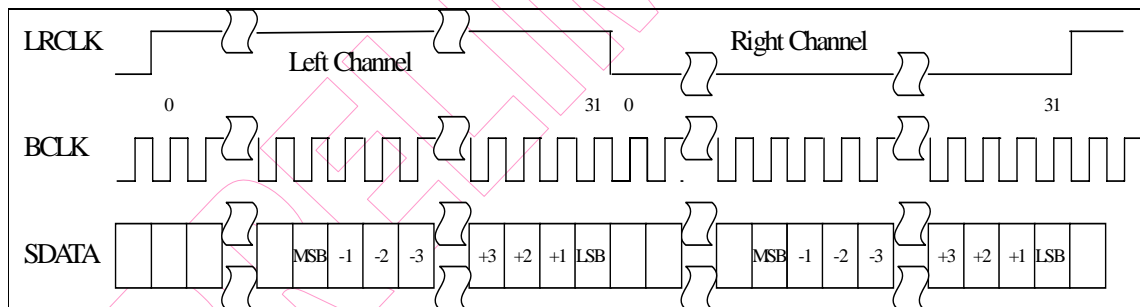

Fig 11-3 Right Justified Audio Stream Format

The LRCLK and BCLK are derived from MCLK. The frequency ratio

$$MCLK : LRCLK : BCLK = 256 : 1 : 64.$$

The frequency of LRCLK equals the sampling rate 48kHz, 44.1kHz, 32kHz or 8kHz based on FS\_SEL0 and FS\_SEL1 pins status.

## 12 Package

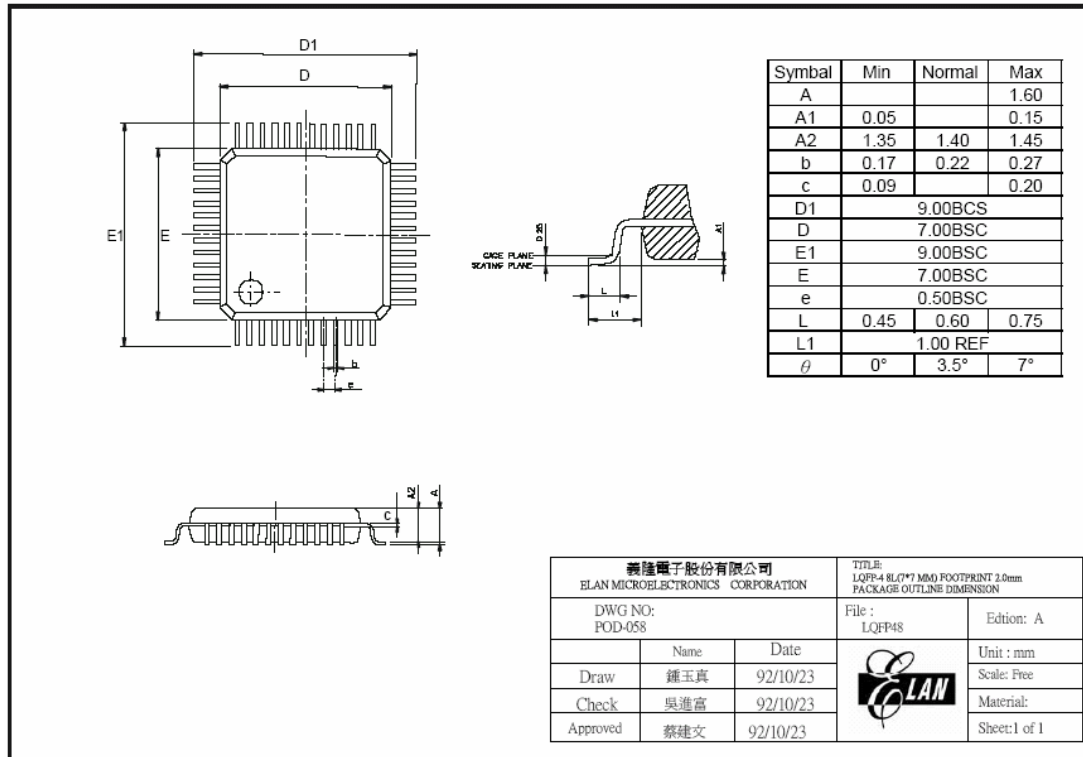

PRELIMINARY



PRELIMINARY