

eKA8566A

USB Audio Controller

Product Specification

DOC. VERSION 0.1

ELAN MICROELECTRONICS CORP.

October 2006

**Trademark Acknowledgments:**

IBM is a registered trademark and PS/2 is a trademark of IBM.

Windows is a trademark of Microsoft Corporation.

ELAN and ELAN logo  are trademarks of ELAN Microelectronics Corporation.

Copyright © 2006 by ELAN Microelectronics Corporation

All Rights Reserved

Printed in Taiwan

The contents of this specification are subject to change without further notice. ELAN Microelectronics assumes no responsibility concerning the accuracy, adequacy, or completeness of this specification. ELAN Microelectronics makes no commitment to update, or to keep current the information and material contained in this specification. Such information and material may change to conform to each confirmed order.

In no event shall ELAN Microelectronics be made responsible for any claims attributed to errors, omissions, or other inaccuracies in the information or material contained in this specification. ELAN Microelectronics shall not be liable for direct, indirect, special incidental, or consequential damages arising from the use of such information or material.

The software (if any) described in this specification is furnished under a license or nondisclosure agreement, and may be used or copied only in accordance with the terms of such agreement.

ELAN Microelectronics products are not intended for use in life support appliances, devices, or systems. Use of ELAN Microelectronics product in such applications is not supported and is prohibited.

NO PART OF THIS SPECIFICATION MAY BE REPRODUCED OR TRANSMITTED IN ANY FORM OR BY ANY MEANS WITHOUT THE EXPRESSED WRITTEN PERMISSION OF ELAN MICROELECTRONICS.

**ELAN MICROELECTRONICS CORPORATION****Headquarters:**

No. 12, Innovation Road I
Hsinchu Science Park
Hsinchu, Taiwan 30077
Tel: +886 3 563-9977
Fax: +886 3 563-9966
<http://www.emc.com.tw>

Hong Kong:

Elan (HK) Microelectronics Corporation, Ltd.
Flat A, 19F., World Tech Centre
95 How Ming Street, Kwun Tong
Kowloon, Hong Kong
Tel: +852 2723-3376
Fax: +852 2723-7780
elanhk@emc.com.hk

USA:

Elan Information Technology Group (U.S.A.)
1821 Saratoga Ave., Suite 250
Saratoga, CA 95070
U.S.A.
Tel: +1 408 366-8225
Fax: +1 408 366-8220

Europe:

Elan Microelectronics Corp. (Europe)
Siewerdtstrasse 105
8050 Zurich, Switzerland
Tel: +41 43 299-4060
Fax: +41 43 299-4079
<http://www.elan-europe.com>

Shenzhen:

Elan Microelectronics Shenzhen, Ltd.
SSMEC Bldg., 3F, Gaoxin S. Ave.
Shenzhen Hi-Tech Industrial Park
Shenzhen, Guangdong, China
Tel: +86 755 2601-0565
Fax: +86 755 2601-0500

Shanghai:

Elan Microelectronics Shanghai, Ltd.
23/Bldg. #115 Lane 572, Bibo Road
Zhangjiang Hi-Tech Park
Shanghai, China
Tel: +86 21 5080-3866
Fax: +86 21 5080-4600



Contents

1	General Description	1
2	Features	1
3	Applications	2
4	Block Diagram	2
5	Pin Configuration	3
6	Pin Assignment	4
7	Function Description	6
8	Absolute Maximum Rating	6
9	Electrical Characteristic	7
	9.1 DC Electrical Characteristic	7
	9.2 Analog Electrical Characteristic	8
10	Application Circuit	9
11	PSTN+Skype Protocol	10
	11.1 Pin Assignment for Handshaking between eKA8566A and CID	10
	11.2 Handshaking Flow Chart	11
	11.2.1 CID Request to Read Command/Data	11
	11.2.2 CID Request to Send Command/Data	12
	11.3 Command Protocol	13
	11.3.1 Reset CID	13
	11.3.2 Reset EKA8566A.....	13
	11.3.3 Key Scan	14
	11.3.4 Skype Phone On.....	16
	11.3.5 Skype Phone Off.....	17
	11.3.6 PSTN Voice Recording On	17
	11.3.7 PSTN Voice Recording Off	18
	11.3.8 Skype ID	18
	11.3.9 PSTN ID.....	21
	11.3.10 Download Phone Book	23
	11.3.11 Dial Skype Phone	28
	11.3.12 Download Vendor Data from PC to CID	30
	11.3.13 Upload Vendor Data from CID to PC.....	31
12	I²S Interface Signal	32
13	Package	33



Specification Revision History

Doc. Version	Revision Description	Date
0.1	Initial Preliminary Version	2006/10/23

PRELIMINARY



1 General Description

The eKA8566A is a USB digital audio controller with audio data processing that supports 16-bit 2-channel format at 48kHz, 44.1kHz, 32kHz or 8kHz sampling rate. The device has an integrated USB transceiver, USB core, MCU, DAC, ADC, and I²S Input/Output. It can handle a high-level USB protocol, and manages user interface via general I/O pins.

2 Features

- USB Specification v1.1 Compliant
- USB Audio and Human Interface Device (HID) Class v1.1 Compliant
- Supports 12 Mb/s Full Speed Serial Data Transmission
- Supports 48kHz, 44.1kHz, 32kHz, 8kHz sampling rate
- Single oscillator: 6MHz
- Audio buffer size: 192×16 bits × 2
- Total of four Endpoints: Endpoint 0 for control transfer, Endpoint 1 for audio streaming out, Endpoint 2 for streaming in, Endpoint 3 for HID
- Supports stereo/mono playback
- Built-in 2-channel D/A Converter with 10-bit resolution
- Built-in 1-channel A/D converter with 10-bit resolution
- Alternative settings supported by the audio streaming-out interface:
 - ALT-0: (default setting) zero isochronous bandwidth
 - ALT-1: 16-bit PCM 2 channel
- Alternative settings supported by the audio streaming-in interface:
 - ALT-0: (default setting) zero isochronous bandwidth
 - ALT-1: 16-bit PCM stereo
- 2K×13 on-chip program ROM
- 32 bytes of general purpose RAM (R20~R3F)
- RC Oscillator with internal RC
- 5 level stack for subroutine nesting
- Total of 12 I/O pins (Port 50 ~ Port 57, Port 60~Port 63)
- Supports buzzer/LED output pin
- Port 5 and Port 6 with pull-up resistors
- Wake-up pin in Port 5 and Port 6
- MCU runs at 6 MHz frequency
- Package: 48-pin LQFP

3 Applications

- Skype + PSTN (Public Switched Telephone Network)

4 Block Diagram

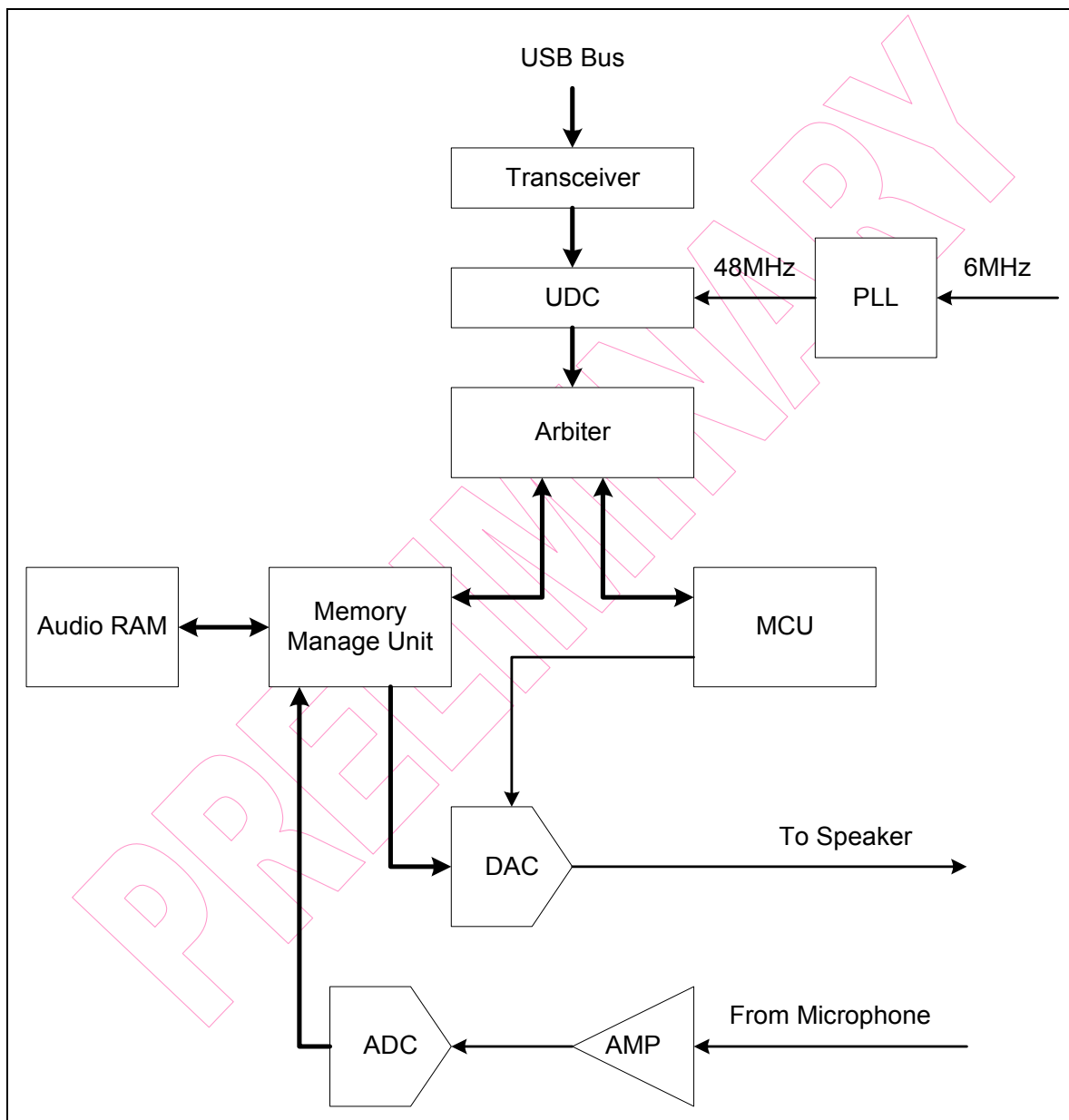

5 Pin Configuration

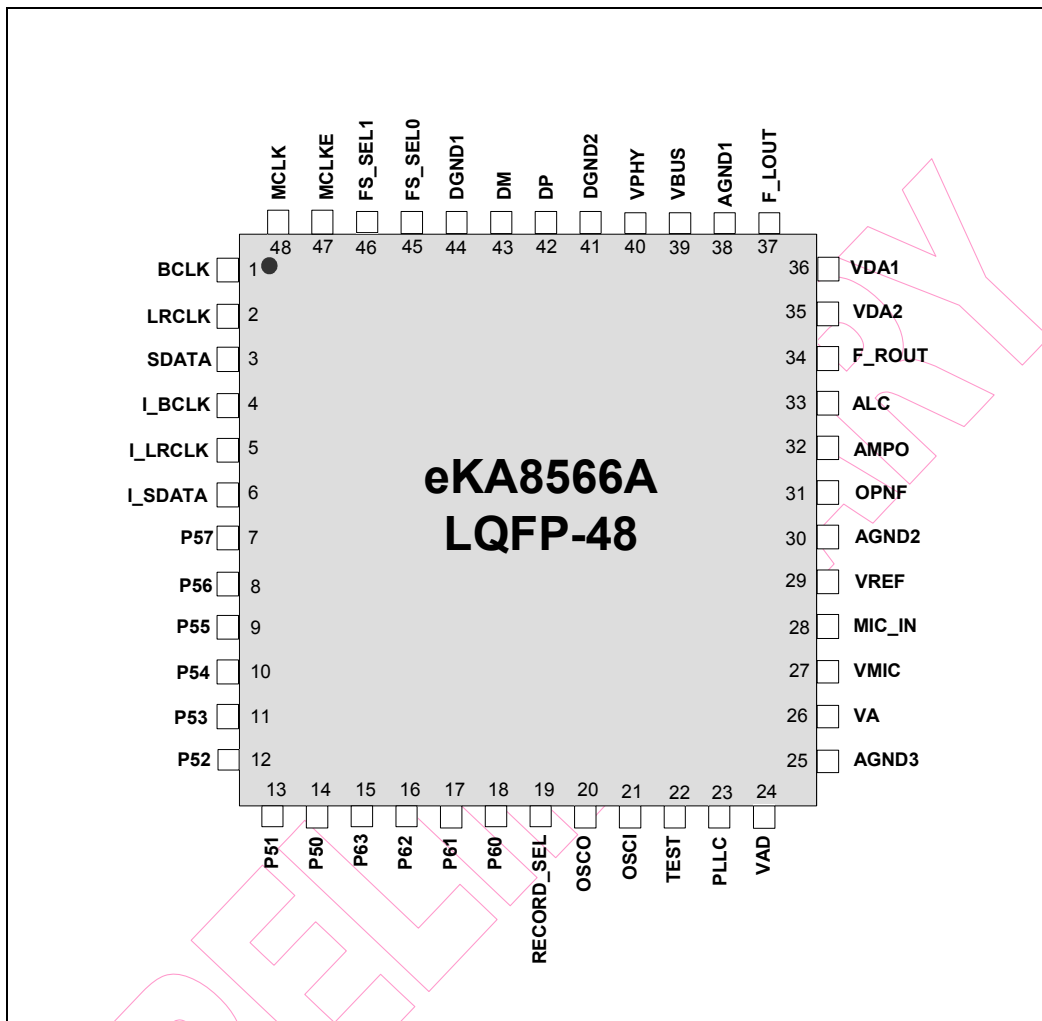

Fig. 5-1 48 Pin Configuration of EKA8566A LQFP Type

6 Pin Assignment

Symbol	Pin No.	I/O	Function
BCLK	1	O	BCLK for I ² S interface
LRCLK	2	O	LRCLK for I ² S interface
SDATA	3	O	I ² S interface for FL, FR output
I_BCLK	4	I	BCLK for I ² S interface
I_LRCLK	5	I	LRCLK for I ² S interface
I_SDATA	6	I	I ² S interface for FL, FR input
P57	7	O	AP control output pin
P56, P50	8~14	O	Reference PSTN + Skype Protocol
P63~P61	15~17	I/O	Port 6 is a 4-bit bidirectional I/O port. They can be pulled-high internally by firmware control.
P60	18	O	Reference PSTN + Skype Protocol
RECORD_SEL	19	I	Record select pin. 1 : I ² S record 0 : ADC record An internal pull-low resistor is connected to DGND.
OSCO	20	O	Crystal output
OSCI	21	I	Crystal input
Test	22	I	Test mode select pin Test = 0, enter normal mode Test = 1, enter test mode An internal pull-low resistor is connected to DGND.
PLL_C	23	I	External capacitor for PLL
VAD	24	PWR	ADC analog power supply pin
AGND3	25	-	A/D and PLL ground pin
VA	26	PWR	Analog power supply pin
VMIC	27	O	Power supply for external MIC
MIC_IN	28	I	Microphone analog input pin
Vref	29	O	Bandgap reference output
AGND2	30	-	MIC ground pin



Symbol	Pin No.	I/O	Function															
OPNF	31	I	Non-inverting type amplifier. Normally, a feedback resistor connects from AMPO to OPNF and a gain resistor connects to MIC.															
AMPO	32	O	Gain amplifier output and negative feedback terminal for MIC															
ALC	33	I	Automatic Level Control adjustment pin for MIC															
F_ROUT	34	O	Front right channel analog audio output pin															
VDA2	35	PWR	DAC analog power supply Pin 2															
VDA1	36	PWR	DAC analog power supply Pin 1															
F_LOUT	37	O	Front left channel analog audio output pin															
AGND1	38	PWR	2-channel D/A ground pin															
VBUS	39	PWR	USB bus power supply pin															
VPHY	40	PWR	PHY and PLL power supply pin															
DGND2	41	-	PHY ground pin															
DP	42	I/O	USB plus data line interface															
DM	43	I/O	USB minus data line interface															
DGND1	44	PWR	Digital ground pin															
FS_SEL0 FS_SEL1	45,46	I	<p>I²S's Sample Frequency</p> <table border="1"> <thead> <tr> <th></th> <th>Sample Frequency</th> <th>MCLK</th> </tr> </thead> <tbody> <tr> <td>00</td> <td>32kHz</td> <td>8.192 MHz</td> </tr> <tr> <td>01</td> <td>8kHz</td> <td>2.048 MHz</td> </tr> <tr> <td>10</td> <td>44.1kHz</td> <td>11.2896 MHz</td> </tr> <tr> <td>11</td> <td>48kHz</td> <td>12.288 MHz</td> </tr> </tbody> </table> <p>Internal pull-high resistors are connected to VD.</p>		Sample Frequency	MCLK	00	32kHz	8.192 MHz	01	8kHz	2.048 MHz	10	44.1kHz	11.2896 MHz	11	48kHz	12.288 MHz
	Sample Frequency	MCLK																
00	32kHz	8.192 MHz																
01	8kHz	2.048 MHz																
10	44.1kHz	11.2896 MHz																
11	48kHz	12.288 MHz																
MCLK	47	I	<p>External MCLK enable pin.</p> <p>0 : use external MCLK and MCLK pin is input pin 1 : use internal MCLK and MCLK pin is output pin</p> <p>An internal pull-high resistor is connected to VD.</p>															
MCLK	48	I/O	Crystal oscillator I/O pin															

7 Function Description

The eKA8566A is a USB Audio Controller that transmits/receives audio data stream to / from the host through its Audio Streaming interface. The Audio Data Format supports 16-bit, 2-channel, and 48kHz, 44.1kHz, 32kHz, 8kHz PCM. It has three interfaces. Interface 1 supports four sampling frequencies. The sampling rate is changed by FS_SEL0 and FS_SEL1. For Interface 2, this device transmits data at a rate that is locked to frame timing. When user uses the recording format (ex. 8kHz) to record speech other than 48kHz stereo format, the application software will transform 48kHz data to 8kHz data. Interface 3 is HID pipe which is used to read user data.

The EKA8566A defines a PSTN + Skype protocol to communicate with an external MCU. The device can use the protocol to by pass USB vendor data to external MCU or read data from external MCU to USB host.

8 Absolute Maximum Rating

Symbol	Min	Max	Unit
Temperature under bias	0	70	°C
Storage temperature	-65	150	°C
Input voltage	-0.5	6.0	V
Output voltage	-0.5	6.0	V



9 Electrical Characteristic

9.1 DC Electrical Characteristic

Ta = 0°C~70°C, VBus = 5V, DGND = 0V

Symbol	Parameter	Condition	Min	Typ	Max	Unit
IIL	Input Leakage Current	VIN = VBus, DGND	-	-	±1	μA
VIH	Input High Voltage	-	2.0	-	-	V
VIL	Input Low Voltage	-	-	-	0.8	V
VIHX	Clock Input High Voltage	OSCI	2.5	-	-	V
VILX	Clock Input Low Voltage	OSCI	-	-	1.0	V
VOH1	Output High Voltage (Port 5, Port 6)	IOH = -10.0mA	2.4	-	-	V
VOH2	Output High Voltage (I ² S Interface Pin)	IOH = -6.67mA	2.4	-	-	V
VOL1	Output Low Voltage (Port 5, Port 6) (P5 : Normal Mode)	IOL = 10.0mA	-	-	0.4	V
VOL2	Output Low Voltage (P5 : LED driver Mode)	IOL = 10.0mA VBus = 5 V	-10%	1.3	+10%	V
VOL3	Output Low Voltage (I ² S Interface Pin)	IOL = 6.67mA	-	-	0.4	V
IPH	Pull-high Current (Port 5 and Sel_Vref pin)	Pull-high active, input pin at DGND (PH resistor = 25KΩ)	-20%	-125	+20%	μA
IPL	Pull-low Current (Test pin)	Test pin at VBus (PL resistor = 25KΩ)	-20%	125	+20%	μA
ISB1	Power Down Current	All input and I/O pin at VBus, output pin floating, WDT disabled	-	-	50	μA
ISB2	Power Down Current	All input and I/O pin at VBus, output pin floating, WDT enabled	-	-	100	μA
ICC	Operating Supply Current	Fosc= 6.0 MHz , output pin floating	-	-	10	mA

9.2 Analog Electrical Characteristic

Parameter	Condition	Min	Typ	Max	Unit
ADC					
ADC Resolution	–	–	10	–	Bits
ADC Sampling Frequency	–	–	48	–	kHz
Internal High Reference Voltage for ADC	–	–	2.55	–	V
Internal Low Reference Voltage for ADC	–	–	0.75	–	V
Pre-Amplifier Spec.					
Pre-Amplifier Voltage Gain	–	19.5	20	20.5	dB
Gain Amplifier Spec.					
Voltage Amplifier Gain	–	49	50	51	dB
Output Voltage Swing	–	–	1.6	–	Vp-p
Output Voltage	–	0.85	–	2.45	V
ALC Circuit Spec.					
ALC Detection Level	MIC input = 7.5mV	-40	–	–	dBm
ALC Operating Range	–	36	40	44	dB
LPF Spec					
Pass-Band Ripple	–	–	–	0.5	dB
Pass-Band Cutoff Frequency	–	–	4	–	kHz
Stop-Band Attenuation @ 24kHz	–	70	–	–	dB
Stop-Band Attenuation @ 48kHz	–	90	–	–	dB
DAC					
DAC Resolution	–	–	10	–	Bits
DAC Sampling Frequency	–	–	48	–	kHz
Reference Voltage (Vref)	–	1.45	1.65	1.85	V
Minimum Analog Output Voltage	–	0.45	0.65	0.85	V
Maximum Analog Output Voltage	–	2.45	2.65	2.85	V
Full Scale Voltage Range	VDA=3.3V	-5%	2.0	+5%	V
Analog Output Impedance at Each Output Pin	–	–	–	200	Ω
Analog Output Capacitance at Each Output Pin	–	–	–	20	pF
External Load Impedance	–	–	32	–	Ω
Volume Control Step	–	–	16	–	Step

11 PSTN+Skype Protocol

11.1 Pin Assignment for Handshaking between eKA8566A and CID

Symbol	I/O	Function	Note
DATA3~0	I/O	Data bus	–
CLK	O	Clock pin	–
DIR	O	DIR = 0 : EKA8566A writes data to CID DIR = 1 : EKA8566A reads data from CID	CID must not drive a Data bus, when DIR is in low state.
CRS	I	a. When EKA8566A sends command/data to CID, CRS is used to indicate if CID receives the command/data. CRS is asserted after CLK is asserted, CRS is de-asserted after CLK is de-asserted. If CRS is not asserted, then indicate that CID does not receive command/data. b. When CID requests to send command/data to EKA8566A, CRS will be asserted. CLK is asserted after CRS is asserted, CLK is de-asserted after CRS is de-asserted. If CLK is not asserted, then indicate that the EKA8566A does not receive command/data.	–
CID_PWR	I	CID_PWR=0: CID is in power down CID_PWR=1: CID is in power on	–

Note: I – signal is from CID to eKA8566A.

O – signal is from eKA8566A to CID.

11.2 Handshaking Flow Chart

11.2.1 CID Request to Read Command/Data

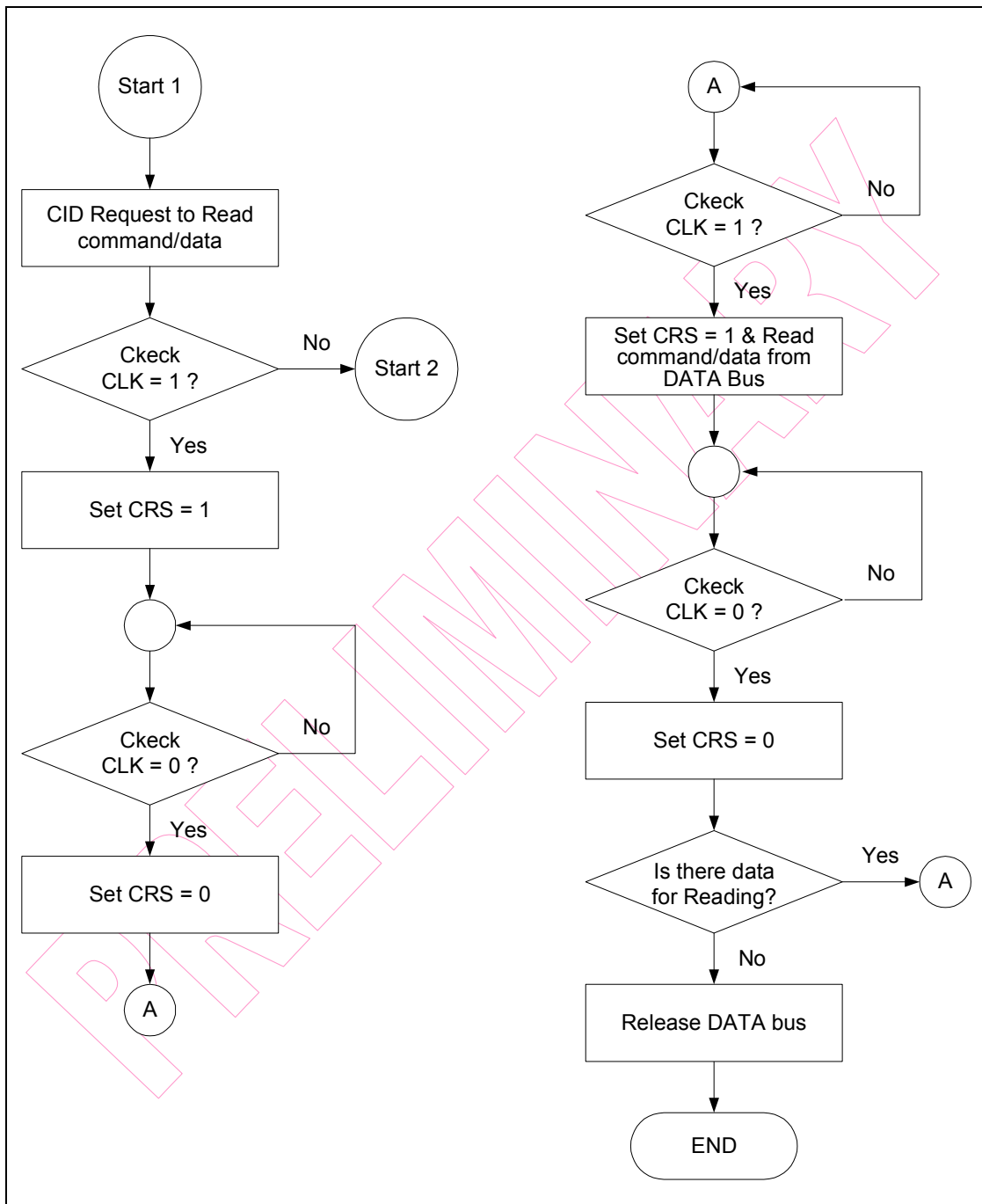



11.2.2 CID Request to Send Command/Data

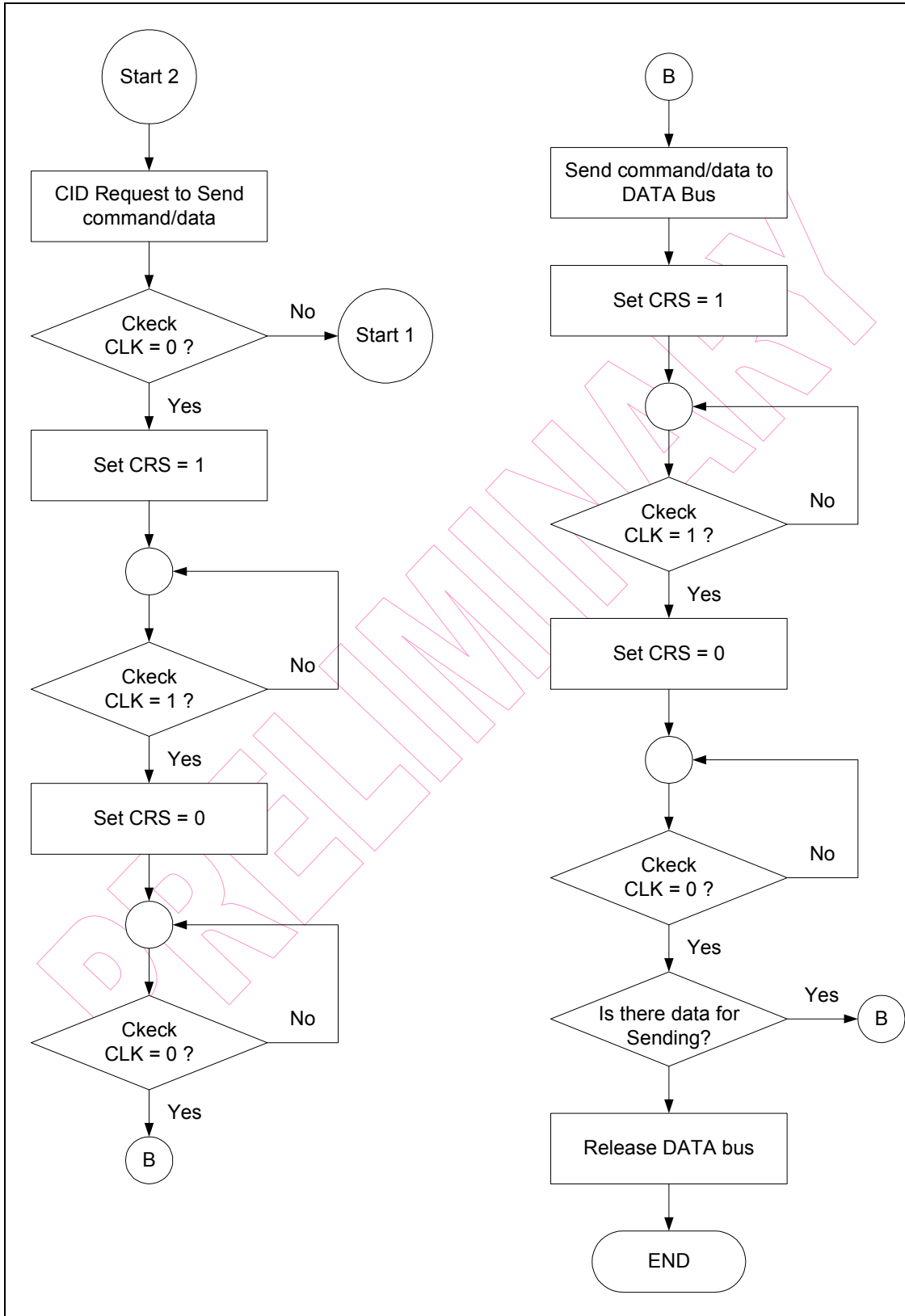

11.3 Command Protocol

Command List

Command	From EKA8566A to CID	From CID to EKA8566A
0x0	Reset CID	Reset EKA8566A
0x1	-	Key scan
0x2	Skype Phone on	-
0x3	Skype Phone off	-
0x4	-	PSTN voice recording on
0x5	-	PSTN voice recording off
0x6	Skype ID	-
0x7	-	PSTN ID
0x8	Download Phone book	-
0x9	-	Dial Skype Phone
0xA	Vendor data from EKA8566A to CID	Vendor data from CID to EKA8566A
0xB	Vendor data from EKA8566A to CID	Vendor data from CID to EKA8566A
0xC	Vendor data from EKA8566A to CID	Vendor data from CID to EKA8566A
0xD	Vendor data from EKA8566A to CID	Vendor data from CID to EKA8566A
0xE	Vendor data from EKA8566A to CID	Vendor data from CID to EKA8566A
0xF	Vendor data from EKA8566A to CID	Vendor data from CID to EKA8566A

11.3.1 Reset CID

Format: cmd (0x0)

Description: EKA8566A reset CID

Timing:

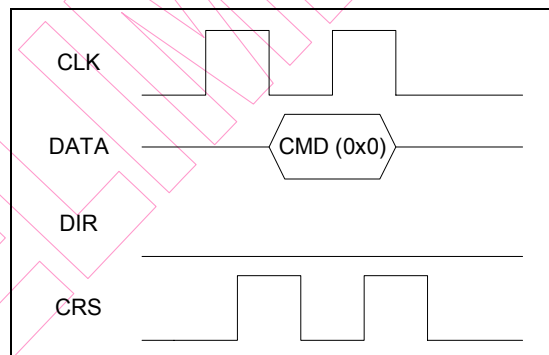

11.3.2 Reset EKA8566A

Format: cmd (0x0)

Description: CID reset EKA8566A

Timing:

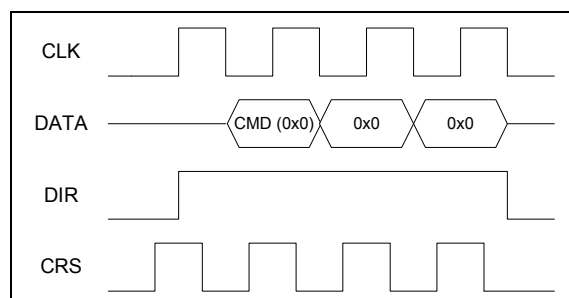

11.3.3 Key Scan

Format: cmd (0x1) + data (1 byte)

a. Button Pressed Command: cmd (0x1) + Key Code (0~254)

b. Button Released Command: cmd (0x1) + 0xF + 0xF

Description:

a. CID send the key scanned to EKA8566A

b. MSB significant nibble is sent first.

Timing:

1. Button Pressed Command (Key code=0~254)

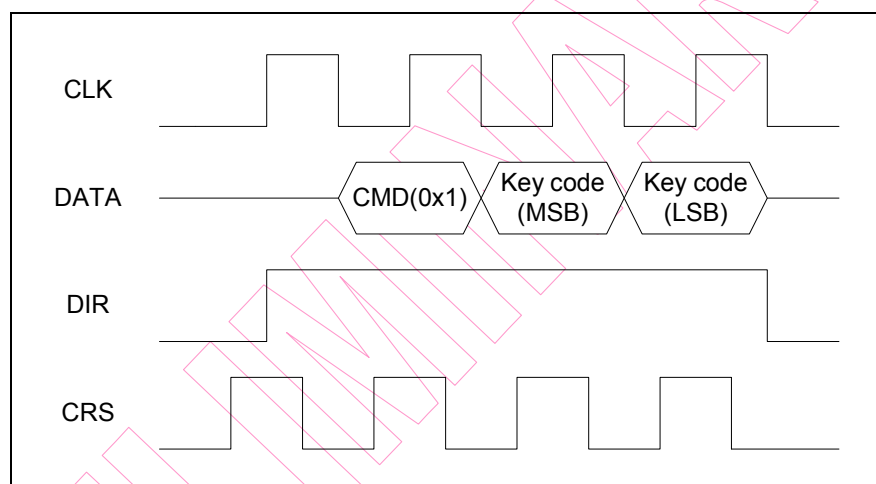

2. Button Released Command (Key code=255)

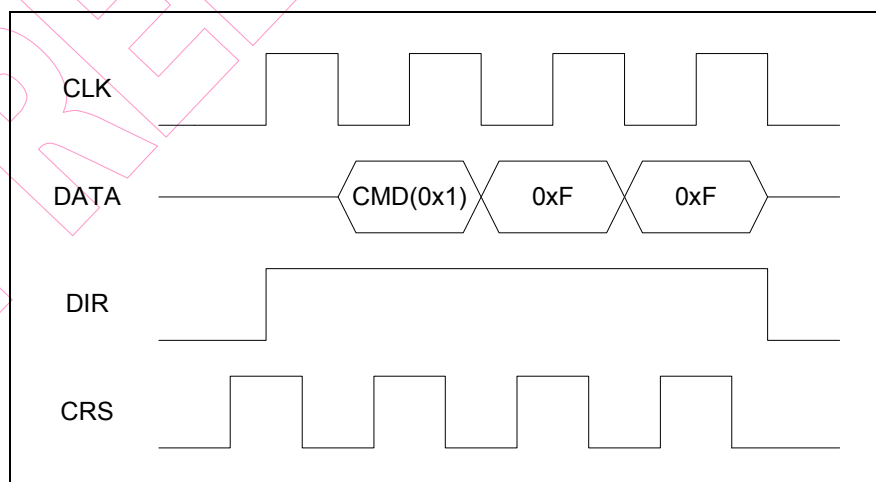



Key Description:

Function Key	Function Description
IN	Received Calls Record In idle or dialing state, press this key to search for the historical record of received calls.
OUT	Dialled Number Record In idle or dialing state, press this key to search for the historical record of dialed-out telephone numbers.
Up	Previous Page 1. During dialled-in/out history search, press this key to search record upward. 2. In other non-search states, this key functions as “Up” key of Skype’s up/down function keys.
Down	Next Page 1. During dialled-in/out history search, press this key to search record downward. 2. In other non-search states, this key functions as “Down” key of Skype’s up/down function keys
C	Clear 1. During dialled-in/out history search, press this key twice to delete the existing records. 2. During dial-out state, press this key to delete the last entered letter or character. 3. With no letter or character entered, pressing this key will switch the Skype window label.
Off-hook	Dial Out/Answer Key 1. When Skype window is hidden, press this key to display Skype window. 2. When on-line with called party, pressing this key has no effect. 3. In other states, press this key to send out Skype dialled number.
On-hook	On-hook Key 1. In Idle state, press this key to hide the Skype window. 2. In dialling state, pres this key to clear all entered numbers. 3. In other states, press this key to set Skype in on-hook position.
0-9, *, #	1. In Idle state, press these keys to enter dialing state. 2. When on-line with called party, press these keys to send DTMF signal to Skype.

Key Table:

Key Code	Key	Key Code	Key
0 (0x00)	Mute	25 (0x19)	Require Phonebook
1 (0x01)	Vol+	26 (0x1A)	Hang-On
2 (0x02)	Vol-	27 (0x1B)	Hang-Off
3 (0x03)	--	--	--
4 (0x04)	Up	--	--
5 (0x05)	--	--	--
6 (0x06)	In	--	--
7 (0x07)	Down	--	--
8 (0x08)	Out	--	--
9 (0x09)	Off Hook (Dial)	--	--
10 (0x0A)	C	--	--
11 (0x0B)	On Hook	--	--
12 (0x0C)	1	--	--
13 (0x0D)	2	--	--
14 (0x0E)	3	--	--
15 (0x0F)	4	--	--
16 (0x10)	5	--	--
17 (0x11)	6	--	--
18 (0x12)	7	--	--
19 (0x13)	8	--	--
20 (0x14)	9	--	--
21 (0x15)	*	--	--
22 (0x16)	0	--	--
23 (0x17)	#	--	--
24 (0x18)	+	255 (0xFF)	Button Release

11.3.4 Skype Phone On

Format: cmd (0x2)

Description: When turning on the Skype phone, the EKA8566A notifies the CID.

Timing:

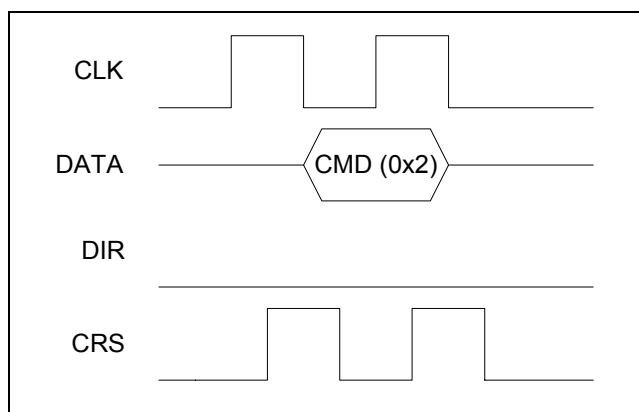

11.3.5 Skype Phone Off

Format: cmd (0x3)

Description: When turning off the Skype phone, the EKA8566A notifies the CID.

Timing:

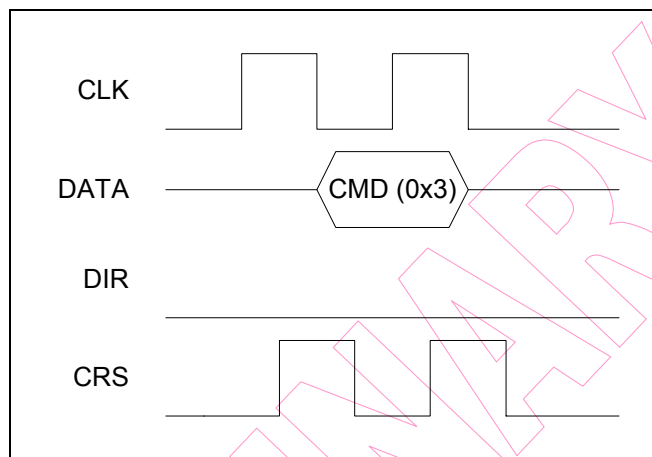

11.3.6 PSTN Voice Recording On

Format: cmd (0x4) + voice data

Description:

- The PC records the 1-byte PSTN voice data, this byte is not the last byte.
- MSB significant nibble is sent first.

Timing:

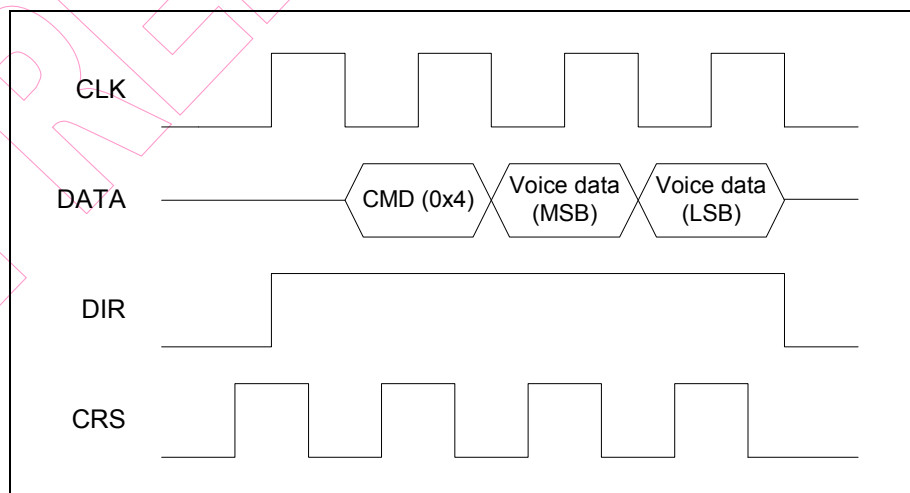

11.3.7 PSTN Voice Recording Off

Format: cmd (0x5) + voice data

Description:

- The PC records 1-byte PSTN voice data and this byte is the last byte.
- MSB significant nibble sent first.

Timing:

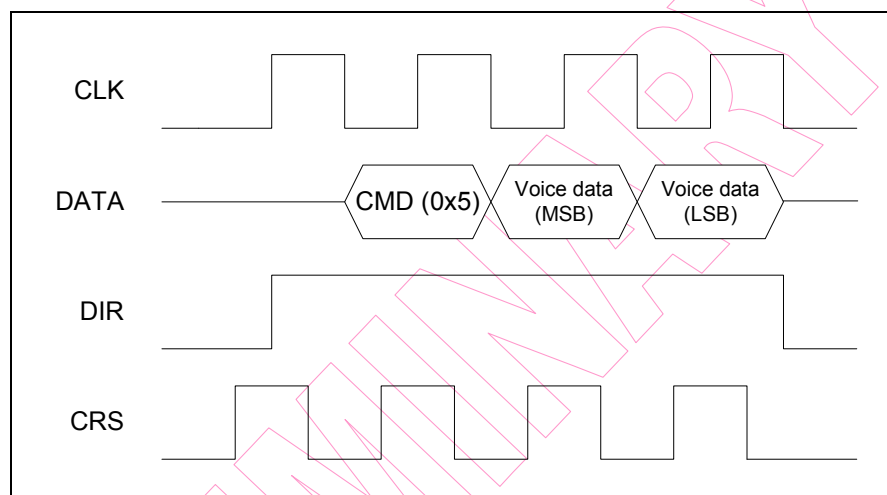

11.3.8 Skype ID

Format: cmd (0x6) + byte number of caller name + nibble number of telephone number + caller name + telephone number

Description:

- When Skype phone is ringing, the PC sends the account and telephone number to the CID for display on LCM.
- If using Unicode, then two bytes denote one character of account; if using ASCII code, then one byte denotes one character of account. This is dependent on user's choice.
- 4 bits denote a telephone number digit.
- MSB significant nibble is sent first.

Timing:

1) CMD + Data length

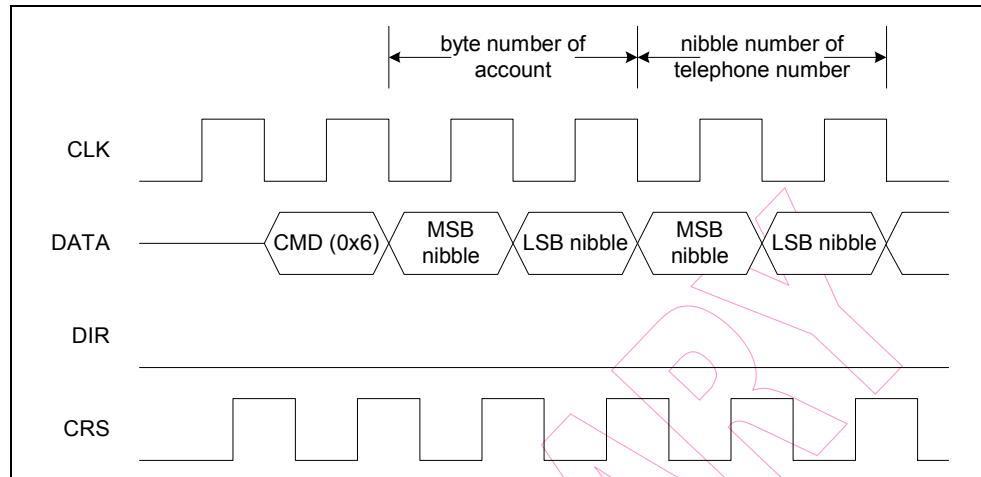

2) Caller Name

A. Skype account coded by Unicode

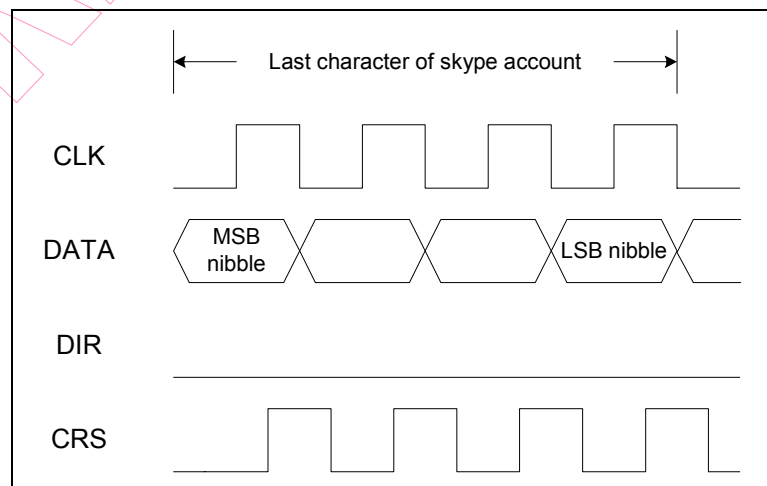
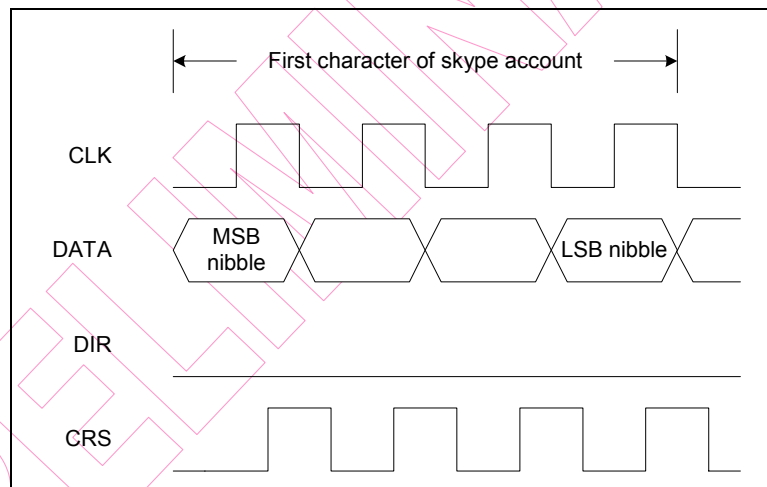

B. Skype account coded by ASCII code

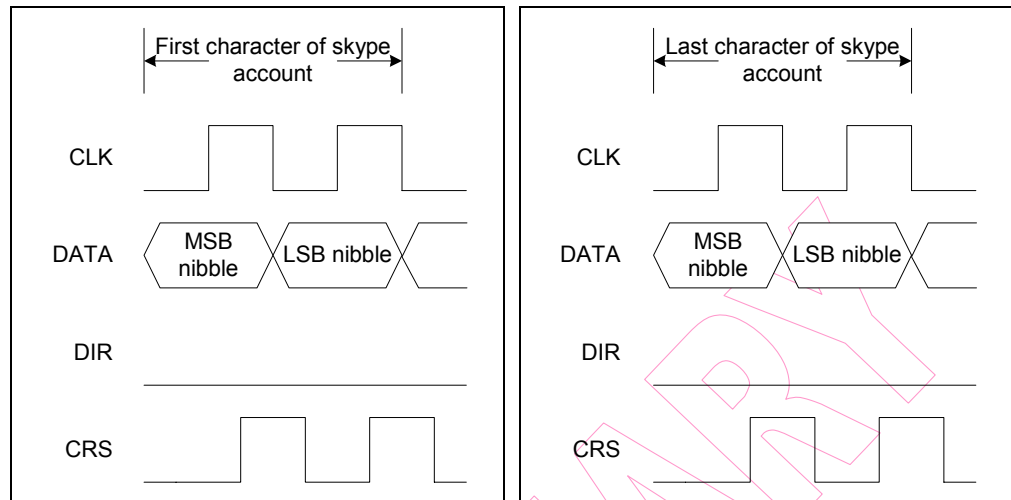

3) Phone Number

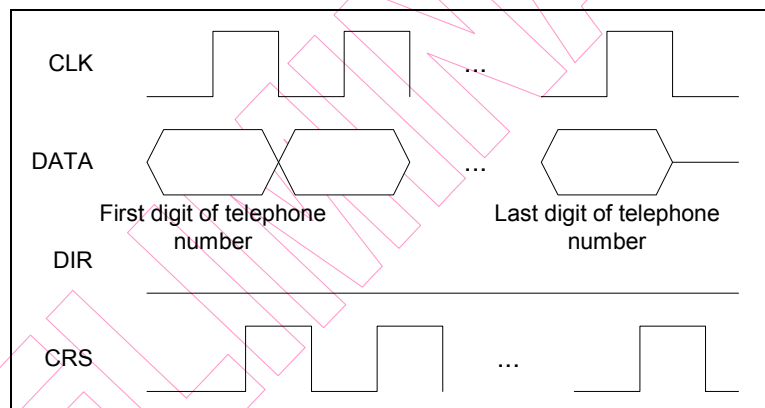

11.3.9 PSTN ID

Format: cmd (0x7) + byte number of PSTN account + byte number of telephone number + PSTN account + telephone number

Description:

- a. When PSTN phone call is ringing, the CID sends the PSTN account and telephone number to the PC for display on PC.
- b. If using Unicode, then two byte denote one character of account; if using ASCII code, then one denotes one character of account. This is dependent on the choice of user.
- c. 4 bits denote a digit of telephone number.
- d. MSB significant nibble sent first.

Timing:

1) CMD + Data length

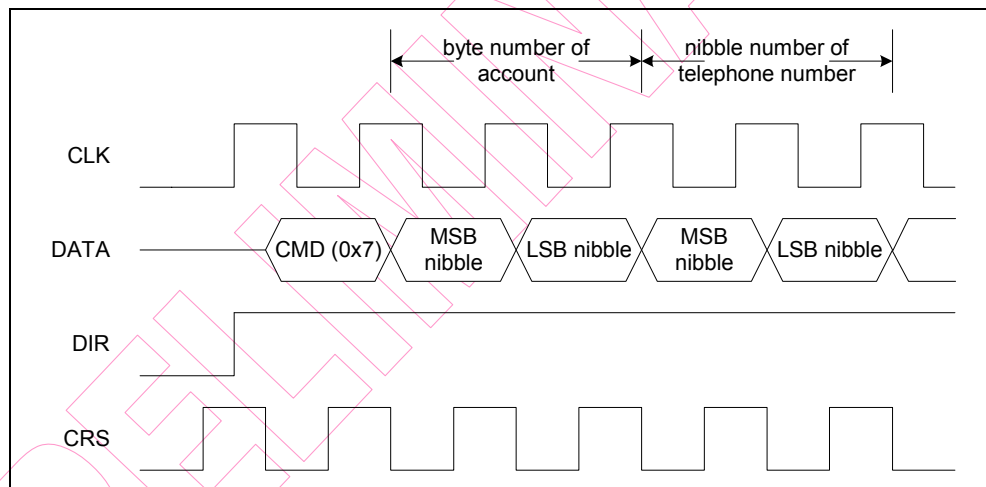

2) PSTN account

A. PSTN account coded by Unicode

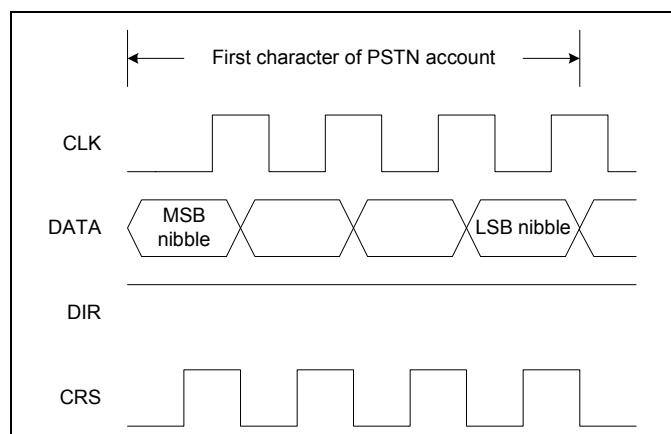

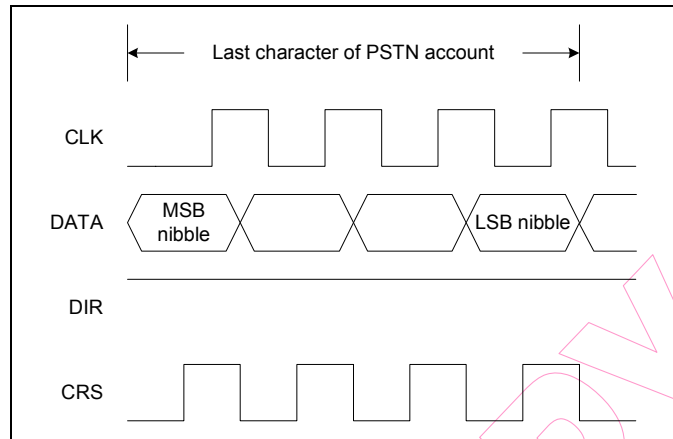

B. PSTN account coded by ASCII code

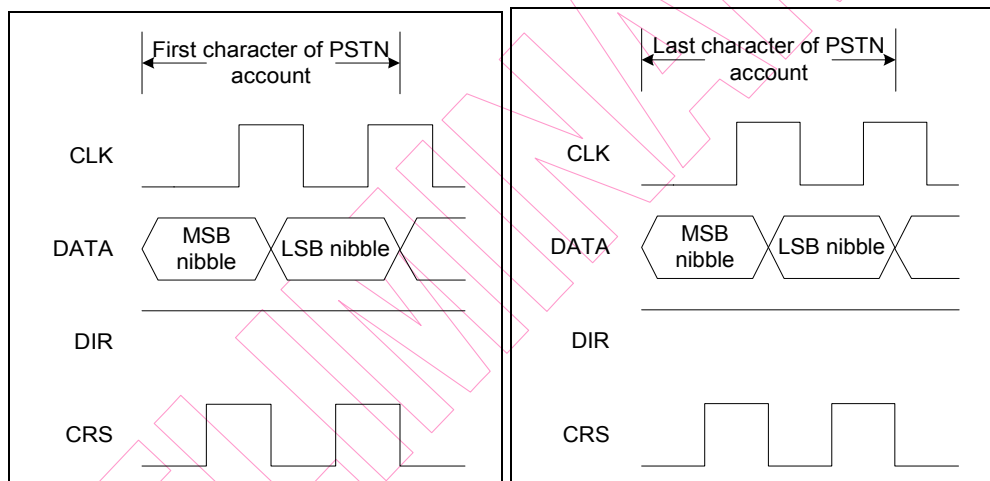

3) Telephone number

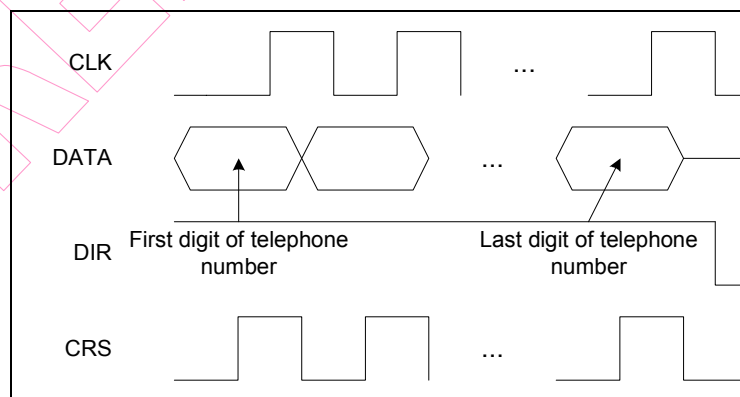

11.3.10 Download Phone Book

Format: The procedure of downloading phone book is as below

- a. start command of download phonebook:
cmd (0x8) + 0x0 + 0x0 + 0x0 + 0x0
- b. the process of downloading phonebook:
cmd (0x8) + byte number of account + nibble number of telephone number + name + telephone number
- c. stop command of download phonebook:
cmd (0x8) + 0x0 + 0x0 + 0x0 + 0x1 + 0xA

Description:

- a. PC sends Skype phone book to CID.
- b. If using Unicode, then two bytes denote one character of account; if using ASCII codes, then one byte denotes one character of account. This is dependent on user's choice.
- c. 4 bits denote a digit of telephone number.
- d. MSB significant nibble sent first.

Timing:

- 1) CMD + Data length

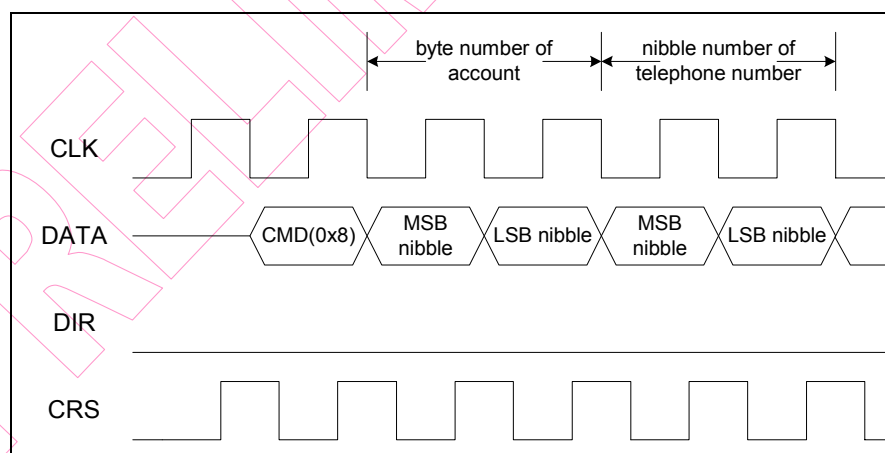

2) Skype account

A. Skype account coded by Unicode

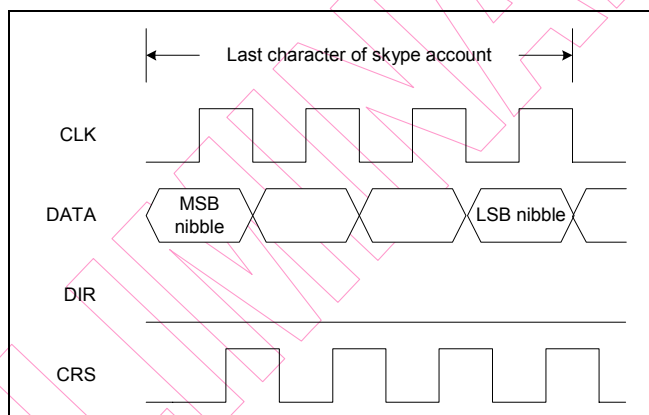
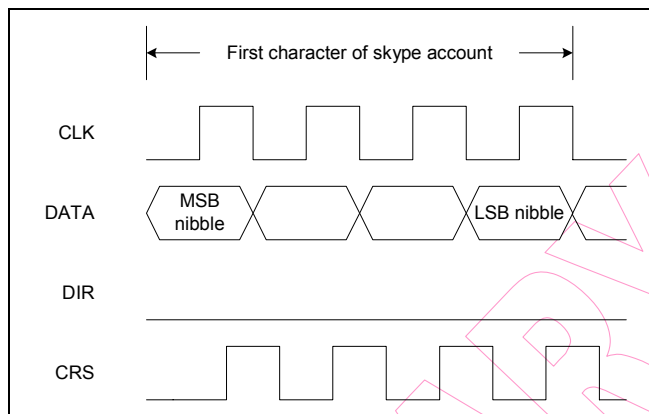

B. Skype account coded by ASCII code

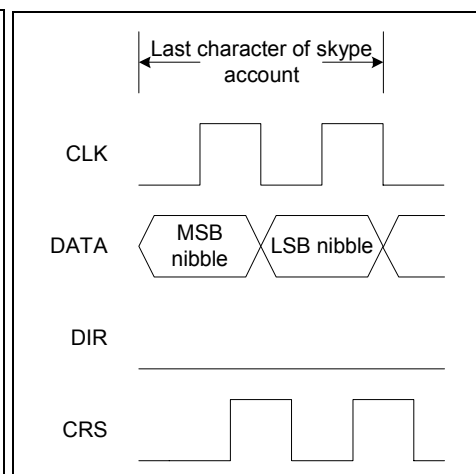
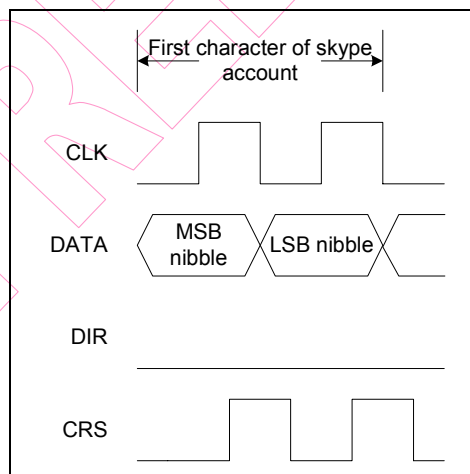

3) Telephone number

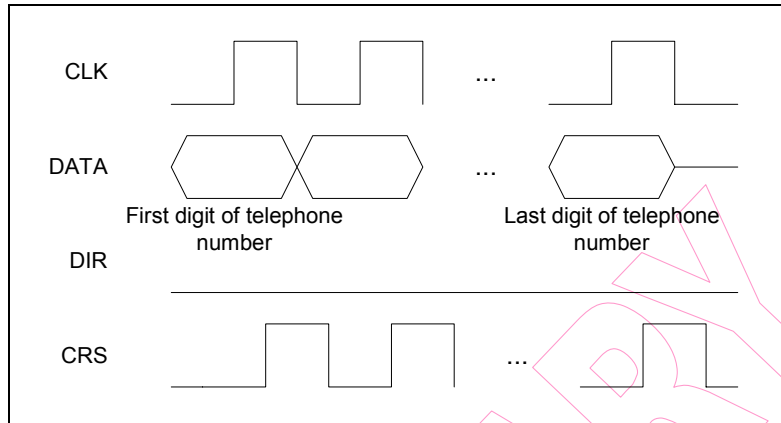

Download Phonebook Flow

1) Start command of downloading phonebook

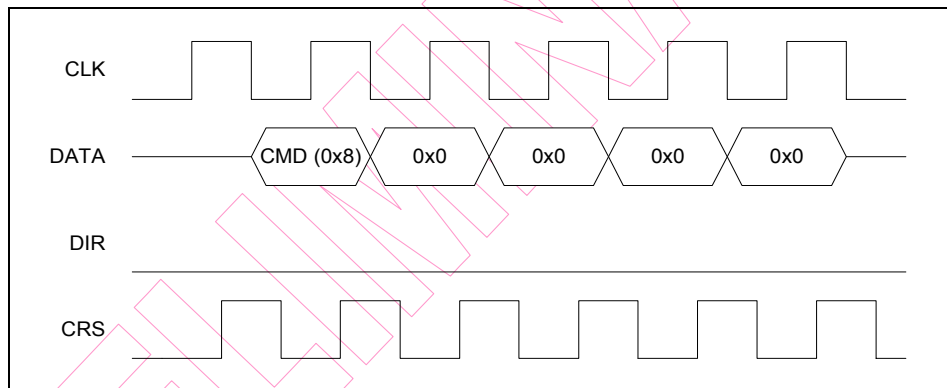

2) Download user data

2-1) User name coded by Unicode

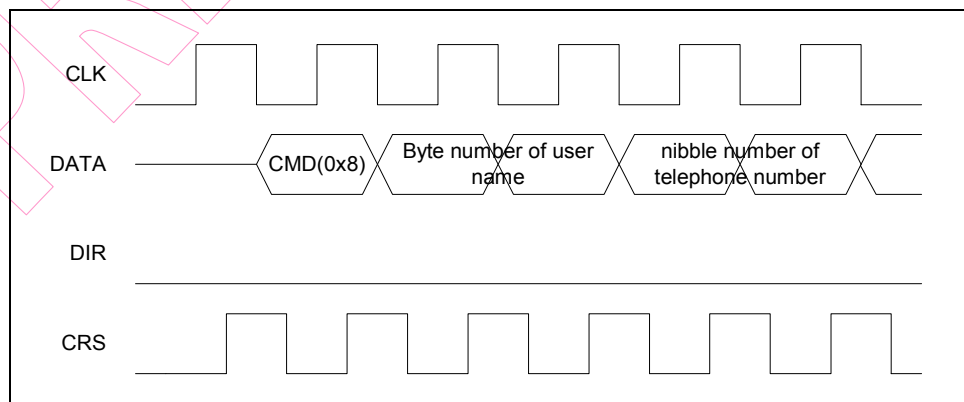

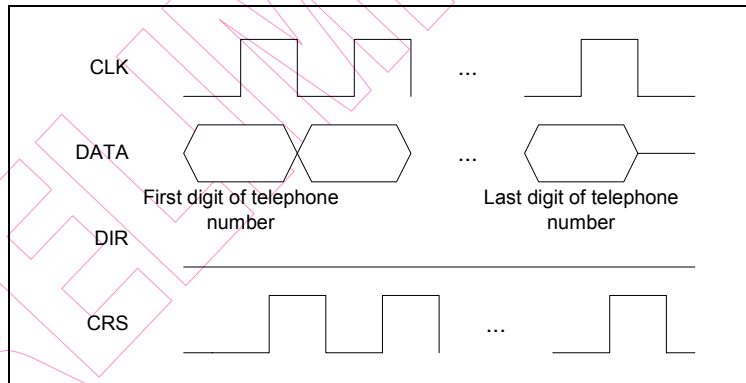
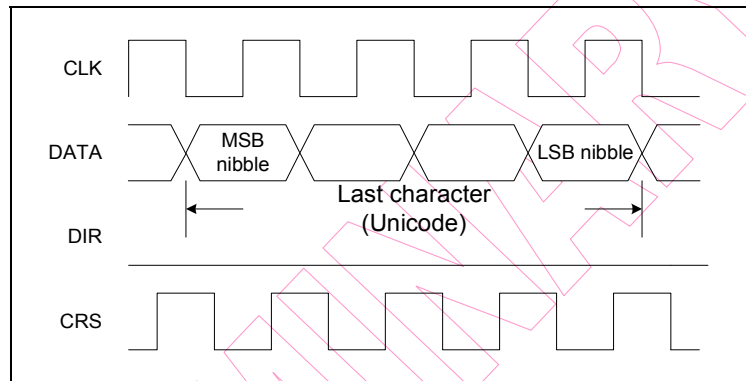
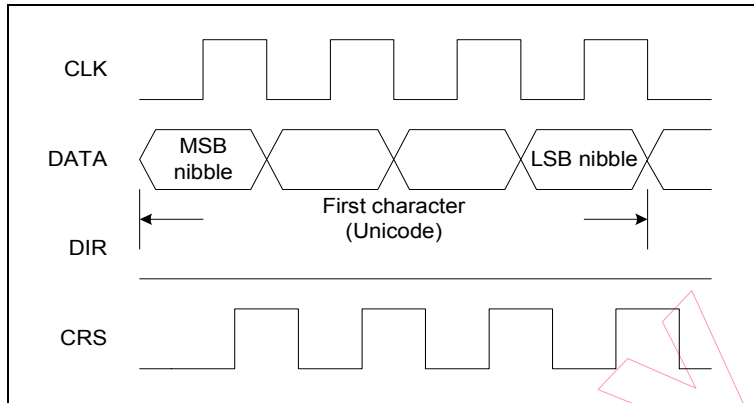

2-2) User name coded by ASCII code

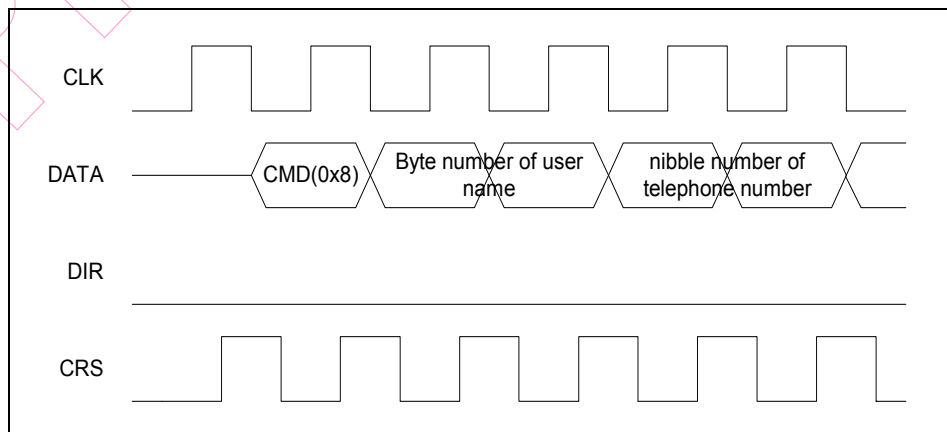

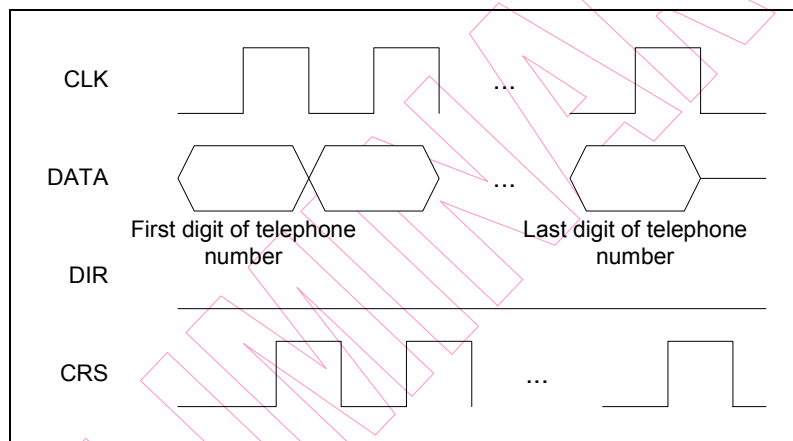
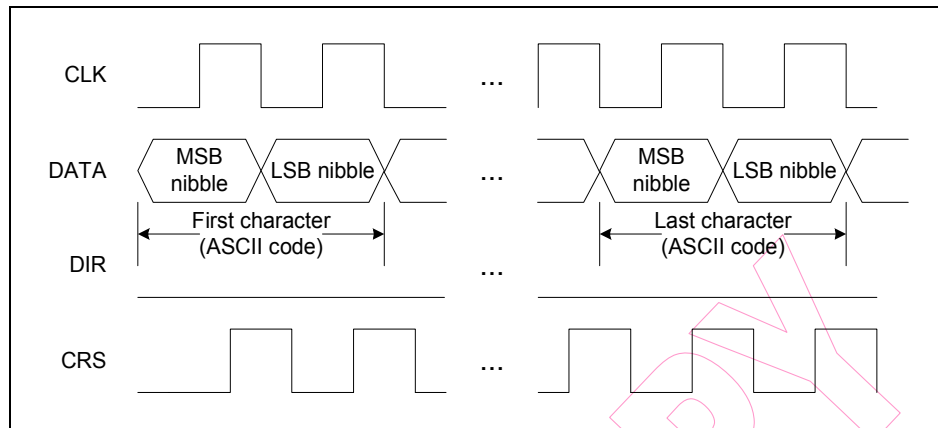

3) Stop command of download phonebook

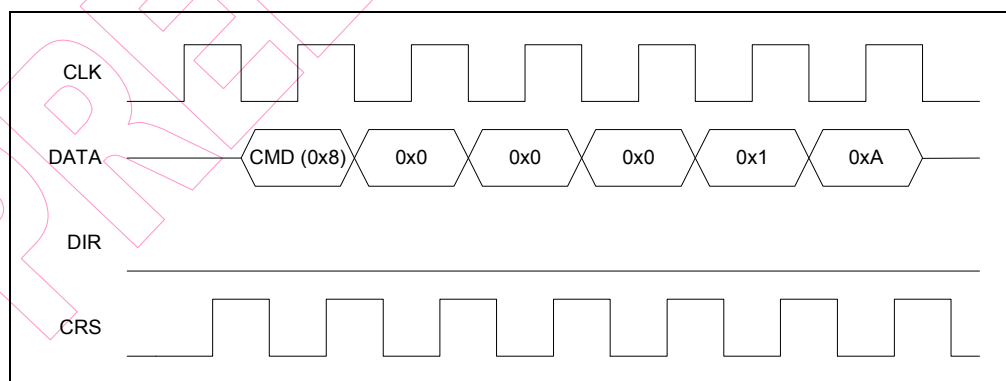



11.3.11 Dial Skype Phone

Format: cmd (0x9) + byte number of account + byte number of telephone number + account + telephone number

Description:

- a. User use the hand set to dial Skype phone
- b. If using Unicode, then two byte denote one character of account; if using ASCII codes, then one byte denotes one character of account.
- c. 4 bits denote a digit of telephone number.
- d. MSB significant nibble sent first.

Timing:

1) CMD + Data length

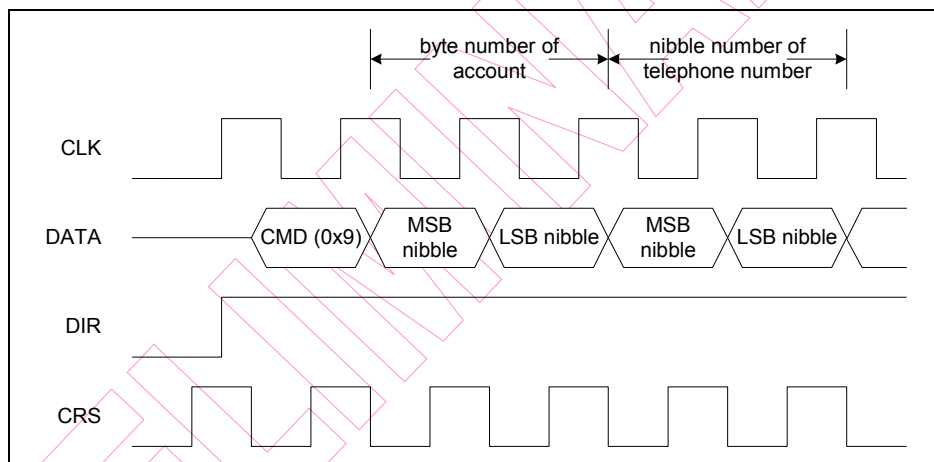

2) Skype account

A. Skype account coded by Unicode

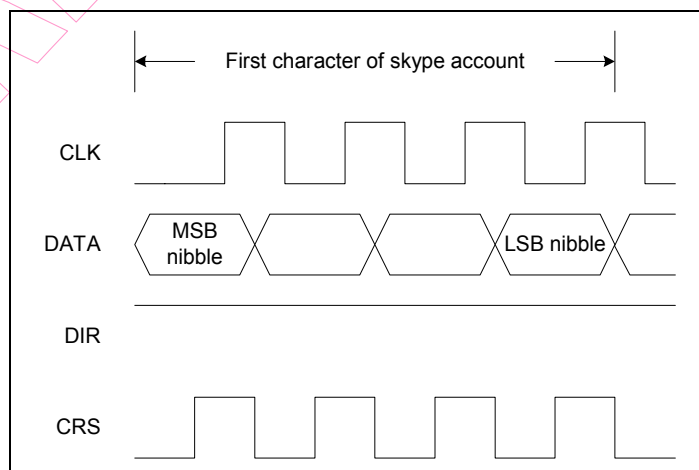

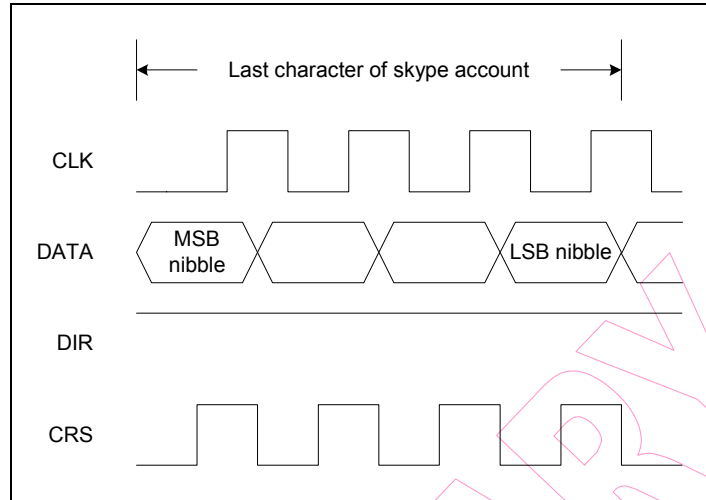

B. Skype account coded by ASCII code

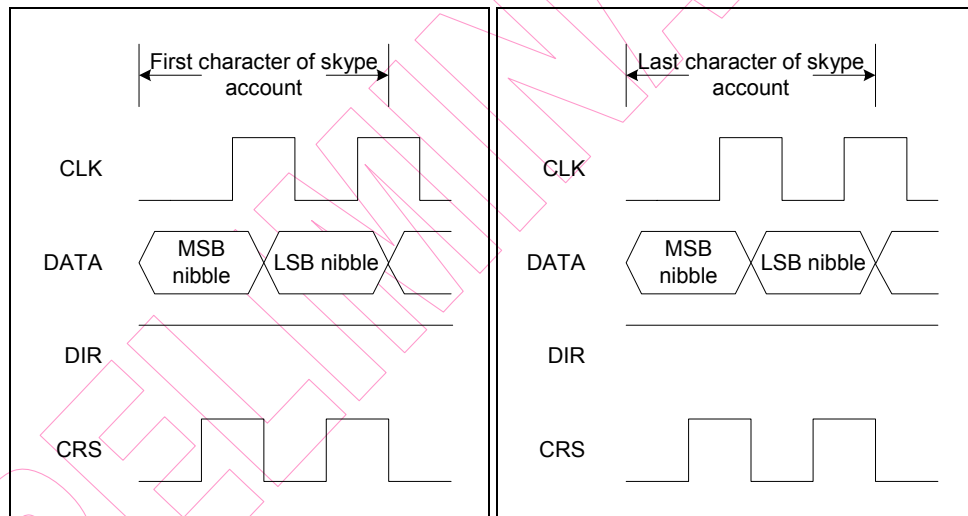

3) Telephone number

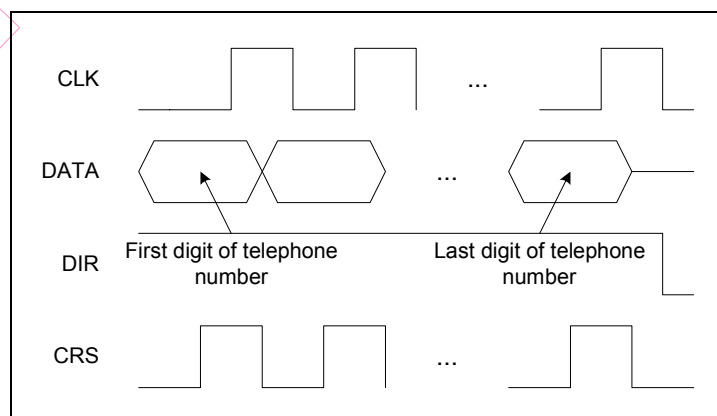

11.3.12 Download Vendor Data from PC to CID

Format: cmd (0xA~0xF) + byte number of vendor data + 0x0 (dummy nibble) + 0x0 (dummy nibble) + vendor data

Description:

- PC downloads vendor data to CID. The meaning of vendor data is dependent on user.
- The command 0xA to 0xF is used as download vendor data command
- Most significant nibble is sent first.

Timing:

1) CMD + Data length

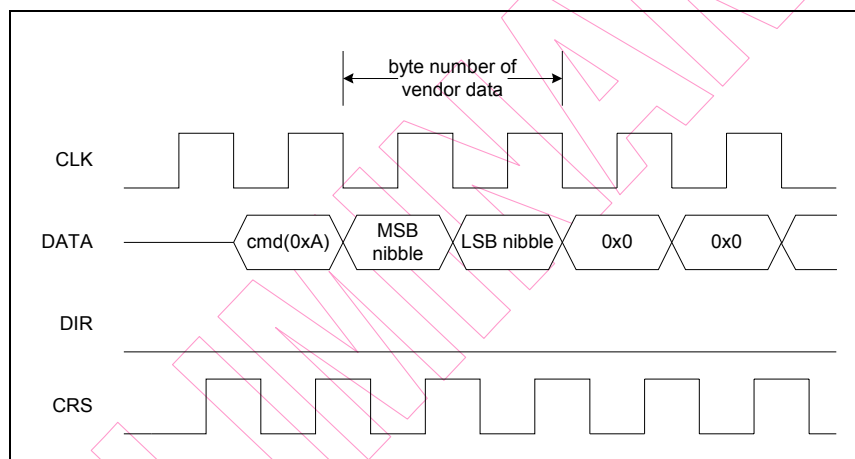

2) Vendor data

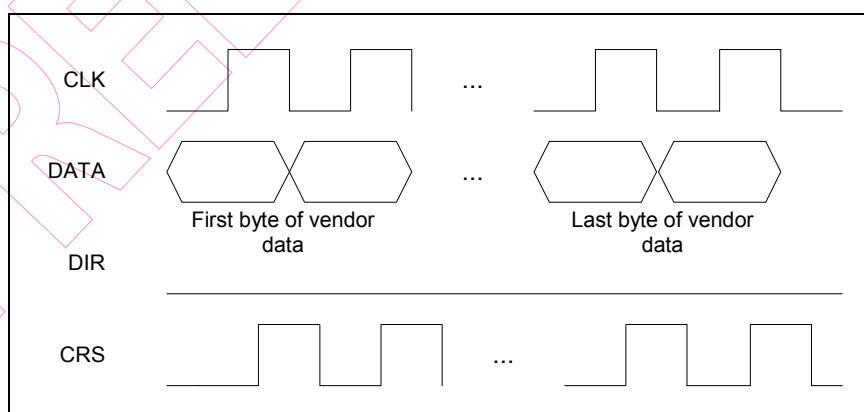

11.3.13 Upload Vendor Data from CID to PC

Format: cmd (0xA~0xF) + byte number of vendor data + 0x0 (dummy nibble) + 0x0 (dummy nibble) + 0x0 (dummy nibble) + vendor data

Description:

- PC uploads vendor data from CID. The meaning of vendor data is dependent on user.
- The command 0xA to 0xF is used as upload vendor data command.
- Most significant nibble is sent first.

Timing:

1) CMD + Data length

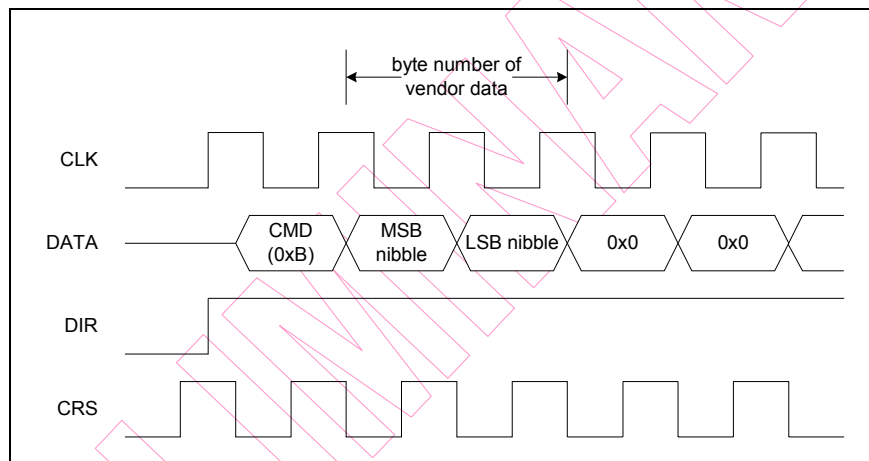

2) Vendor data

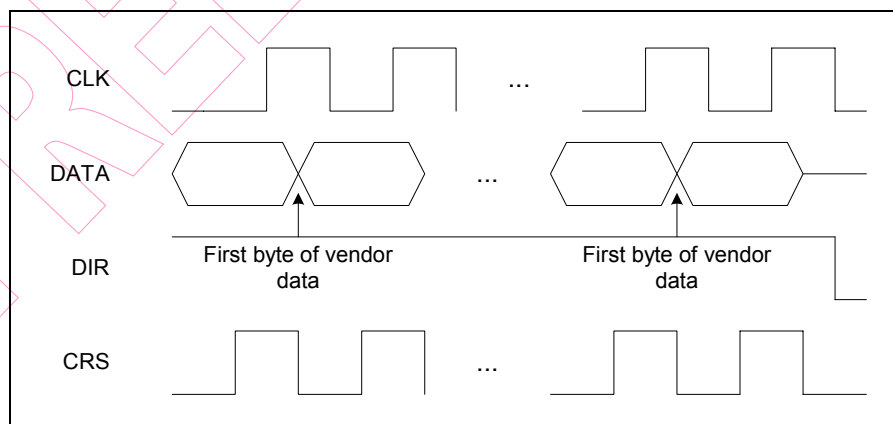

12 I²S Interface Signal

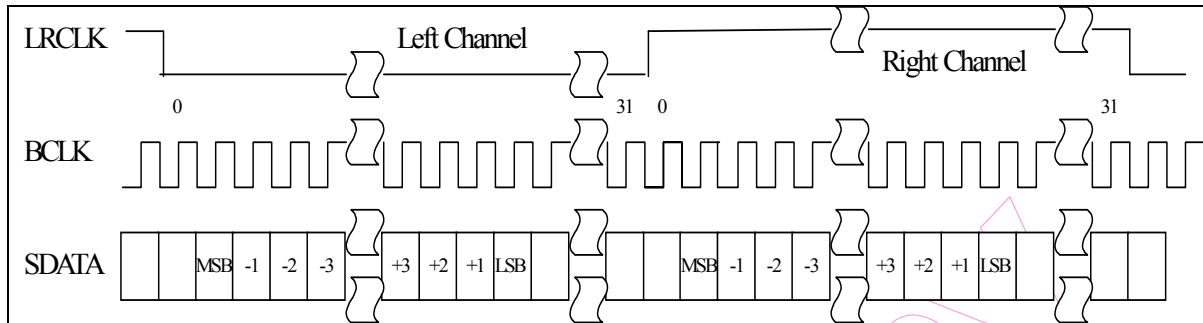

Fig. 12-1 I²S Justified Audio Stream Format

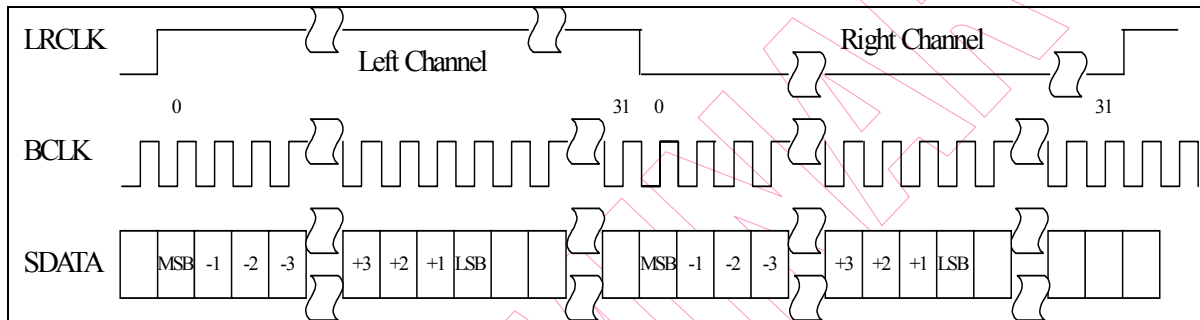

Fig. 12-2 Left Justified Audio Stream Format

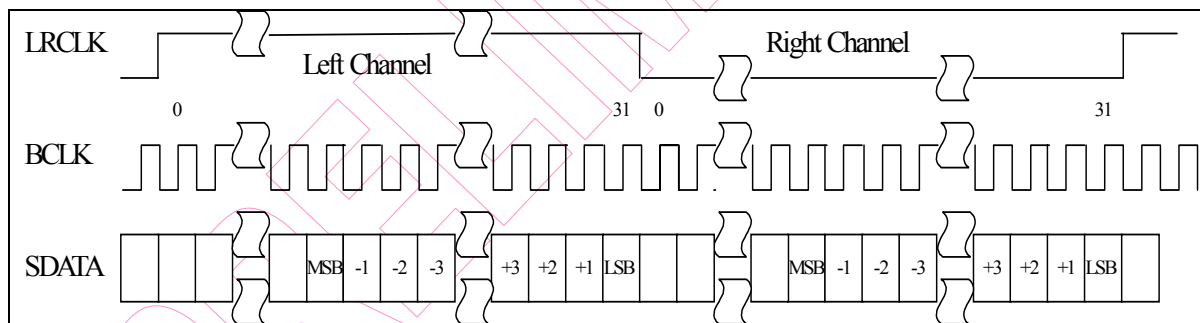

Fig. 12-3 Right Justified Audio Stream Format

The LRCLK and BCLK are derived from MCLK. The frequency ratio are as follows:

$$\text{MCLK} : \text{LRCLK} : \text{BCLK} = 256 : 1 : 64$$

The frequency of LRCLK equals the sampling rate 48kHz, 44.1kHz, 32kHz or 8kHz based on FS_SEL0 and FS_SEL1 pins status.

13 Package

Symbol	Min	Normal	Max
A			1.60
A1	0.05		0.15
A2	1.35	1.40	1.45
b	0.17	0.22	0.27
c	0.09		0.20
D1	9.00BCS		
D	7.00BSC		
E1	9.00BSC		
E	7.00BSC		
e	0.50BSC		
L	0.45	0.60	0.75
L1	1.00 REF		
θ	0°	3.5°	7°

義隆電子股份有限公司 ELAN MICROELECTRONICS CORPORATION			TITLE: LQFP-48(7*7) MM FOOTPRINT 2.0mm PACKAGE OUTLINE DIMENSION	
DWG NO: POD-058			File : LQFP48	Edition: A
	Name	Date		
Draw	鍾玉真	92/10/23		
Check	吳進富	92/10/23		
Approved	蔡建文	92/10/23		
			Unit : mm	
			Scale: Free	
			Material:	
			Sheet: 1 of 1	

PRELIMINARY