

eKT8100A

Capacitive Touch Pad Controller

Product Specification

DOC. VERSION 1.3

ELAN MICROELECTRONICS CORP.

November 2006



Trademark Acknowledgments:

IBM is a registered trademark and PS/2 is a trademark of IBM.

Windows is a trademark of Microsoft Corporation.

ELAN and ELAN logo  are trademarks of ELAN Microelectronics Corporation.

Copyright © 2006 by **ELAN Microelectronics Corporation**

All Rights Reserved

Printed in Taiwan

The contents of this specification are subject to change without further notice. ELAN Microelectronics assumes no responsibility concerning the accuracy, adequacy, or completeness of this specification. ELAN Microelectronics makes no commitment to update, or to keep current the information and material contained in this specification. Such information and material may change to conform to each confirmed order.

In no event shall ELAN Microelectronics be made responsible for any claims attributed to errors, omissions, or other inaccuracies in the information or material contained in this specification. ELAN Microelectronics shall not be liable for direct, indirect, special incidental, or consequential damages arising from the use of such information or material.

The software (if any) described in this specification is furnished under a license or nondisclosure agreement, and may be used or copied only in accordance with the terms of such agreement.

ELAN Microelectronics products are not intended for use in life support appliances, devices, or systems. Use of ELAN Microelectronics product in such applications is not supported and is prohibited.

NO PART OF THIS SPECIFICATION MAY BE REPRODUCED OR TRANSMITTED IN ANY FORM OR BY ANY MEANS WITHOUT THE EXPRESSED WRITTEN PERMISSION OF ELAN MICROELECTRONICS.



ELAN MICROELECTRONICS CORPORATION**Headquarters:**

No. 12, Innovation Road 1
Hsinchu Science Park
Hsinchu, TAIWAN 30077
Tel: +886 3 563-9977
Fax: +886 3 563-9966
<http://www.emc.com.tw>

Hong Kong:

Elan (HK) Microelectronics Corporation, Ltd.
Flat A, 19F., World Tech Centre
95 How Ming Street, Kwun Tong
Kowloon, Hong Kong
Tel: +852 2723-3376
Fax: +852 2723-7780
elanhk@emc.com.hk

USA:

Elan Information Technology Group (U.S.A.)
1821 Saratoga Ave., Suite 250
Saratoga, CA 95070
USA
Tel: +1 408 366-8225
Fax: +1 408 366-8220

Europe:

Elan Microelectronics Corp. (Europe)
Siewerdstrasse 105
8050 Zurich, SWITZERLAND
Tel: +41 43 299-4060
Fax: +41 43 299-4079
<http://www.elan-europe.com>

Shenzhen:

Elan Microelectronics Shenzhen, Ltd.
SSMEC Bldg., 3F, Gaoxin S. Ave.
Shenzhen Hi-Tech Industrial Park
Shenzhen, Guangdong, China
Tel: +86 755 2601-0565
Fax: +86 755 2601-0500

Shanghai:

Elan Microelectronics Shanghai, Ltd.
23/Bldg. #115 Lane 572, Bibo Road
Zhangjiang Hi-Tech Park
Shanghai, China
Tel: +86 21 5080-3866
Fax: +86 21 5080-4600



Contents

1	Introduction	1
2	Features	1
3	Three-Mode State Transition	2
4	Interface Description	3
4.1	UART Interface	3
4.2	SPI Interface.....	5
5	Pin Assignment	8
6	Pin Description	10
7	Timing Description	13
8	Special Pin Description	13
8.1	Interface Selection Pin	13
8.2	/INT Pin.....	14
8.3	I/O-Output Pin.....	15
9	Electrical Characteristic	17
9.1	Absolute Maximum Ratings	17
9.2	DC Electrical Characteristic	17
9.3	AC Electrical Characteristic.....	17
10	Application Circuit	18
10.1	Mode1 (Button mode)	18
10.1.1	LQFP 64	18
10.1.2	QFN 40	19
10.2	Mode 2 (Single Scroll Mode).....	20
10.3	Mode 3 (Double Scroll Mode)	21
11	Protocol Description	22
11.1	Command Description	22
11.1.1	Packet Synchronous (Host to Device, UART Mode Only)	22
11.1.2	Packet Hello (Device to Host; Mode 1 Only).....	22
11.1.3	Packet Hello (Device to Host; Mode 2 and Mode 3 Only).....	22
11.1.4	Packet ID #6 (Device to Host; Mode 1)	23
11.1.5	Packet ID #8 (Device to Host; Mode 2 and Mode 3).....	24
11.1.6	Packet ID #2 (Device to Host)	25
11.1.7	Packet ID #3 (Host to Device).....	26
11.1.8	Packet ID #4 (Host to Device).....	26
11.2	Register Description.....	26
11.2.1	Register Number = 0, Read F/W Version (Read Only)	26
11.2.2	Register Number = 1, Read Button Status (Read Only)	27
11.2.3	Register Number = 2, Read S1 Position (Read Only)	28



11.2.4 Register Number = 3, Read S2 Position (Read Only)28

11.2.5 Register Number = 4, TP Sensitivity Setting(R/W)29

11.2.6 Register Number = 5, TP Power State Setting(R/W)29

11.2.7 Register Number = 6, Multi-Finger Function Setting(R/W)30

11.2.8 Register Number = 13, TP Cold –Reset (Write Only)30

11.2.9 Register Number = 14, TP Report Rate Setting(R/W)30

11.2.10 Register Number = 15, Read Firmware ID (Read Only)31

12 Package Specification.....32

12.1 LQFP64 32

12.2 QFN40 33

Specification Revision History

Doc. Version	Revision Description	Date
1.0	Preliminary version	2006/08/04
1.1	Delete I ² C interface	2006/8/28
1.2	1. Modified the Button mode – sensor capacitance range (5pF~15pF). 2. Modified the UART/SPI system diagram and added some timing description.	2006/10/17
1.3	Modified operating temperature	2006/11/01
1.4	1. Modified F/W version description. 2. Modified F/W ID description.	2006/11/02
1.5	Add SPI timing description. (Page.6)	2006/12/20

1 Introduction

The eKT8100A is a low-cost single chip solution for capacitive touch pad. It is an 8-bit RISC microcontroller with Serial Peripheral Interface (SPI) and Universal Asynchronous Receiver / Transmitter (UART).

The eKT8100A has three modes of application – **First**, it supports **Full button mode**, which provides only virtual buttons information at the same time. **Second**, it supports **Single scroll bar mode**, which provides scroll bar (S1) absolute position information and virtual buttons information at the same time. **Third**, it supports **Double scroll bar mode**, which provide 1st scroll bar (S1) absolute position information, 2nd scroll bar (S2) absolute position information and virtual buttons information at the same time. The customer can use these modes to develop their system control.

The capacitive touch pad sensor is covered with a plastic case. The typical thickness of the plastic is 1.0mm ~ 1.5mm. It can also auto calibrate the parameters for a wide range of capacitance on the touch pad sensor (10pF~50pF). In Full button mode, the range of capacitance on the touch pad sensor (5pF~15pF). The system controller converts finger position data to either scrolling data or button presses, depending on finger location and human interface context.

2 Features

- Operating voltage: 2.6V ~ 5.5V, Ripple < 100mVpp
- Power-on reset time: Stable time for operating < 150ms, the touch pad will send "Packet Hello" after initialization
- Interface features: Serial Peripheral Interface (SPI) / Universal Asynchronous Receiver Transmitter (UART)
- Operating mode:

Mode	Description	Current
Normal	<ol style="list-style-type: none"> 1. Finger on touch pad 2. Higher scan rate 	<1.5 mA
Idle	<ol style="list-style-type: none"> 1. Finger leaves touch pad 2. Lower scan rate 3. Scan rate in idle mode can be adjusted by changing the external RC value. 	<200 μ A
Sleep	No scan	<20 μ A

- Application mode:
 - Mode 1 (Full button mode):** maximum support for 18 virtual buttons
 - Mode 2 (Single scroll mode):** one scroll bar + 6 virtual buttons
 - Mode 3 (Double scroll mode):** two scroll bars + 8 virtual buttons

- Useful Information

S1 absolute position information and S2 absolute position information can be used for scrolling function.

Virtual buttons information can be used for function controls (like physical buttons).

- Sensitivity: Sensitivity can be adjusted from 0 to 6 for different thickness of the plastic cover. The default label of Mode 1 / Mode 2 is “2”. Moreover, the default label of Mode 3 is “3”.

- Package type: LQFP64 / QFN40

3 Three-Mode State Transition

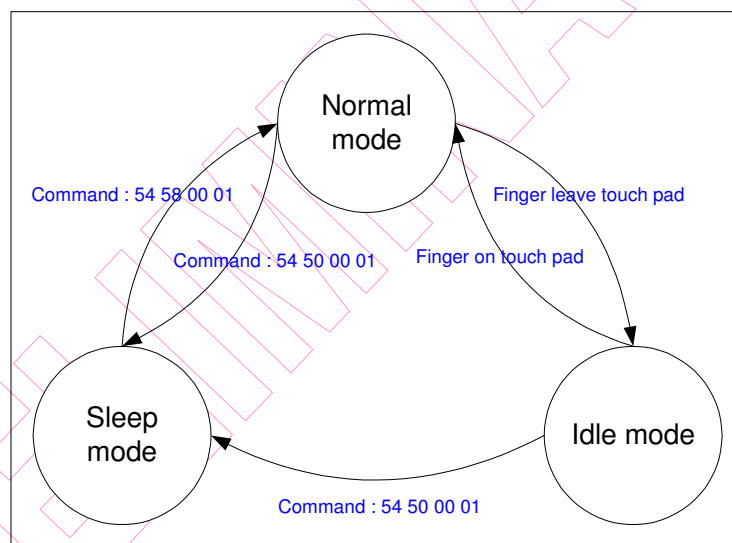

4 Interface Description

4.1 UART Interface

The UART interface parameter is 9600 baud rate with no parity check and 8 bits in length. The following diagram shows the system functional blocks including UART interface. The controller detects an object on the touch pad sensor and sends the information to host. The SDO_TX and SDI_RX signals must be pulled high with 20K Ω resistors on the host end. The host can send commands to eKT8100A via the SDI_RX pin and the touchpad controller will send the position information to the host via the SDO_TX pin.

In normal mode operation, the touchpad controller will send continuously reports to the host via the SDO_TX. In case the host is in sleep mode, a GPIO (general purpose I/O) pin of host can be used for wake-up. After wake-up of the host, the host has to send "Packet Synchronous" to the touchpad controller for interface synchronization.

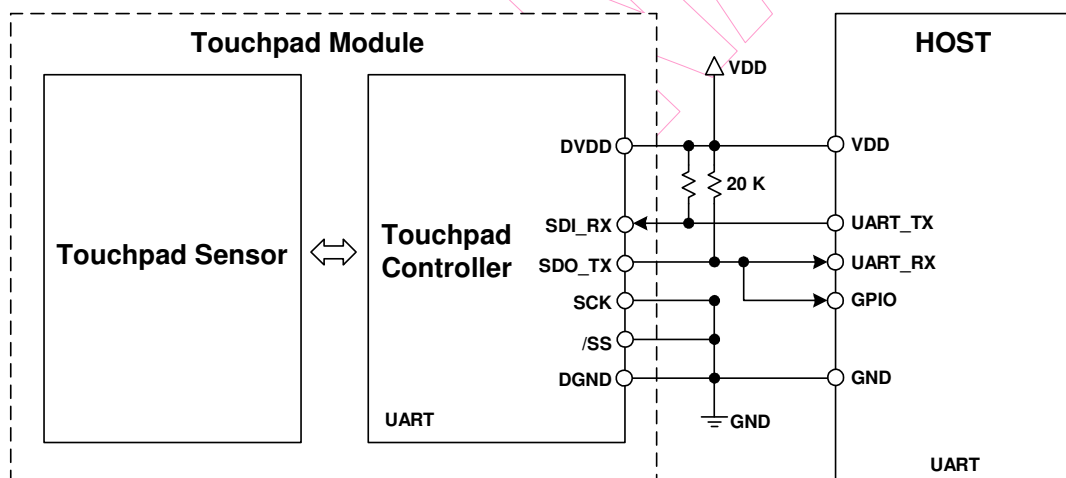

Fig. 4-1 System Block Diagram and UART Interface

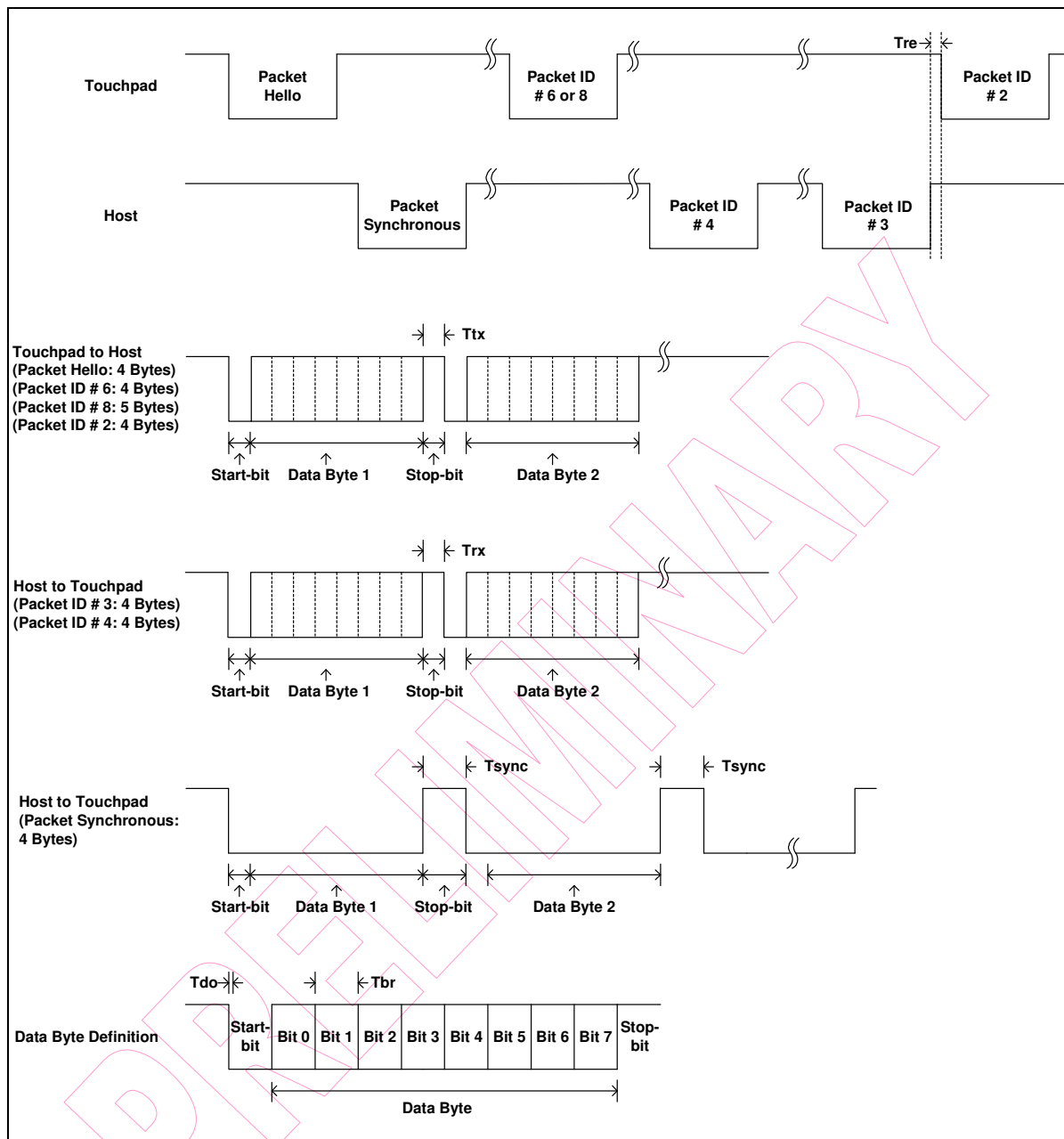

Fig. 4-2 Timing diagram for UART interface mode

The timing conditions are as follows:

- Tre: 56 μ s (typical), Touchpad response time after the host send command inquiring information from eKT8100A
- Ttx: 56 μ s (typical), Stop-bit timing for touchpad to host communication
- Trx: 104 μ s (Minimum), Stop-bit timing for host to touchpad communication
- Tsync: 250 μ s (Minimum), Stop-bit timing after Packet Synchronous
- Tdo: 100 ns (Maximum), Start-bit falling edge timing from high to low
- Tbr: 104 μ s (Typical), Timing of one bit (include of Start-bit)

4.2 SPI Interface

The SPI interface parameter is 23kHz, 8 bits in length, MSB first; host as slave. The following diagram shows the system functional blocks including SPI. The controller detects an object on the touch pad sensor and sends the information to host.

In SPI interface, the signals should be pulled high with 20KΩ resistors on the host end. Although this controller is a master device, but the host can send commands to the touch pad by driving the /SS pin low.

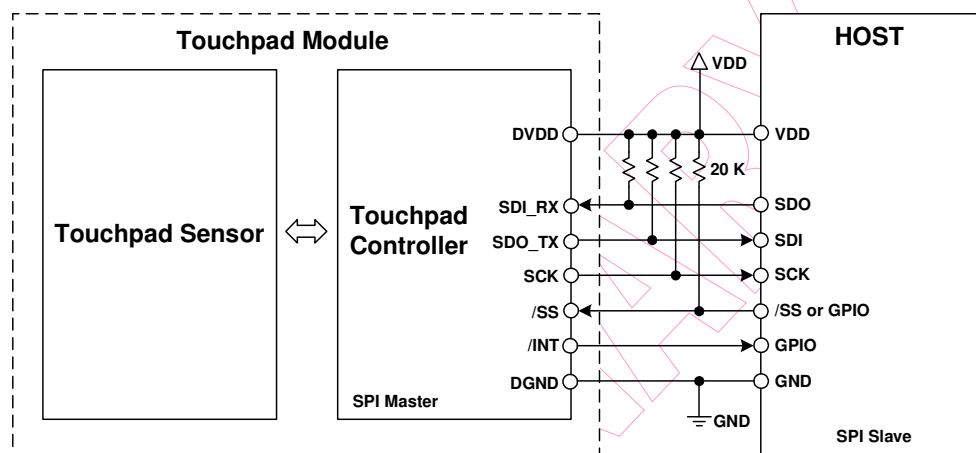

Fig. 4-3 System Block Diagram and SPI Interface

The timing of SPI master mode is defined below:

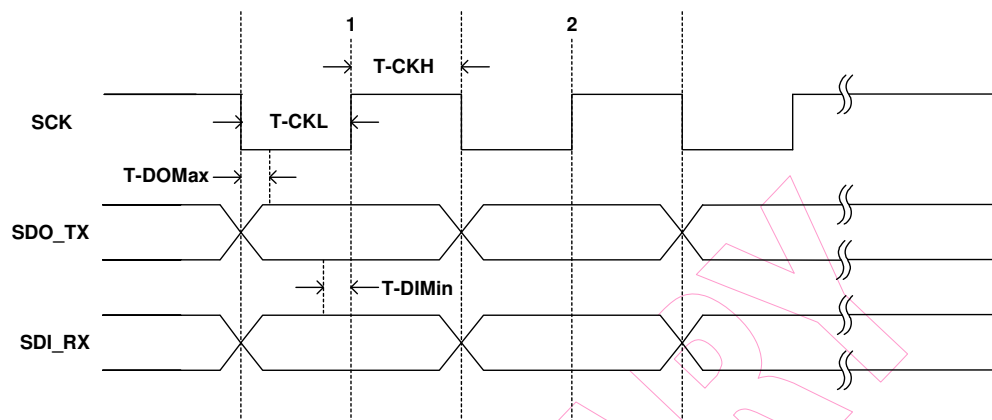

Fig. 5-7 Timing diagram for SPI master mode

The timing conditions are as follows:

- T- CKH: 20.3 μ s (\pm 10%), Time of Clock High
- T- CKL: 20.3 μ s (\pm 10%), Time of Clock Low
- T- DOMax: 250 ns, Maximum prepare time to send Data out
- T- DIMin: 250 ns, Minimum prepare time to latch Data in

When the eKT8100A wants to send reports to the host, it will pull-low the /INT signal. The touchpad controller will start to send the first clock and data to the host after the time of "TTr_Start_0" (~ 100 μ s). The interval time between each clock byte is "TByte_Interval" (~ 50 μ s). After the report transmission, the touchpad controller will pull-high again the /INT signal (see Fig. 4-5).

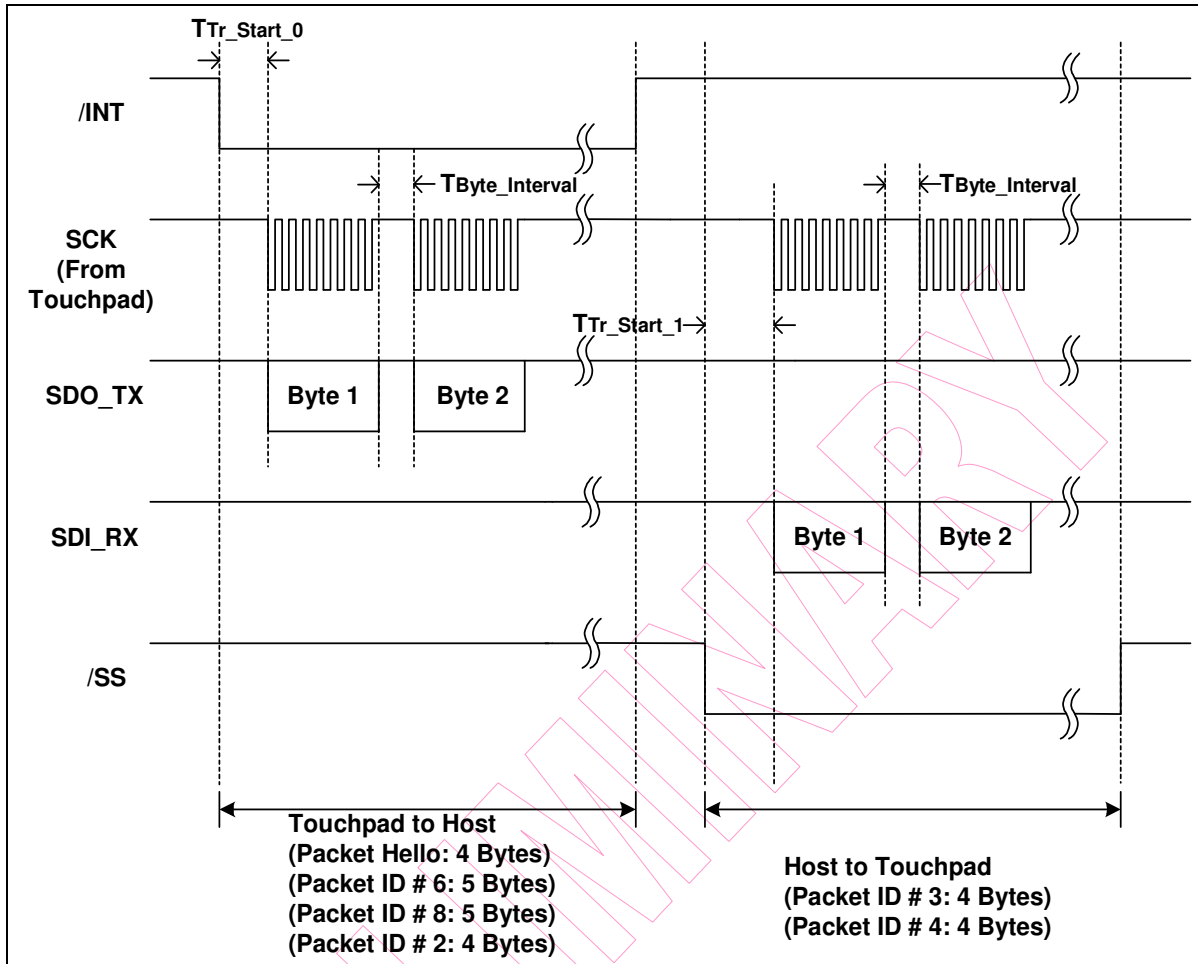

Fig. 4-5 Data transmission and Receiving in SPI master mode

Although the eKT8100A is the SPI master, the host can send commands to the touchpad controller by driving /SS pin to low. When the touchpad controller detects the low state of the /SS pin, it will start to send the first clock to the host after "TTr_Start_1" (~ 250 μ s). The interval time between each clock byte is "TByte_Interval" (~ 50 μ s) (see Fig. 4-5).

5 Pin Assignment

■ LQFP64

Dimension: 7mm × 7mm

Thickness: 1.4 mm

Green Package

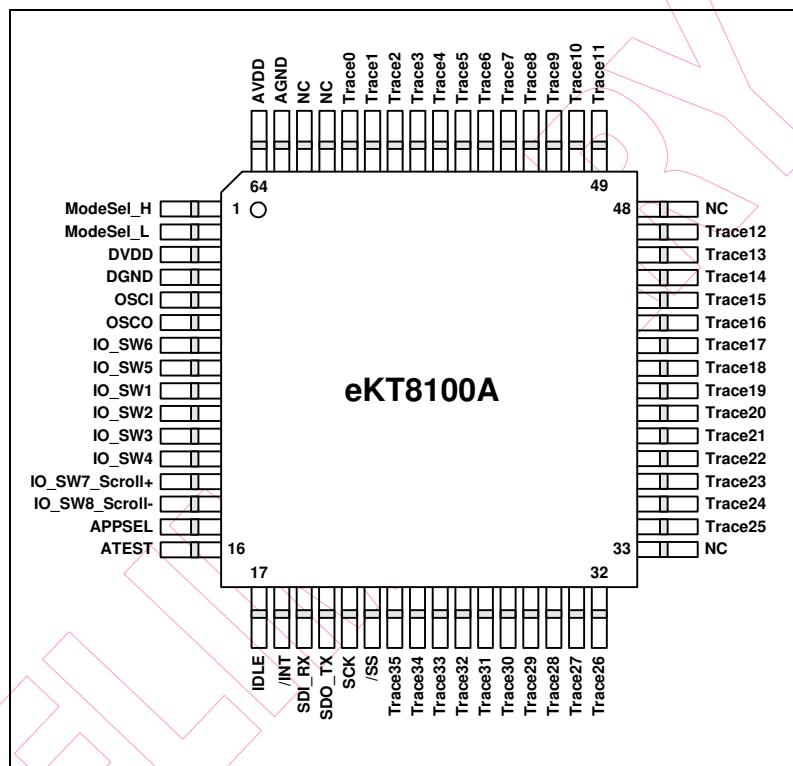

■ QFN40

Dimension: 6mm × 6mm

Thickness: 0.8mm

Green Package

Only used in Mode 1 (Full button mode) and supports a maximum of 18 buttons.

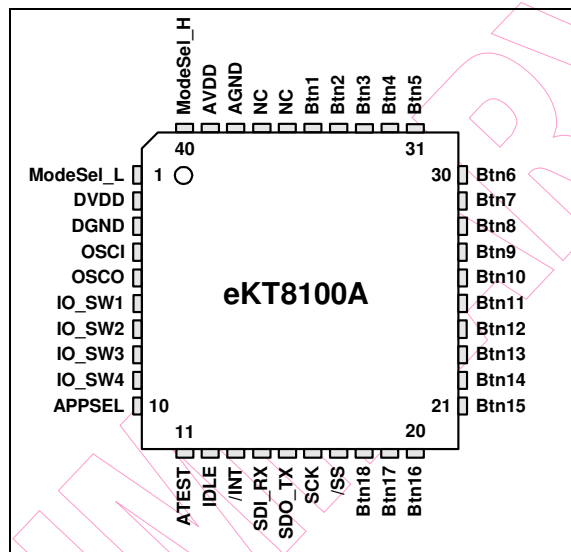

6 Pin Description

■ LQFP64

Pin No.	Symbol	Function Description
1	ModeSel_H	Mode selection pin.
2	ModeSel_L	ModeSel_H=0, ModeSel_L=0 → Mode 1 (Full button mode) ModeSel_H=0, ModeSel_L=1 → Mode 2 (Single scroll mode) ModeSel_H=1, ModeSel_L=1 → Mode 3 (Double scroll mode)
3	DVDD	Power supply input. A decoupling capacitor is needed between DVDD and DGND.
4	DGND	Digital block's ground.
5	OSCI	6MHz ± 10% RC oscillator input with external resistor 47KΩ ± 1% tied to DVDD.
6	OSCO	Tied to DVDD
7	IO_SW6	Simulate switch signal from virtual button (SW6). Normal High and active low.
8	IO_SW5	Simulate switch signal from virtual button (SW5). Normal High and active low.
9	IO_SW1	Simulate switch signal from virtual button (SW1). Normal High and active low.
10	IO_SW2	Simulate switch signal from virtual button (SW2). Normal High and active low.
11	IO_SW3	Simulate switch signal from virtual button (SW3). Normal High and active low.
12	IO_SW4	Simulate switch signal from virtual button (SW4). Normal High and active low.
13	IO_SW7_Scroll+	1. Mode1 (full button mode): Simulate switch signal from virtual button (SW7). Normal High and active low. 2. Mode2/Mode3 (single/double scroll bar mode): Simulate switch signal from scroll bar1 (S1) positive moving (Scroll+). Normal High and active low.
14	IO_SW8_Scroll-	1. Mode1 (full button mode): Simulate switch signal from virtual button (SW8). Normal High and active low. 2. Mode2/Mode3 (single/double scroll bar mode): Simulate switch signal from scroll bar1 (S1) negative moving (Scroll-). Normal High and active low.
15	APPSEL	Connected to ATEST
16	ATEST	Connected to APPSEL
17	IDLE	Idle Mode control. Scan rate in idle mode can be adjusted by changing the RC value.
18	/INT	INT signal. - If "INT"=0, eKT8100A has data packet to transmit - If "INT"=1, eKT8100A has no data packet to transmit
19	SDI_RX	1. RX pin in UART mode pulled high with 20KΩ resistors. 2. SDI pin in SPI mode pulled high with 20KΩ resistors.
20	SDO_TX	1. TX pin in UART mode pulled high with 20KΩ resistors. 2. SDOpin in SPI mode pulled high with 20KΩ resistors.
21	SCK	1. SCK pin in SPI mode. 2. UART Mode select Pin 1.



Pin No.	Symbol	Function Description
22	/SS	1. Host command pin in SPI mode. 2. UARTMode select Pin 2.
23	Trace35	Trace35
24	Trace34	Trace34
25	Trace33	Trace33
26	Trace32	Trace32
27	Trace31	Trace31
28	Trace30	Trace30
29	Trace29	Trace29
30	Trace28	Trace28
31	Trace27	Trace27
32	Trace26	Trace26
34	Trace25	Trace25
35	Trace24	Trace24
36	Trace23	Trace23
37	Trace22	Trace22
38	Trace21	Trace21
39	Trace20	Trace20
40	Trace19	Trace19
41	Trace18	Trace18
42	Trace17	Trace17
43	Trace16	Trace16
44	Trace15	Trace15
45	Trace14	Trace14
46	Trace13	Trace13
47	Trace12	Trace12
49	Trace11	Trace11
50	Trace10	Trace10
51	Trace9	Trace9
52	Trace8	Trace8
53	Trace7	Trace7
54	Trace6	Trace6
55	Trace5	Trace5
56	Trace4	Trace4
57	Trace3	Trace3
58	Trace2	Trace2
59	Trace1	Trace1
60	Trace0	Trace0
63	AGND	Analog block's ground
64	AVDD	2.4V regulator output. A decoupling capacitor is needed between AVDD and AGND.
33, 48, 61, 62	NC	-

■ QFN40

Pin No.	Symbol	Function Description
40	ModeSel_H	Mode selection pin.
1	ModeSel_L	ModeSel_H=0, ModeSel_L=0 → Mode 1 (Full button mode) ModeSel_H=0, ModeSel_L=1 → Mode 2 (Single scroll mode) ModeSel_H=1, ModeSel_L=1 → Mode 3 (Double scroll mode)
2	DVDD	Power supply input. A decoupling capacitor is needed between DVDD and DGND.
3	DGND	Connect to GND
4	OSCI	6MHz ± 10% RC oscillator input with 47kΩ ± 1% external resistor tied to DVDD.
5	OSCO	Tied to DVDD pin
6	IO_SW1	Simulate switch signal from virtual button (SW1). Normal High and active low.
7	IO_SW2	Simulate switch signal from virtual button (SW2). Normal High and active low.
8	IO_SW3	Simulate switch signal from virtual button (SW3). Normal High and active low.
9	IO_SW4	Simulate switch signal from virtual button (SW4). Normal High and active low.
10	APPSEL	Connected to ATEST
11	ATEST	Connected to APPSEL
12	IDLE	Idle Mode control Scan rate in idle mode can be adjusted by changing the RC value.
13	/INT	INT signal. - If "INT"=0, eKT8100A has data packet to transmit - If "INT"=1, eKT8100A has no data packet to transmit
14	SDI_RX	1. RX pin in UART mode pulled high with 20KΩ resistors. 2. SDI pin in SPI mode pulled high with 20KΩ resistors.
15	SDO_TX	1. TX pin in UART mode pulled high with 20KΩ resistors. 2. SDO pin in SPI mode pulled high with 20KΩ resistors.
16	SCK	1. SCK pin in SPI mode. 2. UART Mode select pin1.
17	/SS	1. Host command pin in SPI mode. 2. UART Mode select Pin 2.
18	Btn18	Btn18
19	Btn17	Btn17
20	Btn16	Btn16
21	Btn15	Btn15
22	Btn14	Btn14
23	Btn13	Btn13
24	Btn12	Btn12
25	Btn11	Btn11
26	Btn10	Btn10
27	Btn9	Btn9
28	Btn8	Btn8
29	Btn7	Btn7
30	Btn6	Btn6
31	Btn5	Btn5
32	Btn4	Btn4
33	Btn3	Btn3
34	Btn2	Btn2
35	Btn1	Btn1
38	AGND	Analog block's ground.
39	AVDD	2.4V regulator output. A decoupling capacitor is needed between AVDD and AGND.
36, 37	NC	-

7 Timing Description

A. Power-on reset: After the touch pad is powered up, this controller will do initialization. The initialization includes MCU and analog parameter initialization. After the initial process, it will send Packet Hello to let the host know that the touch pad is ready to work. Fig. 7-1 shows the process after power up. T_{PowerUp} is between 20ms and 100ms.

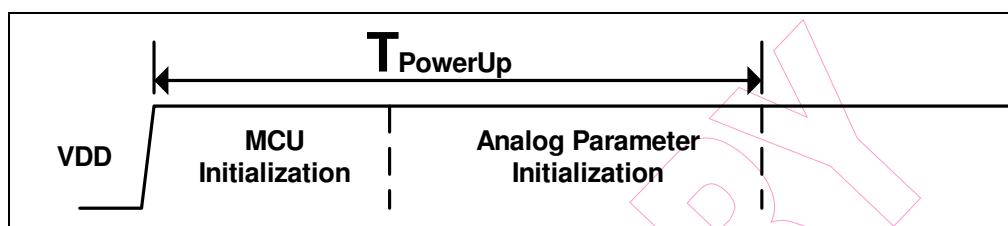

Fig. 7-1 Power-on Reset Timing Diagram

B. Wakeup: Fig 7-2 below shows the eKT8100A wake-up time from deep sleep mode.

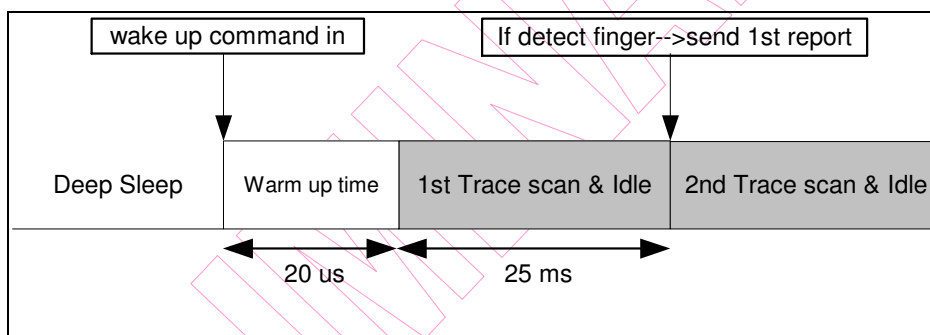

Fig. 7-2 Wake-up Timing from Deep Sleep Mode

8 Special Pin Description

8.1 Interface Selection Pin

Interface	SPI Mode	UART Mode
SCK	High	Low
/SS	High	Low

For each interface, the valid pins are:

1. SPI mode: /SS, SCK, SDO_TX, and SDI_RX
2. UART mode: SDO_TX, SDI_RX

8.2 /INT Pin

The /INT state is always high. If the eKT8100A detects a scroll position or the button state has changed, it will pull the /INT signal low first. After 100 μs (min), the eKT8100A will send a response data, and after 100 μs (max), the eKT8100A will pull the /INT signal high.

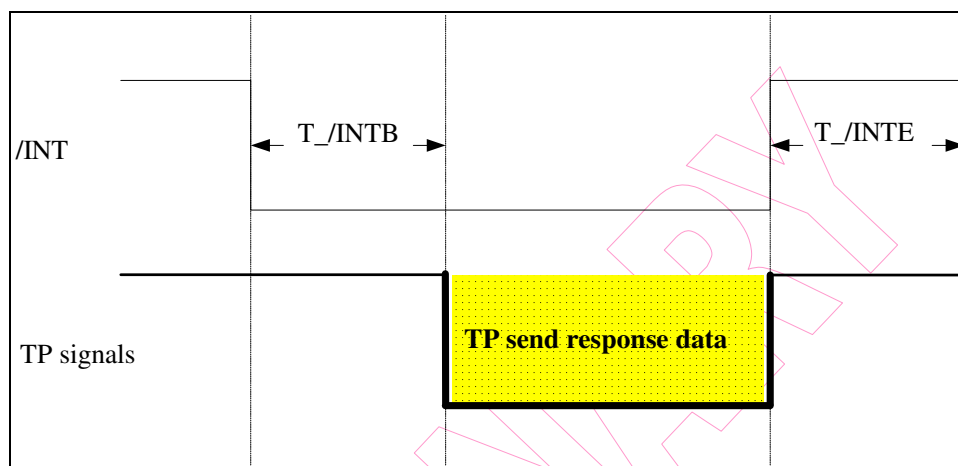

/INT Signal	Condition		Description
T_/INTB	100 μs (min)	130 μs (Typ.)	Minimum preparation time from pulling the /INT low and begin sending response data
T_/INTE	100 μs (max)	50 μs (Typ.)	Maximum preparation time to end sending response data and pulling the /INT high

Fig. 8-1 /INT Pin Timing Diagram

8.3 I/O-Output Pin

Fig. 8-2 shows the system block diagram including I/O-Output. The eKT8100A detects the object on the touch pad sensor and sends the information in each mode including scroll bar S1 position change information and button state to host.

In I/O-Output interface, the IO_SW1 ~ IO_SW6 signals connect to host control signals and the IO_SW7_Scroll+ , IO_SW7_Scroll- should be pulled high with 200Ω resistors on the end of the host. All I/O-Output are normal high and active **low**.

Since the eKT8100A usually runs SPI or UART, if host wants to only use I/O-Output (without protocol communication), the circuit design on SDI_RX, SDO_TX, and SCK will be fixed. The SDI_RX and SDO_TX are both connected to VDD and the SCK connects to GND.

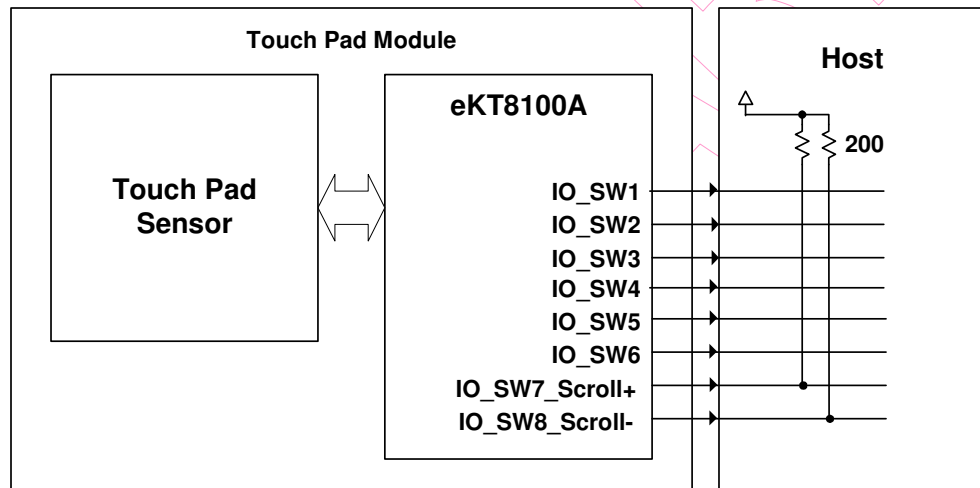

Fig. 8-2 System Block Diagram including I/O-Output Interface

The IO-Output Interface is used for a quickly communication of host processor and peripherals. A couple of 8-bit's multiple data are transmitted at the same time. Fig. 8-3a and Fig. 8-3b shows the finger status, switch I/O and scroll I/O operating timing. Fig. 8-4 shows the timing of multi-switch I/O operation with enabling multi-finger function.

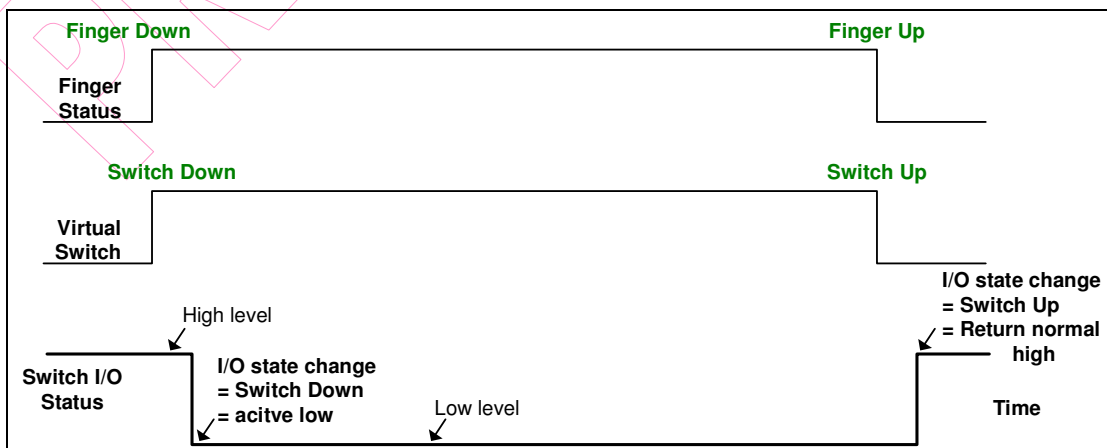

Fig. 8-3a the Timing of Touch Pad Switch I/O Operating

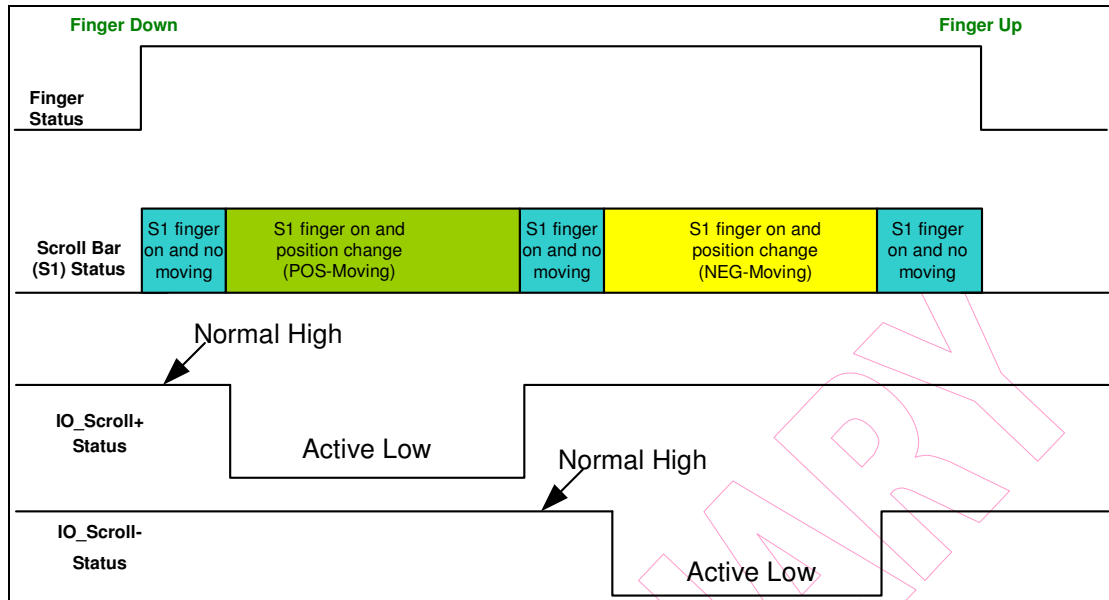

Fig. 8-3b the Timing of Touch Pad Scroll Bar (S1) I/O Operating

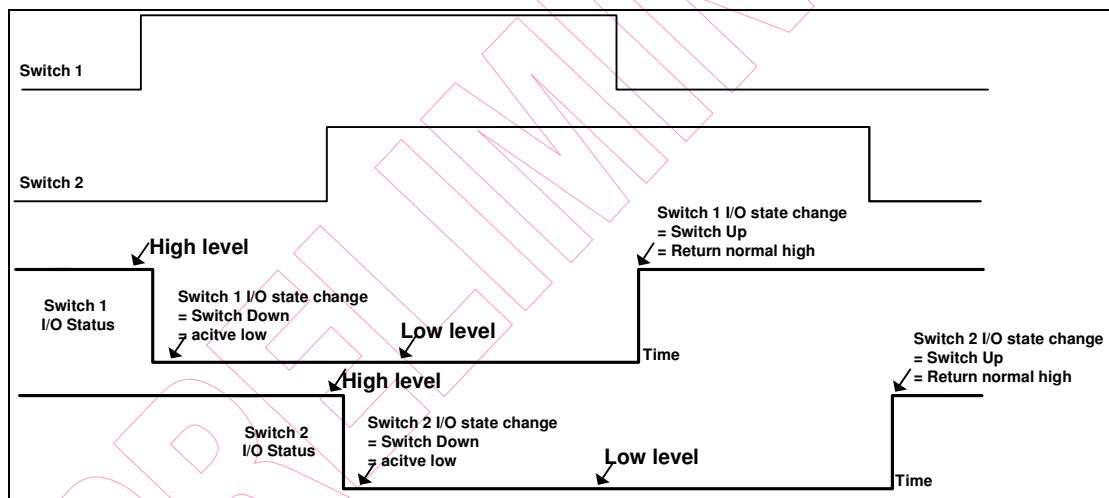

Fig. 8-4 Timing Diagram of a Multi-Switch I/O Operation (enable multi-finger function)

9 Electrical Characteristic

9.1 Absolute Maximum Ratings

Item	Min.	Max.	Unit
Temperature under bias	-40	85	°C
Storage temperature	- 65	150	°C
Operating humidity (test 8h)	5	95	%
Voltage from VDD to VSS	- 0.5	7.0	V
Voltage from any pin to VSS	- 0.5	7.0	V
Chip level ESD (HBM test)	2	-	KV

9.2 DC Electrical Characteristic

Symbol	Parameter	Condition	Min.	Typ.	Max.	Unit
DVDD	Power supply voltage request	General purpose	2.6	-	5.5	V
I_Normal1	Normal operating current (Mode 1)	2.8V power supply 6MHz RC oscillator	-	0.5	1.5	mA
I_Idle1	Idle operating current (Mode 1)	2.8V power supply	-	110	200	μA
I_Sleep1	Sleep operating current (Mode 1)	2.8V power supply	-	2	20	μA
I_Normal2	Normal operating current (Mode 2)	2.8V power supply 6MHz RC oscillator	-	0.72	1.5	mA
I_Idle2	Idle operating current (Mode 2)	2.8V power supply	-	170	250	μA
I_Sleep2	Sleep operating current (Mode 2)	2.8V power supply	-	2	20	μA
I_Normal3	Normal operating current (Mode 3)	2.8V power supply 6MHz RC oscillator	-	0.73	1.5	mA
I_Idle3	Idle operating current (Mode 3)	2.8V power supply	-	180	250	μA
I_Sleep3	Sleep operating current (Mode 3)	2.8V power supply	-	2	20	μA
MCU Operation						
V_OH	Output high level	5V power supply I_DRIVER = 7mA	2.4	-	-	V
V_OL	Output low level	5V power supply I_SINK = 7mA	-	-	0.4	V
V_IH	Input high voltage level	5V power supply	2.0	-	-	V
V_IL	Input low voltage level	5V power supply	-	-	0.8	V
I_IL	Input leakage current for input pins	VIN = VDD, VSS	-	-	1	μA

9.3 AC Electrical Characteristic

Symbol	Parameter	Condition	Min.	Typ.	Max.	Unit
F_OSC1	External R internal C oscillator	2.8V power supply	-	6	-	MHz
F_OSC3	Internal RC oscillator	2.8V power supply	-	512	-	kHz

10 Application Circuit

10.1 Mode1 (Button mode)

10.1.1 LQFP 64

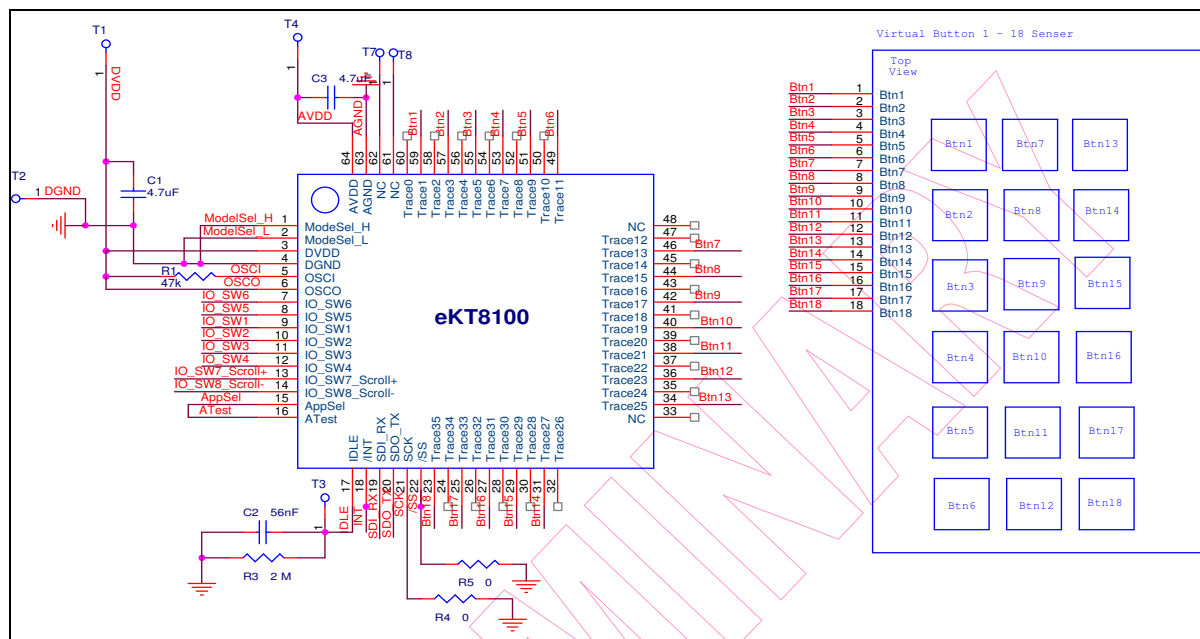

■ BOM Table

Component	Component P/N	Pin Location	Package	Qty.
MCU	eKT8100A	U1	LQFP64	1
Resistor	47kΩ	R1	SMD	1
Resistor	2MΩ	R2	SMD	1
Resistor	0Ω	R4, R5	SMD	2
Capacitor	4.7µF	C1, C3	SMD	2
Capacitor	56nF	C2	SMD	1

10.1.2 QFN 40

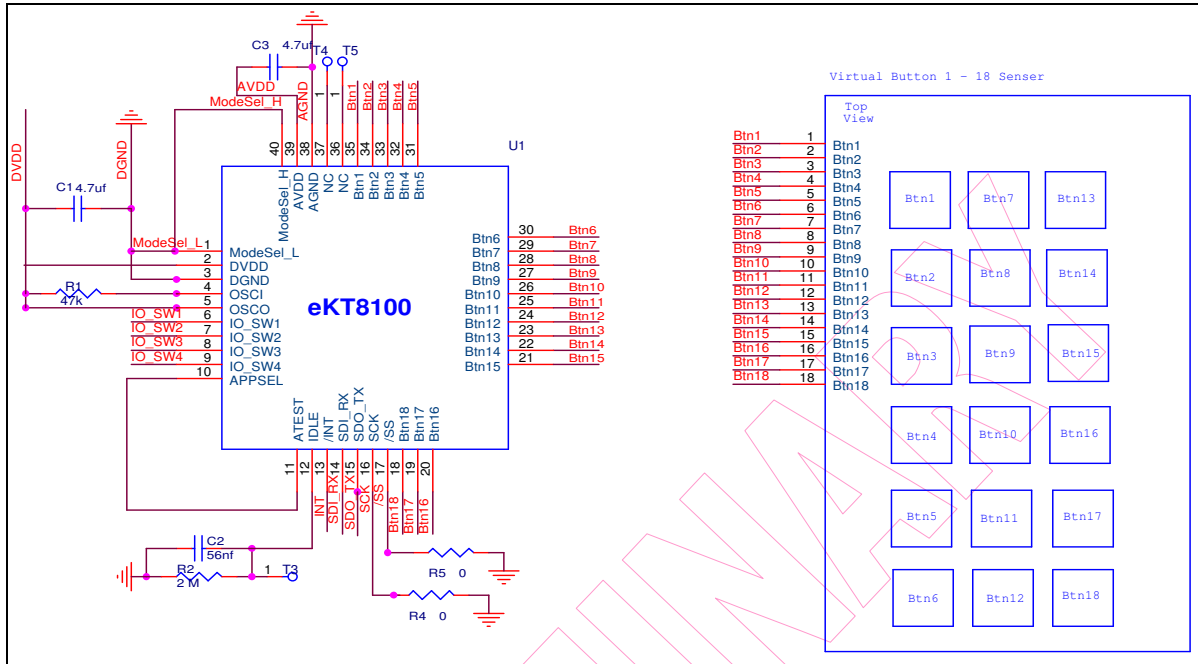

■ BOM Table

Component	Component P/N	Pin Location	Package	Qty.
MCU	eKT8100A	U1	QFN40	1
Resistor	47kΩ	R1	SMD	1
Resistor	2MΩ	R2	SMD	1
Resistor	0Ω	R4, R5	SMD	2
Capacitor	4.7μF	C1, C3	SMD	2
Capacitor	56nF	C2	SMD	1

10.2 Mode 2 (Single Scroll Mode)

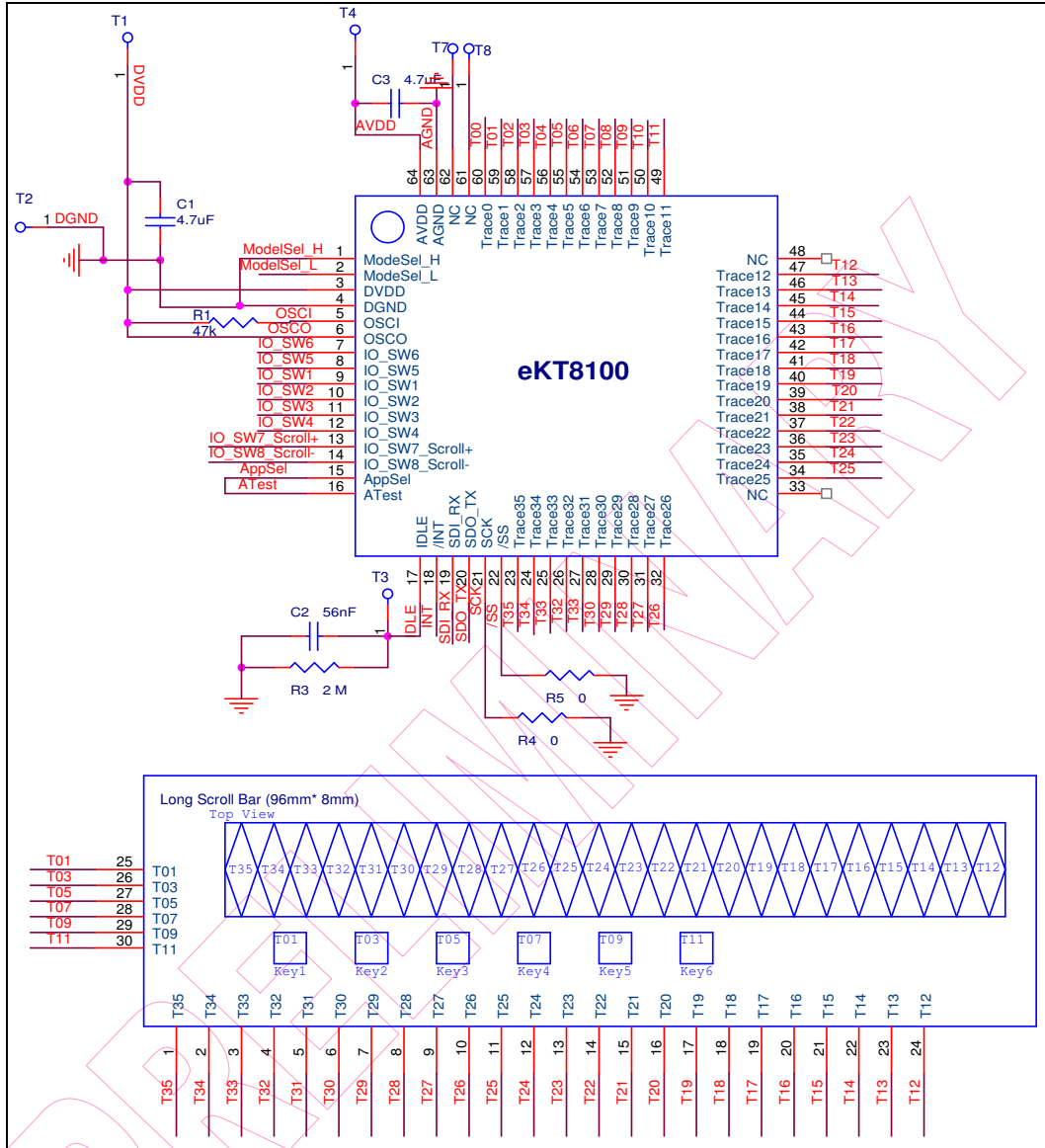

■ BOM Table

Component	Component P/N	Pin Location	Package	Qty.
MCU	eKT8100A	U1	QFN40	1
Resistor	47kΩ	R1	SMD	1
Resistor	2MΩ	R2	SMD	1
Resistor	0Ω	R4, R5	SMD	2
Capacitor	4.7µF	C1, C3	SMD	2
Capacitor	56nF	C2	SMD	1

10.3 Mode 3 (Double Scroll Mode)

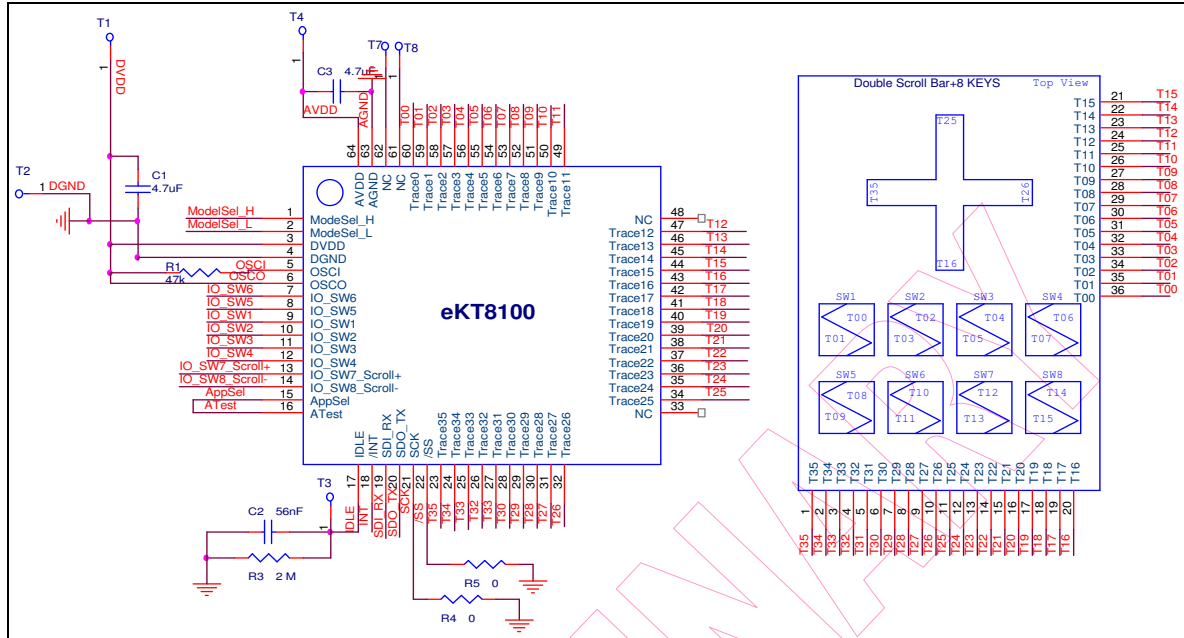

■ BOM Table

Component	Component P/N	Pin Location	Package	Qty.
MCU	eKT8100A	U1	QFN40	1
Resistor	47kΩ	R1	SMD	1
Resistor	2MΩ	R2	SMD	1
Resistor	0Ω	R4, R5	SMD	2
Capacitor	4.7μF	C1, C3	SMD	2
Capacitor	56nF	C2	SMD	1

11 Protocol Description

After power on, the touch pad (TP) will send “Packet Hello” to let the host know that TP is ready for operation. When TP detects button status, it then sends the new information to host.

In UART mode, Host should send “Packet Synchronous” to TP after receiving the “Packet Hello” from TP for synchronization interface. If host receives an unknown Packet ID, host can receive the correct packet after sending the “Packet Synchronous”.

The TP always send Packet ID #6(Mode1) or Packet ID #8 (Mode 2/Mode 3) unless specifically asked by the host to send another type. In the case of sending another Packet ID, the TP will only send once for each request by the host and then revert to the type of Packet ID #6 or Packet ID #8. The touch pad will send Packet ID #6 packet or Packet ID #8 whenever it detects a change of sensing status.

Host can change Touch pad’s power status or sensitivity by sending Packet ID #4 with the correct register number. It can also read information immediately by sending Packet ID #3 with the correct register number; then TP will send Packet ID #2 in response to this command.

No matter which interfaces are used, the definition of the report packet is the same.

11.1 Command Description

11.1.1 Packet Synchronous (Host to Device, UART Mode Only)

31	30~24	23~16	15~8	7~1	0
0	0000000	00000000	00000000	0000000	0

Comment: This packet is used for interface synchronization in UART mode. After the host turns on the touch pad power, and received undefined packet ID, host should send this packet to do interface synchronization.

11.1.2 Packet Hello (Device to Host; Mode 1 Only)

31	30~24	23~16	15~8	7~1	0
0	1010101	01010101	01010101	0101010	1

Comment: After the touch pad is powered on, TP will send “Packet Hello” to host

11.1.3 Packet Hello (Device to Host; Mode 2 and Mode 3 Only)

39	38~32	23~16	23~16	15~8	7~1	0
0	1010101	01010101	01010101	01010101	0101010	1

Comment: After the touch pad is powered on, TP will send “Packet Hello” to host

11.1.4 Packet ID #6 (Device to Host; Mode 1)

31	Type	PID	Reserve	Button (Btn1 ~ Btn18)	Reserve	0
31	30~28	27~24	23~20	19~2	1	0
0	101	0110	0000	1 : ON 0 : OFF	0	1

Comment: A. Enable multi-finger function: The Touch pad will send this packet if the button status is changed. The timing diagram is shown in Fig. 10-1

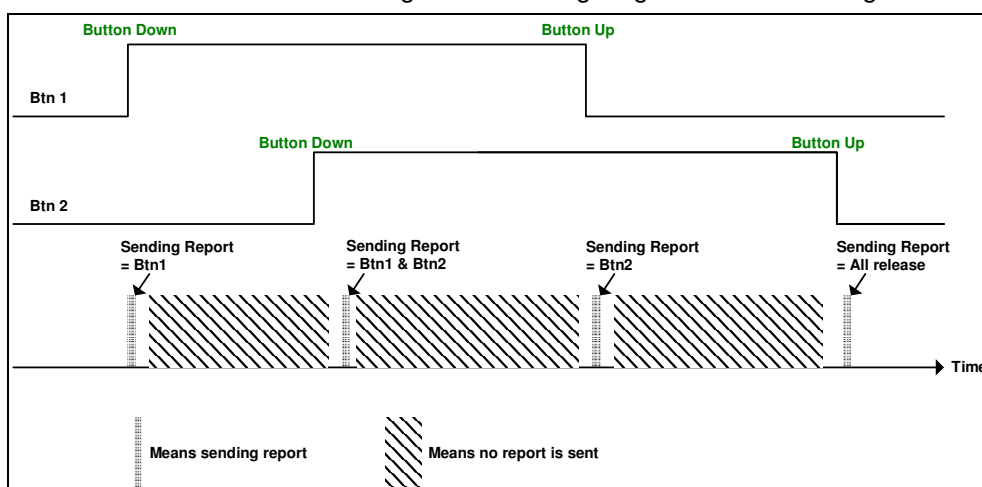

Fig. 11-1 Enable Multi-Finger Timing Diagram

B. Disable multi-finger function: eKT8100A only output single key information though multi keys are pressed. eKT8100A kernel will calculate the weight of every pressed key and output the highest sensing key. The timing diagram is shown in Fig.10-2.

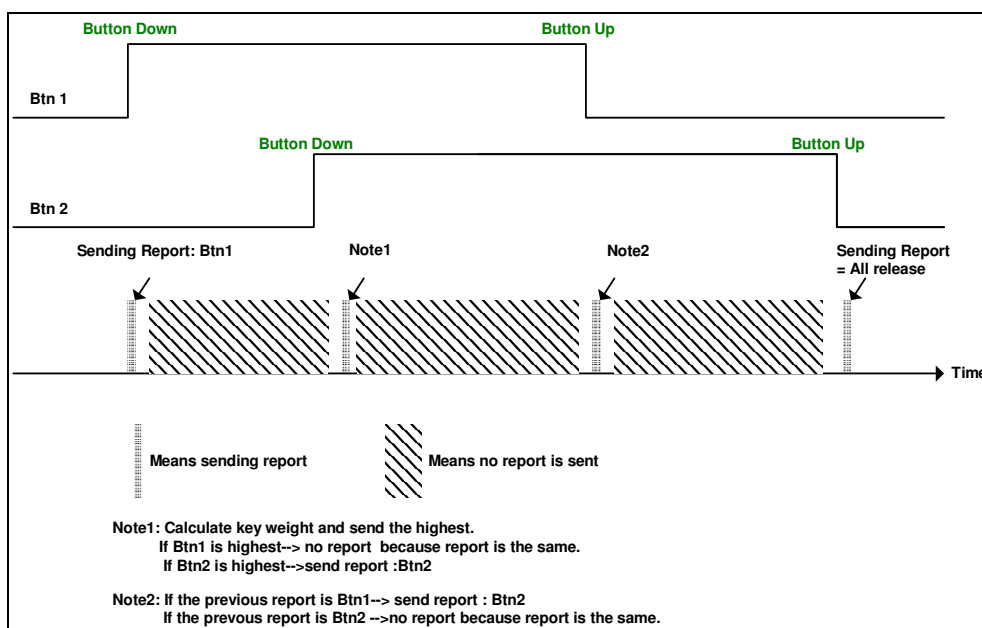

Fig. 11-2 Disable Multi-Finger Timing Diagram



EX: If Btn1 is pressed, the packet is 0B01010110 00001000 00000000 00000001.

EX: If Btn18 is pressed, the packet is 0B01010110 00000000 00000000 00000101.

EX: If Btn2 and Btn3 are pressed and enable multi-finger function, the packet is
0B01010110 00000110 00000000 00000001.

EX: If Btn2 and Btn3 and Btn5 are pressed and enable multi-finger function, the packet
is 0B01010110 00000110 10000000 00000001.

EX: If the Button status is released, the bit will be 0.

11.1.5 Packet ID #8 (Device to Host; Mode 2 and Mode 3)

	Type	PID	S1 Position	S2 Position	Button	S1 Finger	S2 Finger	Reserve	
39	38~36	35~32	31~24	23~16	15~8	7~6	5~4	3~1	0
0	101	1000	Absolute Position	Absolute Position	0 : Off 1 : On	Finger Numbers	Finger Numbers	000	1

Comment: The Touch pad will send this packet if the state of S1 absolute position, S2 absolute position, or button status is changed. User can select whether enable Multi-finger function (**it is only used for virtual button**) and then report form is the same as 10.1.4. The timing is shown in Fig. 10-3.

EX: If Btn1 is pressed and S1-position is 96 (one finger) and S2 with no finger, the packet is 0B01011000 01100000 11111111 10000000 01000001.

EX: If Btn1 is pressed and S2-position is 96 (one finger) and S1 with no finger, the packet is 0B01011000 11111111 01100000 10000000 00010001.

EX: If no button is pressed and S1-position is 96 (one finger) and S2-position is 96 (1 finger), the packet is 0B01011000 01100000 01100000 00000000 01010001.

EX: If no button is pressed and S1-position is 96 (two fingers) and S2 with no finger, the packet is 0B01011000 01100000 11111111 00000000 10000001.

EX: If no button is pressed and S2-position is 96 (two fingers) and S1 with no finger, the packet is 0B01011000 11111111 01100000 00000000 00100001.

EX: If there is no finger on S1 or S2, and the position is 0xFF.

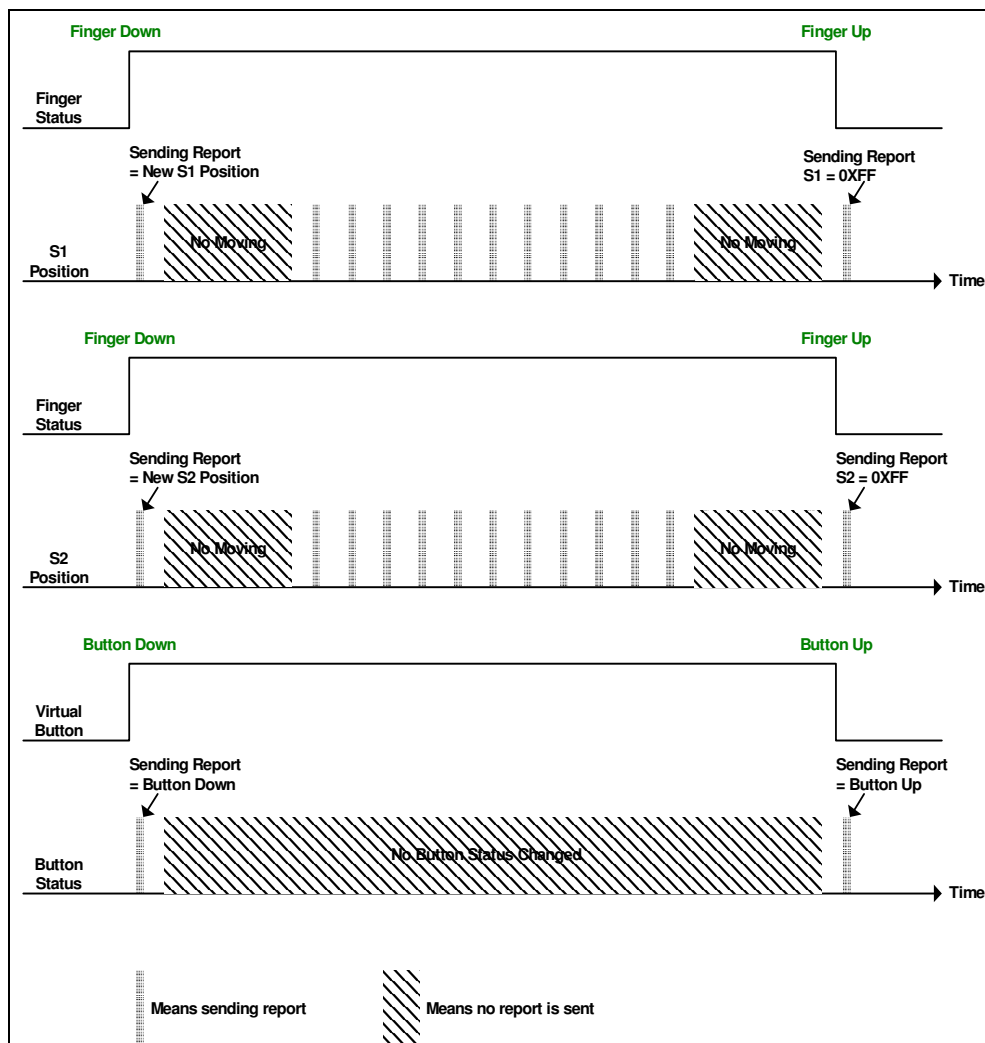

Fig. 11-3 Timing of Touch Pad Operation

11.1.6 Packet ID #2 (Device to Host)

	Type	PID	Register No.	Read Register Response Data	Reserve	
31	30~28	27~24	23~20	19~4	3~1	0
0	101	0010	-	-	000	1

Comment: The Touch pad will send this packet in response to Packet ID #3. The response data is determined by the register number in Packet ID #3. Refer to register number description.

EX: Host send command to TP's button status, if Btn1 is pressed, the packet is
0B01010010 00011000 00000000 00000001.

EX: Host send command to TP's button status, if Btn18 is pressed, the packet is
0B01010010 00010000 00000000 00000101.



EX: Host send command to TP's button status, if Btn2 and Btn3 are pressed, the packet is 0B01010010 00010110 00000000 00000001.

EX: Host send command to TP's button status, if no button is pressed, the packet is 0B01010010 00010000 00000000 00000001.

11.1.7 Packet ID #3 (Host to Device)

	Type	PID	Register No.	Reserve	Reserve	
31	30~28	27~24	23~20	19~4	3~1	0
0	101	0011			000	1

Comment: This is a read command packet. The Host can read the information in different register number. Refer to register number description.

11.1.8 Packet ID #4 (Host to Device)

	Type	PID	Register No.	Register Data	Reserve	
31	30~28	27~24	23~20	19~4	3~1	0
0	101	0100			000	1

Comment: This is a write command packet. Host can change the Sensitivity or the Power State via sending this packet. Refer to register number description.

EX: If host wants to change sensitivity to 5, the packet is 0B01010100 01000101 00000000 00000001.

EX: If host wants to set the Power Status as 1, the packet is 0B01010100 01011000 00000000 00000001.

11.2 Register Description

The register numbers in Packet ID #2, Packet ID #3 and Packet ID #4 are defined as follows:

11.2.1 Register Number = 0, Read F/W Version (Read Only)

	Type	PID	Register No.	Reserve	Reserve	
31	30~28	27~24	23~20	19~4	3~1	0
0	101	0011	0000	00000000 00000000	000	1

Comment: If the host wants to read the firmware version of the touch pad, it should send Packet ID #3 with register number 0000.



	Type	PID	Register No.	Read Register Response Data	Reserve	
31	30~28	27~24	23~20	19~4	3~1	0
0	101	0010	0000	00000001 00000000	000	1

Comment: The touch pad will then return the firmware version by sending Packet ID #2 to host.

Bit 19 ~ Bit 12: Major Version

Bit 11 ~ Bit 4: Minor Version

11.2.2 Register Number = 1, Read Button Status (Read Only)

	Type	PID	Register No.	Reserve	Reserve	
31	30~28	27~24	23~20	19~4	3~1	0
0	101	0011	0001	00000000 00000000	000	1

Comment: If the host wants to read the button status of the touch pad, it should send Packet ID #3 with register number 0001.

	Type	PID	Register No.	Read Register Response Data	Reserve	
31	30~28	27~24	23~20	19~2	1	0
0	101	0010	0001	00000000 00000000 00	0	1

Comment: The touch pad will then return the button status by sending Packet ID #2 to host.

Bit 19 : Btn1 ; 1 = Button pressed, 0 = Button released

Bit 18 : Btn2 ; 1 = Button pressed, 0 = Button released

Bit 17 : Btn3 ; 1 = Button pressed, 0 = Button released

Bit 16 : Btn4 ; 1 = Button pressed, 0 = Button released

Bit 15 : Btn5 ; 1 = Button pressed, 0 = Button released

Bit 14 : Btn6 ; 1 = Button pressed, 0 = Button released

Bit 13 : Btn7 ; 1 = Button pressed, 0 = Button released

Bit 12 : Btn8 ; 1 = Button pressed, 0 = Button released

Bit 11 : Btn9 ; 1 = Button pressed, 0 = Button released

Bit 10 : Btn10 ; 1 = Button pressed, 0 = Button released

Bit 09 : Btn11 ; 1 = Button pressed, 0 = Button released

Bit 08 : Btn12 ; 1 = Button pressed, 0 = Button released

Bit 07 : Btn13 ; 1 = Button pressed, 0 = Button released

Bit 06 : Btn14 ; 1 = Button pressed, 0 = Button released

Bit 05 : Btn15 ; 1 = Button pressed, 0 = Button released

Bit 04 : Btn16 ; 1 = Button pressed, 0 = Button released

Bit 03 : Btn17 ; 1 = Button pressed, 0 = Button released

Bit 02 : Btn18 ; 1 = Button pressed, 0 = Button released

11.2.3 Register Number = 2, Read S1 Position (Read Only)

	Type	PID	Register No.	Reserve	Reserve	
31	30~28	27~24	23~20	19~4	3~1	0
0	101	0011	0010	00000000 00000000	000	1

Comment: If host wants to read the S1 position of the touch pad, it should send Packet ID #3 with register number 0010.

	Type	PID	Register No.	Read Register Response Data	Reserve	
31	30~28	27~24	23~20	19~12	11~1	0
0	101	0010	0010	00000000	00000000 000	1

Comment: The touch pad will then return the S1 position by sending Packet ID #2 to host.

Mode 1 (Full button mode): All return 255.

Mode 2 (Single scroll bar): Bit 19 ~ Bit 12: S1 position; the position range is 0 ~ 175 and 255 means no finger is on this axis. The traces of the scroll bar are made up of T35~T12. If user doesn't need so many traces, scroll bar resolution = ((number of trace-2) × 8) + 4.

EX: if only 8 traces are used, the resolution is ((8-2) × 8) + 4 = 52 dots.

Mode 3 (Double scroll bar): Bit 19 ~ Bit 12: S1 position; the position range is 0 ~ 63 and 255 means no finger is on this axis. The traces of S1 are made up of T35~T26 and S2 are made up of T25~T16. The resolution algorithm of the scroll bar is the same as that of the Single scroll bar above if user does not need so many traces.

11.2.4 Register Number = 3, Read S2 Position (Read Only)

	Type	PID	Register No.	Reserve	Reserve	
31	30~28	27~24	23~20	19~4	3~1	0
0	101	0011	0011	00000000 00000000	000	1

Comment: If the host wants to read the S2 position of the touch pad, it should send Packet ID #3 with register number 0011.

	Type	PID	Register No.	Read Register Response Data	Reserve	
31	30~28	27~24	23~20	19~12	11~1	0
0	101	0010	0011	00000000	00000000 000	1

Comment: The touch pad will then return the S2 position by sending Packet ID #2 to host.

Mode 1 (Full button mode): All return 255.

Mode 2 (Single scroll bar): All return 255.

Mode 3 (Double scroll bar): Bit 19 ~ Bit 12: S2 position; the position range is 0 ~ 63 and 255 means no finger is on this axis. The resolution algorithm of the scroll bar is the same as that of the Single scroll bar above if user does not need so many traces.

11.2.5 Register Number = 4, TP Sensitivity Setting(R/W)

	Type	PID	Register No.	Reserve	Reserve	
31	30~28	27~24	23~20	19~4	3~1	0
0	101	0011	0100	00000000 00000000	000	1

Comment: If host wants to read the sensitivity of touch pad, it should send Packet ID #3 with register number 0100.

	Type	PID	Register No.	Read Register Response Data	Reserve	
31	30~28	27~24	23~20	19~4	3~1	0
0	101	0010	0100	00000000 00000000	000	1

Comment: The touch pad will then return the sensitivity by sending Packet ID #2 to host.

Bit 19 ~ Bit 16: Sensitivity, the sensitivity range is 0 ~ 6.

	Type	PID	Register No.	Write Register Data	Reserve	
31	30~28	27~24	23~20	19~4	3~1	0
0	101	0100	0100	00000000 00000000	000	1

Comment : If the host wants to write the sensitivity of the touch pad, it should send Packet ID #4 with register number 0100. Then the touch pad will keep the value.

Bit 19 ~ Bit 16: Sensitivity, the sensitivity range is 0 ~ 6. The default value is 2.

11.2.6 Register Number = 5, TP Power State Setting(R/W)

	Type	PID	Register No.	Reserve	Reserve	
31	30~28	27~24	23~20	19~4	3~1	0
0	101	0011	0101	00000000 00000000	000	1

Comment: If host wants to read the power state of the touch pad, it should send Packet ID #3 with register number 0101.

	Type	PID	Register No.	Read Register Response Data	Reserve	
31	30~28	27~24	23~20	19~4	3~1	0
0	101	0010	0101	00000000 00000000	000	1

Comment: The touch pad will then return the power state by sending Packet ID #2 to host.

Bit 19: Power State : 1 = Normal Operation, 0 = Deep Sleep

	Type	PID	Register No.	Write Register Data	Reserve	
31	30~28	27~24	23~20	19~4	3~1	0
0	101	0100	0101	00000000 00000000	000	1

Comment : If host wants to write the power state of the touch pad, it should send Packet ID #4 with register number 0101. Then the touch pad will keep the value.

Bit 19 : Power State : 1 = Normal Operation, 0 = Deep Sleep

11.2.7 Register Number = 6, Multi-Finger Function Setting(R/W)

	Type	PID	Register No.	Reserve	Reserve	
31	30~28	27~24	23~20	19~4	3~1	0
0	101	0011	0110	00000000 00000000	000	1

Comment: If host wants to read the multi-finger state of the touch pad, it should send Packet ID #3 with register number 0110.

NOTE

This function is only for the button including the button of Modes 1, 2, 3. In other words, it excludes the scroll bar.

	Type	PID	Register No.	Read Register Response Data	Reserve	
31	30~28	27~24	23~20	19~4	3~1	0
0	101	0010	0110	00000000 00000000	000	1

Comment: The touch pad will then return the multi-finger state by sending Packet ID #2 to host.

	Type	PID	Register No.	Write Register Data	Reserve	
31	30~28	27~24	23~20	19~4	3~1	0
0	101	0100	0110	00000000 00000000	000	1

Comment : If host wants to enable multi-finger function of the touch pad, it should send Packet ID #4 with register number 0110. Then the touch pad will retain the value.

Bit 19: Multi-finger State : 1 = Enable Multi-Finger function
0 = Disable Multi-Finger function (default)

11.2.8 Register Number = 13, TP Cold –Reset (Write Only)

	Type	PID	Register No.	Reserve	Reserve	
31	30~28	27~24	23~20	19~4	3~1	0
0	101	0100	1101	00000000 00000000	000	1

Comment: If host wants to cold-reset the touch pad, it should send Packet ID #4 with register number 1101. Then the touch pad will stop scanning, load the default setting, and send Hello packet.

Bit 19: Cold-Reset State, 0 = OFF, 1 = ON

11.2.9 Register Number = 14, TP Report Rate Setting(R/W)

	Type	PID	Register No.	Reserve	Reserve	
31	30~28	27~24	23~20	19~4	3~1	0
0	101	0011	1110	00000000 00000000	000	1

Comment: If host wants to read the report rate of the touch pad, it should send Packet ID #3 with register number 1110.



	Type	PID	Register No.	Read Register Response Data	Reserve	
31	30~28	27~24	23~20	19~4	3~1	0
0	101	0010	1110	00000000 00000000	000	1

Comment: The touch pad will then return the report rate by sending Packet ID #2 to host.

	Type	PID	Register No.	Write Register Data	Reserve	
31	30~28	27~24	23~20	19~4	3~1	0
0	101	0100	1110	00000000 00000000	000	1

Comment : If host wants to write the report rate of the touch pad, it should send Packet ID #4 with register number 11110 Then the touch pad will keep the value.

Bit 19: Report rate; 1 = Normal report rate (default), 0 = Faster report rate.

In SPI mode, normal report rate is 20 ms and faster report rate is 12 ms.

In UART mode, normal report rate is 25 ms and faster report rate is 17ms.

11.2.10 Register Number = 15, Read Firmware ID (Read Only)

	Type	PID	Register No.	Reserve	Reserve	
31	30~28	27~24	23~20	19~4	3~1	0
0	101	0011	1111	00000000 00000000	000	1

Comment : If host wants to read the firmware ID of the touch pad, it should send Packet ID #3 with register number 1111.

	Type	PID	Register No.	Read Register Response Data	Reserve	
31	30~28	27~24	23~20	19~4	3~1	0
0	101	0010	1111	10000001 00000000	000	1

Comment : The touch pad will then return the firmware ID by sending Packet ID #2 to host.

Bit 19 ~ Bit 12: firmware ID high byte

Bit 11 ~ Bit 4: firmware ID low byte

For this controller, the firmware ID is 8100:

Firmware ID high byte = 0x81

Firmware ID low byte = 0x00

12 Package Specification

12.1 LQFP64

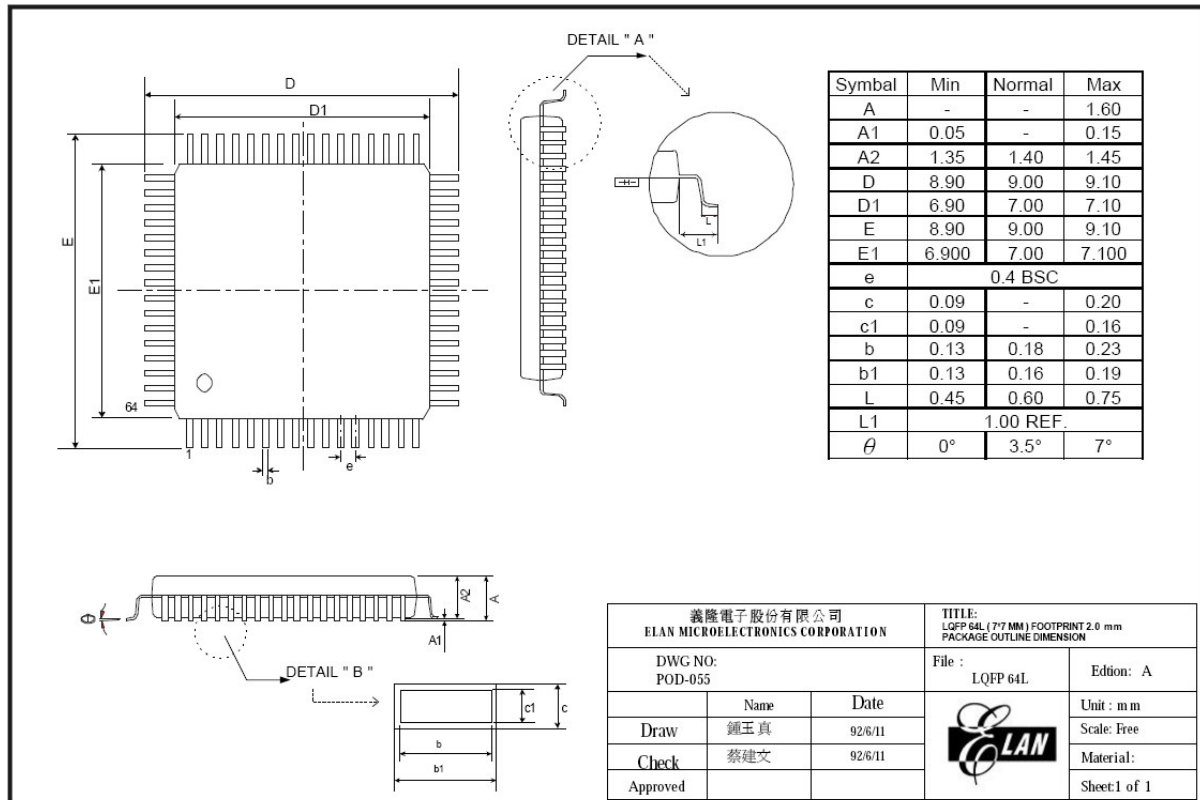

12.2 QFN40

