



# EMIF06-AUD01F2

## 6-line EMI filter and ESD protection for audio interface

### Features

- 4-line EMI filter and ESD protection for internal and external (headset) microphone
- 2-line EMI filter and ESD protection for headset speaker

### Benefits

- EMI (I/O) low-pass filter
- High efficiency EMI filter
- Very low PCB space consumption: 4.6 mm<sup>2</sup>
- Very thin package: 0.65 mm
- High efficiency in ESD suppression
- High reliability offered by monolithic integration
- High reduction of parasitic elements through integration and wafer level packaging

### Complies with following standards

- IEC 61000-4-2 level 4 external pins
  - 15 kV (air discharge)
  - 8 kV (contact discharge)
- IEC 61000-4-2 level 1 internal pins
  - 2 kV (air discharge)
  - 2 kV (contact discharge)

### Applications

ESD protection and EMI/RFI filtering for the audio bottom connector interface, where EMI filtering in ESD sensitive equipment is required:

- Mobile phones and communication systems
- Wireless modules

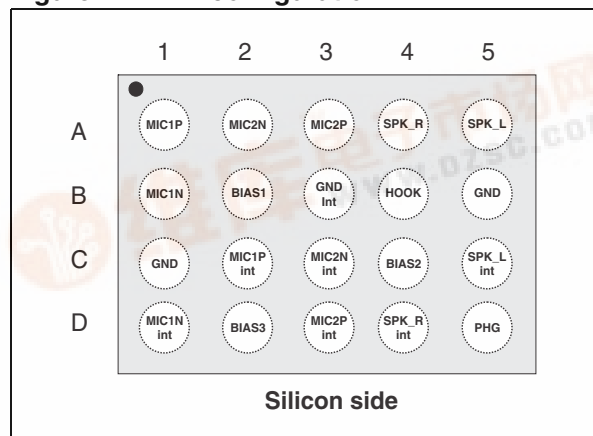


### Description

The EMIF06-AUD01F2 is a highly integrated device designed to suppress EMI/RFI noise in all systems subjected to electromagnetic interference. The flip chip packaging means the package size is equal to the die size.

This filter includes ESD protection circuitry, which prevents damage to the application when it is subjected to ESD surges up to 15 kV.

**Figure 1. Pin configuration**



# 1 Characteristics

Figure 2. Circuit schematic

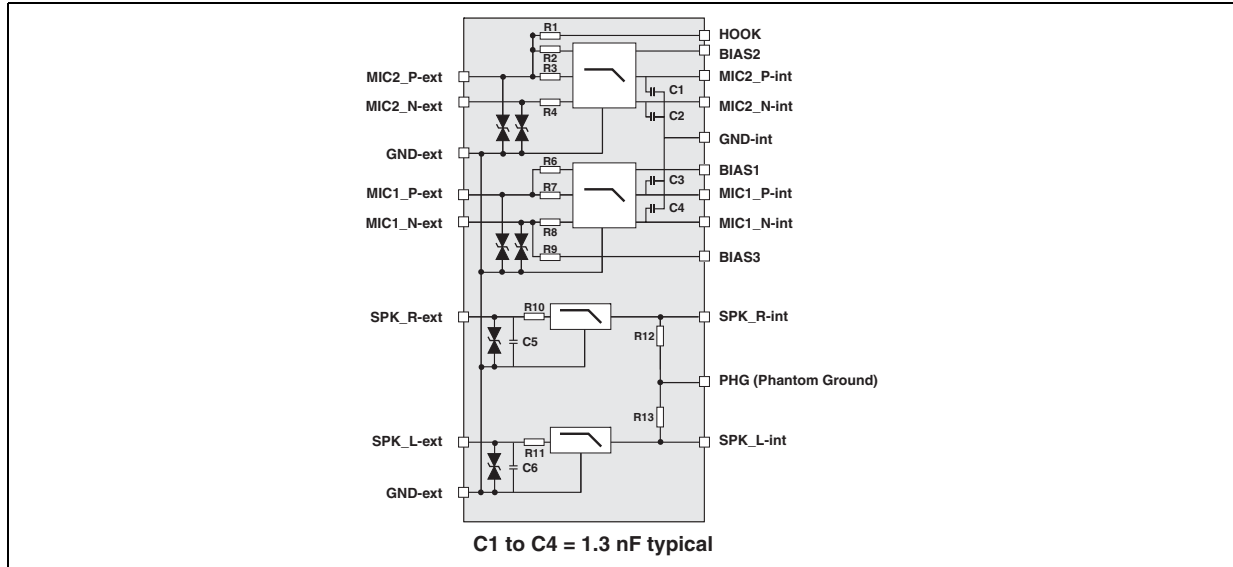


Table 1. Absolute ratings (limiting values)

Symbol	Parameter	Test conditions	Min	Max	Unit
$V_{pp}$	IEC61000-4-2 air discharge on external lines			15	kV
	IEC61000-4-2 contact discharge on external lines			15	
	IEC61000-4-2 air discharge on internal lines			2	
	IEC61000-4-2 contact discharge on internal lines			2	
$P_{SPK}$	Continuous power dissipation per channel SPK_L, SPK_R	$T_{amb} = 85\text{ }^{\circ}\text{C}$		180	mW
$I_{SPK}$	Continuous current per channel SPK_L, SPK_R	$T_{amb} = 85\text{ }^{\circ}\text{C}$		135	mA
$P_{total}$	Total continuous power dissipation	$T_{amb} = 85\text{ }^{\circ}\text{C}$		285	mW
$T_{op}$	Operating temperature range		-40	+85	$^{\circ}\text{C}$
$T_{stg}$	Storage temperature range		-40	+125	$^{\circ}\text{C}$
$T_j$	Junction temperature			+125	$^{\circ}\text{C}$

Table 2. Electrical characteristics - definitions ( $T_{amb} = 25\text{ }^{\circ}\text{C}$ )

Symbol	Parameters
$V_{BR}$	Breakdown voltage
$I_{RM}$	Leakage current @ $V_{RM}$
$V_{RM}$	Stand-off voltage
$V_{CL}$	Clamping voltage
$R_d$	Dynamic impedance
$I_{PP}$	Peak pulse current
$C_{line}$	Input capacitance per line

The graph plots current (I) on the vertical axis against voltage (V) on the horizontal axis. It shows the device's behavior under various conditions:  $V_{CL}$  (clamping voltage),  $V_{BR}$  (breakdown voltage),  $V_{RM}$  (stand-off voltage),  $I_{RM}$  (leakage current), and  $I_{PP}$  (peak pulse current).

**Table 3. Electrical characteristics - values ( $T_{amb} = -40\text{ °C}$  to  $+85\text{ °C}$  unless otherwise specified)**

Symbol	Parameter	Test conditions	Min	Typ	Max	Unit
$V_{BR}$	Diode reverse breakdown voltage	$I_R = 1\text{ mA}$ $T_{amb} = 25\text{ °C}$	14.0			V
$I_{RM}$	Leakage current through clamping diodes	$V_R = 3\text{ V DC}$ per line $T_{amb} = 25\text{ °C}$			0.5	$\mu\text{A}$
C1-C4 <sup>(1)</sup>	Capacitance on MIC lines	$V = 0\text{ V}$ , $F = 1\text{ MHz}$ ,		1.3		nF
C5-C6 <sup>(1)</sup>	Channel Capacitance SPK_L, SPK_R	$V_{OSC} = 30\text{ mV}$ $T_{amb} = 25\text{ °C}$		60		pF
R1 <sup>(2)</sup>	Hook Pull up resistance			47		k $\Omega$
R2 <sup>(2)</sup>	External Microphone Pull up resistance			2.2		k $\Omega$
R3,R4, R7, R8 <sup>(2)</sup>	Microphone Serial Resistance			100		$\Omega$
R6, R9 <sup>(2)</sup>	Internal Microphone Pull up and Pull down resistance			1		k $\Omega$
R10, R11 <sup>(3)</sup>	SPK Serial Resistance			10		$\Omega$
R12, R13 <sup>(2)</sup>	SPK PHG Resistance			15		k $\Omega$
MICx channel THD	Distortion	$V_{dc} = 0 - 2.4\text{ V}$ , <sup>(4)</sup> $F = 20\text{ Hz} - 20\text{ kHz}$ , $R_{gen} = 600\ \Omega$ $V_{out} = 1.5\text{ V}_{PP}$ $R_{load} = 200\text{ k}\Omega$ $T_{amb} = 25\text{ °C}$ Balanced (or differential mode)			-75	dB(A)

1. Capacitor tolerance  $\pm 30\%$
2. Resistor tolerances  $\pm 10\%$
3. Resistor tolerances  $\pm 20\%$
4. See [Figure 20](#) and [Figure 21](#)

## 1.1 RF filtering

The low signal level on the analog inputs and the pulsed transmitter in the phone are a combination that requires efficient RF-filtering. **RF-rectification must be avoided.** Therefore, the stop band attenuation is optimized for the frequency bands 800-2480 MHz.

**Table 4. Stop band performance 800 - 2480 MHz**

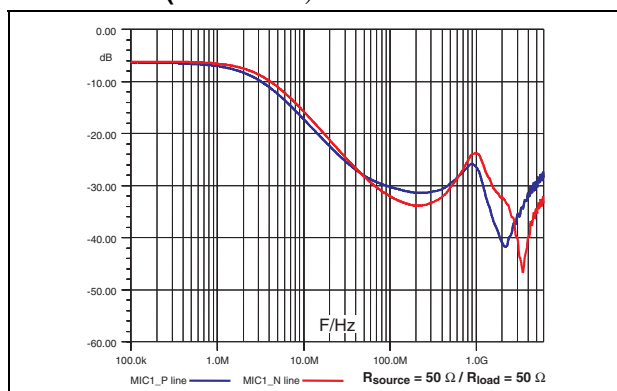
Channel	Test conditions	Attenuation			
		Min	Typ	Max	Unit
MIC1_x to MIC1_x-int	$R_{source} = 50 \Omega$ , $R_{load} = 1 \text{ k}\Omega$	25			dB
MIC2_x to MIC2_x-int	$R_{source} = 50 \Omega$ , $R_{load} = 1 \text{ k}\Omega$	25			dB
MIC1_P to BIAS1	$R_{source} = 50 \Omega$ , $R_{load} = 1 \text{ k}\Omega$	25			dB
MIC2_P to BIAS2	$R_{source} = 50 \Omega$ , $R_{load} = 1 \text{ k}\Omega$	25			dB
SPK_x to SPK_x-int	$R_{source} = 50 \Omega$ , $R_{load} = 1 \text{ k}\Omega$	25			dB

**Table 5. Stop band performance 10 - 800 MHz**

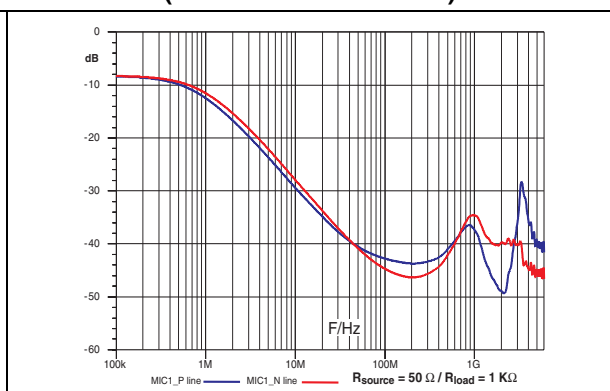
Channel	Test conditions	Attenuation			
		Min	Typ	Max	Unit
MIC1_x to MIC1_x-int	$R_{source} = 50 \Omega$ , $R_{load} = 1 \text{ k}\Omega$	20			dB
MIC2_x to MIC2_x-int	$R_{source} = 50 \Omega$ , $R_{load} = 1 \text{ k}\Omega$	20			dB
MIC1_P to BIAS1	$R_{source} = 50 \Omega$ , $R_{load} = 1 \text{ k}\Omega$	20			dB
MIC2_P to BIAS2	$R_{source} = 50 \Omega$ , $R_{load} = 1 \text{ k}\Omega$	20			dB

## 1.2 Attenuation characteristics

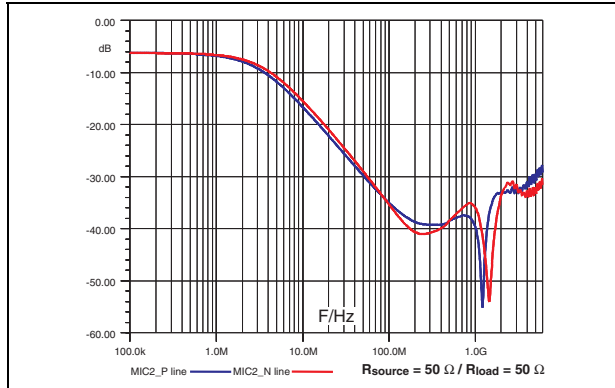
**Figure 3. S21 attenuation measurement MIC1\_P and MIC1\_N lines (50 Ω / 50 Ω)**



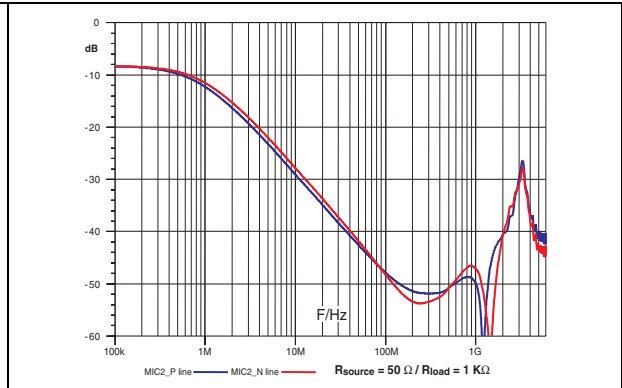
**Figure 4. S21 attenuation measurement MIC1\_P and MIC1\_N lines (50 Ω / 1 KΩ simulation)**



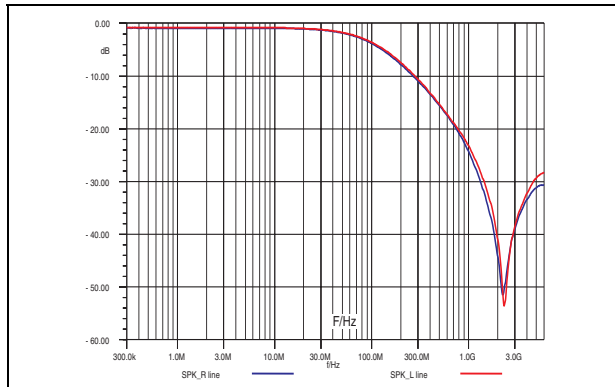
**Figure 5. S21 attenuation measurement MIC2\_P and MIC2\_N lines (50 Ω / 50 Ω)**



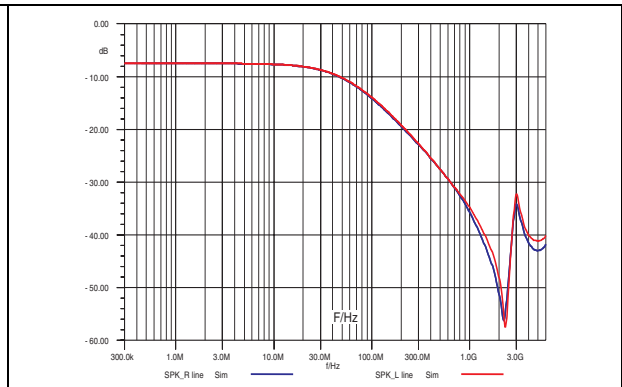
**Figure 6. S21 attenuation measurement MIC2\_P and MIC2\_N lines (50 Ω / 1 KΩ simulation)**



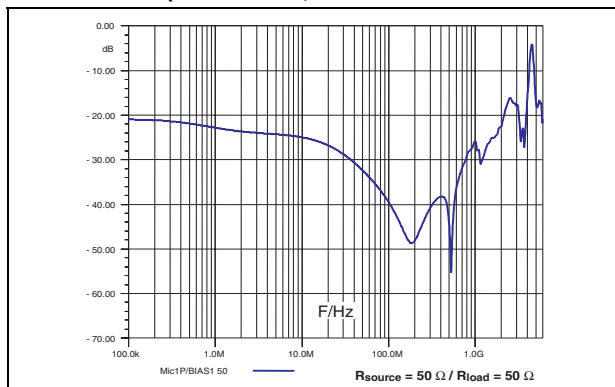
**Figure 7. S21 attenuation measurement SPK\_L and SPK\_R lines (50 Ω / 50 Ω)**



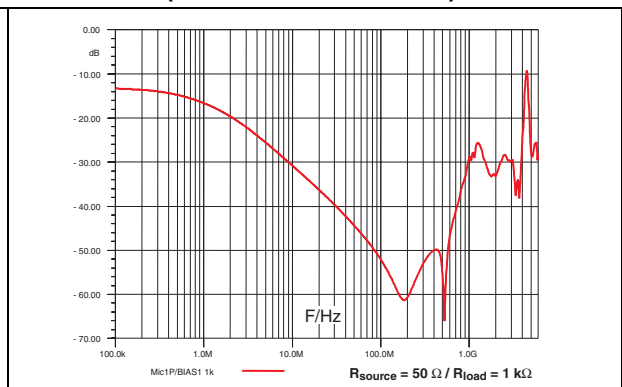
**Figure 8. S21 attenuation measurement SPK\_L and SPK\_R lines (50 Ω / 1 KΩ simulation)**



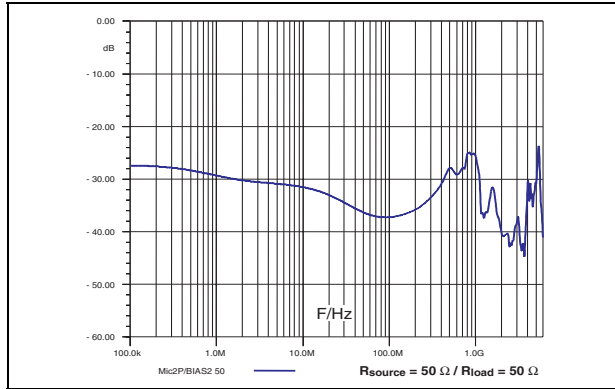
**Figure 9. S21 attenuation measurement MIC1\_P and BIAS1 lines (50 Ω / 50 Ω)**



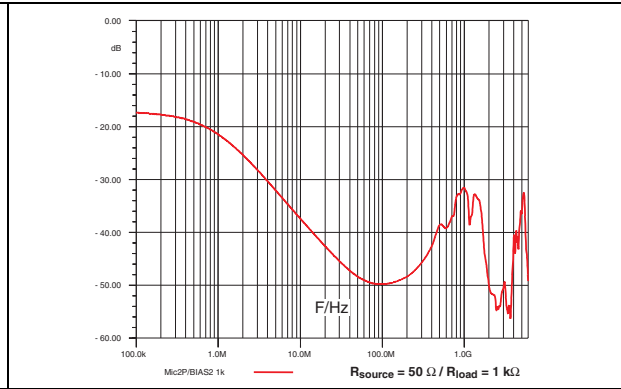
**Figure 10. S21 attenuation measurement MIC1\_P and BIAS1 lines (50 Ω / 1 KΩ simulation)**



**Figure 11. S21 attenuation measurement MIC2\_P and BIAS2 lines (50 Ω / 50 Ω)**

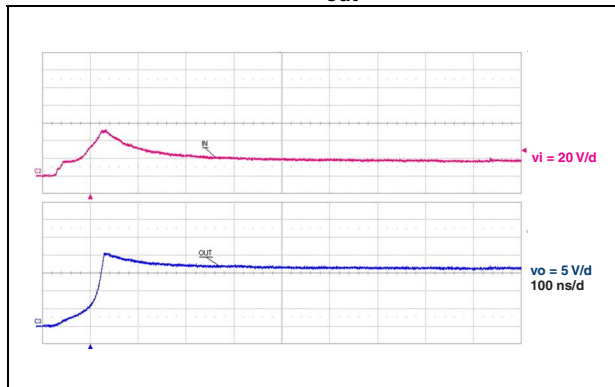


**Figure 12. S21 attenuation measurement MIC2\_P and BIAS2 lines (50 Ω / 1 KΩ simulation)**

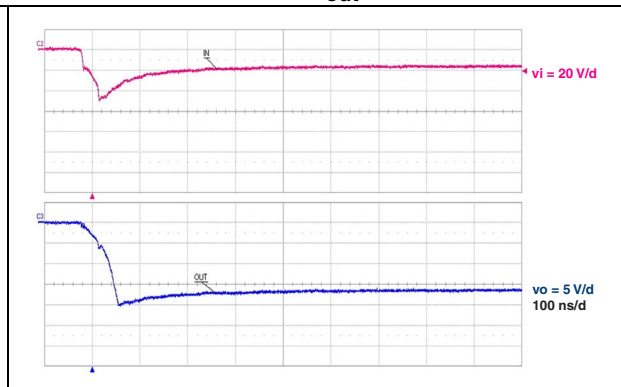


### 1.3 ESD characteristics

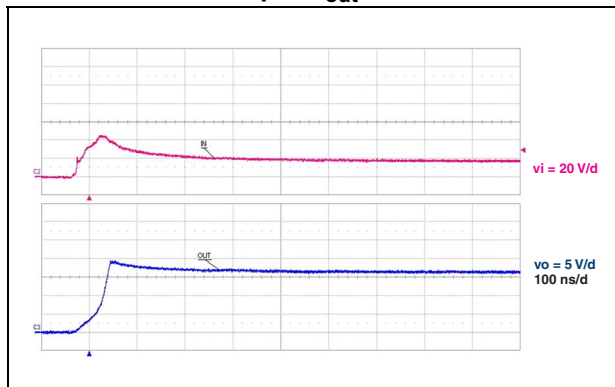
**Figure 13. ESD response to IEC 61000-4-2 (+15 kV air discharge) on input  $V_{in}$  and output  $V_{out}$  Mic1 line**



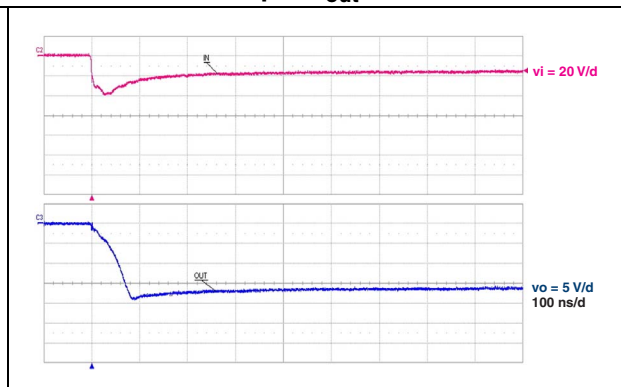
**Figure 14. ESD response to IEC 61000-4-2 (-15 kV air discharge) on input  $V_{in}$  and output  $V_{out}$  Mic1 line**



**Figure 15. ESD response to IEC 61000-4-2 (+15 kV air discharge) on input  $V_{in}$  and output  $V_{out}$  Mic2 line**



**Figure 16. ESD response to IEC 61000-4-2 (-15 kV air discharge) on input  $V_{in}$  and output  $V_{out}$  Mic2 line**



### 1.4 Filter characteristics

Figure 17. Analog crosstalk MIC2\_P and MIC1\_N lines (50 Ω / 50 Ω)

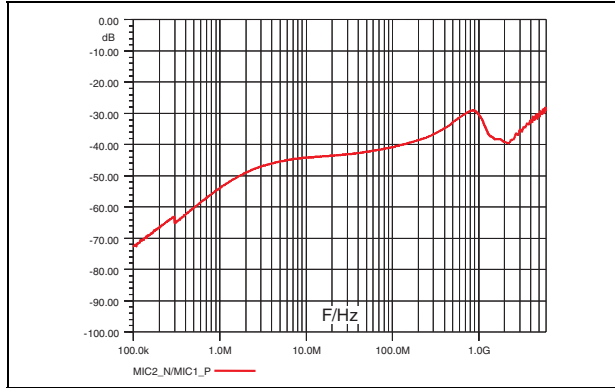
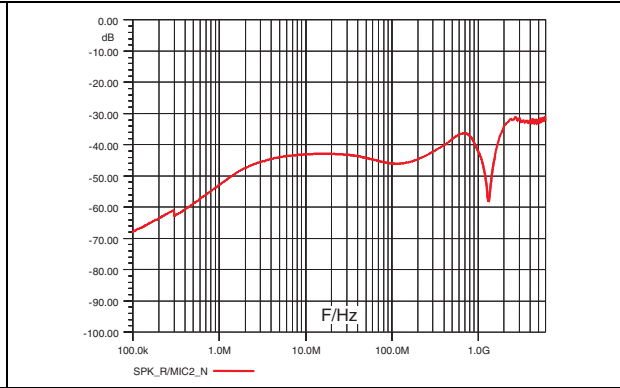


Figure 18. Analog crosstalk SPK\_R and MIC2\_N lines (50 Ω / 50 Ω)



### 1.5 Total harmonic distortion characteristics

Figure 19. Total harmonic distortion and noise with only cables and environmental circuit versus frequency,  $V_{BIAS} = 0 V$

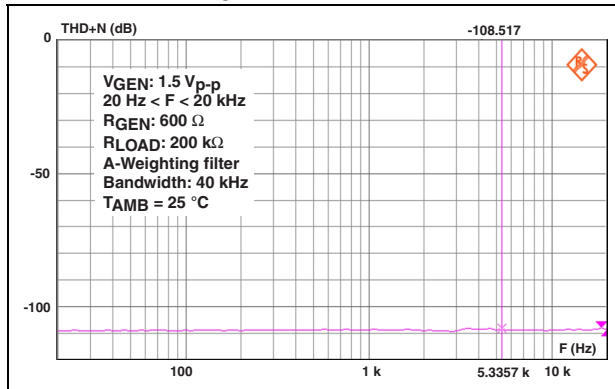


Figure 20. Variation of total harmonic distortion and noise in microphone lines versus frequency, balanced (or differential) mode,  $V_{BIAS} = 0 V$

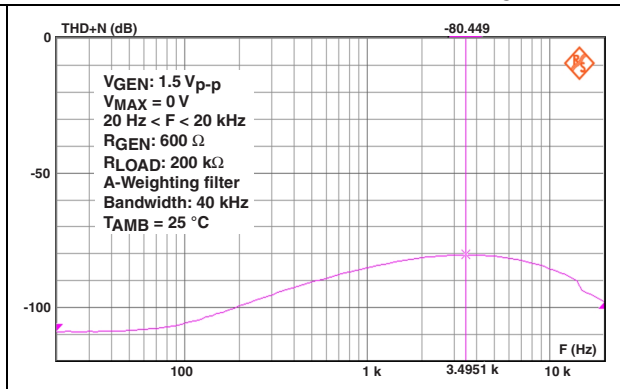


Figure 21. Variation of total harmonic distortion and noise in microphone lines versus frequency, balanced (or differential) mode,  $V_{BIAS} = 2.4\text{ V}$

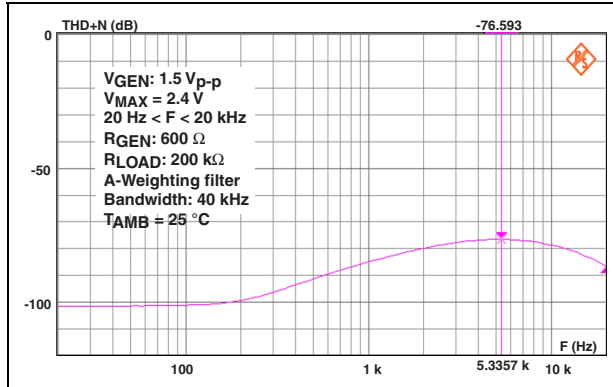


Figure 22. Variation of total harmonic distortion and noise in microphone lines versus frequency, unbalanced (or single-ended) mode

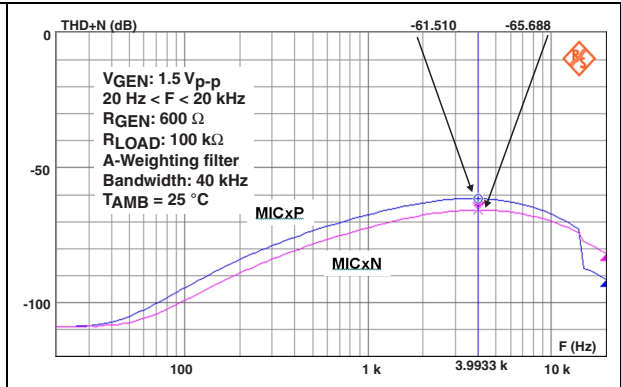


Figure 23. Test setup for measurement of distortion on MIC channels

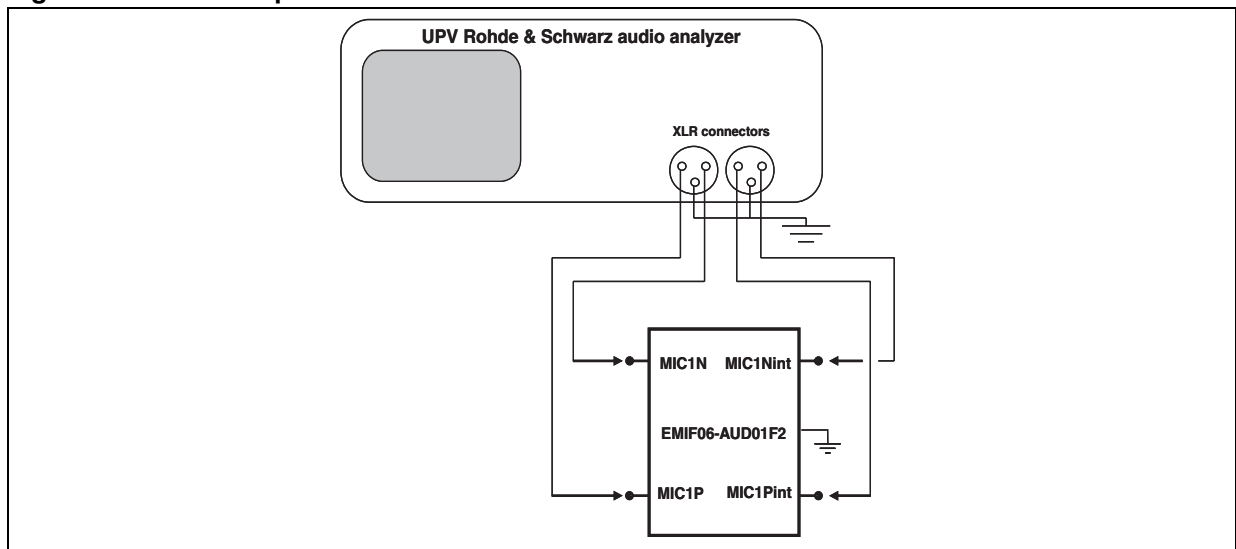
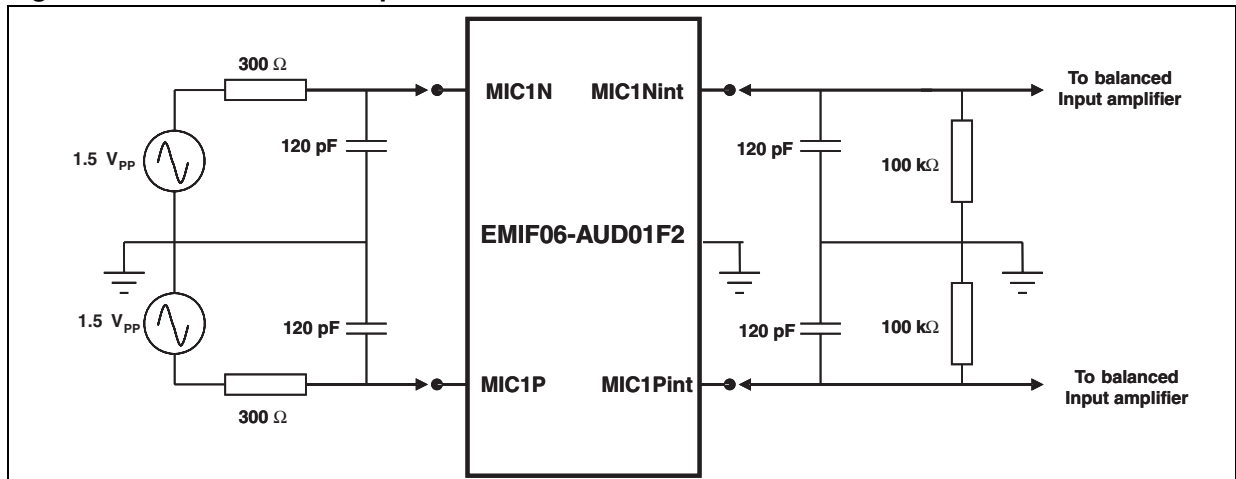


Figure 24. Internal UPV setup schematic



## 2 Application schematics

Figure 25. Basic configuration scheme

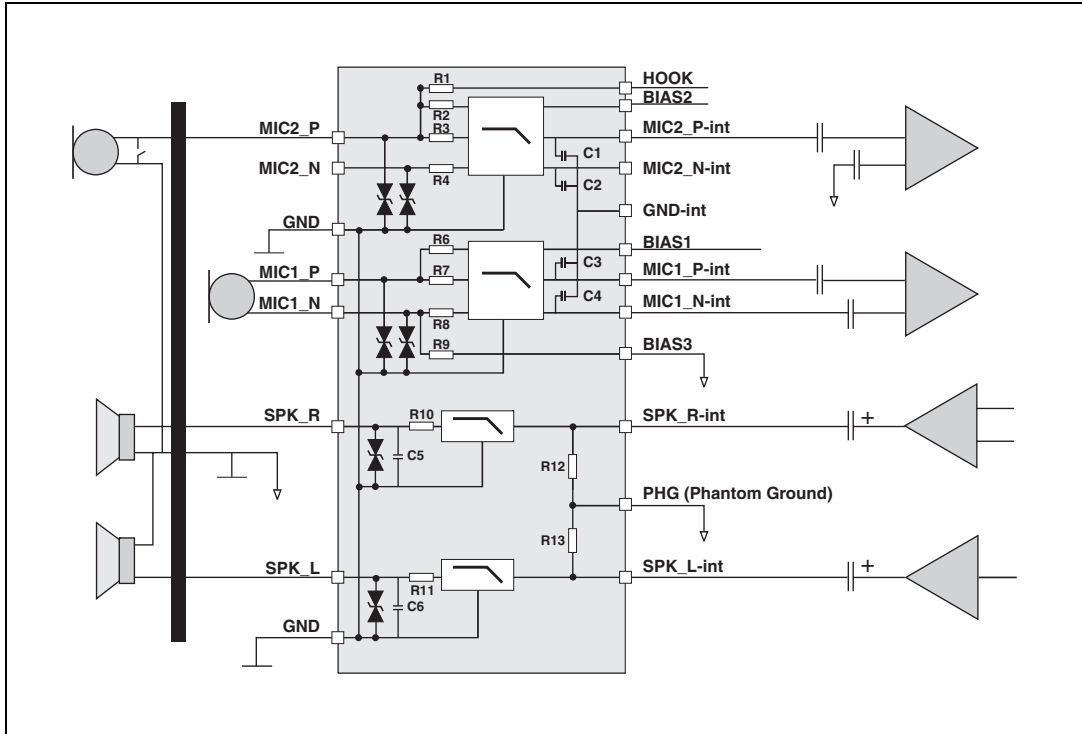


Figure 26. Stereo line in

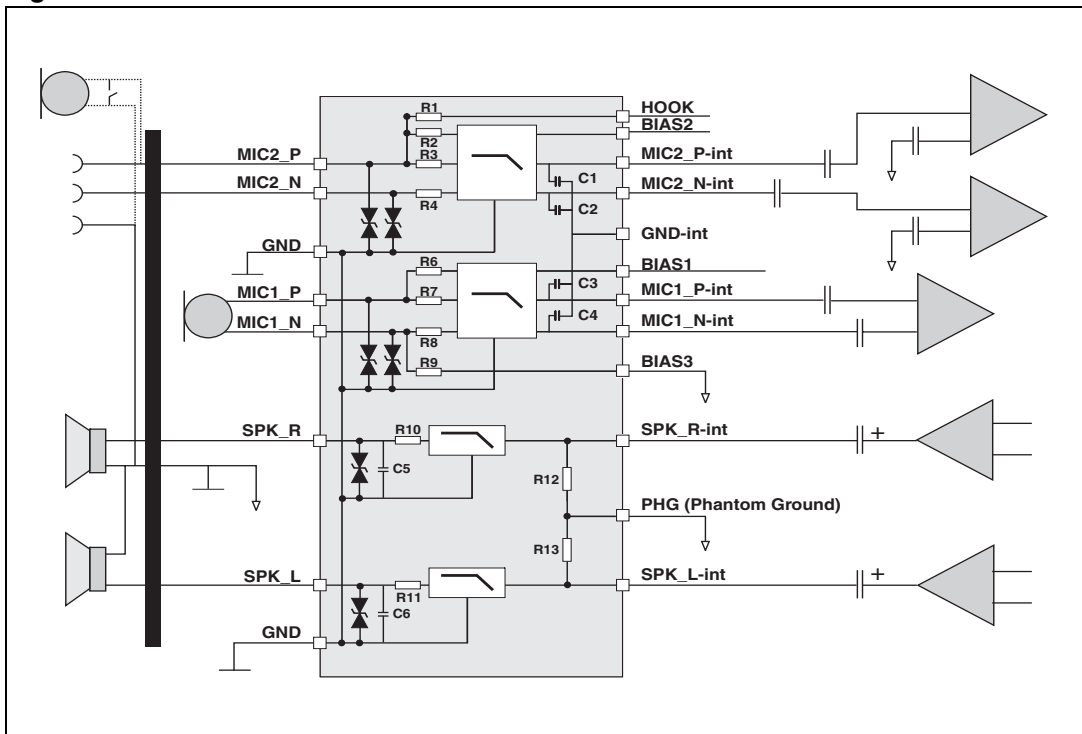


Figure 27. Stereo microphone / line in

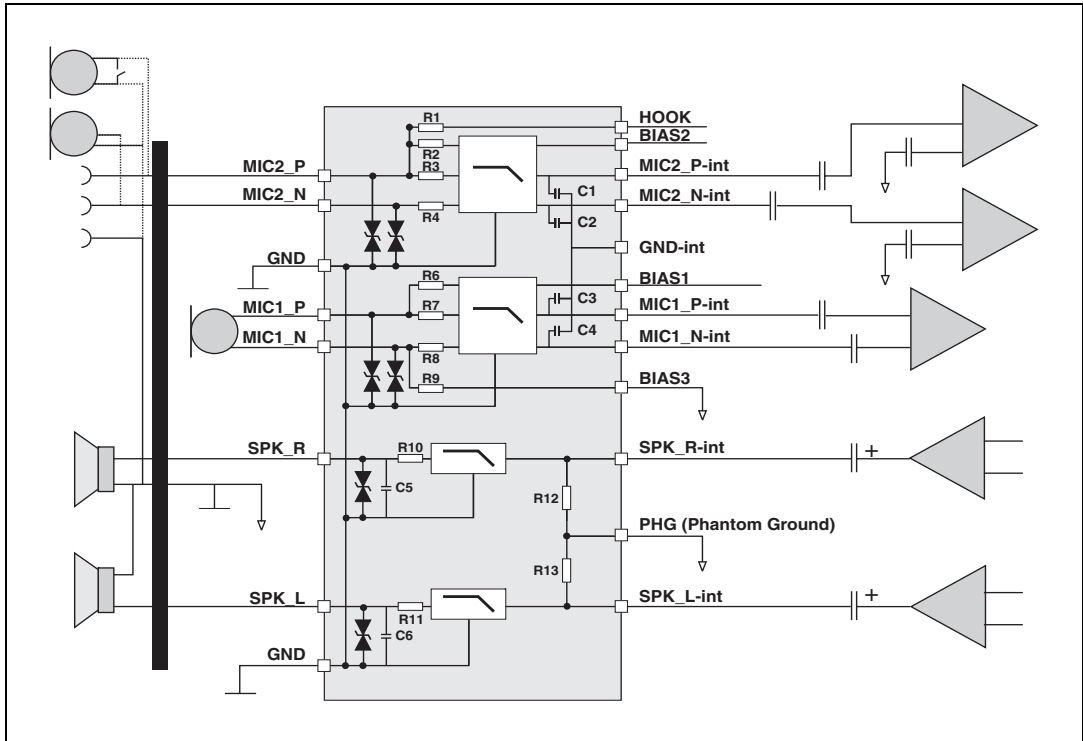
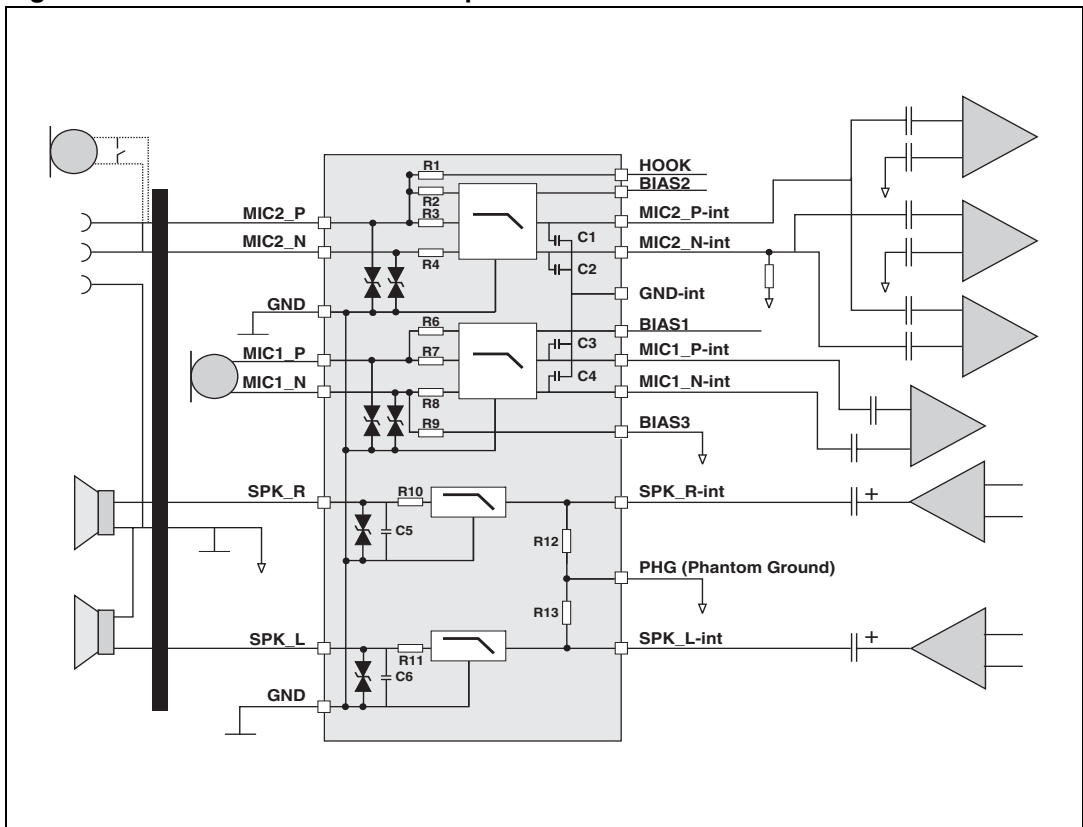
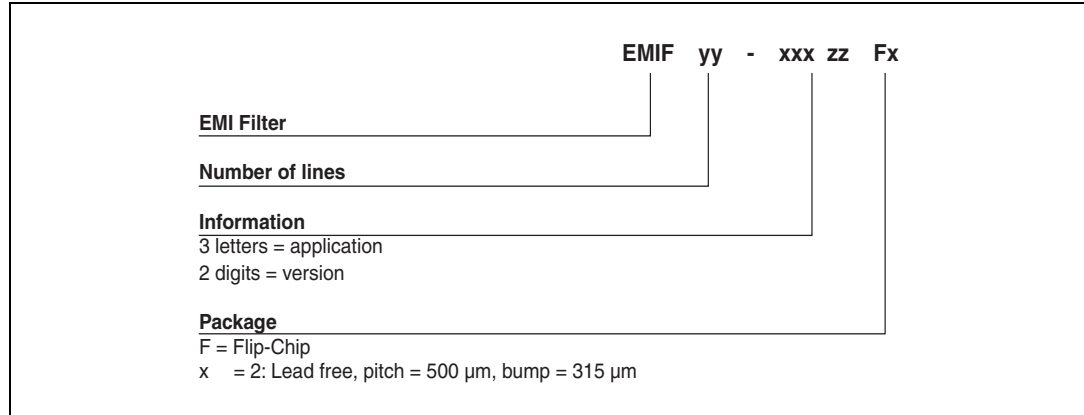


Figure 28. External balanced microphone / stereo line in



### 3 Ordering information scheme

Figure 29. Ordering information scheme



### 4 Package information

In order to meet environmental requirements, ST offers these devices in ECOPACK® packages. These packages have a lead-free second level interconnect. The category of second level interconnect is marked on the inner box label, in compliance with JEDEC Standard JESD97. The maximum ratings related to soldering conditions are also marked on the inner box label. ECOPACK is an ST trademark. ECOPACK specifications are available at [www.st.com](http://www.st.com).

Figure 30. Flip chip dimensions

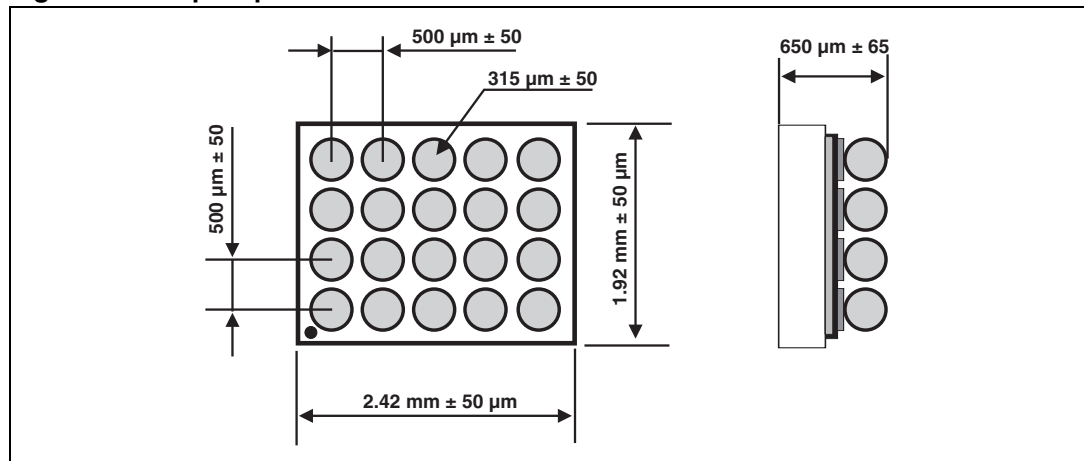


Figure 31. Marking

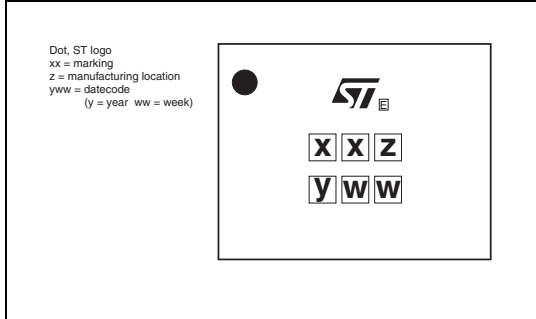


Figure 32. Footprint recommendation

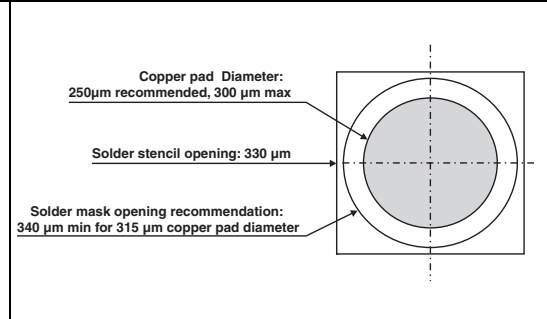
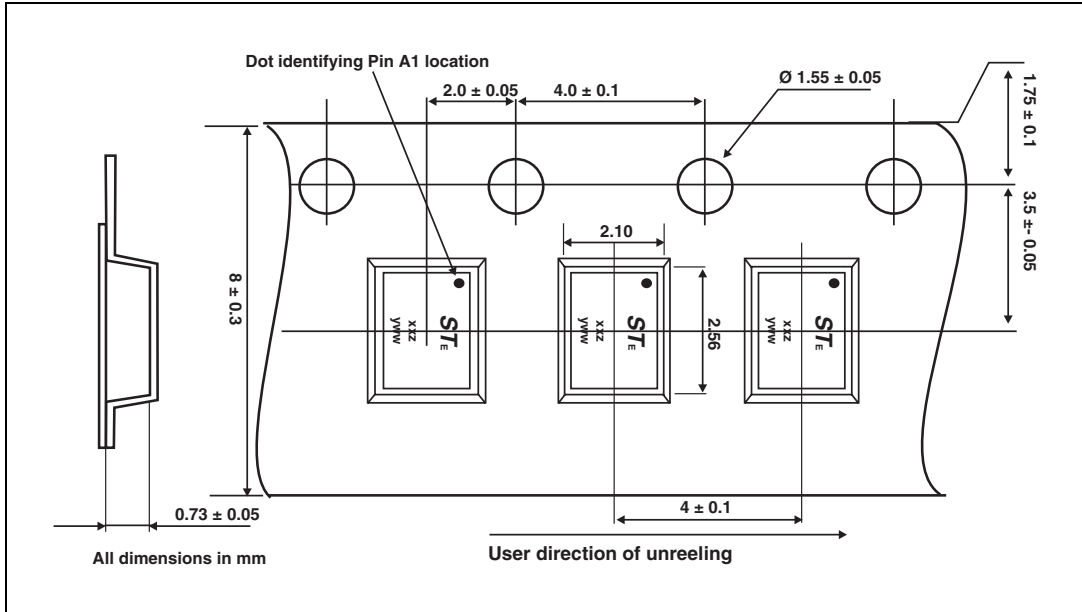


Figure 33. Flip chip tape and reel specification



Note: More packing information is available in the application notes:  
 AN1235: "Flip chip: Package description and recommendations for use"  
 AN1751: "EMI Filters: Recommendations and measurements"

## 5 Ordering information

Table 6. Ordering information

Ordering code	Marking	Package	Weight	Base qty	Delivery mode
EMIF06-AUD01F2	HP	Flip chip	6.45 mg	5000	7" Tape and reel

## 6 Revision history

Table 7. Document revision history

Date	Revision	Changes
18-Feb-2008	1	First issue

**Please Read Carefully:**

Information in this document is provided solely in connection with ST products. STMicroelectronics NV and its subsidiaries ("ST") reserve the right to make changes, corrections, modifications or improvements, to this document, and the products and services described herein at any time, without notice.

All ST products are sold pursuant to ST's terms and conditions of sale.

Purchasers are solely responsible for the choice, selection and use of the ST products and services described herein, and ST assumes no liability whatsoever relating to the choice, selection or use of the ST products and services described herein.

No license, express or implied, by estoppel or otherwise, to any intellectual property rights is granted under this document. If any part of this document refers to any third party products or services it shall not be deemed a license grant by ST for the use of such third party products or services, or any intellectual property contained therein or considered as a warranty covering the use in any manner whatsoever of such third party products or services or any intellectual property contained therein.

**UNLESS OTHERWISE SET FORTH IN ST'S TERMS AND CONDITIONS OF SALE ST DISCLAIMS ANY EXPRESS OR IMPLIED WARRANTY WITH RESPECT TO THE USE AND/OR SALE OF ST PRODUCTS INCLUDING WITHOUT LIMITATION IMPLIED WARRANTIES OF MERCHANTABILITY, FITNESS FOR A PARTICULAR PURPOSE (AND THEIR EQUIVALENTS UNDER THE LAWS OF ANY JURISDICTION), OR INFRINGEMENT OF ANY PATENT, COPYRIGHT OR OTHER INTELLECTUAL PROPERTY RIGHT.**

**UNLESS EXPRESSLY APPROVED IN WRITING BY AN AUTHORIZED ST REPRESENTATIVE, ST PRODUCTS ARE NOT RECOMMENDED, AUTHORIZED OR WARRANTED FOR USE IN MILITARY, AIR CRAFT, SPACE, LIFE SAVING, OR LIFE SUSTAINING APPLICATIONS, NOR IN PRODUCTS OR SYSTEMS WHERE FAILURE OR MALFUNCTION MAY RESULT IN PERSONAL INJURY, DEATH, OR SEVERE PROPERTY OR ENVIRONMENTAL DAMAGE. ST PRODUCTS WHICH ARE NOT SPECIFIED AS "AUTOMOTIVE GRADE" MAY ONLY BE USED IN AUTOMOTIVE APPLICATIONS AT USER'S OWN RISK.**

Resale of ST products with provisions different from the statements and/or technical features set forth in this document shall immediately void any warranty granted by ST for the ST product or service described herein and shall not create or extend in any manner whatsoever, any liability of ST.

ST and the ST logo are trademarks or registered trademarks of ST in various countries.

Information in this document supersedes and replaces all information previously supplied.

The ST logo is a registered trademark of STMicroelectronics. All other names are the property of their respective owners.

© 2008 STMicroelectronics - All rights reserved

STMicroelectronics group of companies

Australia - Belgium - Brazil - Canada - China - Czech Republic - Finland - France - Germany - Hong Kong - India - Israel - Italy - Japan - Malaysia - Malta - Morocco - Singapore - Spain - Sweden - Switzerland - United Kingdom - United States of America

[www.st.com](http://www.st.com)