



EMIF10-1K010F2

10-line IPAD™, EMI filter including ESD protection

Features

- EMI symmetrical (I/O) low-pass filter
- High efficiency in EMI filtering
- Lead free package
- Very low PCB space consuming: 2.42 mm x 2.42 mm
- Very thin package: 0.650 mm
- High efficiency in ESD suppression on both input and output pins (IEC 61000-4-2 level 4)
- High reliability offered by monolithic integration
- High reducing of parasitic elements through integration & wafer level packaging

Complies with the following standards:

- IEC 61000-4-2 level 4
 - 15 kV (air discharge)
 - 8 kV (contact discharge)
- MIL STD 883F - Method 3015.7 Class 3

Applications

Where EMI filtering in ESD sensitive equipment is required:

- Mobile Phones
- Computers and printers
- Communication systems
- MCU Boards

Description

The EMIF10-1K010F2 is a highly integrated device designed to suppress EMI / RFI noise in all systems subjected to electromagnetic interferences. The EMIF10 Flip-Chip packaging means the package size is equal to the die size.

Additionally, this filter includes an ESD protection circuitry which prevents damage to the application when subjected to ESD surges up to 15 kV.

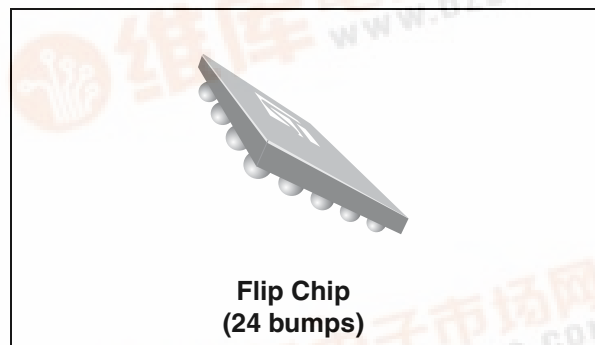

Figure 1. Pin configuration (bump side)

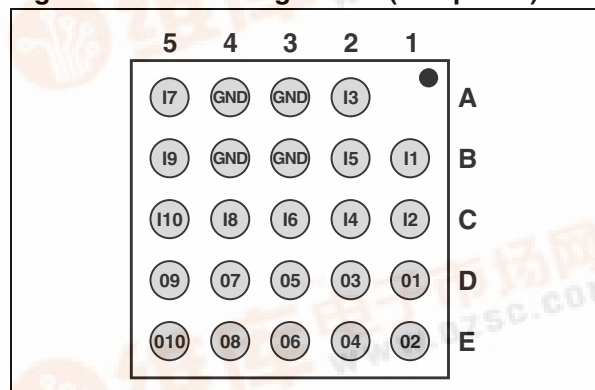
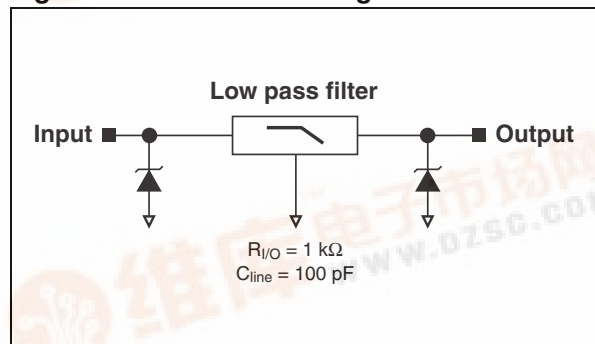

Figure 2. Basic cell configuration



TM: IPAD is a trademark of STMicroelectronics.



1 Characteristics

Table 1. Absolute ratings ($T_{amb} = 25\text{ °C}$)

Symbol	Parameter and test conditions	Value	Unit
V_{PP}	ESD discharge IEC 61000-4-2		
	– Air discharge	15	kV
	– Contact discharge	8	
MIL STD 883F - Method 3015.7 Class 3	25		
T_j	Junction temperature	125	°C
T_{op}	Operating temperature range	- 40 to + 85	°C
T_{stg}	Storage temperature range	- 55 to + 150	°C

Table 2. Electrical characteristics ($T_{amb} = 25\text{ °C}$)

Symbol	Parameter				
V_{BR}	Breakdown voltage				
I_{RM}	Leakage current @ V_{RM}				
V_{RM}	Stand-off voltage				
V_{CL}	Clamping voltage				
R_d	Dynamic impedance				
I_{PP}	Peak pulse current				
$R_{I/O}$	Resistance between Input and Output				
C_{line}	Input capacitance per line				
Symbol	Test conditions	Min.	Typ.	Max.	Unit
V_{BR}	$I_R = 1\text{ mA}$	6	8	10	V
I_{RM}	$V_{RM} = 3\text{ V per line}$			200	nA
R_d	$I_{PP} = 10\text{ A}, t_p = 2.5\text{ }\mu\text{s}$		1		Ω
$R_{I/O}$		900	1000	1100	Ω
C_{line}	$F = 1\text{ MHz } V_{OSC} = 30\text{ mV } V_{line} = 0\text{ V}$	80	100	120	pF

Figure 3. S21(db) attenuation measurement

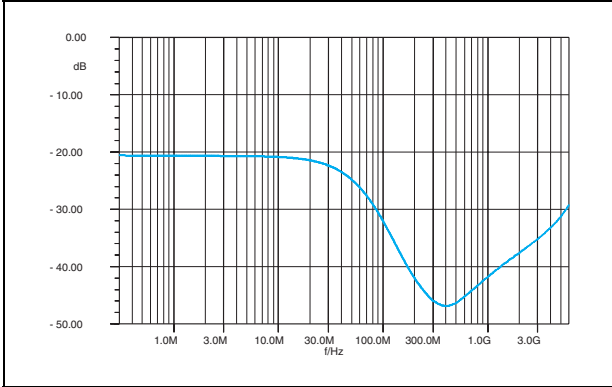

Figure 4. Analog cross talk measurements

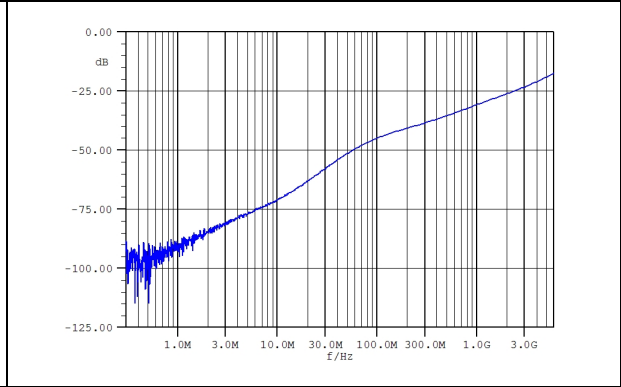

Figure 5. ESD response to IEC 61000-4-2 (+15 kV air discharge) on one input (V_{in}) and on one output (V_{out})

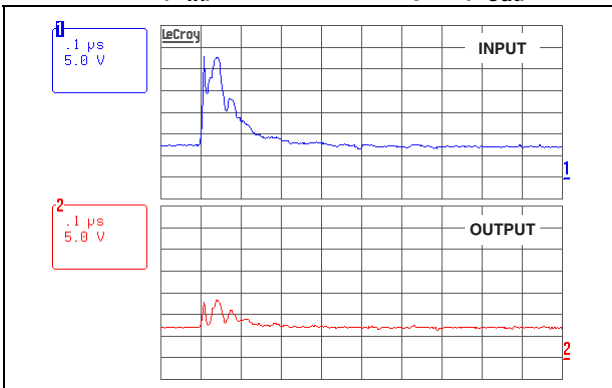

Figure 6. ESD response to IEC 61000-4-2 (-15 kV air discharge) on one input (V_{in}) and on one output (V_{out})

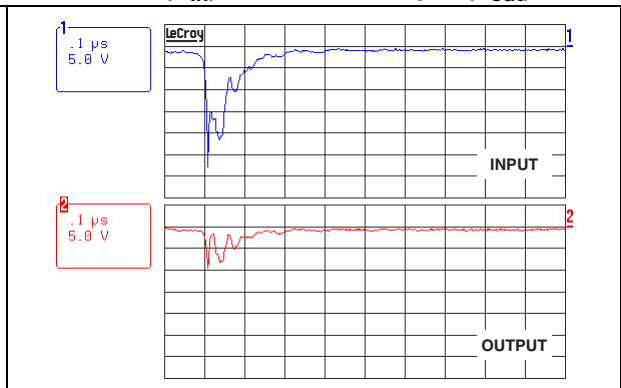
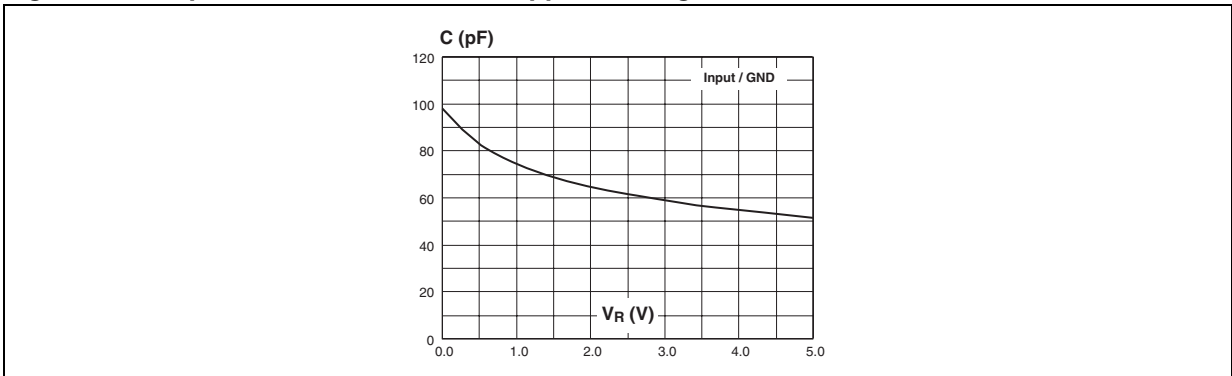

Figure 7. Capacitance versus reverse applied voltage



2 Application information

Figure 8. Aplac model

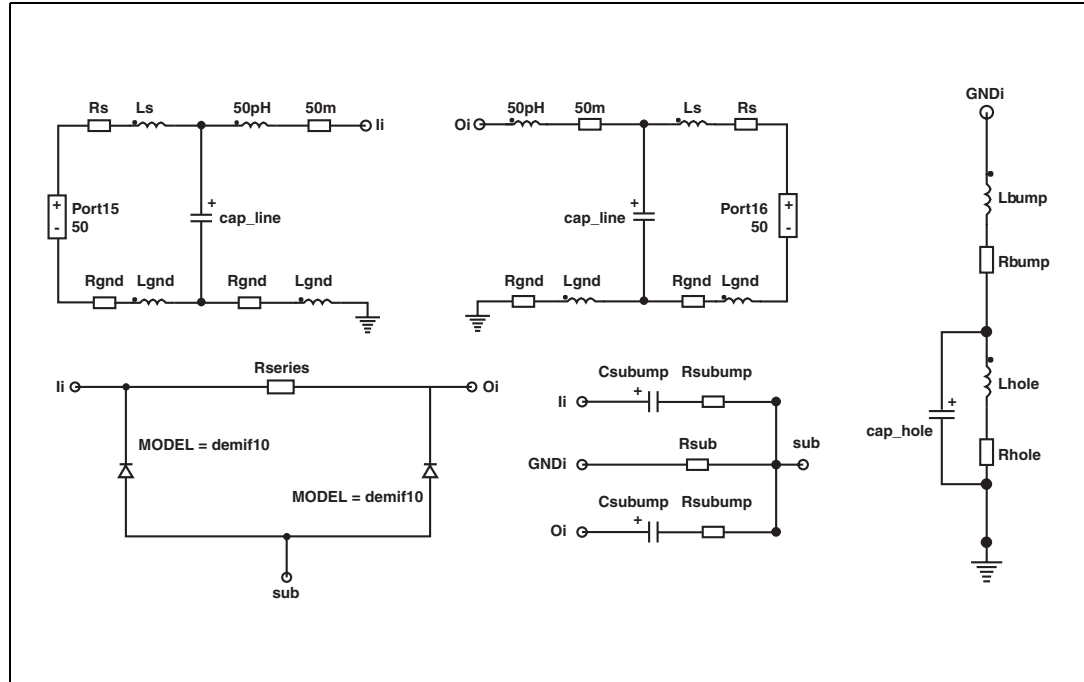
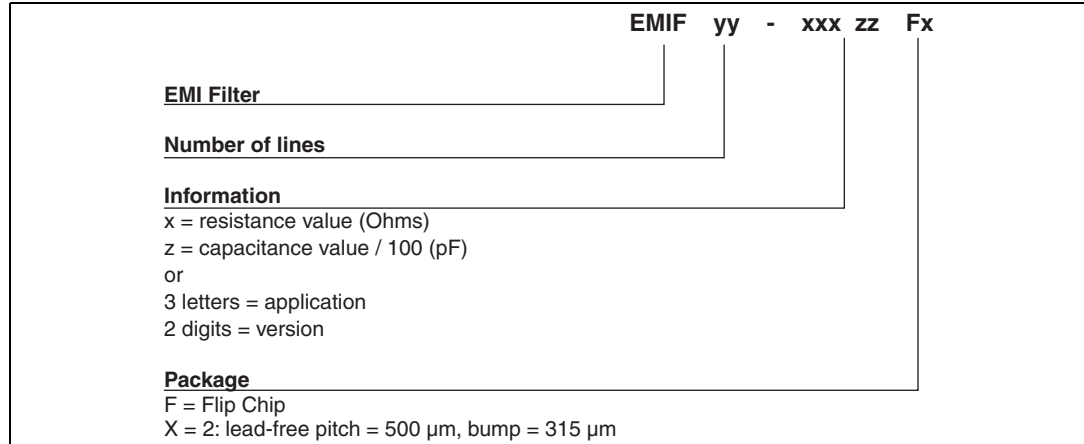

Figure 9. Aplac parameters

Cz	57pF	Model demif10
Rseries	960	BV = 7
cap_line	0.8pF	IBV = 1m
Ls	0.6nH	CJO = Cz
Rbump	50m	M = 0.3333
Lbump	50pH	Rs = 1
Rs	0.15	VJ = 0.6
Csubump	15pF	TT = 100n
Rsubump	0.15	
Rsub	0.1	
lhole	1.2nH opt	
Rhole	0.15	
cap_hole	0.15pF	
Rgnd	0.25	
Lgnd	0.4nH	

3 Ordering information scheme

Figure 10. Ordering information scheme



4 Package information

In order to meet environmental requirements, ST offers these devices in ECOPACK® packages. These packages have a lead-free second level interconnect. The category of second level interconnect is marked on the inner box label, in compliance with JEDEC Standard JESD97. The maximum ratings related to soldering conditions are also marked on the inner box label. ECOPACK is an ST trademark. ECOPACK specifications are available at www.st.com.

Figure 11. Flip Chip package dimensions

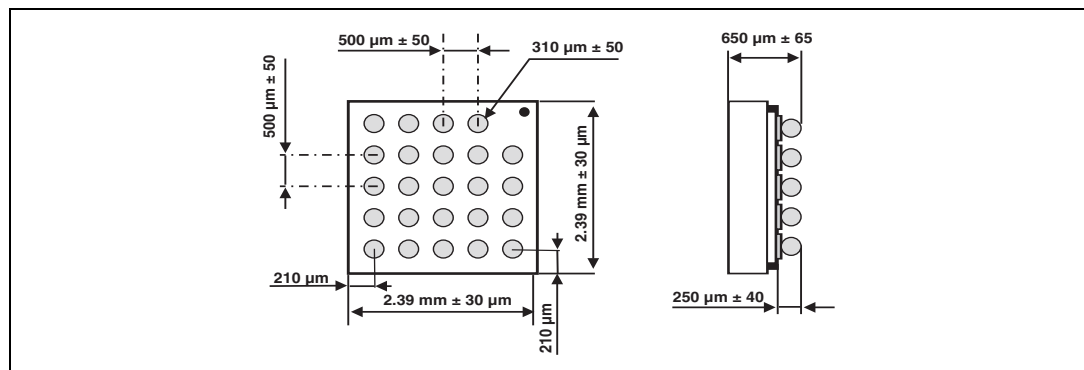

Figure 12. Footprint recommendations Figure 13. Marking

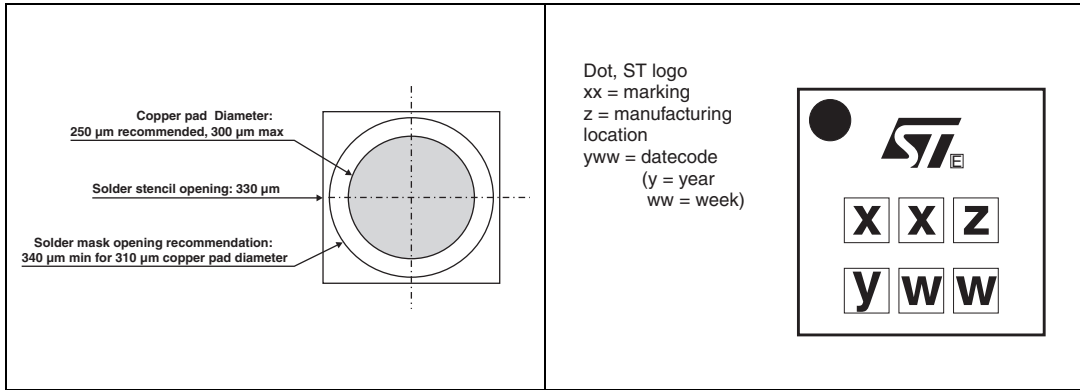
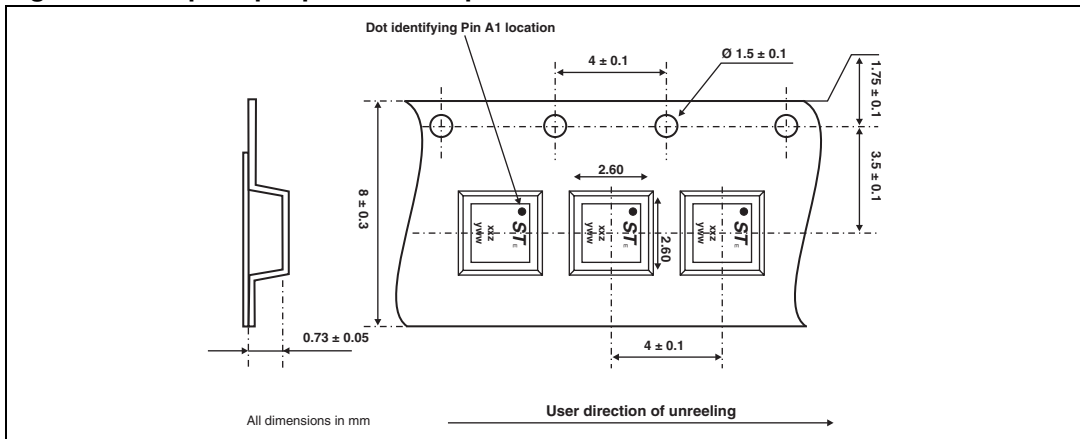

Figure 14. Flip Chip tape and reel specification



5 Ordering information

Table 3. Ordering information

Order code	Marking	Package	Weight	Base qty	Delivery mode
EMIF10-1K010F2	FD	Flip Chip	7.9 mg	5000	Tape and reel

Note:

More information is available in the application notes:

AN1235: "Flip Chip: Package description and recommendations for use"

AN1751: "EMI Filters: Recommendations and measurements"

6 Revision history

Table 4. Document revision history

Date	Revision	Description of changes
12-Oct-2004	1	First issue.
28-Aug-2006	2	Die layout upgrade.
18-Sep-2006	3	Added pocket dimensions to Figure 11.
17-Apr-2008	4	Updated ECOPACK statement. Updated Figure 10 , Figure 11 , Figure 12 , and Figure 14 . Reformatted to current standards.

Please Read Carefully:

Information in this document is provided solely in connection with ST products. STMicroelectronics NV and its subsidiaries ("ST") reserve the right to make changes, corrections, modifications or improvements, to this document, and the products and services described herein at any time, without notice.

All ST products are sold pursuant to ST's terms and conditions of sale.

Purchasers are solely responsible for the choice, selection and use of the ST products and services described herein, and ST assumes no liability whatsoever relating to the choice, selection or use of the ST products and services described herein.

No license, express or implied, by estoppel or otherwise, to any intellectual property rights is granted under this document. If any part of this document refers to any third party products or services it shall not be deemed a license grant by ST for the use of such third party products or services, or any intellectual property contained therein or considered as a warranty covering the use in any manner whatsoever of such third party products or services or any intellectual property contained therein.

UNLESS OTHERWISE SET FORTH IN ST'S TERMS AND CONDITIONS OF SALE ST DISCLAIMS ANY EXPRESS OR IMPLIED WARRANTY WITH RESPECT TO THE USE AND/OR SALE OF ST PRODUCTS INCLUDING WITHOUT LIMITATION IMPLIED WARRANTIES OF MERCHANTABILITY, FITNESS FOR A PARTICULAR PURPOSE (AND THEIR EQUIVALENTS UNDER THE LAWS OF ANY JURISDICTION), OR INFRINGEMENT OF ANY PATENT, COPYRIGHT OR OTHER INTELLECTUAL PROPERTY RIGHT.

UNLESS EXPRESSLY APPROVED IN WRITING BY AN AUTHORIZED ST REPRESENTATIVE, ST PRODUCTS ARE NOT RECOMMENDED, AUTHORIZED OR WARRANTED FOR USE IN MILITARY, AIR CRAFT, SPACE, LIFE SAVING, OR LIFE SUSTAINING APPLICATIONS, NOR IN PRODUCTS OR SYSTEMS WHERE FAILURE OR MALFUNCTION MAY RESULT IN PERSONAL INJURY, DEATH, OR SEVERE PROPERTY OR ENVIRONMENTAL DAMAGE. ST PRODUCTS WHICH ARE NOT SPECIFIED AS "AUTOMOTIVE GRADE" MAY ONLY BE USED IN AUTOMOTIVE APPLICATIONS AT USER'S OWN RISK.

Resale of ST products with provisions different from the statements and/or technical features set forth in this document shall immediately void any warranty granted by ST for the ST product or service described herein and shall not create or extend in any manner whatsoever, any liability of ST.

ST and the ST logo are trademarks or registered trademarks of ST in various countries.

Information in this document supersedes and replaces all information previously supplied.

The ST logo is a registered trademark of STMicroelectronics. All other names are the property of their respective owners.

© 2008 STMicroelectronics - All rights reserved

STMicroelectronics group of companies

Australia - Belgium - Brazil - Canada - China - Czech Republic - Finland - France - Germany - Hong Kong - India - Israel - Italy - Japan - Malaysia - Malta - Morocco - Singapore - Spain - Sweden - Switzerland - United Kingdom - United States of America

www.st.com