



# EMIF10-COM01F2

## 10-line IPAD™, EMI filter including ESD protection

### Features

- EMI symmetrical (I/O) low-pass filter
- Lead free package
- Very low PCB space consuming: <math>< 6 \text{ mm}^2</math>
- Very thin package: 0.65 mm
- High efficiency in ESD suppression on both input & output pins
- High reliability offered by monolithic integration

### Complies with the following standard:

- IEC 61000-4-2 level 4
  - 15 kV (air discharge)
  - 8 kV (contact discharge)

### Applications

EMI filtering and ESD protection for:

- Computers and printers
- Communication systems
- Mobile phones

### Description

The EMIF10-COM01F2 is a highly integrated device designed to suppress EMI / RFI noise in all systems subjected to electromagnetic interferences. The EMIF10 Flip-Chip packaging means the package size is equal to the die size.

Additionally, this filter includes an ESD protection circuitry which prevents damage to the application when subjected to ESD surges up to 15 kV.

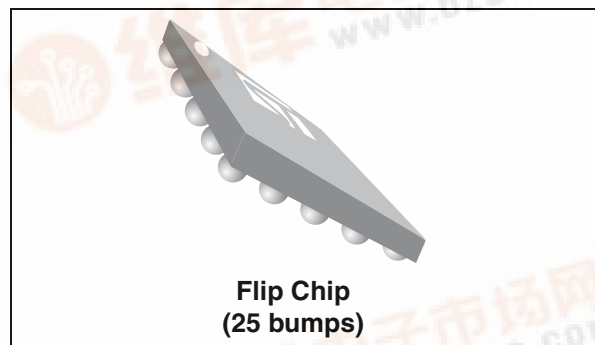


Figure 1. Pin configuration (bump side)

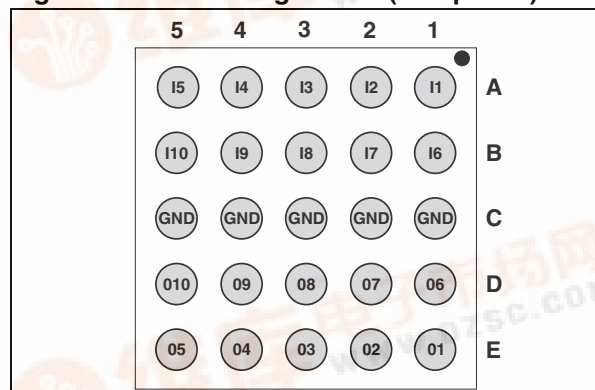
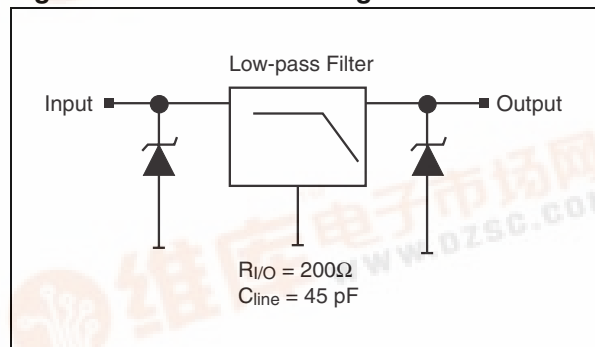


Figure 2. Basic cell configuration



TM: IPAD is a trademark of STMicroelectronics.



# 1 Characteristics

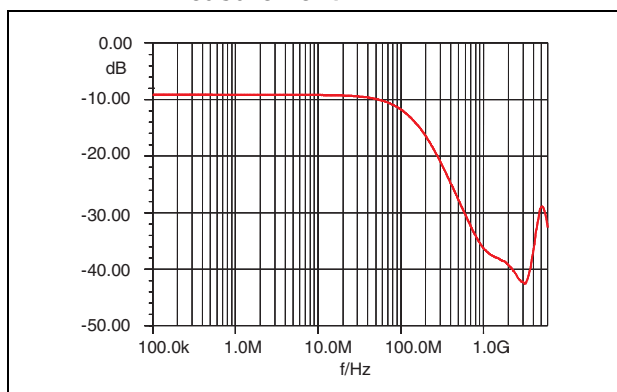
**Table 1. Absolute ratings ( $T_{amb} = 25\text{ }^{\circ}\text{C}$ )**

Symbol	Parameter and test conditions	Value	Unit
$V_{PP}$	ESD discharge IEC61000-4-2, air discharge	15	kV
	ESD discharge IEC61000-4-2, contact discharge	8	
$T_j$	Junction temperature	125	$^{\circ}\text{C}$
$T_{op}$	Operating temperature range	- 40 to + 85	$^{\circ}\text{C}$
$T_{stg}$	Storage temperature range	- 55 to + 150	$^{\circ}\text{C}$

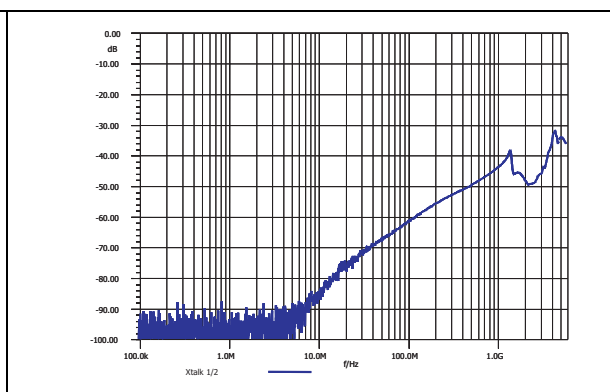
**Table 2. Electrical characteristics ( $T_{amb} = 25\text{ }^{\circ}\text{C}$ )**

Symbol	Parameter				
$V_{BR}$	Breakdown voltage				
$I_{RM}$	Leakage current @ $V_{RM}$				
$V_{RM}$	Stand-off voltage				
$V_{CL}$	Clamping voltage				
$R_d$	Dynamic impedance				
$I_{PP}$	Peak pulse current				
$R_{I/O}$	Resistance between Input and Output				
$C_{line}$	Input capacitance per line				
Symbol	Test conditions	Min.	Typ.	Max.	Unit
$V_{BR}$	$I_R = 1\text{ mA}$	6	8	10	V
$I_{RM}$	$V_{RM} = 3\text{ V per line}$			500	nA
$R_d$	$I_{PP} = 10\text{ A}, t_p = 2.5\text{ }\mu\text{s}$		1		$\Omega$
$R_{I/O}$		180	200	220	$\Omega$
$C_{line}$	At 0 V bias		45	50	pF
$t_{LH}$	$V_{input} = 2.8\text{ V}$ $R_{load} = 100\text{ k}\Omega$			25	ns

**Figure 3. S21(db) attenuation measurement<sup>(1)</sup>**

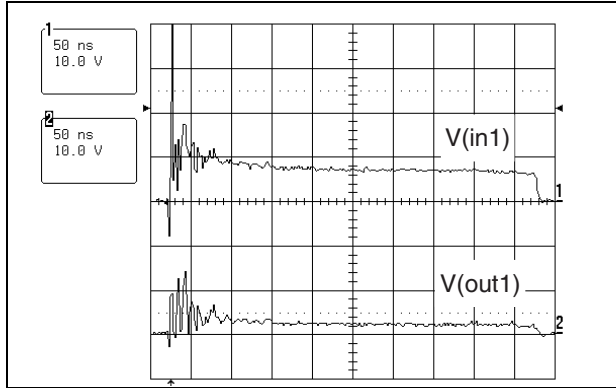


**Figure 4. Analog crosstalk**

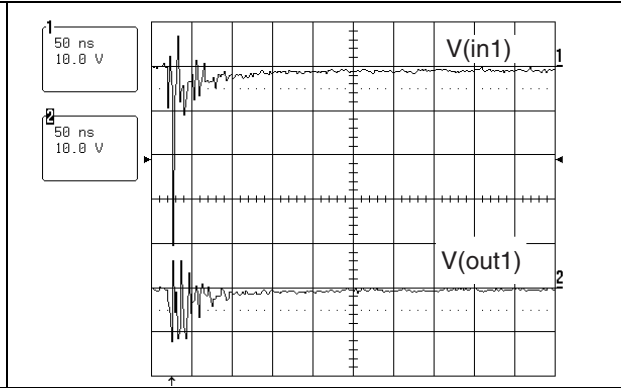


1. Spikes at high frequencies are induced by the PCB layout

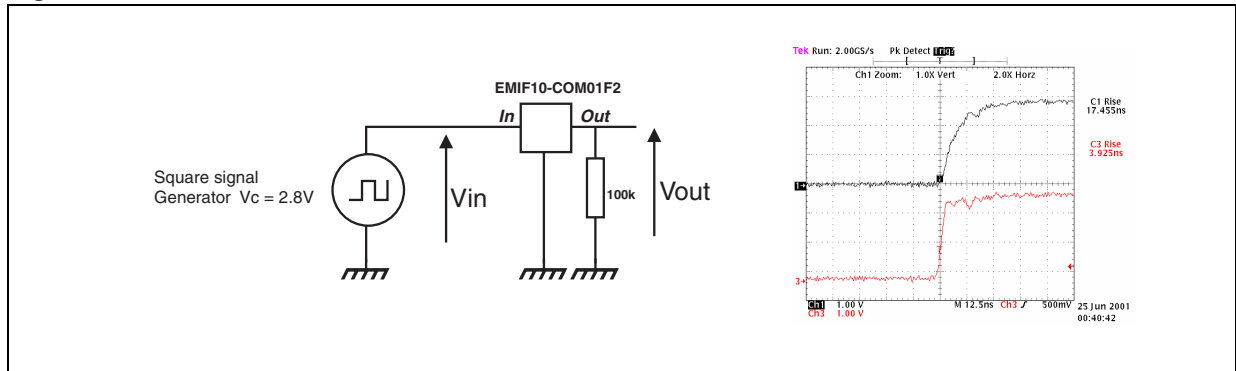
**Figure 5. ESD response to IEC 61000-4-2 (+15 kV air discharge) on one input ( $V_{in}$ ) and on one output ( $V_{out}$ )**



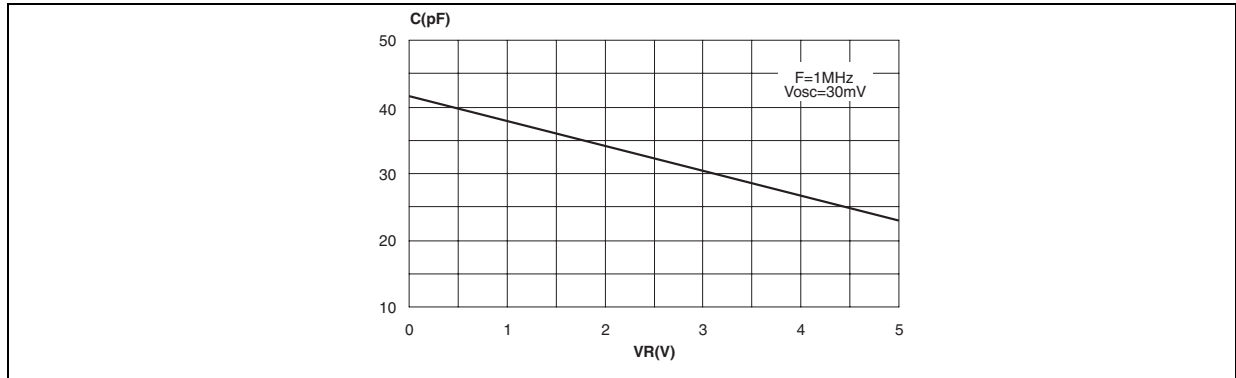
**Figure 6. ESD response to IEC 61000-4-2 (-15 kV air discharge) on one input ( $V_{in}$ ) and on one output ( $V_{out}$ )**



**Figure 7. Rise time measurement**

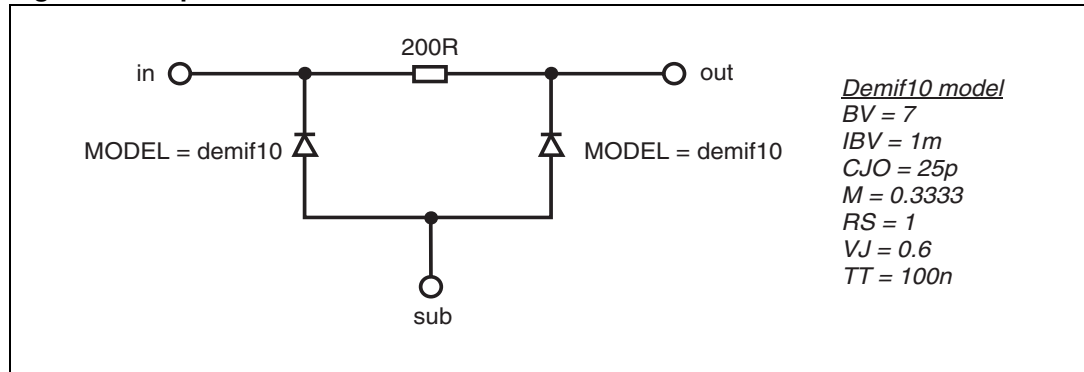


**Figure 8. Capacitance versus reverse applied voltage**



## 2 Application information

Figure 9. Aplac model

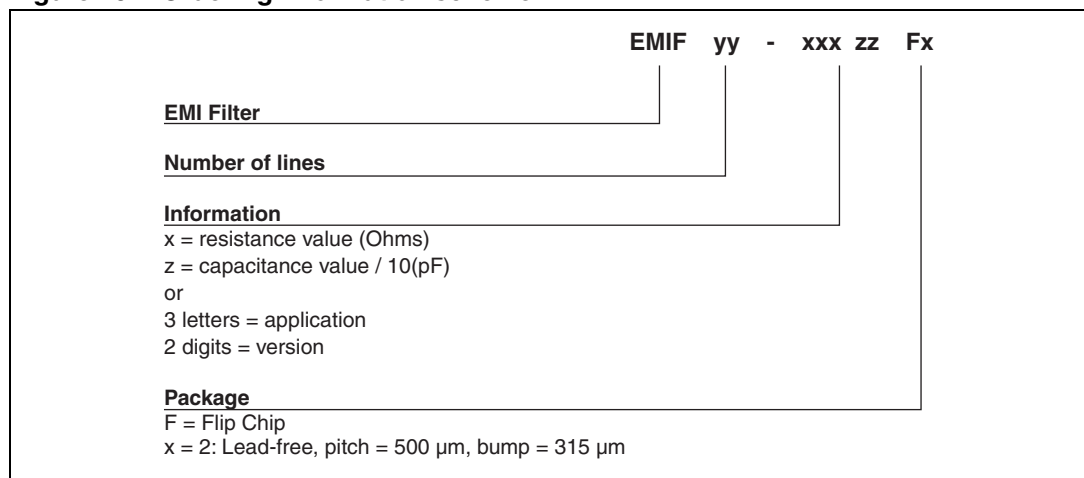


### 2.1 PCB grounding recommendations

In order to ensure a good efficiency in terms of ESD protection and filtering behavior, we recommend to implement microvias (100 μm dia.) between the GND bumps and the GND layer. GND bumps can be connected together in PCB layer 1, and in addition, if possible, use through hole vias (200 μm dia.) in both sides of filter to improve contact to GND (layer). This layout will minimize the distance to the ground and thus parasitic inductances. In addition, we recommend to have GND plane wherever possible.

## 3 Ordering information scheme

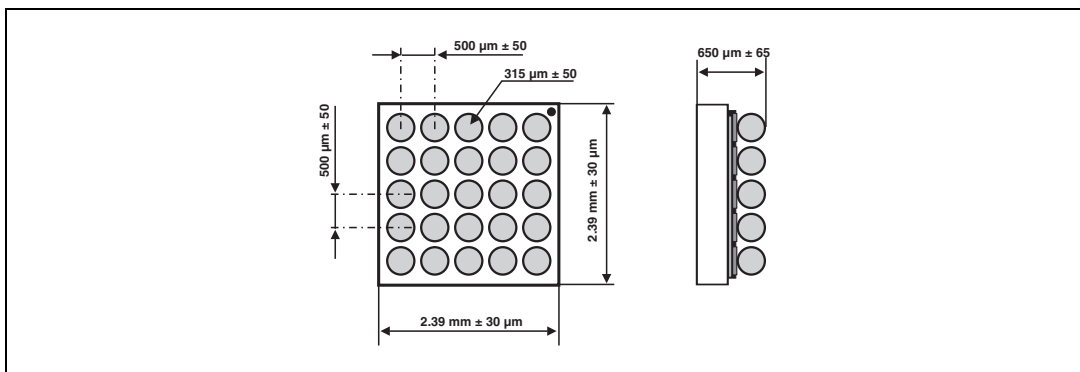
Figure 10. Ordering information scheme



## 4 Package information

In order to meet environmental requirements, ST offers these devices in ECOPACK® packages. These packages have a lead-free second level interconnect. The category of second level interconnect is marked on the inner box label, in compliance with JEDEC Standard JESD97. The maximum ratings related to soldering conditions are also marked on the inner box label. ECOPACK is an ST trademark. ECOPACK specifications are available at [www.st.com](http://www.st.com).

**Figure 11. Flip Chip package dimensions**



**Figure 12. Footprint recommendations**      **Figure 13. Marking**

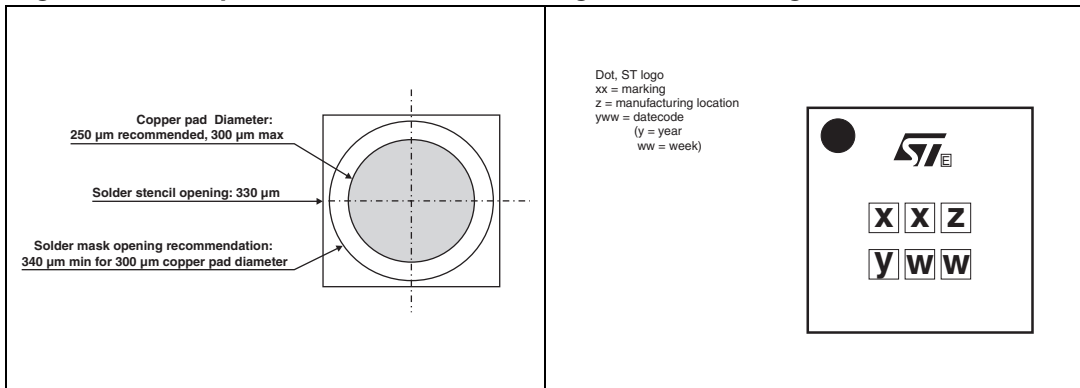
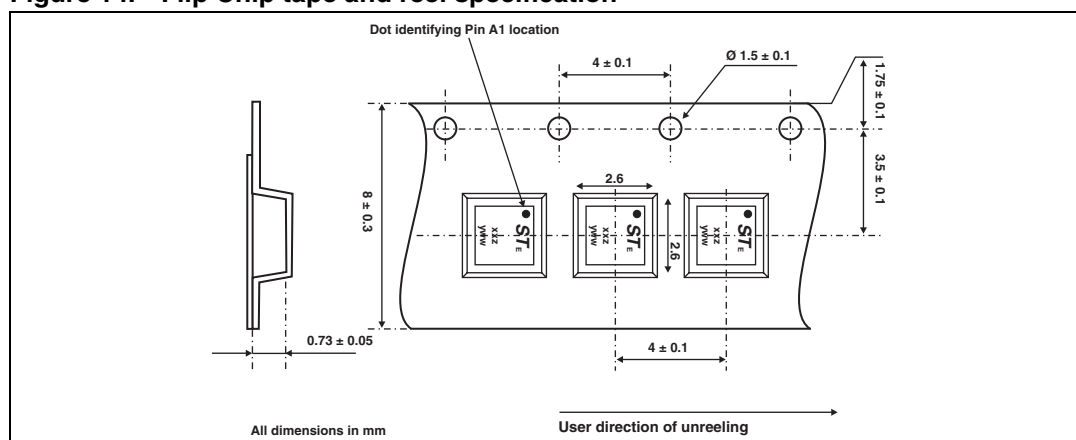


Figure 14. Flip Chip tape and reel specification



## 5 Ordering information

Table 3. Ordering information

Order code	Marking	Package	Weight	Base qty	Delivery mode
EMIF10-COM01F2	FE	Flip Chip	8.3 mg	5000	Tape and reel

Note:

More information is available in the application notes:

AN1235: "Flip Chip: Package description and recommendations for use"

AN1751: "EMI Filters: Recommendations and measurements"

## 6 Revision history

Table 4. Document revision history

Date	Revision	Description of changes
14-Dec-2004	1	First issue.
08-Apr-2005	2	Die shrink.
19-Oct-2005	3	Replaced Figures 3 and 13. Added ECOPACK statement.
03-Apr-2006	4	Reformatted to current standard. Pin identification in Figure 1 updated.
17-Apr-2008	5	Updated ECOPACK statement. Updated <a href="#">Figure 10</a> , <a href="#">Figure 11</a> and <a href="#">Figure 14</a> . Reformatted to current standards.

**Please Read Carefully:**

Information in this document is provided solely in connection with ST products. STMicroelectronics NV and its subsidiaries ("ST") reserve the right to make changes, corrections, modifications or improvements, to this document, and the products and services described herein at any time, without notice.

All ST products are sold pursuant to ST's terms and conditions of sale.

Purchasers are solely responsible for the choice, selection and use of the ST products and services described herein, and ST assumes no liability whatsoever relating to the choice, selection or use of the ST products and services described herein.

No license, express or implied, by estoppel or otherwise, to any intellectual property rights is granted under this document. If any part of this document refers to any third party products or services it shall not be deemed a license grant by ST for the use of such third party products or services, or any intellectual property contained therein or considered as a warranty covering the use in any manner whatsoever of such third party products or services or any intellectual property contained therein.

**UNLESS OTHERWISE SET FORTH IN ST'S TERMS AND CONDITIONS OF SALE ST DISCLAIMS ANY EXPRESS OR IMPLIED WARRANTY WITH RESPECT TO THE USE AND/OR SALE OF ST PRODUCTS INCLUDING WITHOUT LIMITATION IMPLIED WARRANTIES OF MERCHANTABILITY, FITNESS FOR A PARTICULAR PURPOSE (AND THEIR EQUIVALENTS UNDER THE LAWS OF ANY JURISDICTION), OR INFRINGEMENT OF ANY PATENT, COPYRIGHT OR OTHER INTELLECTUAL PROPERTY RIGHT.**

**UNLESS EXPRESSLY APPROVED IN WRITING BY AN AUTHORIZED REPRESENTATIVE OF ST, ST PRODUCTS ARE NOT DESIGNED, AUTHORIZED OR WARRANTED FOR USE IN MILITARY, AIR CRAFT, SPACE, LIFE SAVING, OR LIFE SUSTAINING APPLICATIONS, NOR IN PRODUCTS OR SYSTEMS, WHERE FAILURE OR MALFUNCTION MAY RESULT IN PERSONAL INJURY, DEATH, OR SEVERE PROPERTY OR ENVIRONMENTAL DAMAGE.**

Resale of ST products with provisions different from the statements and/or technical features set forth in this document shall immediately void any warranty granted by ST for the ST product or service described herein and shall not create or extend in any manner whatsoever, any liability of ST.

ST and the ST logo are trademarks or registered trademarks of ST in various countries.

Information in this document supersedes and replaces all information previously supplied.

The ST logo is a registered trademark of STMicroelectronics. All other names are the property of their respective owners.

© 2008 STMicroelectronics - All rights reserved

STMicroelectronics group of companies

Australia - Belgium - Brazil - Canada - China - Czech Republic - Finland - France - Germany - Hong Kong - India - Israel - Italy - Japan - Malaysia - Malta - Morocco - Singapore - Spain - Sweden - Switzerland - United Kingdom - United States of America

[www.st.com](http://www.st.com)