



MFP version of EM6621 Ultra Low Power Microcontroller with 4x20 LCD Driver

Features

- Low Power
 - 11 μ A active mode, LCD On
 - 1.8 μ A standby mode, LCD Off
 - 0.1 μ A sleep mode @ 3 V, 32 KHz, 25 °C
- Large Voltage range, 2 to 5.5 V
- 2 clocks per instruction cycle
- 72 basic instructions
- EEPROM 4096 x 16 bits
- RAM 128 x 4 bits
- Max. 12 inputs ; port A, port B, port SP
- Max. 8 outputs ; port B, port SP
- Voltage Level Detector, 8 levels software selectable from 1.2 V up to 4.0 V
- Melody, 7 tones + silence inclusive 4-bit timer
- Universal 10-bit counter, PWM, event counter
- Prescaler down to 1 second (crystal = 32 KHz)
- 1/1000 sec 12 bit binary coded decimal counter with hard or software start/stop function
- LCD 20 Segments, 3 or 4 times multiplexed
- 3 wire serial port , 8 bit, master and slave mode
- 5 external interrupts (port A, serial interface)
- 8 internal interrupts (3x prescaler, BCD counter 2x10-bit counter, melody timer, serial interface)
- timer watchdog and oscillation supervisor

Figure 1. Architecture

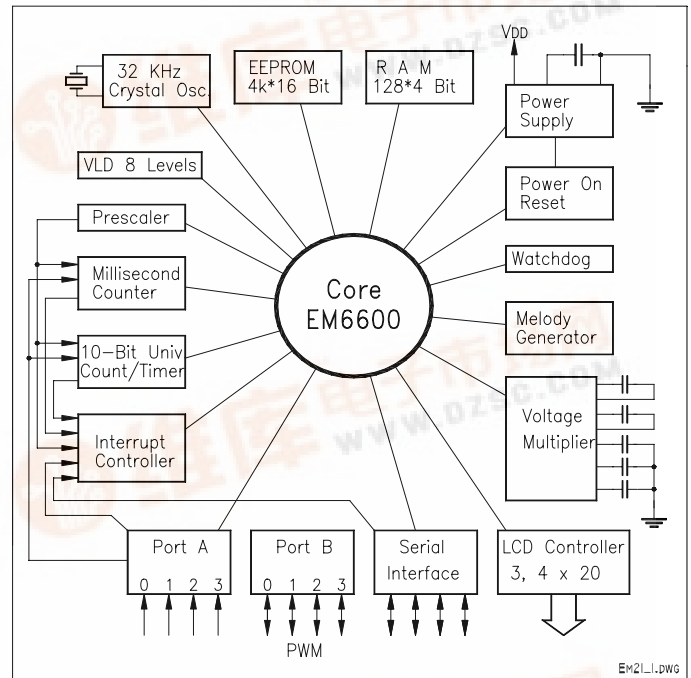

Description

The EM6521 is an advanced single chip CMOS 4-bit microcontroller. It contains EEPROM, RAM, LCD driver, power on reset, watchdog timer, oscillation detection circuit, 10-bit up/down and event counter, 1ms BCD counter, prescaler, voltage level detector (Vld), serial interface and several clock functions. The low voltage feature and low power consumption make it the most suitable controller for battery, stand alone and mobile equipment. The EM6521 is manufactured using EM Marin's Advanced Low Power (ALP) CMOS Process.

Typical Applications

- Timing device
- Automotive controls with display
- Intelligent display driver
- Measurement equipment
- Domestic appliance
- Interactive system with display
- Timer / sports timing devices
- Bicycle computers
- Safety and security devices

Figure 2. Pin Configuration, TQFP52 10 * 10 * 1 mm

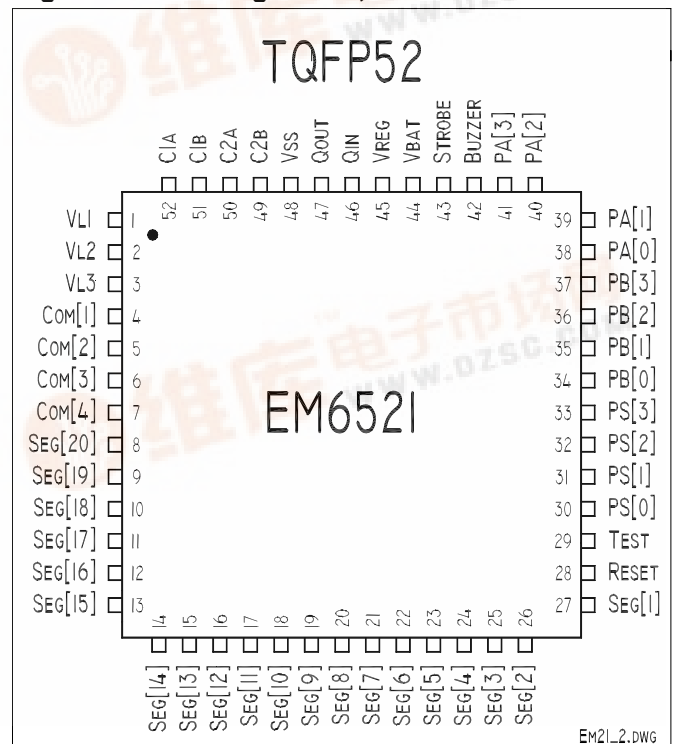

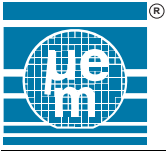

EM6521 at a glance

• Power Supply

- Low voltage low power architecture including internal voltage regulator
- 2.0 ... 5.5 V battery voltage
- 11 μ A in active mode (Xtal, LCD on, 25 °C)
- 1.8 μ A in standby mode (Xtal, LCD off, 25 °C)
- 0.1 μ A in sleep mode (25 °C)
- 32 KHz Oscillator

• RAM

- 64 x 4 bit, direct addressable
- 64 x 4 bit, indexed addressable

• EEPROM

- 4096 x 16 bit, metal mask programmable

• CPU

- 4-bit RISC architecture
- 2 clock cycles per instruction
- 72 basic instructions

• Main Operating Modes and Resets

- Active mode (CPU is running)
- Standby mode (CPU in halt)
- Sleep mode (no clock, reset state)
- Watchdog reset (logic and oscillation watchdogs)
- Reset terminal and POR
- Reset with input combination on port A (register selectable)

• Liquid Crystal Display Driver (LCD)

- 20 Segments 3 or 4 times multiplexed
- Internal or external voltage multiplier
- Free Segment allocation architecture
- LCD switch off for power save

• 8-Bit Serial Interface

- 3 wire master/slave mode
- READY output during data transfer
- Maximum shift clock is equal to system clock
- Interrupt request to the CPU after 8 bits
- Supports different serial formats
- Can be configured as a parallel 4 bit I/O port
- Direct input read on the port terminals
- All outputs can be put tristate (default)
- Selectable pull resistors in input mode
- CMOS or Nch. open drain outputs

• Millisecond Counter

- 3 digits binary coded decimal counter (12 bits)
- PA[3] input pulse width and period measurement
- Internal 1000 Hz clock generation
- Hardware or software controlled start stop mode
- Interrupt request on either 1/10 Sec or 1Sec

• 4-Bit Input Port A

- Direct input read on the port terminals
- Debouncer function available on all inputs
- Interrupt request on positive or negative edge
- Pull resistor selectable by register
- Test variables (software) for conditional jumps
- PA[0] and PA[3] are inputs for the event counter
- PA[3] is Start/Stop input for the millisecond counter
- Reset with input combination

• 4-Bit Bi-directional Port B

- All different functions bit-wise selectable
- Direct input read on the port terminals
- Data output latches
- CMOS or Nch. open drain outputs
- Pull-down or pull-up selectable
- Selectable PWM, 32kHz, 1kHz and 1Hz output

• Prescaler

- 15 stage system clock divider down to 1Hz
- 3 Interrupt requests; 1Hz, 32Hz or 8Hz, Blink
- Prescaler reset (4kHz to 1Hz)

• Voltage Level Detector (SVLD)

- 8 different levels from 1.2 V to 4.0 V (ROM Version)
- Busy flag during measure

• 10-Bit Universal Counter

- 10, 8, 6 or 4 bit up/down counting
- Parallel load
- Event counting (PA[0] or PA[3])
- 8 different input clocks
- Full 10 bit or limited (8, 6, 4 bit) compare function
- 2 interrupt requests (on compare and on 0)
- Hi-frequency input on PA[3] and PA[0]
- Pulse width modulation (PWM) output

• Melody Generator

- Dedicated Buzzer terminal
- 7 tones plus silence output
- The output can be put tristate (default)
- Internal 4-bit timer, usable also in standalone mode
- 4 different timer input clocks
- Timer with automatic reload or single run
- Timer interrupt request when reaching 0

• Interrupt Controller

- 5 external and 8 internal interrupt request sources
- Each interrupt request can individually be masked
- Each interrupt flag can individually be reset
- Automatic reset of each interrupt request after read
- General interrupt request to CPU can be disabled
- Automatic enabling of general interrupt request flag when going into HALT mode

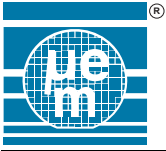
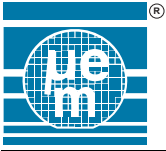

Table of Contents

Features	1	8.5.2 PWM Characteristics	35
Description	1	8.6 Counter Setup	36
Typical Applications	1	8.7 10-bit Counter Registers	36
EM6521 at a glance	2	9 Millisecond Counter	38
1 Pin Description for EM6521	4	9.1 PA[3] Input for MSC	38
1.1 Programming Connections	6	9.2 IRQ from MSC	38
2 Operating Modes	7	9.3 MSC-Modes	39
2.1 Active Mode	7	9.4 Mode selection	39
2.2 Standby Mode	7	9.5 Millisecond Counter Registers	41
2.3 Sleep Mode	7	10 Interrupt Controller	42
3 Power Supply	8	10.1 Interrupt Control Registers	43
4 Reset	9	11 Supply Voltage Level Detector	44
4.1 Oscillation Detection Circuit	10	11.1 SVLD Register	44
4.2 Reset Terminal	10	12 Strobe Output	45
4.3 Input Port A Reset Function	10	12.1 Strobe Register	45
4.4 Digital Watchdog Timer Reset	11	13 RAM	46
4.5 CPU State after Reset	11	14 LCD Driver	47
5 Oscillator and Prescaler	12	14.1 LCD Control	48
5.1 Oscillator	12	14.2 LCD Addressing	48
5.2 Prescaler	12	14.3 Free Segment Allocation	49
6 Input and Output Ports	14	14.4 LCD Registers	49
6.1 Ports Overview	14	15 Peripheral Memory Map	51
6.2 Port A	15	16 Option Register Memory Map	55
6.2.1 IRQ on Port A	15	17 Active Supply Current Test	56
6.2.2 Pull-up or Pull-down	16	18 Mask Options	57
6.2.3 Software Test Variables	16	18.1 Input / Output Ports	57
6.2.4 Port A for 10-Bit Counter and MSC	16	18.1.1 Port A Metal Options	57
6.3 Port A Registers	16	18.1.2 Port B Metal Options	58
6.4 Port B	18	18.1.3 Port SP Metal Options	59
6.4.1 Input / Output Mode	18	18.1.4 Voltage Regulator Option	59
6.4.2 Pull-up or Pull-down	19	18.1.5 Debouncer Frequency Option	60
6.4.3 CMOS / NCH. Open Drain Output	19	18.1.6 User defined LCD Segment Allocation	60
6.4.4 PWM and Frequency Output	20	19 Measured Electrical Behaviors	61
6.5 Port B Registers	20	19.1 IDD Current	61
6.6 Port Serial	21	19.2 Regulator Voltage	61
6.6.1 4-bit Parallel I/O	21	19.3 Pull Resistors	61
6.6.2 Pull-up or Pull-down	22	19.4 Output currents	62
6.6.3 Nch. Open Drain Outputs	23	20 EM6521 Electrical Specification	63
6.6.4 General Functional Description	23	20.1 Absolute Maximum Ratings	63
6.6.5 Detailed Functional Description	24	20.2 Handling Procedures	63
6.6.6 Output Modes	24	20.3 Standard Operating Conditions	63
6.6.7 Reset and Sleep on Port SP	25	20.4 DC Characteristics - Power Supply	63
6.7 Serial Interface Registers	26	20.5 Supply Voltage Level Detector	64
7 Melody, Buzzer	28	20.6 Oscillator	64
7.1 4-Bit Timer	28	20.7 DC characteristics - I/O Pins	65
7.1.1 Single Run Mode	29	20.8 LCD SEG[20:1] Outputs	66
7.1.2 Continuous Run Mode	29	20.9 LCD Com[4:1] Outputs	66
7.2 Programming Order	30	20.10 DC Output Component	66
7.3 Melody Registers	30	20.11 LCD Voltage Multiplier	66
8 10-bit Counter	32	21 Pad Location Diagram	67
8.1 Full and Limited Bit Counting	32	22 Package & Ordering information	68
8.2 Frequency Select and Up/Down Counting	33	22.1 Ordering Information	68
8.3 Event Counting	34		
8.4 Compare Function	34		
8.5 Pulse Width Modulation (PWM)	34		
8.5.1 How the PWM Generator works.	35		



EM6521

1 Pin Description for EM6521

Chip	TQFP 52	DIL 64	Signal Name	Function	Remarks
1	1	10	VL1	Voltage multiplier level 1	LCD level 1 input, if external supply selected
2	2	11	VL2	Voltage multiplier level 2	LCD level 2 input, if external supply selected
3	3	12	VL3	Voltage multiplier level 3	LCD level 3 input, if external supply selected
4	4	13	COM[1]	LCD back plane 1	
5	5	14	COM[2]	LCD back plane 2	
6	6	15	COM[3]	LCD back plane 3	
7	7	16	COM[4]	LCD back plane 4	Not used if 3 times multiplexed
8	8	18	SEG[20]	LCD Segment 20	
9	9	19	SEG[19]	LCD Segment 19	
10	10	20	SEG[18]	LCD Segment 18	
11	11	21	SEG[17]	LCD Segment 17	
12	12	22	SEG[16]	LCD Segment 16	
13	13	23	SEG[15]	LCD Segment 15	
14	14	26	SEG[14]	LCD Segment 14	
15	15	27	SEG[13]	LCD Segment 13	
16	16	28	SEG[12]	LCD Segment 12	
17	17	29	SEG[11]	LCD Segment 11	
18	18	30	SEG[10]	LCD Segment 10	
19	19	31	SEG[9]	LCD Segment 9	
20	20	33	SEG[8]	LCD Segment 8	
21	21	34	SEG[7]	LCD Segment 7	
22	22	35	SEG[6]	LCD Segment 6	
23	23	36	SEG[5]	LCD Segment 5	
24	24	37	SEG[4]	LCD Segment 4	
25	25	38	SEG[3]	LCD Segment 3	
26	26	39	SEG[2]	LCD Segment 2	
27	27	42	SEG[1]	LCD Segment 1	
28	28	43	Reset	Input reset terminal, internal pull-down 15 KOhm	Main reset
29	29	44	Test	Input test terminal, internal pull-down 15 KOhm	For EM tests only, ground 0 ! Except when needed for MFP programming
30	30	45	PSP[0]	Input/output , open drain serial port : SIN parallel out terminal 0	Serial interface data in or parallel data[0] in/out
31	31	46	PSP[1]	Output , open drain serial port : Ready/CS parallel out terminal 1	Serial interface Ready CS or parallel data[1] in/out
32	32	47	PSP[2]	Output , open drain serial port : SOUT parallel out terminal 2	Serial interface data out or parallel data[2] in/out
33	33	49	PSP[3]	Input/output , open drain serial port : SCLK parallel out terminal 3	Serial interface clock I/O or parallel data[3] in/out
34	34	50	PB[0]	Input/output, open drain port B terminal 0	Port B data[0] I/O or Ck[1] output



EM6521

Chip	TQFP 52	DIL 64	Signal Name	Function	Remarks
35	35	51	PB[1]	Input/output, open drain port B terminal 1	Port B data[1] I/O or Ck[11] output
36	36	52	PB[2]	Input/output, open drain port B terminal 2	Port B data[2] I/O or Ck[16] output
37	37	53	PB[3]	Input/output, open drain port B terminal 3	Port B data[3] I/O or PWM output
38	38	54	PA[0]	Input port A terminal 0	TestVar 1 Event counter
39	39	55	PA[1]	Input port A terminal 1	TestVar 2
40	40	58	PA[2]	Input port A terminal 2	TestVar 3
41	41	59	PA[3]	Input port A terminal 3	Event counter, MSC start/stop control
42	42	60	Buzzer	Output Buzzer terminal	
43	43	61	Strobe	Output Strobe terminal	μ P reset state or/and port B write or sleep flag out
44	44	62	$V_{BAT} = V_{DD}$	Positive power supply	MFP Connection
45	45	63	V_{reg}	Internal voltage regulator	Connect to minimum 100nF, MFP connection
46	46	64	Qin/Osc1	Crystal terminal 1	32 KHz crystal, MFP connection
47	47	2	Qout /Osc2	Crystal terminal 2	32 KHz crystal, MFP connection
48	48	3	V_{SS}	Negative power supply	ref. terminal, MFP connection
49	49	4	C2B	Voltage multiplier	Not needed if ext. supply
50	50	5	C2A	Voltage multiplier	Not needed if ext. supply
51	51	6	C1B	Voltage multiplier	Not needed if ext. supply
52	52	7	C1A	Voltage multiplier	Not needed if ext. supply

Gray shaded areas : Terminals needed for MFP programming connections (V_{DD} , V_{reg} , Qin, Qout, Test). See also Programming connections.

EM Microelectronic-Marlin SA cannot assume responsibility for use of any circuitry described other than circuitry entirely embodied in an EM Microelectronic-Marlin SA product. EM Microelectronic-Marlin SA reserves the right to change the circuitry and specifications without notice at any time. You are strongly urged to ensure that the information given has not been superseded by a more up-to-date version.

Figure 3. Typical Configuration

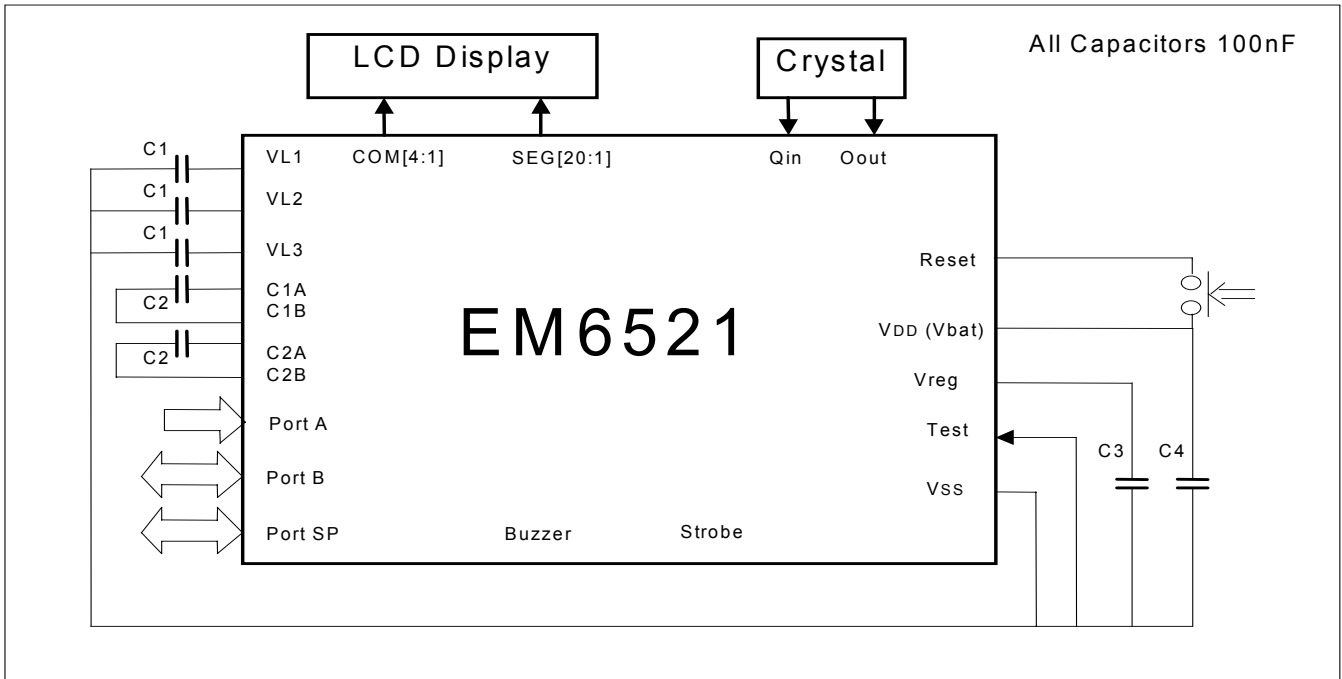

1.1 Programming Connections

The EM6521 can be programmed using the standard EM MFP programming box for 4 bit uControllers. The interface signals are listed in the table below. The circuit can be programmed on the programming box or directly on the PCB. For more information please refer to the MFP programmer's manual.

Chip	TQFP	DIL	Signal Name	Function	Remarks
29	29	44	Test	Input test terminal Internal pull-down 15k	Usually 1 in MFP mode, 0 resets the MFP interface
44	44	62	$V_{BAT} = V_{DD}$	Positive power supply	MFP Power Connection
45	45	63	V_{reg}	Internal voltage regulator	MFP power Connection, adapts the Oscillator voltage to V_{BAT}
46	46	64	Qin/Osc1	Crystal terminal	MFP Serial Data Input / Output
47	47	2	Qout /Osc2	Crystal terminal	MFP serial Clock Input
48	48	3	V_{SS}	Negative power supply	MFP Connection, Reference terminal

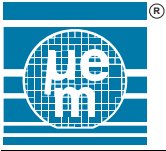

2 Operating Modes

The EM6521 has two low power dissipation modes, standby and sleep. Figure 4 is a transition diagram for these modes.

2.1 Active Mode

The active mode is the actual CPU running mode. Instructions are read from the internal ROM and executed by the CPU. Leaving active mode via the halt instruction to go into standby mode, the **Sleep** bit write to go into Sleep mode or a reset from port A to go into reset mode.

2.2 Standby Mode

Executing a halt instruction puts the EM6521 into standby mode. The voltage regulator, oscillator, watchdog timer, LCD, interrupts, timers and counters are operating. However, the CPU stops since the clock related to instruction execution stops. Registers, RAM and I/O pins retain their states prior to standby mode. Standby is canceled by a reset or an interrupt request if enabled.

2.3 Sleep Mode

Writing to the **Sleep** bit in the **RegSysCntl1** register puts the EM6521 in sleep mode. The oscillator stops and most functions of the EM6521 are inactive. To be able to write to the **Sleep** bit, the **SleepEn** bit in **RegSysCntl2** must first be set to "1". In sleep mode only the voltage regulator and the reset input are active. The RAM data integrity is maintained. Sleep mode may be canceled only by a high level of min 10µs at the EM6521 Reset terminal or by the selected port A input reset combination, if option **InpResSleep** is turned on.

Due to the cold-start characteristics of the oscillator, waking up from sleep mode may take some time to guarantee stable oscillation. During sleep mode and the following start up the EM6521 is in reset state. Waking up from sleep clears the **Sleep** flag but not the **SleepEn** bit. Inspecting the **SleepEn** allows to determine if the EM6521 was powered up (**SleepEn** = "0") or woken up from sleep (**SleepEn** = "1").

Figure 4 Mode transition diagram

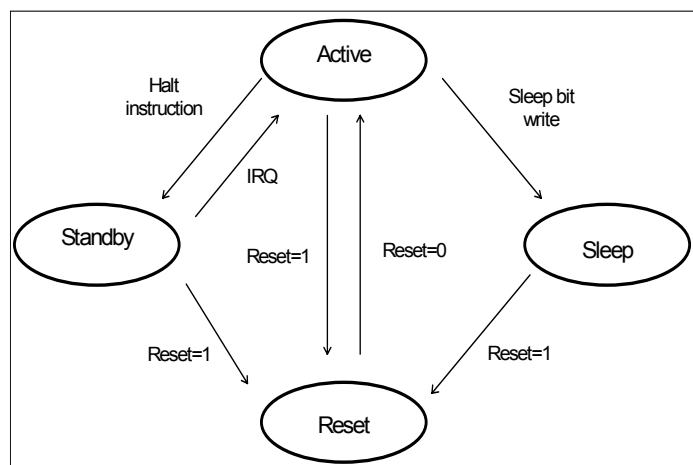

Table 2.3.1. Internal State in Standby and Sleep Mode

Function	Standby	Sleep
Oscillator	Active	Stopped
Oscillator Watchdog	Active	Stopped
Instruction Execution	Stopped	Stopped
Interrupt Functions	Active	Stopped
Registers and Flags	Retained	Reset
RAM Data	Retained	Retained
Option Registers	Retained	Retained
Timer & Counter	Active	Reset
Logic Watchdog	Active	Reset
I/O Port B and Serial Port	Active	High Impedance, Pull's as defined in option register
Input Port A	Active	No pull resistors and inputs deactivated except if InpResSleep = "1"
LCD	Active	Stopped (display off)
Strobe Output	Active	Active
Buzzer Output	Active	High Impedance
Voltage Level Detector	Finishes ongoing measure, then stop	Stopped
Reset Pin	Active	Active

3 Power Supply

The EM6521 is supplied by a single external power supply between V_{DD} (V_{BAT}) and V_{SS} (Ground). A built-in voltage regulator generates V_{reg} providing regulated voltage for the oscillator and the internal logic. The output drivers are supplied directly from the external supply V_{DD} . The internal power configuration is shown below in Figure 5.

Figure 5. Internal Power Supply

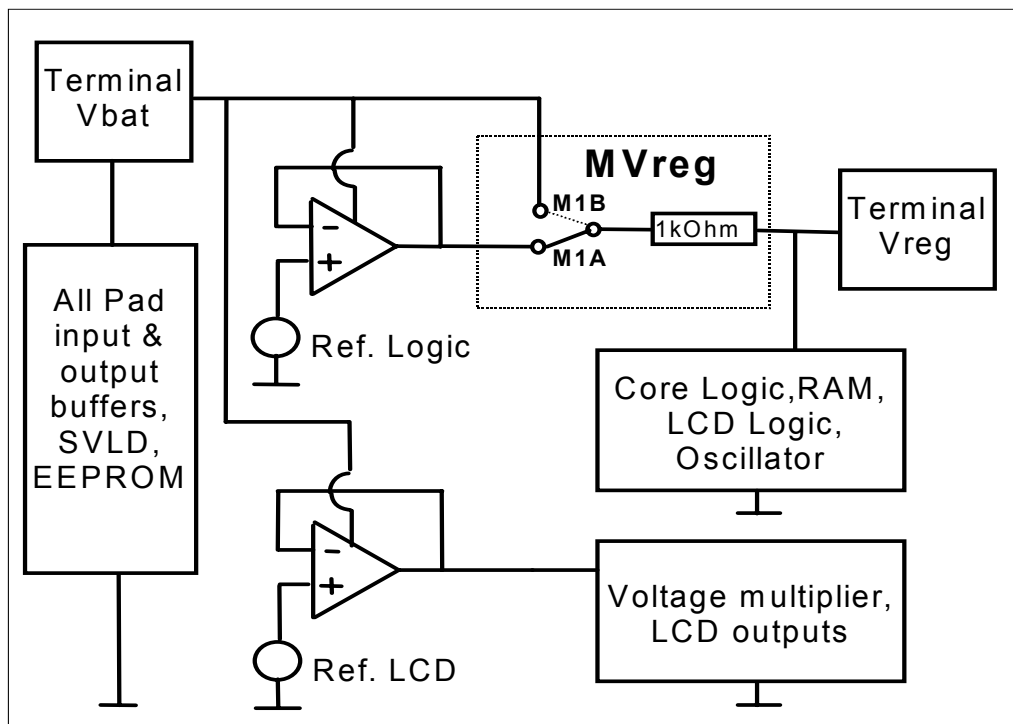

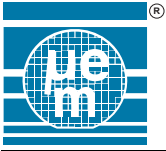

4 Reset

Figure 6. illustrates the reset structure of the EM6521. One can see that there are six possible reset sources :

- (1) Internal initial reset from the Power On Reset (POR) circuitry. --> POR
- (2) External reset from the Reset terminal. --> System Reset, Reset CPU
- (3) External reset by simultaneous high/low inputs to port A. --> System Reset, Reset CPU
(Combinations are defined in the registers **OptInpRSel1** and **OptInpRSel2**)
- (4) Internal reset from the Digital Watchdog. --> System Reset, Reset CPU
- (5) Internal reset from the Oscillation Detection Circuit. --> System Reset, Reset CPU
- (6) Internal reset when sleep mode is activated. --> System Reset, Reset CPU

Reset CPU

All reset sources activate the System Reset and the Reset CPU. The 'System Reset Delay' ensures that the system reset remains active long enough for all system functions to be reset (active for n system clock cycles). The 'CPU Reset Delay' ensures that the reset CPU remains active until the oscillator is in stable oscillation.

As well as activating the system reset and the reset CPU, the POR also resets all option registers and the sleep enable (**SleepEn**) latch. System reset and reset CPU do not reset the option registers nor the **SleepEn** latch.

Reset state can be shown on Strobe terminal by selecting **StrobeOutSel1,0 = 0** in **RegLcdCntl1**.

Figure 6. Reset Structure

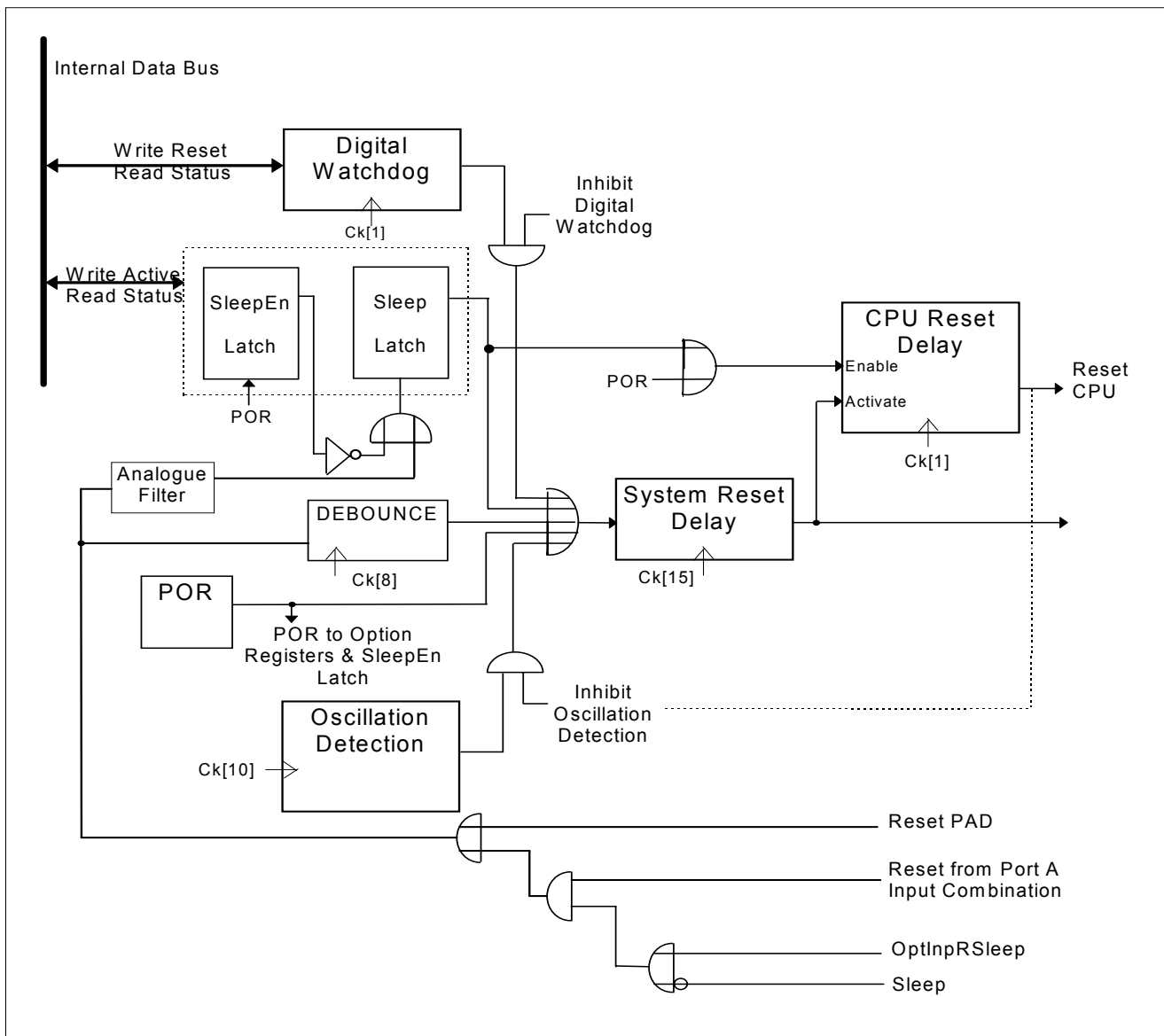



4.1 Oscillation Detection Circuit

At power on, the voltage regulator starts to follow the supply voltage and triggers the power on reset circuitry, and thus the system reset. The CPU of the EM6521 remains in the reset state for the 'CPU Reset Delay', to allow the oscillator to stabilize after power up.

The oscillator is disabled during sleep mode. So when waking up from sleep mode, the CPU of the EM6521 remains in the reset state for the CPU Reset Delay, to allow the oscillator to stabilize. During this time, the Oscillation Detection Circuit is inhibited.

In active or standby modes, the oscillator detection circuit monitors the oscillator. If it stops for any reason, a system reset is generated. After clock restart the CPU waits for the CPU Reset Delay before executing the first instructions.

The oscillation detection circuitry can be inhibited with bit **NoOscWD** = 1 in register **RegVldCntl**. At power up, and after any system reset, the function is activated.

The 'CPU Reset Delay' is 32768 system clocks (Ck[16]) long.

4.2 Reset Terminal

During active or standby modes the Reset terminal has a debouncer to reject noise. Reset must therefore be active for at least 16 ms (system clock = 32 KHz).

When canceling sleep mode, the debouncer is not active (no clock), however, reset passes through an analogue filter with a time constant of typical. 5µs. In this case Reset pin must be high for at least 10 µs to generate a system reset.

4.3 Input Port A Reset Function

By writing the **OptInpRsel1** and **OptInpRsel2** registers it is possible to choose any combination of port A input values to execute a system reset. The reset condition must be valid for at least 16ms (system clock = 32kHz) in active and standby mode.

OPTInpRSleep selects the input port A reset function in sleep mode. If set to "1" the occurrence of the selected combination for input port A reset will immediately trigger a system reset (no debouncer) .

Reset combination selection (*InpReset*) is done with registers **OptInpRsel1** and **OptInpRsel2**. Following formula is applicable :

$$\text{InpResPA} = \text{InpResPA}[0] \cdot \text{InpResPA}[1] \cdot \text{InpResPA}[2] \cdot \text{InpResPA}[3]$$

InpRes1PA[n]	InpRes2PA[n]	InpResPA[n]
0	0	V _{SS}
0	1	PA[n]
1	0	not PA[n]
1	1	V _{DD}

n = 0 to 3

i.e. ; - no reset if InpResPA[n] = V_{SS}.

- Don't care function on a single bit with its InpResPA[n] = V_{DD}.
- Always Reset if InpResPA[3:0] = 'b1111

Figure 7. Input Port A Reset Structure

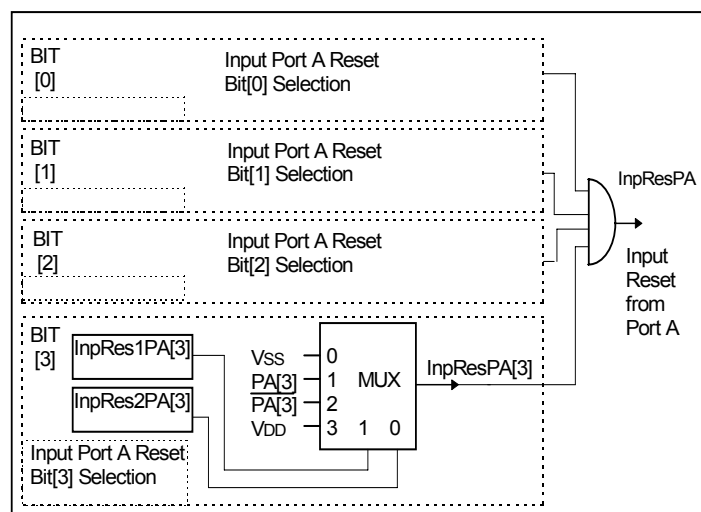

4.4 Digital Watchdog Timer Reset

The digital watchdog is a simple, non-programmable, 2-bit timer, that counts on each rising edge of Ck[1]. It will generate a system reset if it is not periodically cleared. The watchdog timer function can be inhibited by activating an inhibit digital watchdog bit (**NoLogicWD**) located in **RegVidCntl**. At power up, and after any system reset, the watchdog timer is activated.

If for any reason the CPU stops, then the watchdog timer can detect this situation and activate the system reset signal. This function can be used to detect program overrun, endless loops, etc. For normal operation, the watchdog timer must be reset periodically by software at least every 2.5 seconds (system clock = 32 KHz), or a system reset signal is generated.

The watchdog timer is reset by writing a '1' to the **WDRReset** bit in the timer. This resets the timer to zero and timer operation restarts immediately. When a '0' is written to **WDRReset** there is no effect. The watchdog timer operates also in the standby mode and thus, to avoid a system reset, one should not remain in standby mode for more than 2.5 seconds.

From a system reset state, the watchdog timer will become active after 3.5 seconds. However, if the watchdog timer is influenced from other sources (i.e. prescaler reset), then it could become active after just 2.5 seconds. It is therefore recommended to use the Prescaler **IRQHz1** interrupt to periodically reset the watchdog every second.

It is possible to read the current status of the watchdog timer in **RegSysCntl2**. After watchdog reset, the counting sequence is (on each rising edge of CK[1]) : '00', '01', '10', '11' {**WDVal1 WDVal0**}. When going into the '11' state, the watchdog reset will be active within ½ second. The watchdog reset activates the system reset which in turn resets the watchdog. If the watchdog is inhibited it's timer is reset and therefore always reads '0'.

Table 4.4.1 Watchdog Timer Register RegSysCntl2

Bit	Name	Reset	R/W	Description
3	WDRReset	0	R/W	Reset the Watchdog 1 -> Resets the Logic Watchdog 0 -> No action The Read value is always '0'
2	<i>SleepEn</i>	0	R/W	<i>See Operating modes (sleep)</i>
1	WDVal1	0	R	Watchdog timer data Ck[1] divided by 4
0	WDVal0	0	R	Watchdog timer data Ck[1] divided by 2

4.5 CPU State after Reset

Reset initializes the CPU as shown in Table 4.5.1 below.

Table 4.5.1 Initial CPU Value after Reset.

Name	Bits	Symbol	Initial Value
Program counter 0	12	PC0	hex 000 (as a result of Jump 0)
Program counter 1	12	PC1	Undefined
Program counter 2	12	PC2	Undefined
Stack pointer	2	SP	PSP[0] selected
Index register	7	IX	Undefined
Carry flag	1	CY	Undefined
Zero flag	1	Z	Undefined
Halt	1	HALT	0
Instruction register	16	IR	Jump 0
Periphery registers	4	Reg.	See peripheral memory map

5 Oscillator and Prescaler

5.1 Oscillator

A built-in crystal oscillator generates the system operating clock for the CPU and peripheral blocks, from an externally connected crystal (typically 32.768kHz). The oscillator circuit is supplied by the regulated voltage, V_{reg} . In sleep mode the oscillator is stopped.

EM's special design techniques guarantee the low current consumption of this oscillator. The external impedance between the oscillator pads must be greater than 10M Ω . Connection of any other components to the two oscillator pads must be confirmed by EM Microelectronic-Marin SA.

5.2 Prescaler

The prescaler consists of fifteen elements divider chain which delivers clock signals for the peripheral circuits such as timer/counter, buzzer, LCD voltage multiplier, debouncer and edge detectors, as well as generating prescaler interrupts. The input to the prescaler is the system clock signal. Power on initializes the prescaler to Hex(0001).

Table 5.2.1 Prescaler Clock Name Definition

Function	Name	32 KHz Xtal
System clock	Ck[16]	32768 Hz
System clock / 2	Ck[15]	16384 Hz
System clock / 4	Ck[14]	8192 Hz
System clock / 8	Ck[13]	4096 Hz
System clock / 16	Ck[12]	2048 Hz
System clock / 32	Ck[11]	1024 Hz
System clock / 64	Ck[10]	512 Hz
System clock / 128	ck [9]	256 Hz

Function	Name	32 KHz Xtal
System clock / 256	Ck[8]	128 Hz
System clock / 512	Ck[7]	64 Hz
System clock / 1024	Ck[6]	32 Hz
System clock / 2048	Ck[5]	16 Hz
System clock / 4096	Ck[4]	8 Hz
System clock / 8192	Ck[3]	4 Hz
System clock / 16384	Ck[2]	2 Hz
System clock / 32768	Ck[1]	1 Hz

Table 5.2.2 Control of Prescaler Register RegPresc

Bit	Name	Reset	R/W	Description
3	PWMon	0	R/W	see 10 bit counter
2	ResPresc	0	R/W	Write Reset prescaler 1 -> Resets the divider chain from Ck[14] down to Ck[2], sets Ck[1]. 0 -> No action. The Read value is always '0'
1	PrIntSel	0	R/W	Interrupt select. 0 -> Interrupt from Ck[4] 1 -> Interrupt from Ck[6]
0	DebSel	0	R/W	Debouncer clock select. 0 -> Debouncer with Ck[8] 1 -> Debouncer with Ck[11] or Ck[14], see below

Figure 8. Prescaler Frequency Timing

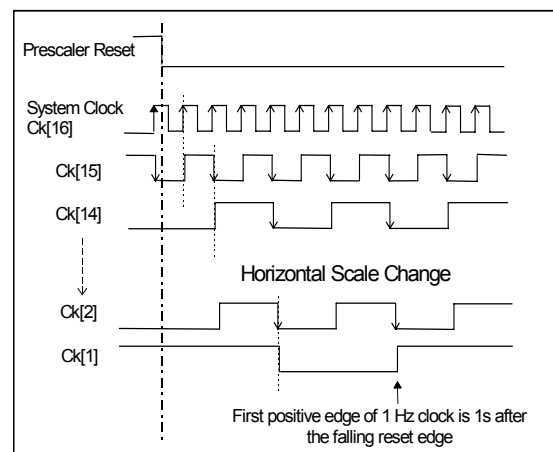

With DebSel = 1 one may choose either the Ck[11] or Ck[14] debouncer frequency by selecting the corresponding metal mask option (for ROM version only). Relative to 32kHz the corresponding max. debouncer times are then 2 ms or 0.25 ms. For the metal mask selection refer to chapter 18.1.5.

Switching the **PrintSel** may generate an interrupt request. Avoid it with **MaskIRQ32/8** = 0 selection during the switching operation.

The prescaler contains 3 interrupt sources:

- IRQ32/8 ; this is Ck[6] or Ck[4] positive edge interrupt, the selection is depending on bit **PrintSel**.
- IRQHz1 ; this is Ck[1] positive edge interrupt
- IRQBlink ; this is 3/4 of Ck[1] period interrupt

There is no interrupt generation on reset.

The first IRQHz1 Interrupt occurs 1 sec (32kHz) after reset.

A possible application for the IRQBlink is LCD-Display blinking control together with IRQHz1.

Figure 9. Prescaler Interrupts

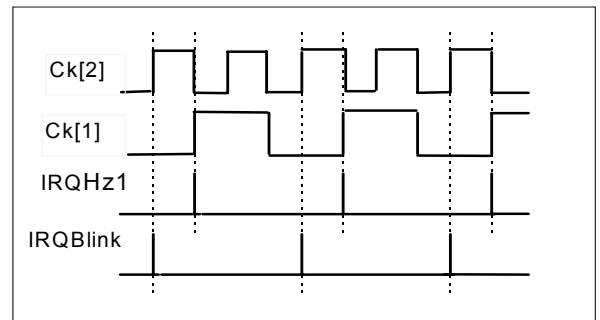

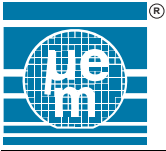

6 Input and Output Ports

The EM6521 has:

- One 4-bit input port (port A)
- One 4-bit input/output port. (port B)
- One serial interface (port SP) also configurable as 4-bit I/O port

Pull resistors can be added to all this ports with metal (ROM version only) and/or register options.

6.1 Ports Overview

Table 6.1.1 Input and Output Ports Overview

Port	Mode	Mask(M:) or Register(R:) Option	Function	Bit-wise Multifunction on Ports			
				PA[3]	PA[2]	PA[1]	PA[0]
PA [3:0]	Input	M: Pull-up M: Pull-down (default) R: Pull(up/down) select R: Debouncer or direct input for IRQ requests and Counter R: + or - for IRQ-edge and counter R: Input reset combination	-Input -Bit-wise interrupt request -Software test variable conditional jump -PA[3],PA[0] input for the event counter -PA[3] input for the millisecond counter -Port A reset inputs	10 bit event counter clock start/stop of MSC	-	-	10 bit event counter clock -
PB [3:0]	Individual input or output	R: CMOS or Nch. open drain output R: Pull-down on input R: Pull-up on input	-Input or output -PB[3] for the PWM output -PB[2:0] for the Ck[16,11,1] output -Tristate output	PWM output	Ck[16] output	Ck[11] output	Ck[1] output
PS [3:0]	Serial I/O or port-wise input / output	R: CMOS or Nch open drain output R: Pull-down on input R: Pull-up on input	-PSP[3], serial clock out -PSP[2], serial data out -PSP[1], serial status out -PSP[0], serial data in -PSP[3:0] 4-bit input/output -Tristate output	Serial clock output SCLK	Serial data output SOUT	Ready or CS Ready/CS	Serial data input SIN

6.2 Port A

The EM6521 has one four bit general purpose CMOS input port. The port A input can be read at any time, internal pull-up or pull-down resistors can be chosen by metal mask (for ROM version only). All selections concerning port A are bit-wise executable. I.e. Pull-up on PA[2], pull-down on PA[0], positive IRQ edge on PA[0] but negative on PA[1], etc.

In sleep mode the port A pull-up or pull-down resistors are turned off, and the inputs are deactivated except if the **InpResSleep** bit in the option register **OPTFSeI** is set to 1. In this case the port A inputs are continuously monitored to match the input reset condition which will immediately wake the EM6521 from sleep mode (all pull resistors remain).

Figure 10. Input Port A Configuration

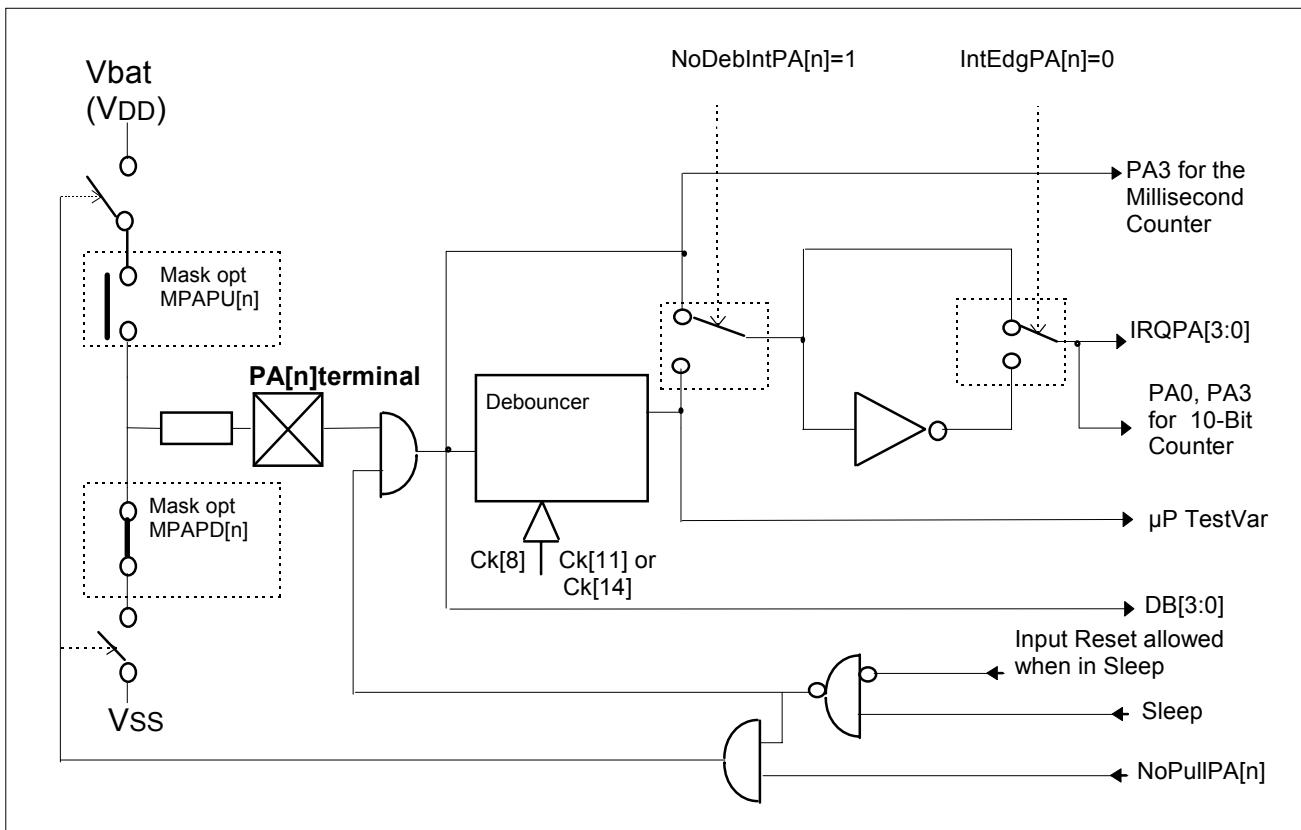

6.2.1 IRQ on Port A

For interrupt request generation (IRQ) one can choose direct or debouncer input and positive or negative edge IRQ triggering. With the debouncer selected (**OPTDebIntPA**) the input must be stable for two rising edges of the selected debouncer clock (**RegPresc**). This means a worst case of 16 ms (default) or 2 ms (0.25 ms by metal mask, for ROM Version only) with a system clock of 32 KHz.

Either a positive or a negative edge on the port A inputs - after debouncer or not - can generate an interrupt request. This selection is done in the option register **OPTIntEdgPA**.

All four bits of port A can provide an IRQ, each pin with its own interrupt mask bit in the **RegIRQMask1** register. When an IRQ occurs, inspection of the **RegIRQ1**, **RegIRQ2** and **RegIRQ3** registers allows the interrupt to be identified and treated.

At power on or after any reset the **RegIRQMask1** is set to 0, thus disabling any input interrupt. A new interrupt is only stored with the next active edge after the corresponding interrupt mask is cleared. See also the interrupt chapter 10.

It is recommended to mask the port A IRQ's while one changes the selected IRQ edge. Else one may generate a IRQ (Software IRQ). I.e. PA[0] on '0' then changing from positive to negative edge selection on PA[0] will immediately trigger an IRQPA[0] if the IRQ was not masked.

6.2.2 Pull-up or Pull-down

Each of the input port terminals PA[3:0] has a resistor integrated which can be used either as pull-up or pull-down resistor, depending on the selected metal mask options(ROM version only). See the port A metal mask chapter for details. The pull resistor can be inhibited using the **NoPullPA[n]** bits in the register **OptNoPullPA**.

Table 6.2.1. Pull-up or Pull-down Resistor on Port A Inputs

Option mask pull-up MPAPU[n]	Option mask pull-down MPAPD[n]	NoPullPA[n] value	Action	with n=0...3
no	no	x	no pull-up, no pull-down	
no	yes	0	no pull-up, pull-down	
no	yes	1	no pull-up, no pull-down	
yes	no	0	pull-up, no pull-down	
yes	no	1	no pull-up , no pull-down	
yes	yes	x	not allowed*	

* only pull-up or pull-down may be chosen on any port A terminal (one choice is excluding the other)

6.2.3 Software Test Variables

The port A terminals PA[2:0] are also used as input conditions for conditional software branches. Independent of the **OPTDebIntPA** and the **OPTIntEdgPA**. These CPU inputs always have a debouncer.

- Debounced PA[0] is connected to CPU TestVar1.
- Debounced PA[1] is connected to CPU TestVar2.
- Debounced PA[2] is connected to CPU TestVar3.

6.2.4 Port A for 10-Bit Counter and MSC

The PA[0] and PA[3] inputs can be used as the clock input terminal for the 10 bit counter in "event count" mode. As for the IRQ generation one can choose debouncer or direct input with the register **OPTDebIntPA** and non-inverted or inverted input with the register **OPTIntEdgPA**. Debouncer input is always recommended.

Pad input PA[3] is also used as start/stop control for the millisecond counter. This control signal is derived from PA[3], it is independent of the port A debouncer and edge selection. Refer also to Figure 10.

6.3 Port A Registers

Table 6.3.1 Register RegPA

Bit	Name	Reset	R/W	Description
3	PAData[3]	-	R*	PA[3] input status
2	PAData[2]	-	R*	PA[2] input status
1	PAData[1]	-	R*	PA[1] input status
0	PAData[0]	-	R*	PA[0] input status

* Direct read on port A terminals

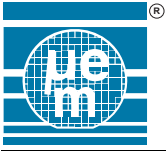

Table 6.3.2 Register RegIRQMask1

Bit	Name	Reset	R/W	Description
3	MaskIRQPA[3]	0	R/W	Interrupt mask for PA[3] input
2	MaskIRQPA[2]	0	R/W	Interrupt mask for PA[2] input
1	MaskIRQPA[1]	0	R/W	Interrupt mask for PA[1] input
0	MaskIRQPA[0]	0	R/W	Interrupt mask for PA[0] input

Default "0" is: interrupt request masked, no new request stored

Table 6.3.3 Register RegIRQ1

Bit	Name	Reset	R/W	Description
3	IRQPA[3]	0	R/W*	Interrupt request on PA[3]
2	IRQPA[2]	0	R/W*	Interrupt request on PA[2]
1	IRQPA[1]	0	R/W*	Interrupt request on PA[1]
0	IRQPA[0]	0	R/W*	Interrupt request on PA[0]

*; Write "1" clears the bit, write "0" has no action, default "0" is: no interrupt request

Table 6.3.4 Register OPTIntEdgPA

Bit	Name	power on value	R/W	Description
3	IntEdgPA[3]	0	R/W	Interrupt edge select for PA[3]
2	IntEdgPA[2]	0	R/W	Interrupt edge select for PA[2]
1	IntEdgPA[1]	0	R/W	Interrupt edge select for PA[1]
0	IntEdgPA[0]	0	R/W	Interrupt edge select for PA[0]

Default "0" is: Positive edge selection

Table 6.3.5 Register OPTDebIntPA

Bit	Name	power on value	R/W	Description
3	NoDebIntPA[3]	0	R/W	Interrupt debounced for PA[3]
2	NoDebIntPA[2]	0	R/W	Interrupt debounced for PA[2]
1	NoDebIntPA[1]	0	R/W	Interrupt debounced for PA[1]
0	NoDebIntPA[0]	0	R/W	Interrupt debounced for PA[0]

Default "0" is: Debounced inputs for interrupt generation

Table 6.3.6 Register OPTNoPullPA

Bit	Name	power on value	R/W	Description
3	NoPullPA[3]	0	R/W	Pull-up/down selection on PA[3]
2	NoPullPA[2]	0	R/W	Pull-up/down selection on PA[2]
1	NoPullPA[1]	0	R/W	Pull-up/down selection on PA[1]
0	NoPullPA[0]	0	R/W	Pull-up/down selection on PA[0]

Default "0" depending on mask selection

6.4.2 Pull-up or Pull-down

On each terminal of PB[3:0] an internal input pull-up (metal mask MPBPU[n]) or pull-down (metal mask MPBPD[n]) resistor can be connected per metal mask option (ROM version only). Per default the two resistors are in place. In this case one can chose per software to have either a pull-up, a pull-down or no resistor. See below.

For Metal mask selection and available resistor values refer to chapter 0.

Pull-down ON : MPBPD[n] must be in place ,
AND bit **NoPdPB**[n] must be '0' .

Pull-down OFF: MPBPD[n] is not in place,
OR if MPBPD[n] is in place **NoPdPB**[n] = '1' cuts off the pull-down.
OR selecting **NchOpDPB**[n] = '1' cuts off the pull-down.

Pull-up ON * : MPBPU[n] must be in place,
AND bit **NchOpDPB**[n] must be '1' ,
AND (bit **PBIOCntI**[n] = '0' (input mode) **OR** if **PBIOCntI**[n] = '1' while **PBData**[n] = 1.)

Pull-up OFF* : MPBPU[n] is not in place,
OR if MPBPU[n] is in place **NchOpDPB**[n] = '0' cuts off the pull-up,
OR if MPBPU[n] is in place and if **NchOpDPB**[n] = '1' then **PBData**[n] = 0 cuts off the pull-up.

Never pull-up and pull-down can be active at the same time.

For **POWER SAVING** one can switch off the port B pull resistors between two read phases. No cross current flows in the input amplifier while the port B is not read. The recommended order is :

- Switch on the pull resistor.
- Allow sufficient time - RC constant - for the pull resistor to drive the line to either V_{SS} or V_{DD} .
- Read the port B
- Switch off the pull resistor

Minimum time with current on the pull resistor is 4 system clock periods, if the RC time constant is lower than 1 system clock period. Adding a NOP instruction before reading moves the number of periods with current in the pull resistor to 6 and the maximum RC delay to 3 clock periods.

6.4.3 CMOS / NCH. Open Drain Output

The port B outputs can be configured as either CMOS or Nch. open drain outputs. In CMOS both logic '1' and '0' are driven out on the terminal. In Nch. Open Drain only the logic '0' is driven on the terminal, the logic '1' value is defined by the internal pull-up resistor (if implemented), or high impedance.

Figure 12. CMOS or Nch. Open Drain Outputs

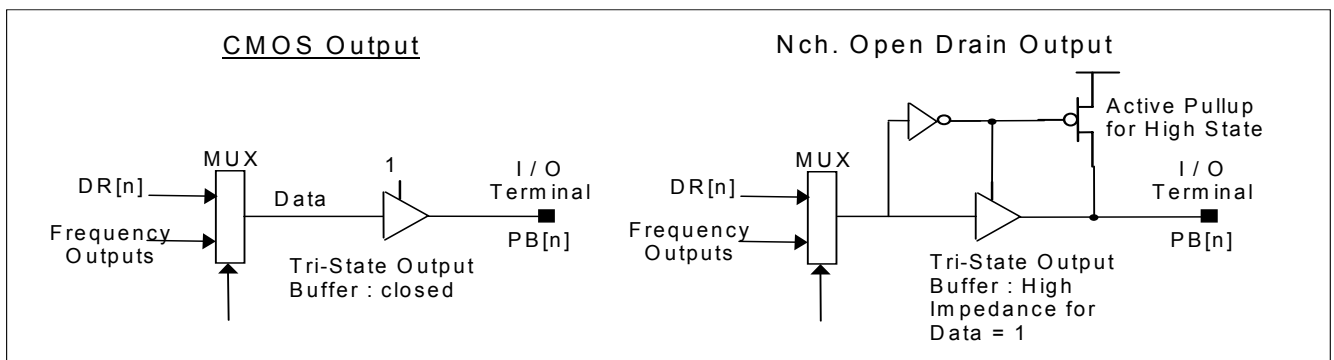

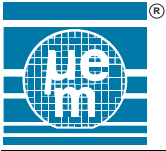

6.4.4 PWM and Frequency Output

PB[3] can also be used to output the PWM (Pulse Width Modulation) signal from the 10-Bit Counter, the Ck[16], Ck[11] as well as the Ck[1] prescaler frequencies.

- Selecting PWM output on PB[3] with bit **PWMOn** in register **RegPresc** and running the counter.
- Selecting Ck[16] output on PB[2] with bit **PB32kHzOut** in register **OPTFSeIPB**
- Selecting Ck[11] output on PB[1] with bit **PB1kHzOut** in register **OPTFSeIPB**
- Selecting Ck[1] output on PB[0] with bit **PB1HzOut** in register **OPTFSeIPB**

6.5 Port B Registers

Table 6.5.1 Register RegPBData

Bit	Name	Reset	R/W	Description
3	PBData[3]	-	R*/W	PB[3] input and output
2	PBData[2]	-	R*/W	PB[2] input and output
1	PBData[1]	-	R*/W	PB[1] input and output
0	PBData[0]	-	R*/W	PB[0] input and output

* : Direct read on the port B terminal (not the internal register)

Table 6.5.2 Register RegPBCntI

Bit	Name	Reset	R/W	Description
3	PBIOCntI[3]	0	R/W	I/O control for PB[3]
2	PBIOCntI[2]	0	R/W	I/O control for PB[2]
1	PBIOCntI[1]	0	R/W	I/O control for PB[1]
0	PBIOCntI[0]	0	R/W	I/O control for PB[0]

Default "0" is: port B in input mode

Table 6.5.3 Option Register OPTFSeIPB

Bit	Name	power on value	R/W	Description
3	<i>InpResSleep</i>	0	R/W	<i>Reset from sleep with port A</i>
2	PB32kHzOut	0	R/W	Ck[16] output on PB[2]
1	PB1kHzOut	0	R/W	Ck[11] output on PB[1]
0	PB1HzOut	0	R/W	Ck[1] output on PB[0]

Default "0" is: No frequency output, port A Input Reset can not reset the SLEEP mode.

Table 6.5.4 Option Register OPTNoPdPB

Bit	Name	power on value	R/W	Description
3	NoPdPB[3]	0	R/W	No pull-down on PB[3]
2	NoPdPB[2]	0	R/W	No pull-down on PB[2]
1	NoPdPB[1]	0	R/W	No pull-down on PB[1]
0	NoPdPB[0]	0	R/W	No pull-down on PB[0]

Default "0" is: Pull-down on

Table 6.5.5 Option Register OPTNchOpDPB

Bit	Name	power on value	R/W	Description
3	NchOpDPB[3]	0	R/W	Nch. Open Drain on PB[3]
2	NchOpDPB[2]	0	R/W	Nch. Open Drain on PB[2]
1	NchOpDPB[1]	0	R/W	Nch. Open Drain on PB[1]
0	NchOpDPB[0]	0	R/W	Nch. Open Drain on PB[0]

Default "0" is: CMOS output

6.6 Port Serial

The EM6521 contains a simple, half duplex three wire synchronous type serial interface., which can be used to program or read an external EEPROM, ADC, ... etc.

For data reception, a shift-register converts the serial input data on the SIN(PSP[0]) terminal to a parallel format, which is subsequently read by the CPU in registers **RegSDataL** and **RegSDataH** for low and high nibble. To transmit data, the CPU loads data into the shift register, which then serializes it on the SOUT(PSP[2]) terminal. It is possible for the shift register to simultaneously shift data out on the SOUT terminal and shift data on the SIN terminal. In Master mode, the shifting clock is supplied internally by the Prescaler : one of three prescaler frequencies are available, Ck[16], Ck[15] or Ck[14]. In Slave mode, the shifting clock is supplied externally on the SCLKIn(PSP[3]) terminal. In either mode, it is possible to program : the shifting edge, shift MSB first or LSB first and direct shift output. All these selection are done in register **RegSCnt1** and **RegSCnt2**.

Figure 13. Serial Interface Architecture

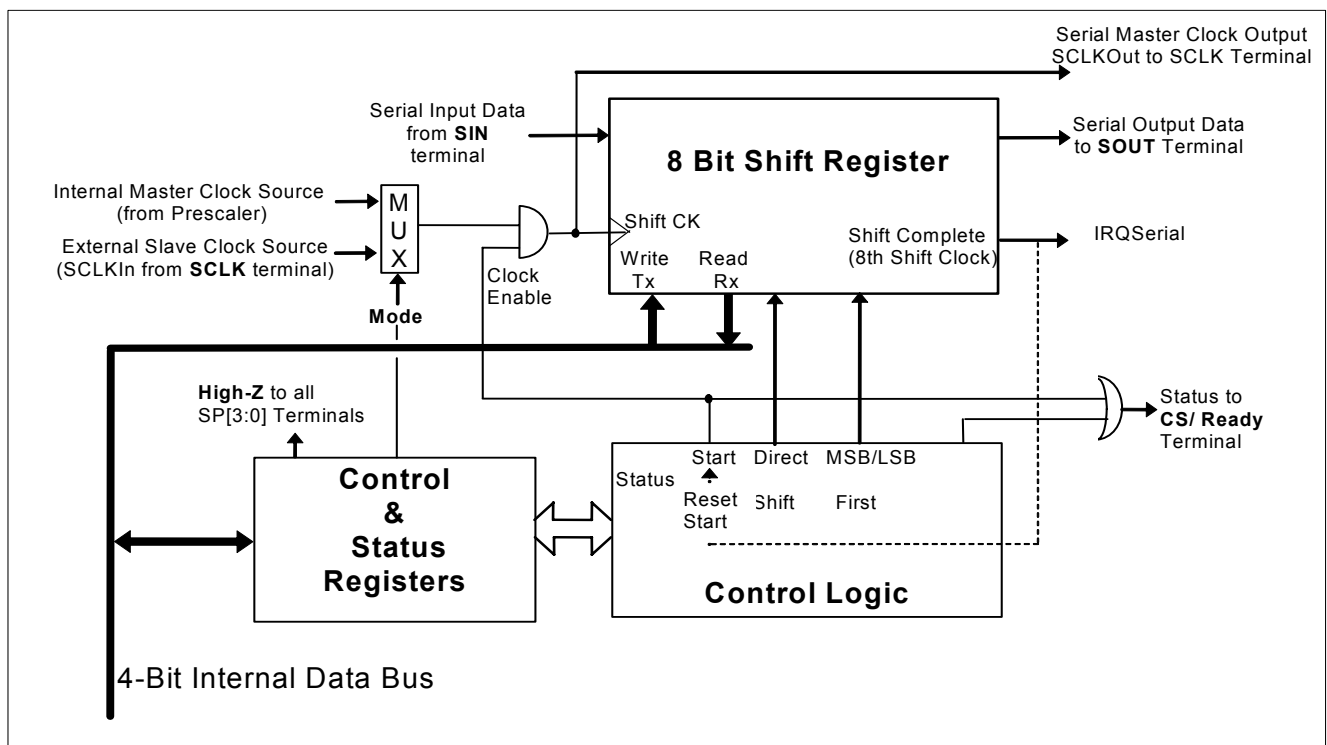

The PSP[3..0] terminal configuration is shown in Figure 14. When the Serial Interface is active then :

- * PSP[1] {Ready / CS} is outputting the ready (slave mode) or the CS signal (master mode).
- * PSP[2] {SOUT} is always an output.
- * PSP[0] {SIN} is always an input.
- * PSP[3] {SCLK} is an output for Master mode {SCLKOut} and an input for Slave mode {SCLKIn}

6.6.1 4-bit Parallel I/O

Selecting **OM[1],OM[0] = '1'** in register **RegSCnt2** the PSP[3:0] terminals are configured as a 4-bit Output. Output data is stored in the register **RegSPData** .

The **RegSPData** is defined as a read/write register, but what is read is not the register output, but the port PSP[3:0] terminal values

Selecting **OM[1],OM[0] = '0'** in register **RegSCnt2** the PSP[3:0] outputs are cut off (tristate). The terminals can be used as inputs with individual (bit-wise) pull-up or pull-down settings.

Independent of the selected configuration, the PSP[3:0] terminal levels are always readable.

Figure 14. Port SP Terminal Configuration

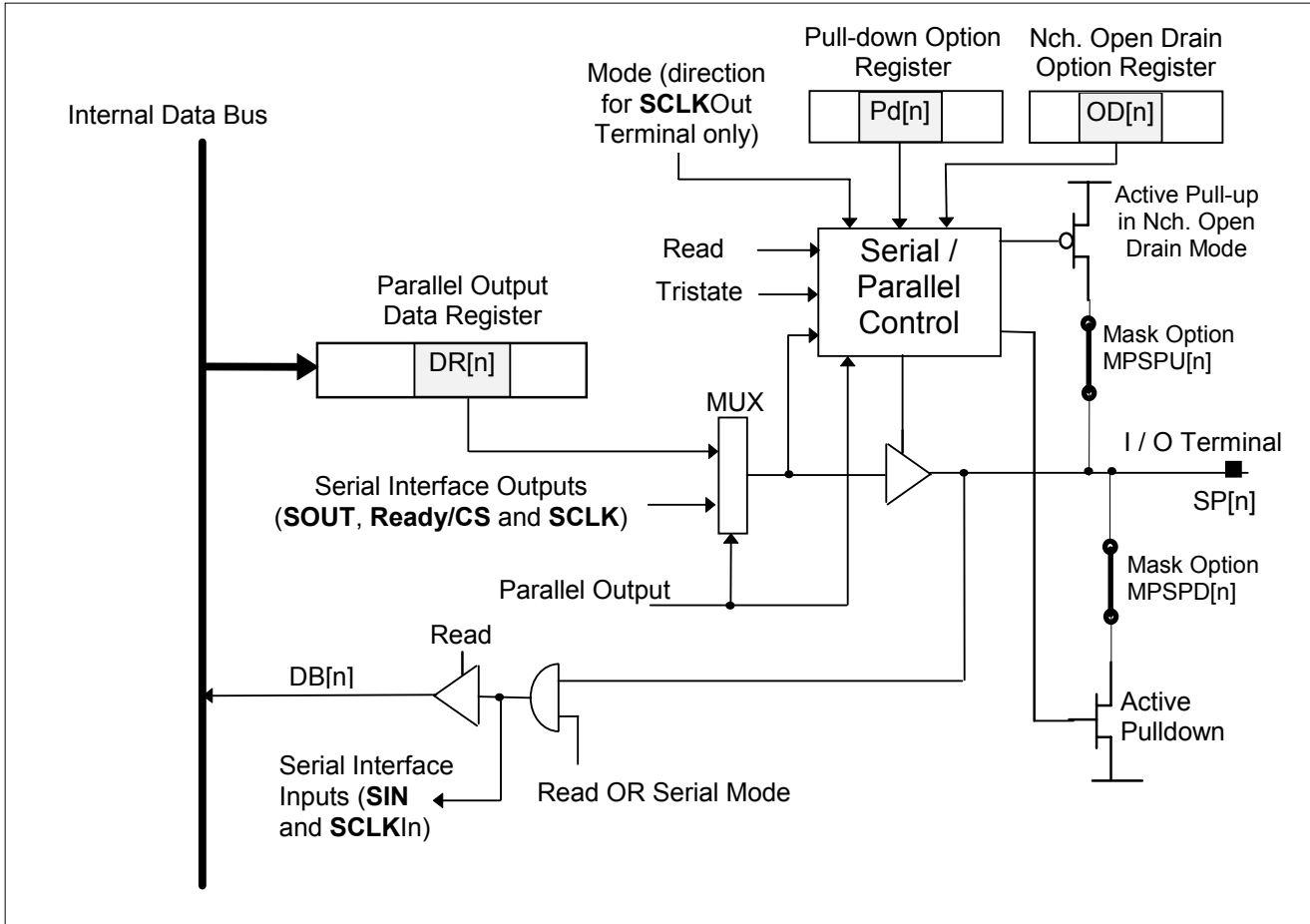

6.6.2 Pull-up or Pull-down

For each terminal of PSP[3:0] an input pull-up (metal mask MPSPU[n]) or pull-down (metal mask MPSPD[n]) resistor can be implemented per metal mask option (ROM version only). Per default the two metal masks are in place, so one can chose per software to have either a pull-up, a pull-down or no resistor. For Metal mask selection and available resistor values refer to chapter **Error! Reference source not found.**

Pull-down ON : MPSPD[n] must be in place ,
AND the bit **NoPdPS[n]** must be '0' .

Pull-down OFF: MPSPD[n] is not in place,
OR if MPSPD[n] is in place **NoPdPS[n]** = '1' cuts off the pull-down.
OR selecting **NchOpDPS[n]** = '1' cuts off the pull-down.

Pull-up ON * : MPSPU[n] must be in place,
AND the bit **NchOpDPS[n]** must be '1' ,
AND (the bits **OM[1,0]** in **RegSysCntl2** = '00' (input mode) **OR** any of the port SP terminals is in output mode with a logic '1' to be driven) .

Pull-up OFF* : MPSPU[n] is not in place,
OR if MPSPU[n] is in place **NchOpDPS[n]** = '0' cuts off the pull-up,
OR if MPSPU[n] is in place and **NchOpDPS[n]** = '1' then **SerPData[n]** = 0 cuts off the pull-up.

For **POWER SAVING** one can switch off the port SP pull resistors between two read phases. No cross current flows in the input amplifier while the port SP is not read.

This power saving feature must only be used in tristate mode (OM[0,1]=0). The recommended order is :

- switch on the pull resistor.
- allow sufficient time - RC constant - for the pull resistor to drive the line to either V_{SS} or V_{DD} .
- Read the port SP
- Switch off the pull resistor

Minimum time with current on the pull resistor is 4 periods of the system clock, if the RC constant is lower than 1 system clock period. Adding a NOP before reading moves the number of periods with current in the pull resistor to 6 and the maximum RC delay to 3 clock periods.

6.6.3 Nch. Open Drain Outputs

The port SP outputs can be configured as either CMOS or Nch. open drain outputs.

In CMOS both logic '1' and '0' are driven out on the terminal.

In Nch. open drain only the logic '0' is driven out on the terminal, the logic '1' value is high impedance or defined by the internal pull-up resistor (if existing).

Figure 15. CMOS or Nch. Open Drain outputs

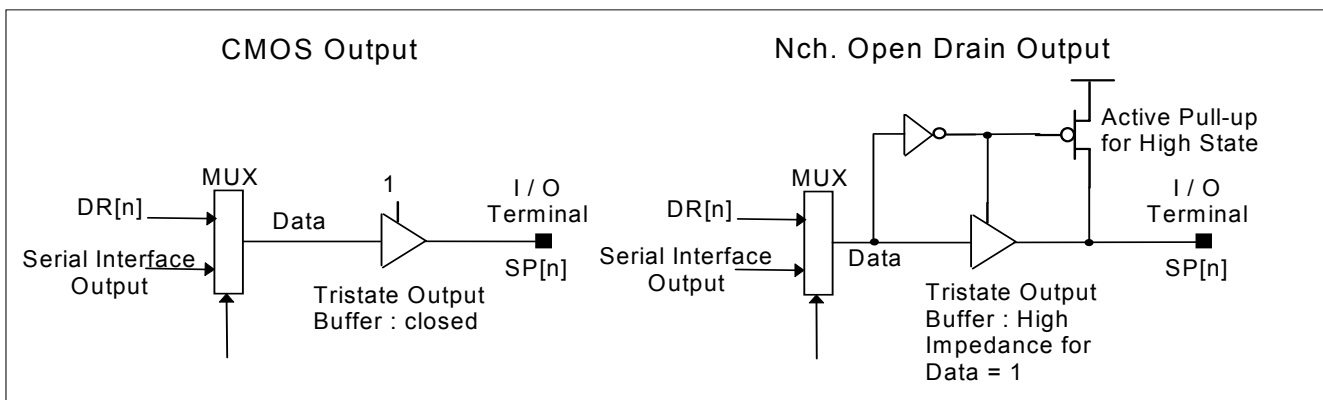

6.6.4 General Functional Description

After power on or after any reset the serial interface is in serial slave mode with **Start** and **Status** set to 0, LSB first, negative shift edge and all outputs are in high impedance state.

When the **Start** bit is set, the shift operation is enabled and the serial interface is ready to transmit or receive data, eight shift operations are performed: 8 serial data values are read from the data input terminal into the shift register and the previous loaded 8-bits are send out via the data output terminal. After the eight shift operation, an interrupt is generated, and the **Start** bit is reset.

Parallel to serial conversion procedure (master mode example).

Write to **RegSCnt1** serial control (clock freq. in master mode, edge and MSB/LSB select).

Write to **RegSDatL** and **RegSDatH** (shift out data values).

Write to **RegSCnt2** (Start=1, mode select, status).

---> Starts the shift out

After the eighth clock an interrupt is generated, **Start** becomes low. Then, interrupt handling

Serial to parallel conversion procedure (slave mode example).

Write to **RegSCnt1** (slave mode, edge and MSB/LSB select).

Write to **RegSCnt2** (Start=1, mode select, status).

After eight serial clocks an interrupt is generated, **Start** becomes low.

Interrupt handling.

Shift register **RegSDatL** and **RegSDatH** read.

A new shift operation can be authorized.

6.6.5 Detailed Functional Description

Master or Slave mode is selected in the control register **RegSCnt1**.

In Slave mode, the serial clock comes from an external device and is input via the PSP[3] terminal as a synchronous clock (SCLKIn) to the serial interface. The serial clock is ignored as long as the **Start** bit is not set. After setting **Start**, only the eight following active edges of the serial clock input PSP[3] are used to shift the serial data in and out. After eight serial clock edges the **Start** bit is reset. The PSP[1] terminal is a copy of the (**Start OR Status**) bit values, it can be used to indicate to the external master, that the interface is ready to operate or it can be used as a chip select signal in case of an external slave.

In Master mode, the synchronous serial clock is generated internally from the system clock. The frequency is selected from one out of three sources (**MS0** and **MS1** bits in **RegSCnt1**). The serial shifting clock is only generated during **Start** = high and is output to the SCLK terminal as the Master Clock (SCLKOut). When **Start** is low, the serial clock output on PSP[3] is 0.

An interrupt request **IRQSerial** is generated after the eight shift operations are done. This signal is set by the last negative edge of the serial interface clock on PSP[3] (master or slave mode) and is reset to 0 by the next write of **Start** or by any reset. This interrupt can be masked with register **RegIRQMask3**. For more details about the interrupt handling see chapter 10.

Serial data input on PSP[0] is sampled by the positive or negative serial shifting clock edge, as selected by the Control Register **POSnNeg** bit. Serial data input is shifted in LSB first or MSB first, as selected by the Control Register **MSBnLSB** bit.

6.6.6 Output Modes

Serial data output is given out in two different ways (Refer also to Figure 16 and Figure 17).

- **OM[1] = 1, OM[0] = 0 :**

The serial output data is generated with the selected shift register clock (**POSnNeg**). The first data bit is available directly after the **Start** bit is set.

- **OM[1] = 0, OM[0] = 1 :**

The serial output data is re-synchronized by the positive serial interface clock edge, independent of the selected clock shifting edge. The first data bit is available on the first positive serial interface clock edge after **Start**='1'.

Figure 16. Direct or Re-Synchronized Output

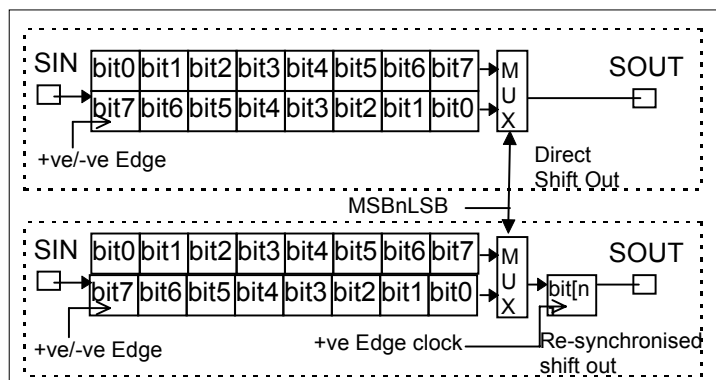
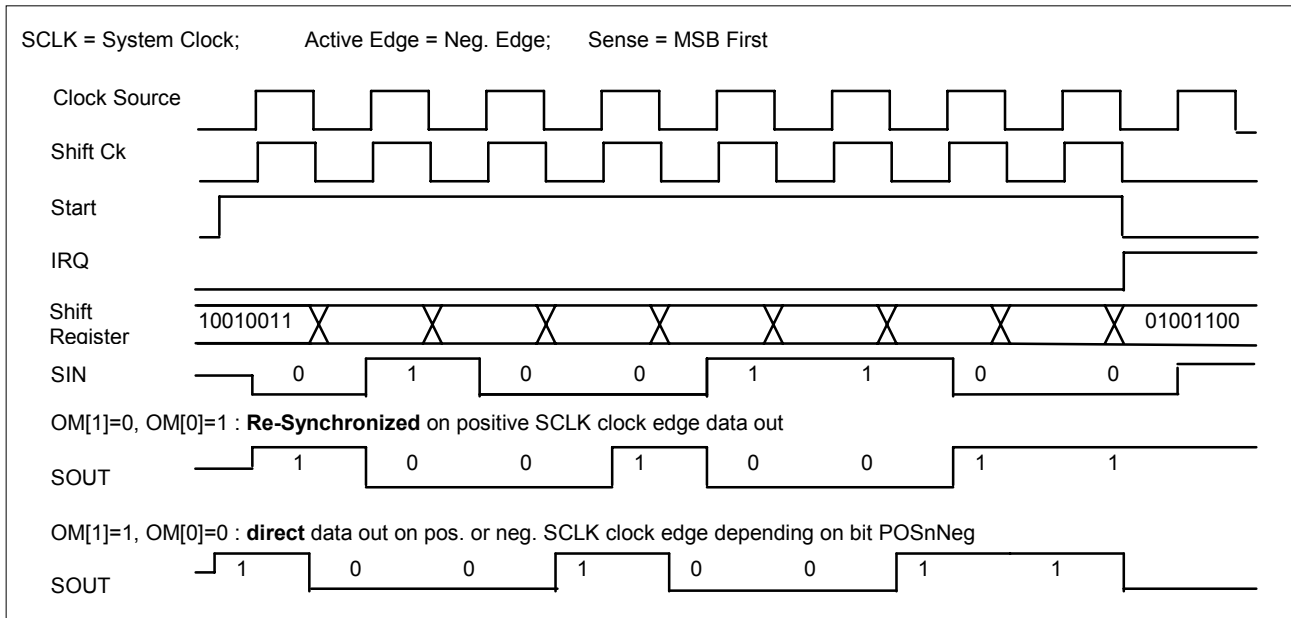

Table 6.6.6 Output Mode Selection in RegSCnt2

OM[1]	OM[0]	Output mode	Description
0	0	Tristate	Output disable (tristate on PSP[3:0])
0	1	Serial-Synchronized	Re-synchronized positive edge data shift out
1	0	Serial-Direct	Direct shift pos. or neg. edge data out
1	1	Parallel	Parallel port SP output

Tristate output is selected by default.

Figure 17 Shift Operation and IRQ Generation



6.6.7 Reset and Sleep on Port SP

During circuit initialization, all option registers are reset by Power On Reset and therefore all pull-ups are off and all pull-downs are on. During Sleep mode, Port SP inputs are cut-off, the circuit is in Reset State. However the Reset State does not reset the option registers and pull-downs, if previously turned on, remain on even during Sleep mode. After any reset the serial interface parameters are reset to : Slave mode, Start and Status = 0, LSB first, negative edge shift, PSP[3:0] tristate.

Note : A write operation in the control registers or in the data registers while **Start** is high will change internal values and may cause an error condition. The user must take care of the serial interface status before writing internal registers. In order to read the correct values on the data registers, the shift operation must be halted during the read accesses.

Figure 18. Sample Basic Serial Port Connections

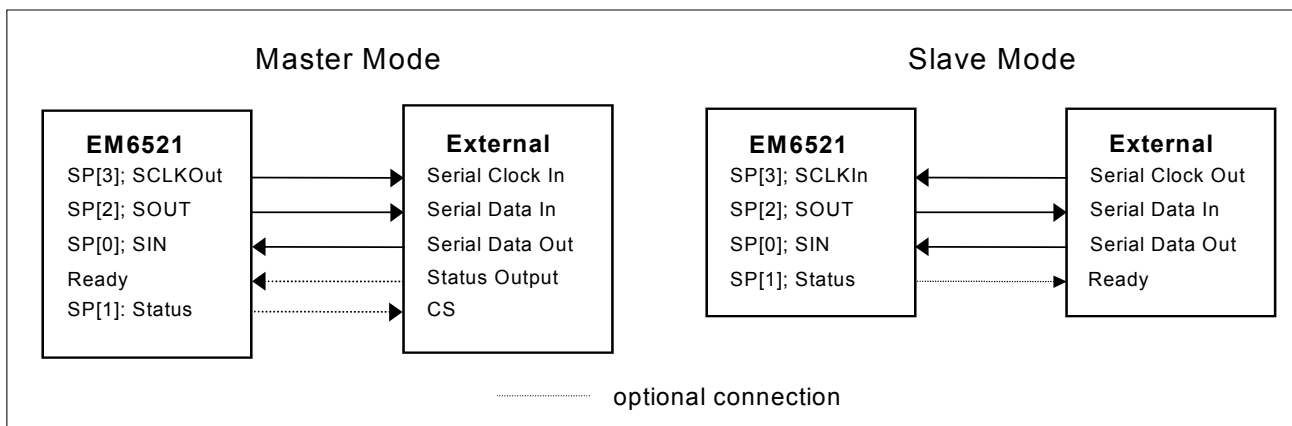



6.7 Serial Interface Registers

Table 6.7.1 Register RegSCntI1

Bit	Name	Reset	R/W	Description
3	MS1	0	R/W	Frequency selection
2	MS0	0	R/W	Frequency selection
1	POSnNeg	0	R/W	Positive or negative clock edge selection for shift operation
0	MSBnLSB	0	R/W	Shift MSB or LSB value first

Default "0" is: Slave mode external clock, negative edge, LSB first

Table 6.7.2 Frequency and Master Slave Mode Selection

MS1	MS0	Description
0	0	Slave mode: Clock from external
0	1	Master mode: System clock / 4
1	0	Master mode: System clock / 2
1	1	Master mode: System clock

Table 6.7.3 Register RegSCntI2

Bit	Name	Reset	R/W	Description
3	Start	0	R/W	Enabling the interface,
2	Status	0	R/W	Ready or Chip Select output on PSP[1]
1	OM[1]	0	R/W	Output mode select 1
0	OM[0]	0	R/W	Output mode select 0

Default "0" is: Interface disabled, status 0, serial mode, output tristate.

Table 6.7.4 Register RegSDataL

Bit	Name	Reset	R/W	Description
3	SerDataL[3]	0	R/W	Serial data low nibble
2	SerDataL[2]	0	R/W	Serial data low nibble
1	SerDataL[1]	0	R/W	Serial data low nibble
0	SerDataL[0]	0	R/W	Serial data low nibble

Default "0" is: Data equal 0.

Table 6.7.5 Register RegSDataH

Bit	Name	Reset	R/W	Description
3	SerDataH[3]	0	R/W	Serial data high nibble
2	SerDataH[2]	0	R/W	Serial data high nibble
1	SerDataH[1]	0	R/W	Serial data high nibble
0	SerDataH[0]	0	R/W	Serial data high nibble

Default "0" is: Data equal 0.

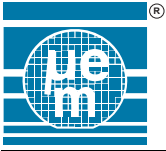

Table 6.7.6 Register RegSPData

Bit	Name	Reset	R/W	Description
3	SerPData[3]	0	R* /W	Parallel output data
2	SerPData[2]	0	R* /W	Parallel output data
1	SerPData[1]	0	R* /W	Parallel output data
0	SerPData[0]	0	R* /W	Parallel output data

R* : The input terminal value is read, not the register

Table 6.7.7 Option Register OPTNoPdPS

Bit	Name	Reset	R/W	Description
3	NoPdPS[3]	0	R/W	No pull-down on PSP[3]
2	NoPdPS[2]	0	R/W	No pull-down on PSP[2]
1	NoPdPS[1]	0	R/W	No pull-down on PSP[1]
0	NoPdPS[0]	0	R/W	No pull-down on PSP[0]

Default "0" is: Pull-down on

Table 6.7.8 Option Register OPTNchOpDPS

Bit	Name	Reset	R/W	Description
3	NchOpDPS[3]	0	R/W	Nch. Open Drain on PSP[3]
2	NchOpDPS[2]	0	R/W	Nch. Open Drain on PSP[2]
1	NchOpDPS[1]	0	R/W	Nch. Open Drain on PSP[1]
0	NchOpDPS[0]	0	R/W	Nch. Open Drain on PSP[0]

Default "0" is: CMOS output

7 Melody, Buzzer

A normal application is to drive a buzzer connected onto the terminal Buzzer.

This peripheral cell is a combination of a 7 frequency tone generator and a 4-bit timer, used to provide a 50% duty cycle signal on the Buzzer terminal of a pre-selected length and frequency. The Buzzer terminal is active as long as the timer is not 0 or the **SwBuzzer** is set to '1'. The 4-bit timer can be used for another application independent of the Buzzer terminal by selecting "silence" instead of another frequency on the Buzzer output. "Silence" can also be used as part of a melody, or to switch off the buzzer.

To use the buzzer independent of the 4-bit timer one has to set the switch **SwBuzzer**. This bit is in register **RegMeITim** and selects the signal duration on the buzzer output. If **SwBuzzer**=1 then the signal is output until the bit is set back to 0. With **SwBuzzer**=0 the output signal duration is controlled by the 4bit timer. If neither the **SwBuzzer** or the timer are active, the Buzzer terminal is on 0.

The high impedance state setting with **BzOutEn** is independent of the **SwBuzzer** and Timer settings. As soon as the bit is set to 1 the Buzzer terminal is set tristate. See also Figure 19.

Figure 19. Melody Generator Block Diagram

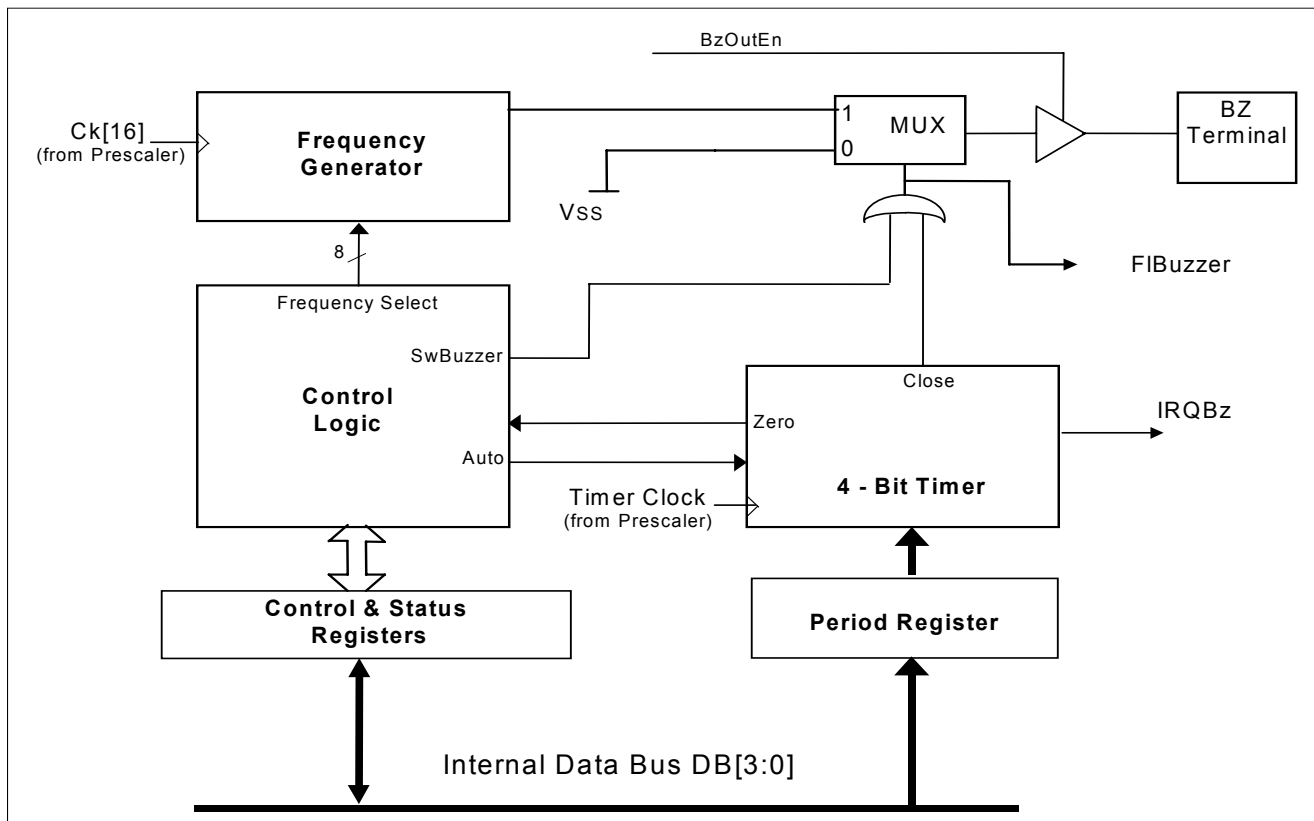

7.1 4-Bit Timer

The timer has 2 modes:

- Single run mode (**Auto**=0)
- Continuous run mode (**Auto**=1)

Mode selection and timer count down frequency is done in register **RegMeITim**. All timer frequencies are coming from the prescaler. The 4-bit timer can be used independent of the melody buzzer application.

Whenever the timer reaches 0 it generates an interrupt request **IRQBz** in the register **RegIRQ2**. This interrupt can be masked with the bit **MaskIRQBz** in register **RegIRQMask2**. By writing 0 into the timer period register the timer stops immediately and does not generate an interrupt.

7.1.1 Single Run Mode

The timer duration is controlled by the **RegMeIPeri** value and the selected timer frequency in **RegMeITim**. The timer is counting down from its previously charged value until it reaches 0. On 0 the timer stops and generates an interrupt request. The buzzer frequency output is enabled after the next positive timer clock edge and remains enabled until the timer reaches 0.

Figure 20. Single Run Mode

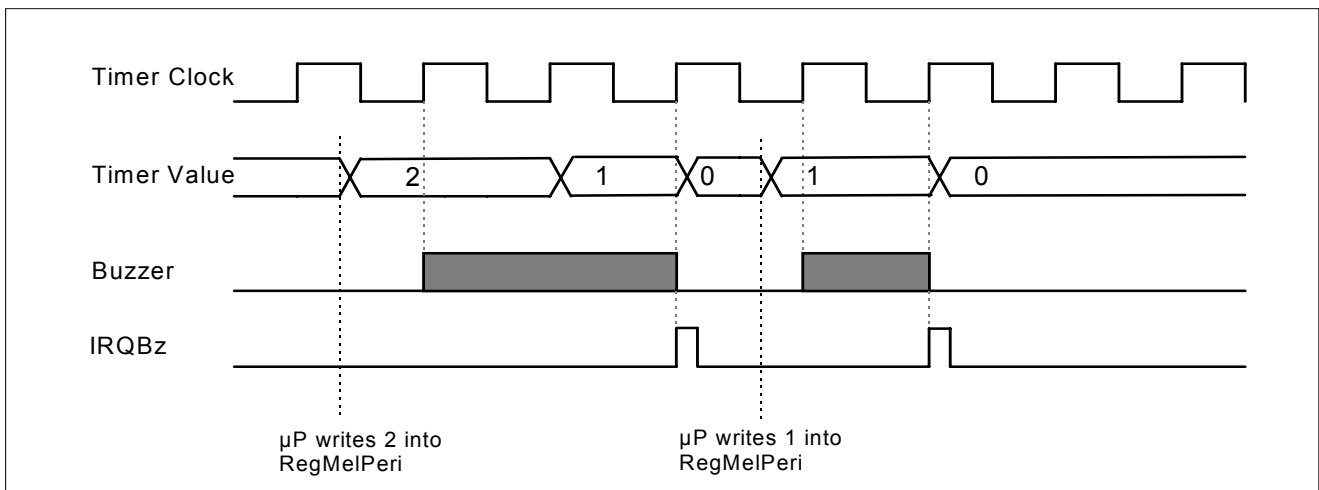

7.1.2 Continuous Run Mode

This is almost the same as the single run mode only that in this case the timer after reaching 0 reloads itself automatically with the register **RegMeIPeri** value. Every time the timer reaches 0 an interrupt request is send. There are 2 ways to stop the continuous mode.

- First, changing the mode to single run mode. As the timer reaches 0 it stops. The last period after **Auto=0** is of length **RegMeIPeri + 1**.
- Second, loading 0 into the timer period register **RegMeIPeri** stops the timer immediately, no interrupt is generated and the **Auto** flag is reset. The buzzer frequency output is enabled directly by writing **Auto=1**.

Figure 21. Continuous Run Mode

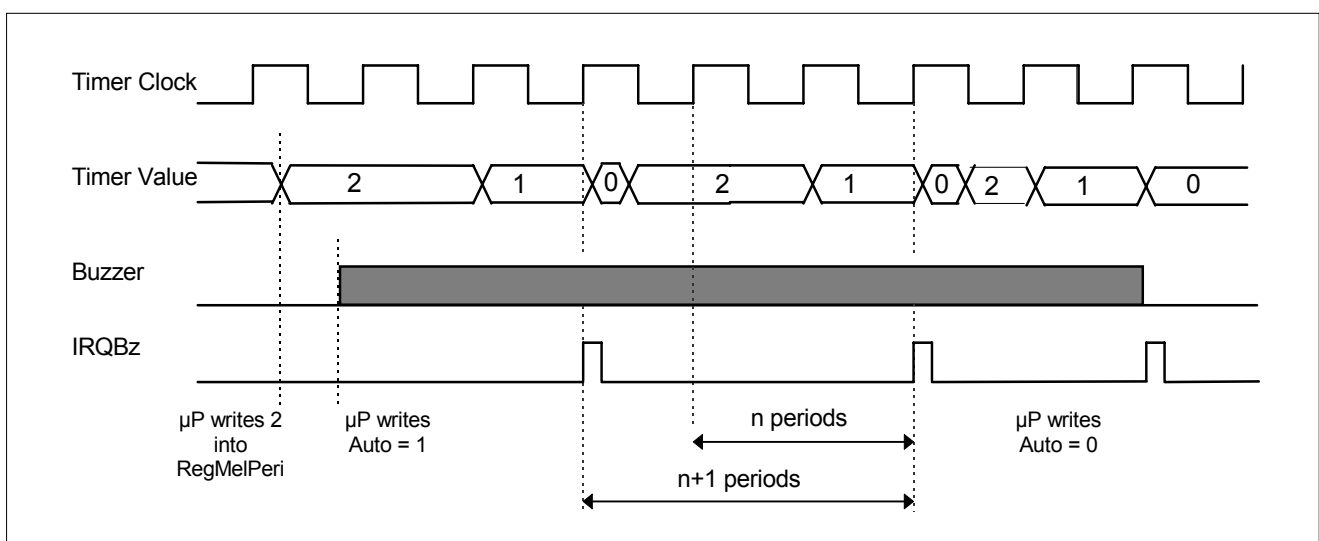



7.2 Programming Order

Single run mode usage

- 1st, selecting the buzzer frequency into **RegMelFSel**.
- 2nd, selecting the timer clock frequency in **RegMelTim**.
- 3rd, selecting the timer period in **RegMelPeri**.
- > On the next positive clock edge the buzzer output is enabled.

Continuos run mode usage

- 1st, selecting the buzzer frequency into **RegMelFSel**.
- 2nd, selecting the timer clock frequency in **RegMelTim (Auto=0)**.
- 3rd, selecting the timer period in **RegMelPeri**.
- 4th, set bit **Auto** in **RegMelTim**.
- > Immediately the buzzer output is active.

Avoid timer clock frequency switch during buzzer operation.

7.3 Melody Registers

Table 7.3.1 Register RegMelFSel

Bit	Name	Reset	R/W	Description
3	BzOutEn	0	R/W	Buzzer Output tristate
2	MelFSel[2]	0	R/W	Buzzer frequency select
1	MelFSel[1]	0	R/W	Buzzer frequency select
0	MelFSel[0]	0	R/W	Buzzer frequency select

Default : Buzzer tristate, silence

Table 7.3.2 Buzzer Output Frequency Selection with MelFSel[2..0]

MelFSel[2]	MelFSel[1]	MelFSel[0]	Frequency	
0	0	0	V _{ss} (silence)	
0	0	1	SysClock/8	DO8
0	1	0	SysClock/10	SOL7#
0	1	1	SysClock/12	FA7
1	0	0	SysClock/14	RE7
1	0	1	SysClock/16	DO7
1	1	0	SysClock/20	SOL6#
1	1	1	SysClock/24	FA6

Table 7.3.3 Register RegMelTim

Bit	Name	Reset	R/W	Description
3	SwBuzzer	0	W	Write: switch buzzer
	FIBuzzer	0	R	Read: flag buzzer
2	Auto	0	R/W	Single or continuos run mode
1	FTimSel1	0	R/W	Timer clock frequency select
0	FTimSel0	0	R/W	Timer clock frequency select

Default : Single run mode, Ck[3] from prescaler as timer clock

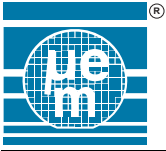

Table 7.3.4 Timer Clock Frequency Select

FTimSel0	FTimSel1	Timer Clock	On 32 KHz operation
0	0	Ck[3]	4 Hz
1	0	Ck[5]	16 Hz
0	1	Ck[7]	64 Hz
1	1	Ck[1]	1 Hz

Table 7.3.5 Register RegMelPeri

Bit	Name	Reset	R/W	Description
3	Per[3]	0	W	Melody timer period MSB
2	Per[2]	0	W	Melody timer period
1	Per[1]	0	W	Melody timer period
0	Per[0]	0	W	Melody timer period LSB

The total timer period duration is calculated as following:

$$\text{Duration} = \text{Value}(\text{RegMelPeri}) \times 1/\text{Ck}[n]$$

Where, Ck[n] is the timer clock frequency and Value(RegMelPeri) is the value of the register **RegMelPeri**.

8 10-bit Counter

The EM6521 has a built-in universal cyclic counter. It can be configured as 10, 8, 6 or 4-bit counter. If 10-bits are selected we call that **full bit** counting, if 8, 6 or 4-bits are selected we call that **limited bit** counting.

The counter works in up- or down count mode. Eight clocks can be used as the input clock source, six of them are prescaler frequencies and two are coming from the input pads PA[0] and PA[3]. In this case the counter can be used as an event counter.

The counter generates an interrupt request **IRQCount0** every time it reaches 0 in down count mode or 3FF in up count mode. Another interrupt request **IRQCntComp** is generated in compare mode whenever the counter value matches the compare data register value. Each of this interrupt requests can be masked (default). See section 10 for more information about the interrupt handling.

A 10-bit data register **CReg[9:0]** is used to initialize the counter at a specific value (load into **Count[9:0]**). This data register (**CReg[9:0]**) is also used to compare its value against **Count[9:0]** for equivalence.

A Pulse-Width-Modulation signal (PWM) can be generated and output on port B terminal PB[3].

Figure 22. 10-bit Counter Block Diagram

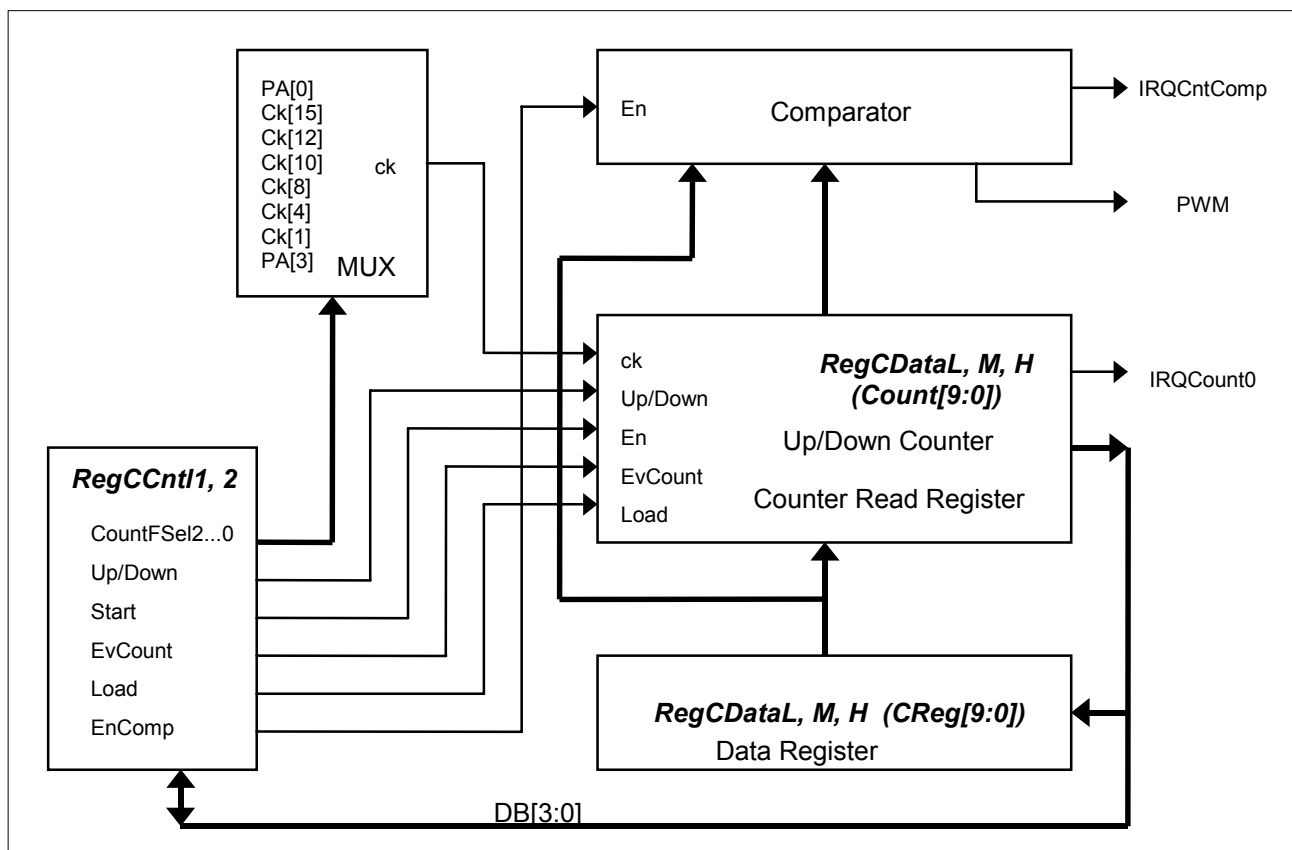

8.1 Full and Limited Bit Counting

In Full Bit Counting mode the counter uses its maximum of 10-bits length (default). With the **BitSel[1,0]** bits in register **RegCDataH** one can lower the counter length, for IRQ generation, to 8, 6 or 4 bits. This means that actually the counter always uses all the 10-bits, but **IRQCount0** generation is only performed on the number of selected bits. The unused counter bits may or may not be taken into account for the **IRQComp** generation depending on bit **SelIntFull**. Refer to chapter 8.4.

Table 7.3.1. Counter length selection

BitSel[1]	BitSel[0]	counter length
0	0	10-Bit
0	1	8-Bit
1	0	6-Bit
1	1	4-Bit

8.2 Frequency Select and Up/Down Counting

8 different input clocks can be selected to drive the Counter. The selection is done with bits **CountFSel2...0** in register **RegCCnt1**. 6 of this input clocks are coming from the prescaler. The maximum prescaler clock frequency for the counter is half the system clock and the lowest is 1Hz. Therefore a complete counter roll over can take as much as 17.07 minutes (1Hz clock, 10 bit length) or as little as 977 μ s (Ck[15], 4 bit length). The **IRQCount0**, generated at each roll over, can be used for time bases, measurements length definitions, input polling, wake up from Halt mode, etc. The **IRQCount0** and **IRQComp** are generated with the system clock Ck[16] rising edge. **IRQCount0** condition in up count mode is : reaching 3FF if 10-bit counter length (or FF, 3F, F in 8, 6, 4-bit counter length). In down count mode the condition is reaching '0'. The non-selected bits are 'don't care'. For **IRQComp** refer to section 8.4.

Note: The Prescaler and the Microprocessor clock's are usually non-synchronous, therefore time bases generated are max. n, min. n-1 clock cycles long (n being the selected counter start value in count down mode). However the prescaler clock can be synchronized with μ P commands using for instance the prescaler reset function.

Figure 23. Counter Clock Timing

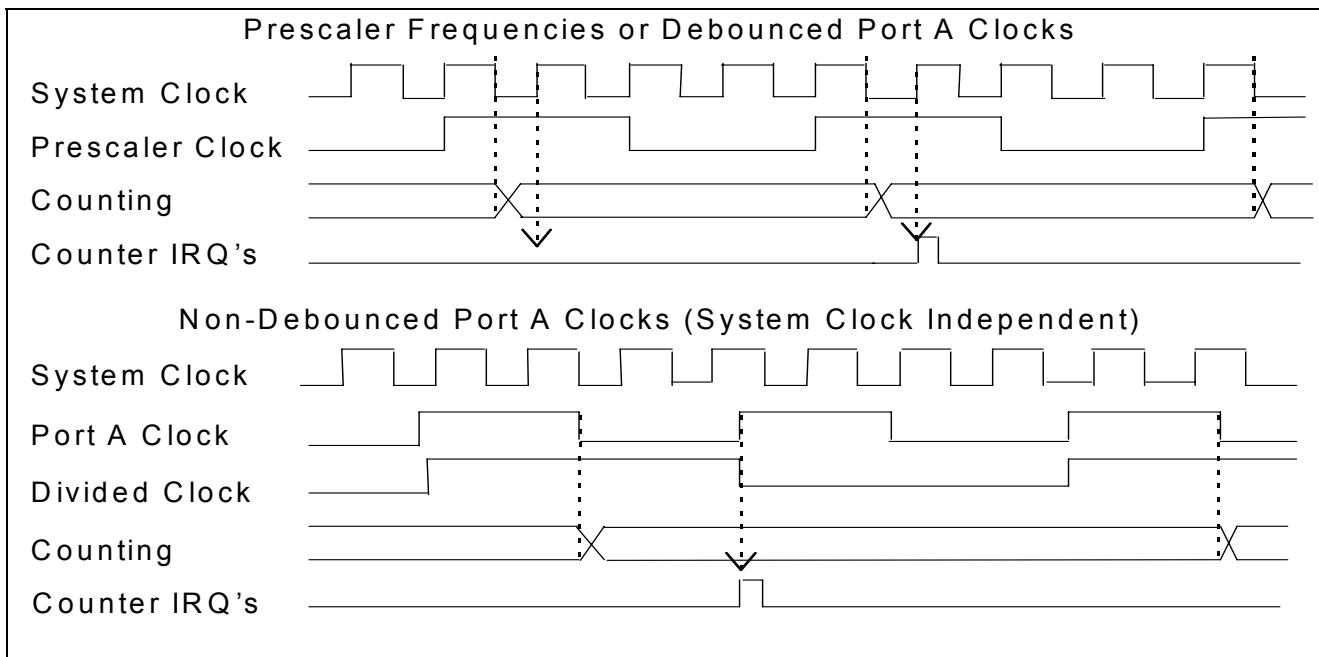

The two remaining clock sources are coming from the PA[0] or PA[3] terminals. Refer to the Figure 10 on page 15 for details. Both sources can be either debounced (Ck[11] or Ck[8]) or direct inputs, the input polarity can also be chosen. The output after the debouncer polarity selector is named PA3, PA0 respectively. For the debouncer and input polarity selection refer to chapter 6.3.

In the case of port A input clock without debouncer, the counting clock frequency will be half the input clock on port A. The counter advances on every odd numbered port A negative edge (divided clock is high level). **IRQCount0** and **IRQComp** will be generated on the rising PA3 or PA0 input clock edge. In this condition the EM6521 is able to count with a higher clock rate as the internal system clock (Hi-Frequency Input). Maximum port A input frequency is limited to 200kHz (@ $V_{DD} \geq 2.0$ V). If higher frequencies are needed, please contact EM-Marin.

In both, up or down count (default) mode, the counter is cyclic. The counting direction is chosen in register **RegCCnt1** bit **Up/Down** (default '0' is down count). The counter increases or decreases its value with each positive clock edge of the selected input clock source. Start up synchronization is necessary because one can not always know the clock status when enabling the counter. With **EvCount=0**, the counter will only start on the next positive clock edge after a previously latched negative edge, while the **Start** bit was already set to '1'. This synchronization is done differently if event count mode (bit **EvCount**) is chosen. Refer also to Figure 24. Internal Clock Synchronization.

8.3 Event Counting

The counter can be used in a special event count mode where a certain number of events (clocks) on the PA[0] or PA[3] input are counted. In this mode the counting will start directly on the next active clock edge on the selected port A input.

The Event Count mode is switched on by setting bit **EvCount** in the register **RegCCnt12** to '1'. PA[3] and PA[0] inputs can be inverted depending on register **OPTIntEdgPA** and should be debounced. The debouncer is switched on in register **OPTDeblntPA** bits **NoDeblntPA[3,0]=0**. Its frequency depends on the bit **DebSel** from register **RegPresc** setting. The inversion of the internal clock signal derived from PA[3] or PA[0] is active with **IntEdgPA[3]** respectively **IntEdgPA[0]** equal to 1. Refer also to Figure 10 for internal clock signal generation.

Figure 24. Internal Clock Synchronization

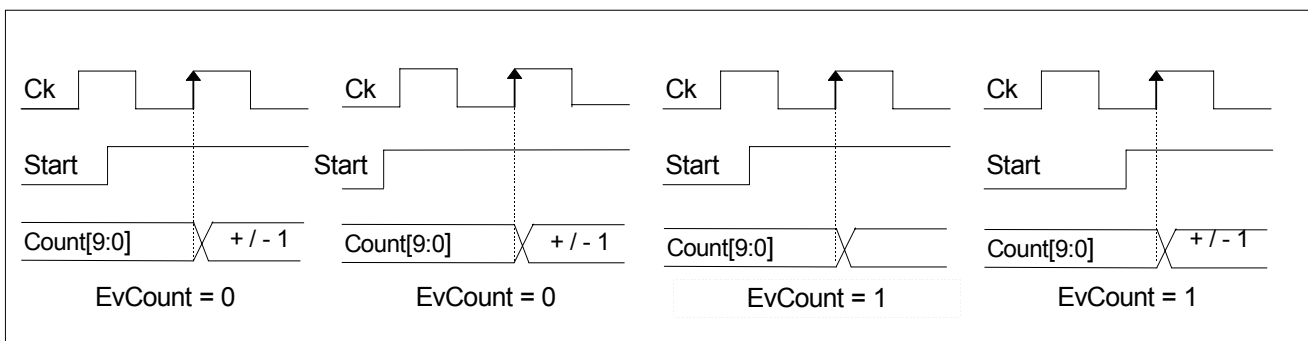

8.4 Compare Function

A previously loaded register value (**CReg[9:0]**) can be compared against the actual counter value (**Count[9:0]**). If the two are matching (equality) then an interrupt (**IRQComp**) is generated. The compare function is switched on with the bit **EnComp** in the register **RegCCnt12**. With **EnComp = 0** no **IRQComp** is generated. Starting the counter with the same value as the compare register is possible, no IRQ is generated on start. Full or Limited bit compare are possible, defined by bit **SellntFull** in register **RegSysCnt1**.

EnComp must be written after a load operation (**Load = 1**). Every load operation resets the bit **EnComp**.

Full bit compare function.

Bit **SellntFull** is set to '1'. The function behaves as described above independent of the selected counter length. Limited bit counting together with full bit compare can be used to generate a certain amount of **IRQCount0** interrupts until the counter generates the **IRQComp** interrupt. With **PWMOn='1'** the counter would have automatically stopped after the **IRQComp**, with **PWMOn='0'** it will continue until the software stops it. **EnComp** must be cleared before setting **SellntFull** and before starting the counter again. Be careful, **PWMOn** also redefines the port B PB[3] output data. (refer to section 8.5).

Limited bit compare

With the bit **SellntFull** set to '0' (default) the compare function will only take as many bits into account as defined by the counter length selection **BitSel[1:0]** (see chapter 8.1).

8.5 Pulse Width Modulation (PWM)

The PWM generator uses the behavior of the Compare function (see above) so **EnComp** must be set to activate the PWM function.. At each Roll Over or Compare Match the PWM state - which is output on port B PB[3] - will toggle. The start value on PB[3] is forced while **EnComp** is 0 the value is depending on the up or down count mode. Every counter value load operation resets the bit **EnComp** and therefore the PWM start value is reinstalled.

Setting **PWMOn** to '1' in register **RegPresc** routes the counter PWM output to port B terminal PB[3]. Insure that PB[3] is set to output mode. Refer to section 6.4 for the port B setup.

The PWM signal generation is independent of the limited or full bit compare selection bit **SellntFull**. However if **SellntFull = 1** (FULL) and the counter compare function is limited to lower than 10 bits one can generate a predefined number of output pulses. In this case, the number of output pulses is defined by the value of the unused counter bits. It will count from the start value until the **IRQComp** match.

One must not use a compare value of hex 0 in up count mode nor a value of hex 3FF (or FF,3F, F if limited bit compare) in down count mode.

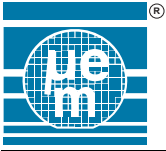

EM6521

For instance, loading the counter in up count mode with hex 000 and the comparator with hex C52 which will be identified as :

- bits[11:10] are limiting the counter to limits to 4 bits length, =03 (BitSel[1,0])
- bits [9:4] are the unused counter bits = hex 05 (bin 000101), (number of PWM pulses)
- bits [3:0] (comparator value = 2). (length of PWM pulse)

Thus after 5 PWM-pulses of 2 clocks cycles length the Counter generates an **IRQComp** and stops. The same example with SellntFull=0 (limited bit compare) will produce an unlimited number of PWM at a length of 2 clock cycles.

8.5.1 How the PWM Generator works.

For Up Count Mode; Setting the counter in up count and PWM mode the PB[3] PWM output is defined to be 0 (**EnComp**=0 forces the PWM output to 0 in upcount mode, 1 in downcount). Each Roll Over will set the output to '1' and each Compare Match will set it back to '0'. The Compare Match for PWM always only works on the defined counter length. This, independent of the SellntFull setting which is valid only for the IRQ generation. Refer also to the compare setup in chapter 8.4.

In above example the PWM starts counting up on hex 0,
 2 cycles later compare match -> PWM to '0',
 14 cycles later roll over -> PWM to '1'
 2 cycles later compare match -> PWM to '0' , etc. until the completion of the 5 pulses.

The normal IRQ generation remains on during PWM output. If no IRQ's are wanted, the corresponding masks need to be set.

Figure 25. PWM Output in Up Count Mode

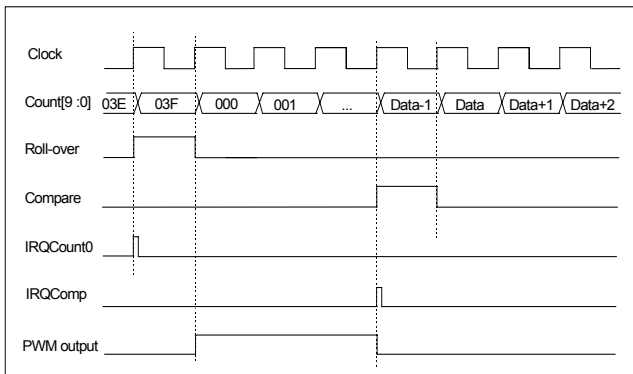
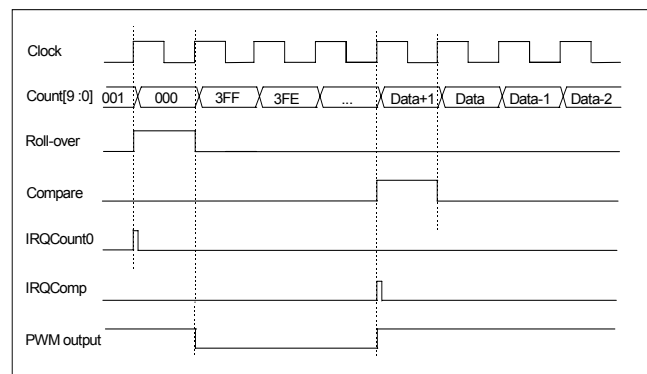

Figure 26. PWM Output in Down Count Mode



In Down Count Mode everything is inverted. The PWM output starts with the '1' value. Each Roll Over will set the output to '0' and each Compare Match will set it back to '1'. For limited pulse generation one must load the complementary pulse number value. I.e. for 5 pulses counting on 4 bits load bits[9 :4] with hex 3A (bin 111010).

8.5.2 PWM Characteristics

PWM resolution is : 10bits (1024 steps), 8bits (256 steps), 6bits (64 steps) or 4 bits (16 steps)
 the minimal signal period is : 16 (4-bit) x Fmax* -> 16 x 1/Ck[15] -> 977 µs (32 KHz)
 the maximum signal period is : 1024 x Fmin* -> 1024 x 1/Ck[1] -> 1024 s (32 KHz)
 the minimal pulse width is : 1 bit -> 1 x 1/Ck[15] -> 61 µs (32 KHz)

* This values are for Fmax or Fmin derived from the internal system clock (32kHz). Much shorter (and longer) PWM pulses can be achieved by using the port A as frequency input.

One must not use a compare value of hex 0 in up count mode nor a value of hex 3FF (or FF,3F, F if limited bit compare) in downcount mode.

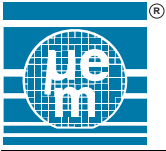

8.6 Counter Setup

RegCDataL[3:0], RegCDataM[3:0], RegCDataH[1:0] are used to store the initial count value called **CReg[9:0]** which is written into the count register bits **Count[9:0]** when writing the bit **Load** to '1' in **RegCCnt12**. This bit is automatically reset thereafter. The counter value **Count[9:0]** can be read out at any time, except when using non-debounced high frequency port A input clock. To maintain data integrity the lower nibble **Count[3:0]** must always be read first. The **ShCount[9:4]** values are shadow registers to the counter. To keep the data integrity during a counter read operation (3 reads), the counter values [9:4] are copied into these registers with the read of the count[3:0] register. If using non-debounced high frequency port A input the counter must be stopped while reading the **Count[3:0]** value to maintain the data integrity. In down count mode an interrupt request **IRQCount0** is generated when the counter reaches 0. In up count mode, an interrupt request is generated when the counter reaches 3FF (or FF,3F,F if limited bit counting).

Never an interrupt request is generated by loading a value into the counter register.

When the counter is programmed from up into down mode or vice versa, the counter value **Count[9:0]** gets inverted. As a consequence, the initial value of the counter must be programmed after the **Up/Down** selection.

Loading the counter with hex 000 is equivalent to writing stop mode, the **Start** bit is reset, no interrupt request is generated.

How to use the counter;

If PWM output is required one has to put the port B[3] in output mode and set **PWMOn=1** in step 5.

1st, set the counter into stop mode (**Start=0**).

2nd, select the frequency and up- or down count mode in **RegCCnt1**.

3rd, write the data registers **RegCDataL, RegCDataM, RegCDataH** (counter start value and length)

4th, load the counter, **Load=1**, and choose the mode. (**EvCount, EnComp=0**)

5th, select bits **PWMOn** in **RegPresc** and **SelIntFull** in **RegSysCnt1**

6th, if compare mode desired, then write **RegCDataL, RegCDataM, RegCDataH** (compare value)

7th, set bit **Start** and select **EnComp** in **RegCCnt2**

8.7 10-bit Counter Registers

Table 8.7.1 Register RegCCnt1

Bit	Name	Reset	R/W	Description
3	Up/Down	0	R/W	Up or down counting
2	CountFSel2	0	R/W	Input clock selection
1	CountFSel1	0	R/W	Input clock selection
0	CountFsel0	0	R/W	Input clock selection

Default : PA0 ,selected as input clock, Down counting

Table 8.7.2 Counter Input Frequency Selection with CountFSel[2..0]

CountFSel2	CountFSel1	CountFSel0	clock source selection
0	0	0	Port A PA[0]
0	0	1	Prescaler Ck[15]
0	1	0	Prescaler Ck[12]
0	1	1	Prescaler Ck[10]
1	0	0	Prescaler Ck[8]
1	0	1	Prescaler Ck[4]
1	1	0	Prescaler Ck[1]
1	1	1	Port A PA[3]

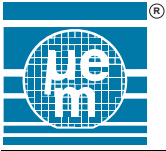

Table 8.7.3 Register RegCCntI2

Bit	Name	Reset	R/W	Description
3	Start	0	R/W	Start/Stop control
2	EvCount	0	R/W	Event counter enable
1	EnComp	0	R/W	Enable comparator
0	Load	0	R/W	Write: load counter register; Read: always 0

Default : Stop, no event count, no comparator, no load

Table 8.7.4 Register RegSysCntI1

Bit	Name	Reset	R/W	Description
3	<i>IntEn</i>	0	R/W	<i>General interrupt enable</i>
2	<i>SLEEP</i>	0	R/W	<i>Sleep mode</i>
1	SelIntFull	0	R/W	Compare Interrupt select
0	<i>ChTmDis</i>	0	R/W	<i>For EM test only</i>

Default : Interrupt on limited bit compare

Table 8.7.5 Register RegCDataL, Counter/Compare Low Data Nibble

Bit	Name	Reset	R/W	Description
3	CReg[3]	0	W	Counter data bit 3
2	CReg[2]	0	W	Counter data bit 2
1	CReg[1]	0	W	Counter data bit 1
0	CReg[0]	0	W	Counter data bit 0
3	Count[3]	0	R	Data register bit 3
2	Count[2]	0	R	Data register bit 2
1	Count[1]	0	R	Data register bit 1
0	Count[0]	0	R	Data register bit 0

Table 8.7.6 Register RegCDataM, Counter/Compare Middle Data Nibble

Bit	Name	Reset	R/W	Description
3	CReg[7]	0	W	Counter data bit 7
2	CReg[6]	0	W	Counter data bit 6
1	CReg[5]	0	W	Counter data bit 5
0	CReg[4]	0	W	Counter data bit 4
3	ShCount[7]	0	R	Data register bit 7
2	ShCount[6]	0	R	Data register bit 6
1	ShCount[5]	0	R	Data register bit 5
0	ShCount[4]	0	R	Data register bit 4

Table 8.7.7 Register RegCDataH, Counter/Compare High Data Nibble

Bit	Name	Reset	R/W	Description
3	BitSel[1]	0	R/W	Bit select for limited bit count/compare
2	BitSel[0]	0	R/W	Bit select for limited bit count/compare
1	CReg[9]	0	W	Counter data bit 9
0	CReg[8]	0	W	Counter data bit 8
1	ShCount[9]	0	R	Data register bit 9
0	ShCount[8]	0	R	Data register bit 8

Table 8.7.8 Counter Length Selection

BitSel[1]	BitSel[0]	counter length
0	0	10-Bit
0	1	8-Bit
1	0	6-Bit
1	1	4-Bit

9.3 MSC-Modes

The millisecond counter can have many different modes of operation. The most common are :

- CPU controlled start and stop.
- CPU controlled start and PA[3] controlled stop.
- Port A terminal PA[3] controlled start and stop mode.
- Pulse width measurement of port A terminal PA[3] input signals.

All these different modes are controlled with the bits in the registers **RegMSCCntl1** and **RegMSCCntl2**. The main bits are :

- **dt/MSC** ; Pulse-width or start stop measure. This bit only has a action if PA[3] input is chosen. If pulse-width measure is selected, the counter starts with the first active edge on PA[3] and stops with the next inverse edge (sets **RunEn** = 0). If MSC measure selected, the counter starts with the first active PA[3] edge, stops on the next, restarts on the following etc. It does not reset **RunEn**.
- **PA3/μP** ; Direct port A terminal PA[3] or CPU (μP) controlled start and stop function. If direct PA[3] controlled start stop mode is chosen the counter, once enabled by setting **RunEn/Stop** = 1, starts counting on the first active edge seen on PA[3]. It stops counting depending on the **dt/MSC** bit either on the next inverse edge or on the next active edge. If **μP** is chosen, the counter starts and stops depending on bit **RunEn/Stop**.
- **RunEn/Stop**; In CPU mode this bit starts or stops the counter. In PA3 mode it enables the counter which will start with the next event on port A terminal PA[3]. If **dt** and PA3 mode, the **RunEn** gets reset with the second active PA[3] edge.
- **PA3Edge** ; This bit selects the active PA[3] edge which will trigger the **dt/MSC** selected measurement mode. It has no effect if **PA3/μP**=0. Default 0 is negative edge.

9.4 Mode selection

Before using, the MSC counter needs to be reset by setting bit **ResMSC** to '1'. This bit is automatically reset thereafter. Then select the IRQ frequency and the counting mode. Now the **RunEn** can be set to '1'. To display the counter value during run you may only want to read the MSB (1/10 sec) digit ,driven by IRQ or with polling, and fully read the MSC value only once the counter is stopped. The counter data registers are read only. Any Reset (system reset, POR, watchdog) is setting the MSC into stop mode and clears the counter registers.

• CPU controlled Start and Stop

As soon as the CPU writes the start bit **RunEn/Stop**=1 the counter starts up counting until the CPU clears the start bit. The bit **PA3/uP** is '0' for this mode.

Figure 28. CPU controlled Start Stop

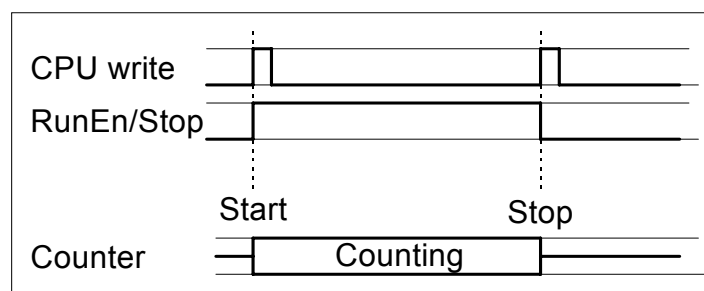

- **CPU controlled Start and PA[3] controlled Stop.**

In this mode setting the bit **RunEn=1** while **PA3/uP=0** while immediately start the counting action. Afterwards one needs to prepare for the stop by PA[3]. Therefore the PA[3] start condition must first be fulfilled. This is in **dT** mode a rising edge on the PA3internal signal (PA3internal, refer to Figure 27). In **MSC** mode the start condition is a positive pulse on PA3internal signal. The creation of this edge or pulse is done per software by manipulating the **PA3Edge** selection. See Figure 29 for details. Afterwards one can change to PA3 controlled stop mode (**PA3/uP=1**) where the next positive edge on PA3internal will stop the Counter. In **dT** mode the **RunEn/stop** bit will be cleared with the PA3 stop condition where as in **MSC** mode **RunEn** is not cleared.

Figure 29. CPU controlled Start PA[3] controlled Stop

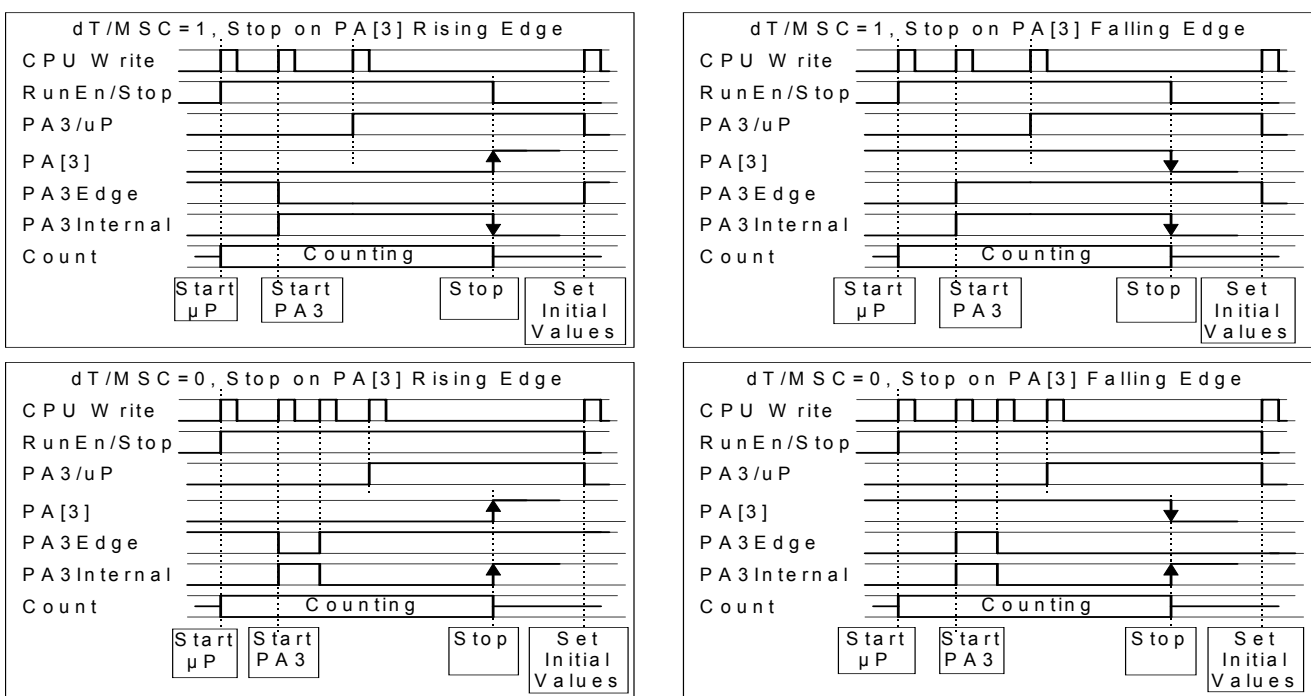

- **Pulse-width measurement of PA[3] Input Signals.**

In this mode the bit **dT/MSC=1** and **PA3/uP=1**. Setting **RunEn/stop=1** enables the operation. The first positive edge on PA3Internal signal will start the counter, the following negative edge will stop the counter end set bit **RunEn/Stop** to 0. PA3internal signal is a copy of the PA[3] terminal status if **PA3Edge=1**. with **PA3Edge=0** PA3Internal has the inverted PA[3] value. See also Figure 27 and Figure 30.

- **Port A PA[3] controlled Start and Stop Mode.**

In this mode the bit **dT/MSC=0** and **PA3/uP=1**. Setting **RunEn/stop=1** enables the operation. The first positive edge on PA3Internal signal will start the counter, the second edge will stop the counter, the third one will restart, etc.,. PA3internal signal is a copy of the PA[3] terminal status if **PA3Edge=1**. With **PA3Edge=0** PA3Internal has the inverted PA[3] value. See also Figure 27 and Figure 30.

Figure 30. dT/MSC behavior

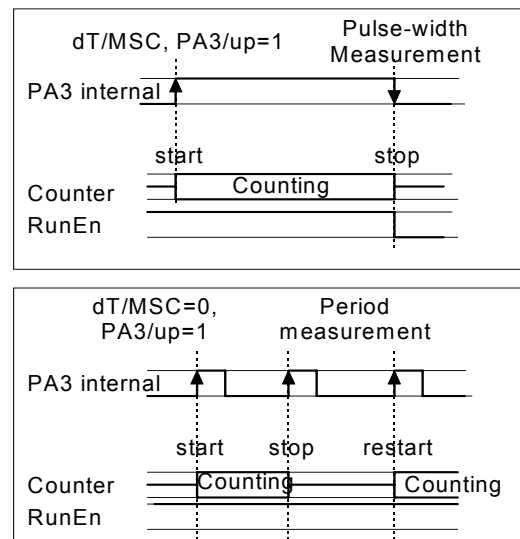

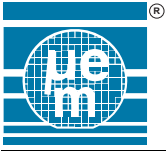

9.5 Millisecond Counter Registers

Table 9.5.1 Register RegMSCnt1

Bit	Name	Reset	R/W	Description
3	RunEn/Stop	0	R/W	Enable counter
2	PA3/μP	0	R/W	Port A or CPU start stop control
1	dT/MSC	0	R/W	Pulse-width measurement
0	ResMSC	0	R/W	Reset if write of 1 Read value is always 0

Default: Stop, CPU controlled.

Table 9.5.2 Register RegMSCnt2

Bit	Name	Reset	R/W	Description
3	DebFreqSel	0	R/W	Debouncer frequency select
2	PA3Edge	0	R/W	PA[3] edge selection
1	IntSel	0	R/W	Interrupt source selection
0	FIsec	0	R	Seconds flag

Default: Ck[14] is debouncer clock, negative edge, 1/10 Sec Interrupt requests

Table 9.5.3 Register RegMSCDataL

Bit	Name	Reset	R/W	Description
3	BCD[3]	0	R	1/1000 Seconds BCD value 3
2	BCD[2]	0	R	1/1000 Seconds BCD value 2
1	BCD[1]	0	R	1/1000 Seconds BCD value 1
0	BCD[0]	0	R	1/1000 Seconds BCD value 0

Table 9.5.4 Register RegMSCDataM

Bit	Name	Reset	R/W	Description
3	BCD[7]	0	R	1/100 Seconds BCD value 3
2	BCD[6]	0	R	1/100 Seconds BCD value 2
1	BCD[5]	0	R	1/100 Seconds BCD value 1
0	BCD[4]	0	R	1/100 Seconds BCD value 0

Table 9.5.5 Register RegMSCDataH

Bit	Name	Reset	R/W	Description
3	BCD[11]	0	R	1/10 Seconds BCD value 3
2	BCD[10]	0	R	1/10 Seconds BCD value 2
1	BCD[9]	0	R	1/10 Seconds BCD value 1
0	BCD[8]	0	R	1/10 Seconds BCD value 0

10 Interrupt Controller

The EM6521 has 12 different interrupt request sources, each of which is maskable. Five of them come from external sources and seven from internal sources.

External(4)	<ul style="list-style-type: none"> - Port A, - Serial Interface 	PA[3] .. PA[0] inputs
Internal(8)	<ul style="list-style-type: none"> - Prescaler - Melody timer - Serial Interface - Millisecond-Counter - 10-bit Counter 	Ck[1], Blink, 32Hz/8Hz 1/10Sec or 1Sec Count0, CountComp

To be able to send an interrupt to the CPU, at least one of the interrupt request flags must '1' (**IRQxx**) and the general interrupt enable bit **IntEn** located in the register **RegSysCntl1** must be set to 1. The interrupt request flags can only be set high by a positive edge on the **IRQxx** data flip-flop while the corresponding mask register bit (**MaskIRQxx**) is set to 1.

Figure 31. Interrupt Controller Block Diagram

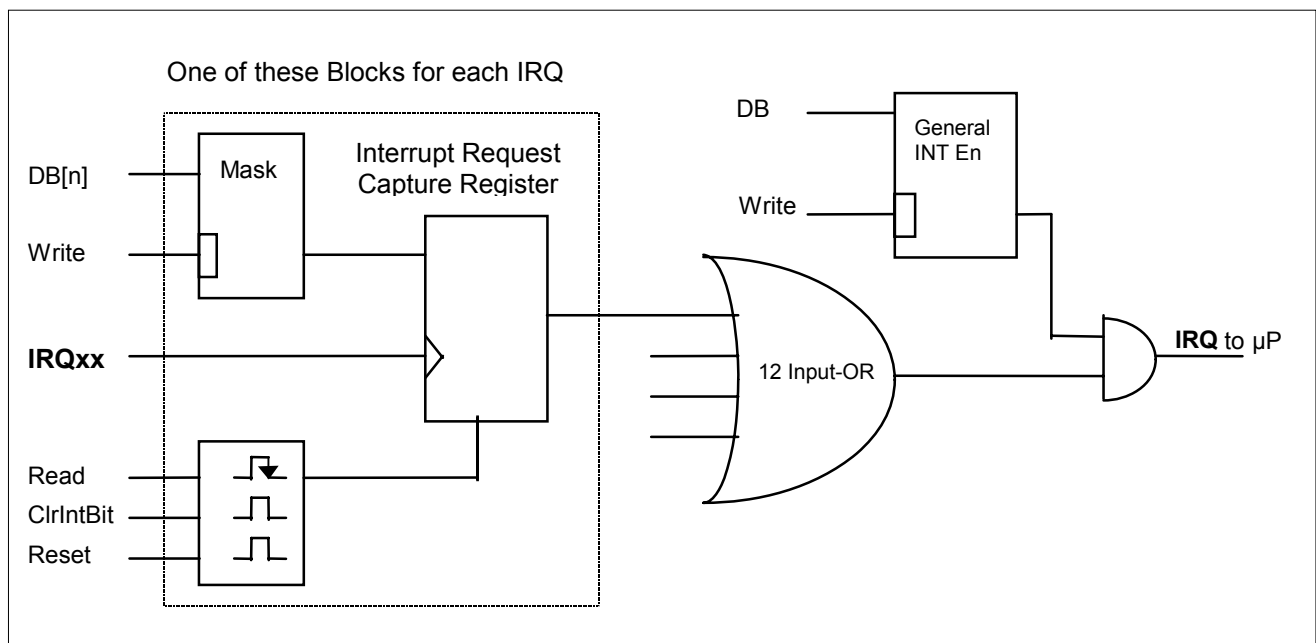

At power on or after any reset all interrupt request mask registers are cleared and therefore do not allow any interrupt request to be stored. Also the general interrupt enable **IntEn** is set to 0 (No IRQ to CPU) by reset.

After each read operation on the interrupt request registers **RegIRQ1**, **RegIRQ2** or **RegIRQ3** the contents of the addressed register are reset. Therefore one has to make a copy of the interrupt request register if there was more than one interrupt to treat. Each interrupt request flag may also be reset individually by writing 1 into it.

Interrupt handling priority must be resolved through software by deciding which register and which flag inside the register need to be serviced first.

Since the CPU has only one interrupt subroutine and the **IRQxx** registers are cleared after reading, the CPU does not miss any interrupt request which comes during the interrupt service routine. If any occurs during this time a new interrupt will be generated as soon as the software comes out of the current interrupt subroutine.



Any interrupt request sent by a periphery cell while the corresponding mask is not set will not be stored in the interrupt request register. All interrupt requests are stored in their **IRQxx** registers depending only on their mask setting and not on the general interrupt enable status.

Whenever the EM6521 goes into halt mode the **IntEn** bit is automatically set to 1, thus allowing to resume from halt mode with an interrupt.

10.1 Interrupt Control Registers

Table 10.1.6 Register RegIRQ1

Bit	Name	Reset	R/W	Description
3	IRQPA[3]	0	R *	Port A PA[3] interrupt request
2	IRQPA[2]	0	R *	Port A PA[2] interrupt request
1	IRQPA[1]	0	R *	Port A PA[1] interrupt request
0	IRQPA[0]	0	R *	Port A PA[0] interrupt request

*; Writing of 1 clears the corresponding bit.

Table 10.1.7 Register RegIRQ2

Bit	Name	Reset	R/W	Description
3	IRQHz1	0	R *	Prescaler interrupt request
2	IRQHz32/8	0	R *	Prescaler interrupt request
1	IRQBlink	0	R *	Prescaler interrupt request
0	IRQBz	0	R *	Melody timer interrupt request

*; Writing of 1 clears the corresponding bit.

Table 10.1.8 Register RegIRQ3

Bit	Name	Reset	R/W	Description
3	IRQSerial	0	R *	Serial interrupt request
2	IRQMSC	0	R *	Millisecond counter int. request
1	IRQCount0	0	R *	Counter interrupt request
0	IRQCntComp	0	R *	Counter interrupt request

*; Writing of 1 clears the corresponding bit.

Table 10.1.9 Register RegIRQMask1

Bit	Name	Reset	R/W	Description
3	MaskIRQPA[3]	0	R/W	Port A PA[3] interrupt mask
2	MaskIRQPA[2]	0	R/W	Port A PA[2] interrupt mask
1	MaskIRQPA[1]	0	R/W	Port A PA[1] interrupt mask
0	MaskIRQPA[0]	0	R/W	Port A PA[0] interrupt mask

Interrupt is not stored if the mask bit is 0.

Table 10.1.10 Register RegIRQMask2

Bit	Name	Reset	R/W	Description
3	MaskIRQHz1	0	R/W	Prescaler interrupt mask
2	MaskIRQHz32/8	0	R/W	Prescaler interrupt mask
1	MaskIRQBlink	0	R/W	Prescaler interrupt mask
0	MaskIRQBz	0	R/W	Melody timer interrupt mask

Interrupt is not stored if the mask bit is 0.

Table 10.1.11 Register RegIRQMask3

Bit	Name	Reset	R/W	Description
3	MaskIRQSerial	0	R/W	Serial interrupt mask
2	MaskIRQMSC	0	R/W	Millisecond counter int. mask
1	MaskIRQCount0	0	R/W	Counter interrupt mask
0	MaskIRQCntComp	0	R/W	Counter interrupt mask

Interrupt is not stored if the mask bit is 0

11 Supply Voltage Level Detector

The EM6521 has a built-in Supply Voltage Level Detector (SVLD) circuitry, such that the CPU can compare the supply voltage against a pre-selected value. During sleep mode this function is inhibited.

The CPU activates the supply voltage level detector by writing **VldStart** = 1 in the register **RegVldCntl**. The actual measurement starts on the next Ck[9] rising edge and lasts during the Ck[9] high period (2 ms at 32 KHz). The busy flag **VldBusy** stays high from **VldStart** set until the measurement is finished. The worst case time until the result is available is 1.5 Ck[9] prescaler clock periods (32 KHz -> 6 ms). The detection level must be defined in register **RegVldLevel** before the **VldStart** bit is set.

During the actual measurement (2 ms) the device will draw an additional 5 μA of $I_{V_{DD}}$ current. After the end of the measure the result is available by inspection of the bit **VldResult**. If the result is read 0, then the power supply voltage was greater than the detection level value. If read 1, the power supply voltage was lower than the detection level value. During each read while **Busy=1** the **VldResult** is not guaranteed. For compatibility reasons the SVLD levels available on the EM6521 are kept the same as the levels used on the EM6621. This means that all levels which may be lower 2.0V could not be reached anymore because they are below V_{DD} min.

Figure 32. SVLD Timing Diagram

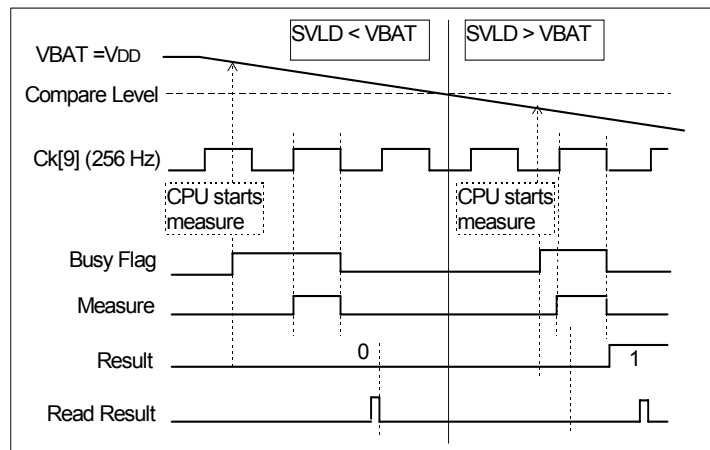

11.1 SVLD Register

Table 11.1.1 Register RegVldCntl

Bit	Name	Reset	R/W	Description
3	VldResult	0	R*	Vld result flag
2	VldStart	0	W	Vld start
2	VldBusy	0	R	Vld busy flag
1	NoOscWD	0	R/W	No Oscillator watchdog
0	NoLogicWD	0	R/W	No logic watchdog

R*; Read value while VLDBusy=1 is not guaranteed.

Table 11.1.2 Register RegVldLevel (Detection Level Value)

Bit	Name	Reset	R/W	Description
3	--	x	--	not active
2	VldLevel2	0	R/W	Vld level selection
1	VldLevel1	0	R/W	Vld level selection
0	VldLevel0	0	R/W	Vld level selection

Table 11.1.3 Voltage Level Detector Value Selecting

	VldLevel2	VldLevel1	VldLevel0	Typical voltage level
Level1	0	0	0	4.00
Level2	0	0	1	2.95
Level3	0	1	0	2.35
Level4	0	1	1	1.95*1
Level5	1	0	0	1.70**2
Level6	1	0	1	1.45**2
Level7	1	1	0	1.30**2
Level8	1	1	1	1.20**2

*1 level which may not be reached anymore because it can be lower than V_{DD} min.

**2 levels which are too far below V_{DD} min to be reached. (Are here for software compatibility with EM6621).

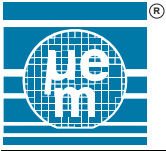

12 Strobe Output

The Strobe output is used to indicate either the EM6521 reset condition, a write operation on port B (WritePB) or the sleep mode. The selection is done in register **RegLcdCntl1**. Per default, the reset condition is output on the Strobe terminal.

For a port B write operation the strobe signal goes high for half a system clock period. Data can be latched on the falling edge of the strobe signal. This function is used to indicate when data on port B output terminals is changing.

The reset signal on the Strobe output is a copy of the internal CPU reset signal. The Strobe pin remains active high as long as the CPU gets the reset.

Both the reset condition and the port B write operation can be output simultaneously on the Strobe pin.

The strobe output select latches are reset by initial power on reset only.

Table 11.1.1. Strobe Output Selection

StrobeOutSel1	StrobeOutSel0	Strobe Terminal Output
0	0	System Reset
0	1	System Reset and WritePB
1	0	WritePB
1	1	Sleep

Figure 33 . Strobe Output

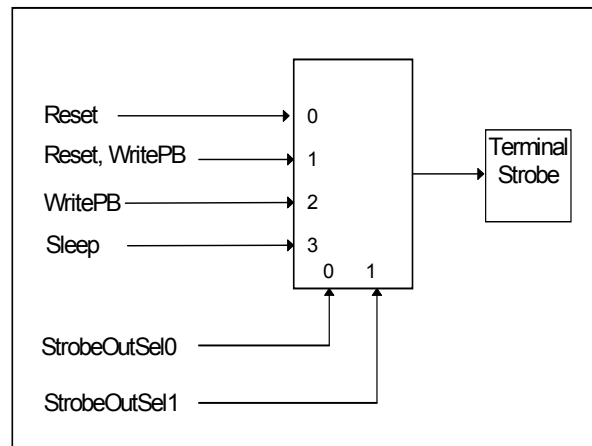

12.1 Strobe Register

Table 12.1.1 Register RegLDCnt1

Bit	Name	power on value	R/W	Description
3	StrobeOutSel1	0	R/W	Strobe output select
2	StrobeOutSel0	0	R/W	Strobe output select
1	<i>CkTripSel1</i>	0	R/W	<i>LCD multiplier clock select</i>
0	<i>CkTripSel0</i>	0	R/W	<i>LCD multiplier clock select</i>

The CKTripSel1, CKTripSel0 values are reset with every system reset.



13 RAM

The EM6521 has two 64x4 bit RAM's built-in.

The main RAM (RAM1) is direct addressable on addresses decimal(0 to 63). A second RAM (RAM2) is indirect addressable on addresses 64,65, 66 and 67 together with the index from RegIndexAdr.

Figure 34. Ram Architecture

64 x 4 direct addressable RAM1		64 x 4 indexed addressable RAM2		
RAM1_63	4 bit R/W	RAM2_3	RegIndexAdr[F]	4 bit R/W
RAM1_62	4 bit R/W		RegIndexAdr[E]	4 bit R/W
RAM1_61	4 bit R/W	
RAM1_60	4 bit R/W		RegIndexAdr[1]	4 bit R/W
.	.	RAM2_2	RegIndexAdr[0]	4 bit R/W
		
			RegIndexAdr[F]	4 bit R/W
			RegIndexAdr[E]	4 bit R/W
.	.	RAM2_1
			RegIndexAdr[1]	4 bit R/W
			RegIndexAdr[0]	4 bit R/W
			RegIndexAdr[F]	4 bit R/W
RAM1_3	4 bit R/W	RAM2_0	RegIndexAdr[E]	4 bit R/W
		
			RegIndexAdr[1]	4 bit R/W
			RegIndexAdr[0]	4 bit R/W
RAM1_2	4 bit R/W			
RAM1_1	4 bit R/W			
RAM1_0	4 bit R/W			

The RAM2 addressing is indirect using the **RegIndexAdr** value as an offset to the directly addressed base **RAM2_0, RAM2_1, RAM2_2 or RAM2_3** registers.

To write or read the RAM2 the user has first to set the offset value in the **RegIndexAdr** register. The actual access then is made on the RAM2 base addresses **RAM2_0, RAM2_1, RAM2_2 or RAM2_3**. Refer to Figure 34. Ram Architecture, for the address mapping.

i.e. Writing hex(5) to Ram2 add location 30: First write hex(E) to RegIndexAdr, then write hex(5) to RAM2_1

RAM Extension : Unused R/W Registers can often be used as possible RAM extension. Be careful not to use register which start, stop, or reset some functions. Unused LCD register latches can also be used as RAM memory.

In case of 3 times multiplex and using all the 20 Segment outputs you may have five additional 4 bit registers.. Also for each unused Segment output you may have one additional 4 bit register.

14 LCD Driver

The EM6521 has a built-in Liquid Crystal Display (LCD) driver. A maximum of 80 Segments can be displayed using the 20 Segment driver outputs (SEG[20:1]) in 4:1 multiplex, 60 Segments in the case of 3:1 multiplex, and the 4 back-planes (COM[4:1]).

The LCD driver has its own voltage regulator (1.05 Volt) and voltage multiplier to generate the driver bias voltages VL1, VL2 and VL3 (VLCD). Using the metal1 mask (ROM version only) the user can choose higher LCD reference voltages. Please check with EM Marin the possible values and their impact on power consumption.

The special architecture of this LCD driver allows the user to freely specify the data and address for each individual Segment using the interconnect metal2 mask (ROM version only) . It therefore adapts to every possible LCD display with a maximum of 80 independent segments. The LCD clock frequency is 256Hz. Thus the frame frequency is 256/8 Hz if 4:1 multiplex, or 256/6 if 3:1 multiplex.

Figure 35. LCD Architecture

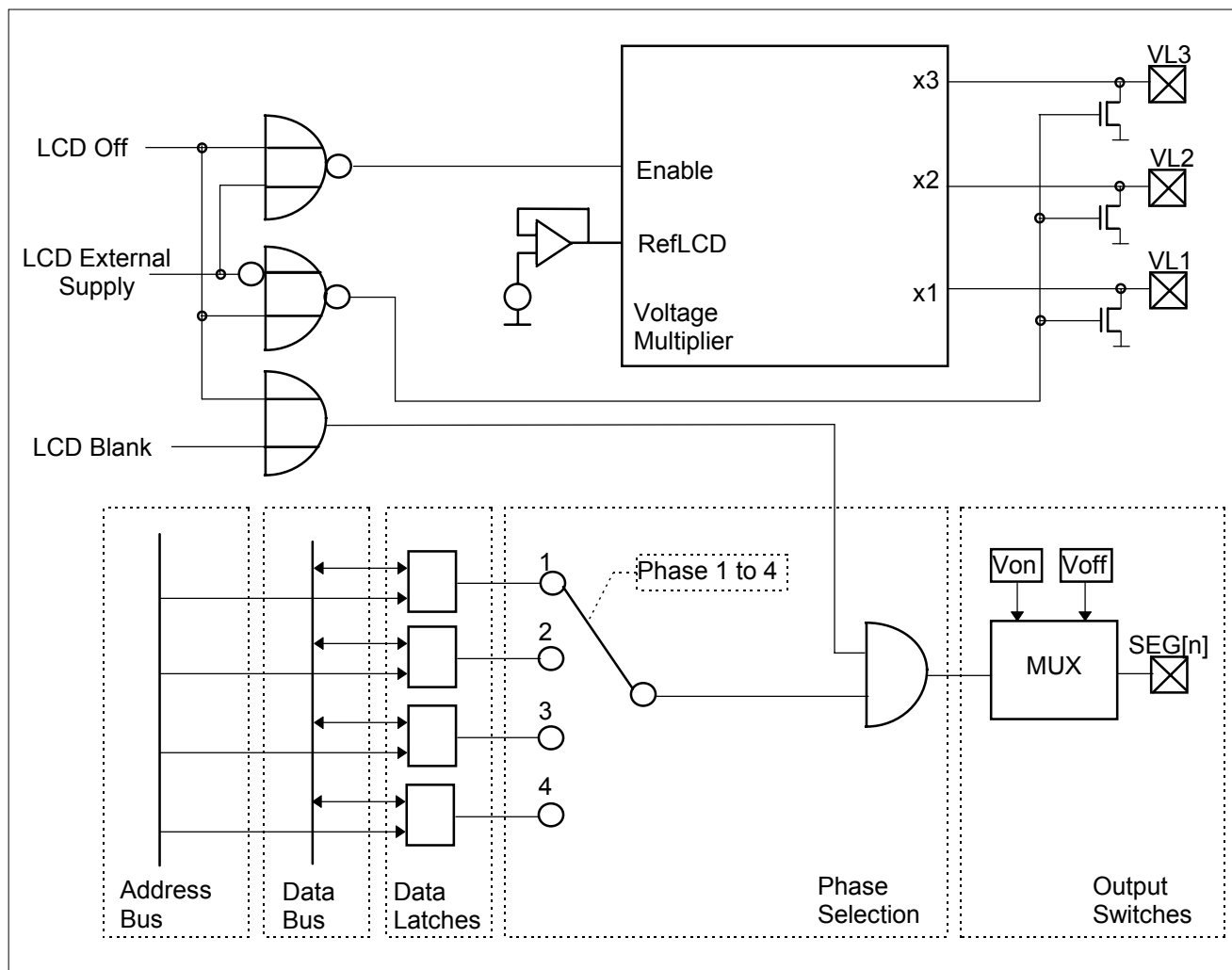



14.1 LCD Control

The LCD driver has two control registers **RegLCDCnt1**, **RegLCDCnt2** to optimize for display contrast, power consumption, operation mode and bias voltage source.

LCDExtSupply: Choosing external supply (**LCDExtSupply** =‘1’) disables the internal LCD voltage regulator and voltage multiplier, it also puts the bias voltage terminals VL1, VL2 and VL3 into high impedance state. External bias levels can now be connected to VL1, VL2 and VL3 terminals. (Resistor divider chain or others).

Another way to adapt the VL1, VL2 and VL3 levels to specific user needs is to overdrive the VL1 output (**LCDExtSupply** =0) with the desired value. The internal multiplier will multiply this new VL1 level to generate the corresponding levels VL2 and VL3. The bit **LCDExtSupply** is only reset by initial POR.

LCD4Mux: With this switch one selects either 3:1 or 4:1 (default) times multiplexing of the 20 Segment driver outputs. In the case of 3:1 multiplexing the COM[4] is off.

LCDOff: Disables the LCD. The voltage multiplier and regulator are switched off (0 current).The Segment latch information is maintained. The VL1,VL2 and VL3 outputs are pulled to V_{SS}.

LCDBlank: All Segment outputs are turned off. The voltage multiplier and regulator remain switched on.

LCDBlank can be used with the 1Hz and Blink interrupt to let the whole display blink (software controlled).

CkTripSel1,0: Selecting the appropriate voltage multiplier frequency to optimize display contrast and power consumption. The value to use is also depending on the selected multiplier booster capacitors (typically 100nF).

14.2 LCD Addressing

The LCD driver addressing is indirect using the **RegIndexAdr** value as an offset to the directly addressed base **LCD_1**, **LCD_2** or **LCD_3** registers. All LCD Segment registers are R/W.

At address LCD_3 only the first 8 Index locations are usable. The Index locations hex(8 to F) are non implemented.

A total of 40 addresses are available to the user to freely define the addressing of the LCD Segment latches. For each of these latches the user may choose the address and data to be connected. See also section 14.3. However only 20x4 LCD Segment latches are implemented. The unused address locations are empty and can not be used as RAM.

Figure 36. LCD Address Mapping

40 x 4 Indexed Addressable LCD Latches but Maximum 20x4 Bits are R/W		
LCD_3	RegIndexAdr[8]	4 bit R/W
	RegIndexAdr[7]	4 bit R/W

	RegIndexAdr[1]	4 bit R/W
LCD_2	RegIndexAdr[0]	4 bit R/W
	RegIndexAdr[F]	4 bit R/W
	RegIndexAdr[E]	4 bit R/W

LCD_1	RegIndexAdr[1]	4 bit R/W
	RegIndexAdr[0]	4 bit R/W

	RegIndexAdr[F]	4 bit R/W
LCD_1	RegIndexAdr[E]	4 bit R/W

	RegIndexAdr[1]	4 bit R/W
	RegIndexAdr[0]	4 bit R/W



14.3 Free Segment Allocation

Each Segment (SEG[20:1]) terminal outputs the time multiplexed information from its 4 Segment data latches. Information stored in latch 1 is output during phase1, latch 2 during phase 2, latch 3 during phase 3 and latch 4 during phase 4. In the case of 3 to 1 multiplexing the phase 4 and the latch 4 are not used. This phase information on the segment outputs together with the common outputs (COM[4:1]) - also called back-planes - defines if a given LCD segment is light or not. COM[1] is on during phase 1 and off during phase 2,3,4, COM[2] is on during phase 2 and off during phase 1,3,4, etc.

For each segment data latch the address location within the LCD address spacing (**LCD_3 + Index(8), LCD_2 + Index(16), LCD_1 + Index(16) --> LCDAdr[39:0]**) can be user defined.

For each segment data latch the data bus connection (DB[3:0]) can be user defined.

Table 14.3.1 Default LCD Configuration used on EM6521

Segment outputs	COM[1] = phase1	COM[2] = phase2	COM[3] = phase3	COM[4] = phase4
SEG[1]	DB[0], LCDAdr[0]	DB[1], LCDAdr[0]	DB[2], LCDAdr[0]	DB[3], LCDAdr[0]
SEG[2]	DB[0], LCDAdr[1]	DB[1], LCDAdr[1]	DB[2], LCDAdr[1]	DB[3], LCDAdr[1]
SEG[3]	DB[0], LCDAdr[2]	DB[1], LCDAdr[2]	DB[2], LCDAdr[2]	DB[3], LCDAdr[2]
...
SEG[18]	DB[0], LCDAdr[18]	DB[1], LCDAdr[18]	DB[2], LCDAdr[18]	DB[3], LCDAdr[18]
SEG[19]	DB[0], LCDAdr[19]	DB[1], LCDAdr[19]	DB[2], LCDAdr[19]	DB[3], LCDAdr[19]
SEG[20]	DB[0], LCDAdr[20]	DB[1], LCDAdr[20]	DB[2], LCDAdr[20]	DB[3], LCDAdr[20]

14.4 LCD Registers

Table 14.4.1 Register RegLcdCntl1

Bit	Name	Reset	R/W	Description
3	StrobeOutSel1	POR to '0'	R/W	Strobe output select
2	StrobeOutSel0	POR to '0'	R/W	Strobe output select
1	CkTripSel1	0	R/W	LCD multiplier clock select
0	CkTripSel0	0	R/W	LCD multiplier clock select

StrobeOutSel1,0 is reset by initial power on only.

Table 14.4.2 Multiplier Clock Frequency Select

CkTripSel0	CkTripSel1	Multiplier Clock	on 32 KHz operation
0	0	Ck[10]	512 Hz
1	0	Ck[9]	256 Hz
0	1	Ck[8]	128 Hz
1	1	Ck[7]	64 Hz

Table 14.4.3 Register LcdCntl2

Bit	Name	Reset	R/W	Description
3	LCDBlank	1	R/W	LCD Segment outputs off
2	LCDOff	1	R/W	LCD off (multiplier off)
1	LCD4Mux	1	R/W	4 : 1 multiplexed
0	LCDExtSupply	POR to '0'	R/W	External supply for VL1, VL2 and VL3

LCDExtSupply is reset to '0' by POR only.



Figure 37 LCD Multiplexing Waveform

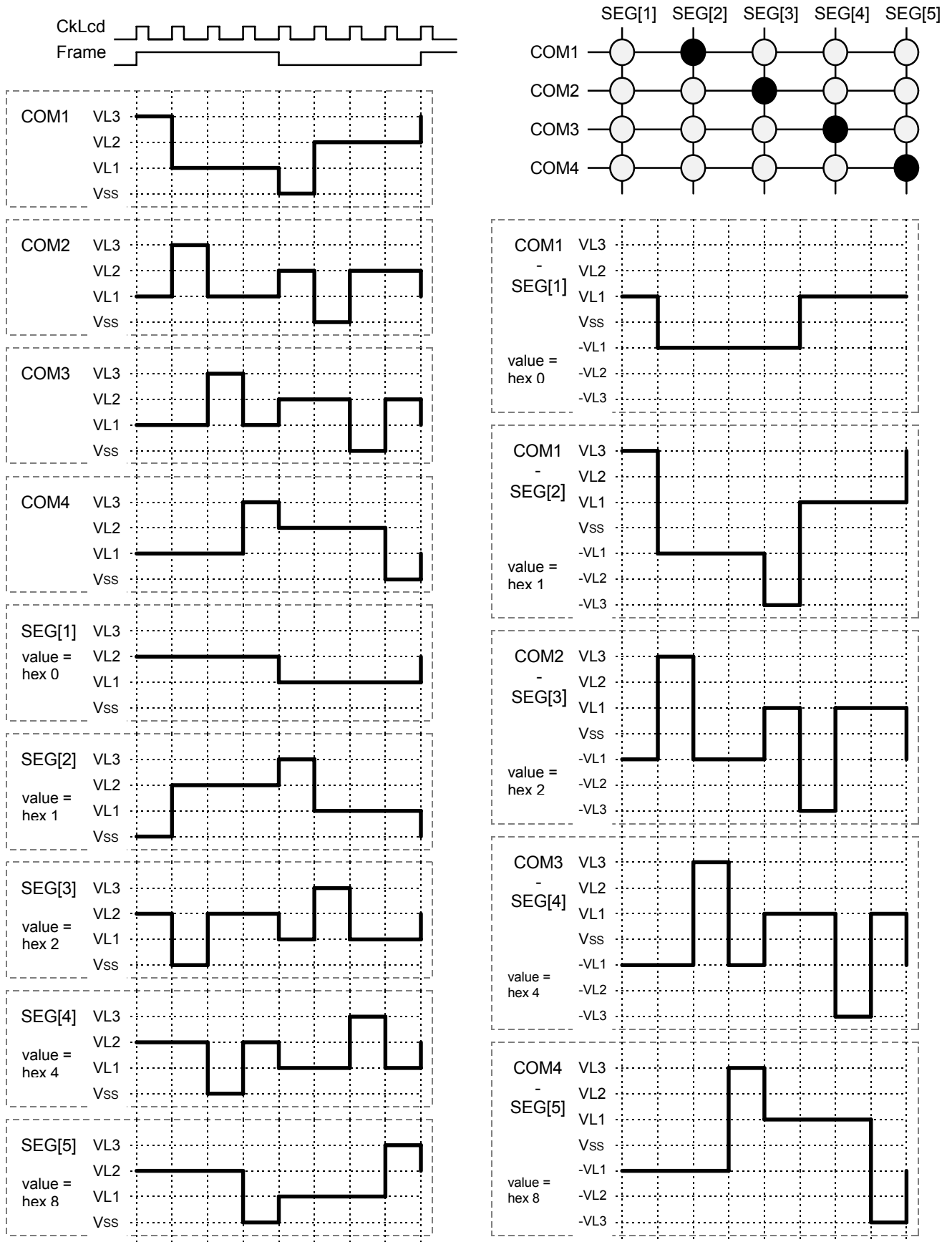

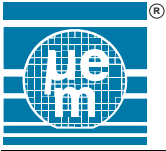

15 Peripheral Memory Map

Reset values are valid after power up or after every system reset.

Register Name	Add Hex	Add Dec.	Reset Value	Read Bits	Write Bits	Remarks
			b'3210	Read / Write Bits		
Ram1_0	00	0	xxxx	0: Data0 1: Data1 2: Data2 3: Data3		Normal addressable Ram 64x4 bit
...
Ram1_63	3F	63	xxxx	0: Data0 1: Data1 2: Data2 3: Data3		Normal addressable Ram 64x4 bit
Ram2_0	40	64	xxxx	0: Data0 1: Data1 2: Data2 3: Data3		16 nibbles addressable over index register on add 'H70
...			
Ram2_3	43	67	xxxx	0: Data0 1: Data1 2: Data2 3: Data3		16 nibbles addressable over index register on add 'H70
LCD_1	44	68	xxxx	Connections are user definable. See LCD section		16 nibbles addressable over index register on add 'H70
LCD_2	45	69	xxxx	Connections are user definable. See LCD section		16 nibbles addressable over index register on add 'H70
LCD_3	46	70	xxxx	Connections are user definable. See LCD section		The 8 lower nibbles are addressable over the index register on add 'H70. The 8 higher Nibbles are not used and not implemented
---	47	71				Reserved, not implemented
---
---	4F	79				Reserved, not implemented
RegPA	50	80	xxxx	0: PAData[0] 1: PAData[1] 2: PAData[2] 3: PAData[3]	----	Read port A directly
RegPBCntl	51	81	0000	0: PBIOCntl[0] 1: PBIOCntl[1] 2: PBIOCntl[2] 3: PBIOCntl[3]		Port B control Default: input mode



EM6521

Register Name	Add Hex	Add Dec.	Reset Value b'3210	Read Bits	Write Bits	Remarks
				Read / Write Bits		
RegPBData	52	82	0000	0: PB[0] 1: PB[1] 2: PB[2] 3: PB[3]	0: PBData[0] 1: PBData[1] 2: PBData[2] 3: PBData[3]	Port B data output Pin port B read Default : 0
RegSCnt1	53	83	0000	0: MSBnLSB 1: POSnNeg 2: MS0 3: MS1		Serial interface control 1
RegSCnt2	54	84	0000	0: OM[0] 1: OM[1] 2: Status 3: Start		Serial interface control 2
RegSDataL	55	85	0000	0: SerDataL[0] 1: SerDataL[1] 2: SerDataL[2] 3: SerDataL[3]		Serial interface low data nibble
RegSDataH	56	86	0000	0: SerDataH[0] 1: SerDataH[1] 2: SerDataH[2] 3: SerDataH[3]		Serial interface high data nibble
RegSPData	57	87	0000	0: PSP[0] 1: PSP[1] 2: PSP[2] 3: PSP[3]	0: SerPData[0] 1: SerPData[1] 2: SerPData[2] 3: SerPData[3]	Serial interface parallel data out
RegMeIFSel	58	88	0000	0: MeIFSel[0] 1: MeIFSel[1] 2: MeIFSel[2] 3: BzOutEn		Melody frequency select and output enable control
RegMeITim	59	89	0000	0:FTimSel0 1:FTimSel1 2:Auto 3:FIBuzzer	0:FTimSel0 1:FTimSel1 2:Auto 3:SwBuzzer	Melody timer control
RegMeIPeri	5A	90	0000	0: - 1: - 2: - 3: -	0: Per[0] 1: Per[1] 2: Per[2] 3: Per[3]	Melody timer period
RegCCnt1	5B	91	0000	0: CountFSel0 1: CountFSel1 2: CountFSel2 3: UP/Down		10-bit counter control 1; frequency and up/down
RegCCnt2	5C	92	0000	0: '0' 1: EnComp 2: EvCount 3: Start	0: Load 1: EnComp 2: EvCount 3: Start	10-bit counter control 2; comparison, event counter and start
RegCDataL	5D	93	0000	0: Count[0] 1: Count[1] 2: Count[2] 3: Count[3]	0: CReg[0] 1: CReg[1] 2: CReg[2] 3: CReg[3]	10-bit counter data low nibble
RegCDataM	5E	94	0000	0: Count[4] 1: Count[5] 2: Count[6] 3: Count[7]	0: CReg[4] 1: CReg[5] 2: CReg[6] 3: CReg[7]	10-bit counter data middle nibble
RegCDataH	5F	95	0000	0: Count[8] 1: Count[9] 2: BitSel[0] 3: BitSel[1]	0: CReg[8] 1: CReg[9] 2: BitSel[0] 3: BitSel[1]	10 bit counter data high bits

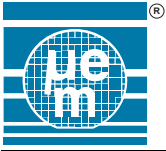

EM6521

Register Name	Add Hex	Add Dec.	Reset Value b'3210	Read Bits	Write Bits	Remarks
				Read / Write Bits		
RegMSCCnt1	60	96	0000	0: '0' 1: dT/MSC 2: PA3/μP 3: RunEn/Stop	0: ResMSC 1: dT/MSC 2: PA3/μP 3: RunEn/Stop	millisecond counter control register 1; reset, delta time, control source
RegMSCCnt2	61	97	0000	0: FISec 1: IntSel 2: PA3Edge 3: DebFreqSel	0: -- 1: IntSel 2: PA3Edge 3: DebFreqSel	Millisecond counter control register 2; 1 sec flag, Interrupt and PA3 edge select
RegMSCDataL	62	98	0000	0: BCD[0] 1: BCD[1] 2: BCD[2] 3: BCD[3]	0: - 1: - 2: - 3: -	Millisecond counter; binary coded decimal value, low nibble
RegMSCDataM	63	99	0000	0: BCD[4] 1: BCD[5] 2: BCD[6] 3: BCD[7]	0: - 1: - 2: - 3: -	Millisecond counter; binary coded decimal value, middle nibble
RegMSCDataH	64	100	0000	0: BCD[8] 1: BCD[9] 2: BCD[10] 3: BCD[11]	0: - 1: - 2: - 3: -	Millisecond counter; binary coded decimal value, high nibble
RegIRQMask1	65	101	0000	0: MaskIRQPA[0] 1: MaskIRQPA[1] 2: MaskIRQPA[2] 3: MaskIRQPA[3]		Port A interrupt mask; masking active 0
RegIRQMask2	66	102	0000	0: MaskIRQBz 1: MaskIRQBlink 2: MaskIRQHz32/8 3: MaskIRQHz1		Buzzer and prescaler interrupt mask; masking active low
RegIRQMask3	67	103	0000	0: MaskIRQCntComp 1: MaskIRQCount0 2: MaskIRQMSC 3: MaskIRQSerial		10-bit counter, millisecond counter, serial interrupt mask masking active low
RegIRQ1	68	104	0000	0: IRQPA[0] 1: IRQPA[1] 2: IRQPA[2] 3: IRQPA[3]	0: RIRQPA[0] 1: RIRQPA[1] 2: RIRQPA[2] 3: RIRQPA[3]	Read: port A interrupt Write: Reset IRQ if data bit = 1.
REgIRQ2	69	105	0000	0: IRQBz 1: IRQBlink 2: IRQHz32/8 3: IRQHz1	0: RIRQBz 1: RIRQBlink 2: RIRQHz32/8 3: RIRQHz1	Read: buzzer and prescaler IRQ ; Write: Reset IRQ id data bit = 1
RegIRQ3	6A	106	0000	0: IRQCntComp 1: IRQCount0 2: IRQMSC 3: IRQSerial	0: RIRQCntComp 1: RIRQCount0 2: RIRQMSC 3: RIRQSerial	Read: 10-bit counter, millisecond counter, serial interrupt Write: Reset IRQ if data bit = 1.
RegSysCnt1	6B	107	0000	0: ChTmDis 1: SellntFull 2: '0' 3: IntEn	0: ChTmDis 1: SellntFull 2: Sleep 3: IntEn	System control 1 <i>ChTmDis only usable only for EM test modes with Test=1</i>
RegSysCnt2	6C	108	0p00 p = POR	0: WDVa10 1: WDVa11 2: SleepEn 3: '0'	0: -- 1: -- 2: SleepEn 3: WDRreset	System control 2; watchdog value and periodical reset, enable sleep mode

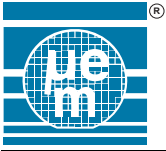

EM6521

Register Name	Add Hex	Add Dec.	Reset Value	Read Bits	Write Bits	Remarks
			b'3210	Read / Write Bits		
RegPresc	6D	109	0000	0: DebSel 1: PrIntSel 2: '0' 3: PWMOn	0: DebSel 1: PrIntSel 2: ResPresc 3: PWMOn	Prescaler control; debouncer and prescaler interrupt select
IXLow	6E	110	xxxx	0: IXLow[0] 1: IXLow[1] 2: IXLow[2] 3: IXLow[3]		Internal μ P index register low nibble; for μ P indexed addressing
IXHigh	6F	111	xxxx	0: IXHigh[4] 1: IXHigh[5] 2: IXHigh[6] 3: '0'	0: IXHigh[4] 1: IXHigh[5] 2: IXHigh[6] 3: --	Internal μ P index register high nibble; for μ P indexed addressing
RegIndexAdr	70	112	0000	0: IndexAdr[0] 1: IndexAdr[1] 2: IndexAdr[2] 3: IndexAdr[3]		Indexed addressing register for 4x16 nibble RAM2 and 3x16 + 8 nibble LCD
RegLDCnt1	71	113	PP00	0: CkTripSel0 1: CkTripSel1 2: StrobeOutSel0 3: StrobeOutSel1		LCD control 0; multiplier clock and strobe output select
RegLDCnt2	72	114	111P	0: LCDExtSupply 1: Lcd4xMux 2: LCDOff 3: LCDBlank		LCD control 1; main selects
RegVldCntl	73	115	0000	0: NoLogicWD 1: NoOscWD 2: VldBusy 3: VldResult	0: NoLogicWD 1: NoOscWD 2: VldStart 3: --	Voltage level detector control
RegVldLevel	74	116	x000	0: VldLevel0 1: VldLevel1 2: VldLevel2 3: --		Voltage level detector; detection level selection

P = defined by POR (power on reset)

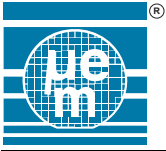

16 Option Register Memory Map

The values of the option registers are set by initial reset on power up and through write operations only. Other resets ; as reset from watchdog, reset from input port A, reset from pin RESET, etc. do not change the options register value.

Register Name	Add Hex	Add Dec.	Reset Value b'3210	Read Bits	Write Bits	Remarks
				Read / Write Bits		
OPTDebIntPA OPT[3:0]	75	117	0000	0: NoDebIntPA[0] 1: NoDebIntPA[1] 2: NoDebIntPA[2] 3: NoDebIntPA[3]		Debouncer on port A for interrupt gen. Default: debouncer on
OPTIntEdgPA OPT[7:4]	76	118	0000	0: IntEdgPA[0] 1: IntEdgPA[1] 2: IntEdgPA[2] 3: IntEdgPA[3]		Interrupt edge select on port A. Default: pos. edge
OPTNoPullPA OPT[11:8]	77	119	0000	0: NoPullPA[0] 1: NoPullPA[1] 2: NoPullPA[2] 3: NoPullPA[3]		Pull-down selection on port A Default: pull-down
OPTNoPdPB OPT[15:12]	78	120	0000	0: NoPdPB[0] 1: NoPdPB[1] 2: NoPdPB[2] 3: NoPdPB[3]		Pull-down selection on port B Default: pull-down
OPTNchOpDPB OPT[19:16]	79	121	0000	0: NchOpDPB[0] 1: NchOpDPB[1] 2: NchOpDPB[2] 3: NchOpDPB[3]		Nch. open drain output on port B Default: CMOS output
OPTNchOpDPS OPT[23:20]	7A	122	0000	0: NchOpDPS[0] 1: NchOpDPS[1] 2: NchOpDPS[2] 3: NchOpDPS[3]		Nch. open drain output on port serial Default: CMOS output
OPTFSelPB OPT[31:28]	7B	123	0000	0: PB1HzOut 1: PB1kHzOut 2: PB32kHzOut 3: InpResSleep		Frequency output on port B, reset from sleep mode with port A
OPTInpRsel1	7C	124	0000	0: InpRes1PA[0] 1: InpRes1PA[1] 2: InpRes1PA[2] 3: InpRes1PA[3]		Reset through port A inputs selection. Refer to reset part
OPTInpRsel2	7D	125	0000	0: InpRes2PA[0] 1: InpRes2PA[1] 2: InpRes2PA[2] 3: InpRes2PA[3]		Reset through port A inputs selection. Refer to reset part
OPTNoPdPS OPT[35:32]	7E	126	0000	0: NoPdPS[0] 1: NoPdPS[1] 2: NoPdPS[2] 3: NoPdPS[3]		No Pull-down on port SP Default: pull-down
<i>RegTestEM</i>	<i>7F</i>	<i>127</i>	<i>----</i>	<i>----</i>	<i>----</i>	<i>for EM test only;</i>

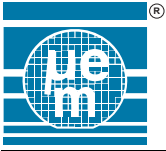

17 Active Supply Current Test

For this purpose, five instructions at the end of the ROM will be added.

```
Testloop: STI      00H, 0AH
           LDR      1BH
           NXORX
           JPZ      Testloop
           JMP      00H
```

To stay in the testloop, these values must be written in the corresponding addresses before jumping in the loop:

```
1BH:      0101b
32H:      1010b
6EH:      0010b
6FH:      0011b
```

Free space after last instruction: JMP 00H (0000)

Remark: empty space within the program are filled with NOP (FOFF).

18 Mask Options

Most options which in many μ Controllers are realized as metal mask options are directly user selectable with the option registers, therefore allowing a maximum freedom of choice. See chapter: Option Register Memory Map.

The following options can be selected at the time of programming the metal mask ROM, except the LCD Segment allocation which is defined using the interconnect metal2 mask. The EM6521 is delivered with the default metal mask settings. If you need other mask settings please contact EM Microelectronic Marin SA

18.1 Input / Output Ports

18.1.1 Port A Metal Options

(For ROM Version) Pull-up or no pull-up can be selected for each port A input. A pull-up selection is excluding a pull-down on the same input.

Pull-down (default) or no pull-down can be selected for each port A input. A pull-down selection is excluding a pull-up on the same input.

The total pull value (pull-up or pull-down) is a series resistance out of the resistance R1 and the switching transistor. The default resistor R1 value is 100 KOhm.

Figure 38. Port A Pull Options

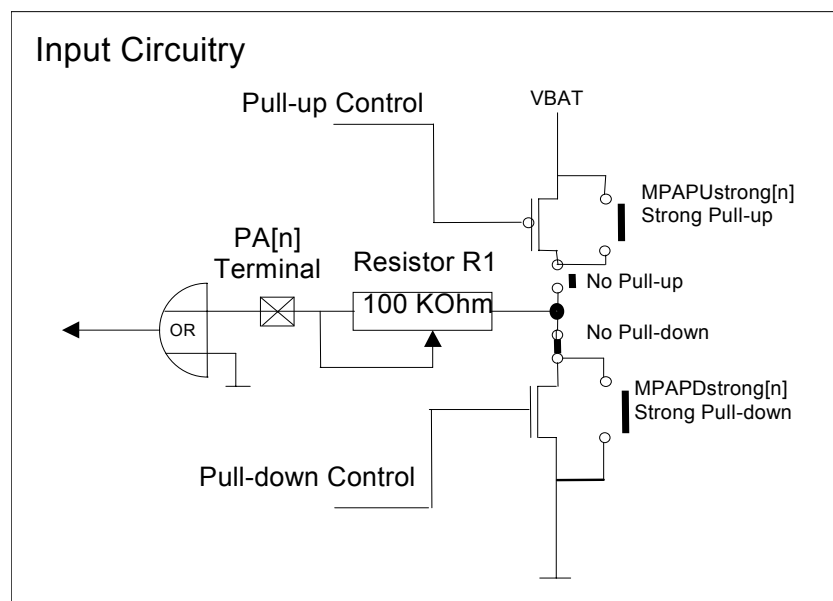

Option Name		Strong Pull-down	R1 Value Typ. 100k	No Pull-down
		1	3	4
MPAPD[3]	PA3 input pull-down	x	100k	
MPAPD[2]	PA2 input pull-down	x	100k	
MPAPD[1]	PA1 input pull-down	x	100k	
MPAPD[0]	PA0 input pull-down	x	100k	

To select an option put an **X** in column 1,2 and 4 and reconfirm the R1 value in column 3.

The default value is : Strong pull-down with R1=100 KOhm

Option Name		Strong Pull-up	R1 Value typ. 100k	No Pull-up
		1	3	4
MPAPU[3]	PA3 input pull-up		100k	x
MPAPU[2]	PA2 input pull-up		100k	x
MPAPU[1]	PA1 input pull-up		100k	x
MPAPU[0]	PA0 input pull-up		100k	x

To select an option put an **X** in column 1,2 and 4 and reconfirm the R1 value in column 3.

The default value is : No pull-up

18.1.2 Port B Metal Options

(For ROM Version) Pull-up or no pull-up can be selected for each port B input. The pull-up is only active in Nch. open drain mode. Pull-down or no pull-down can be selected for each port B input.

The total pull value (pull-up or pull-down) is a series resistance out of the resistance R1 and the switching transistor. The default resistor R1 value is 100 KOhm.

Figure 39. Port B Pull Options

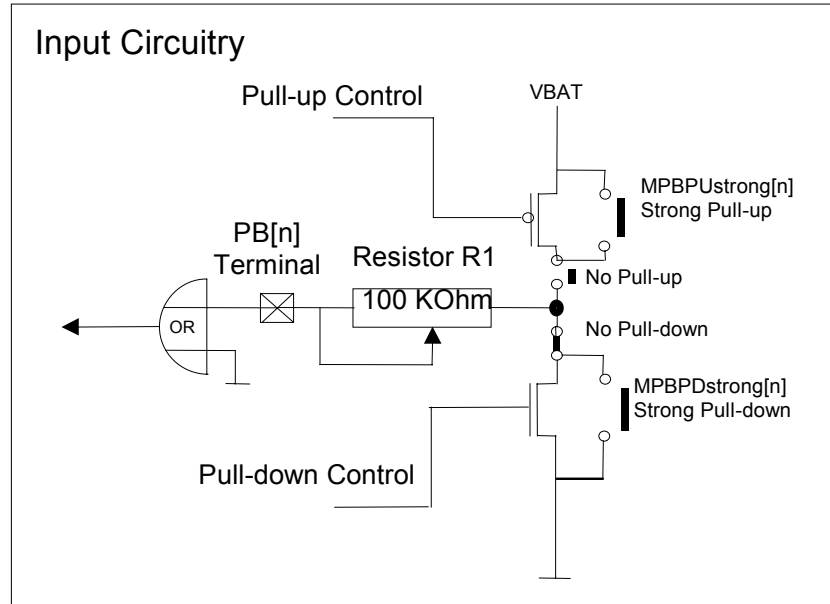

Option Name		Strong Pull-down	R1 Value Typ.100k	No Pull-down
		1	3	4
MPBPD[3]	PB3 input pull-down	x	100k	
MPBPD[2]	PB2 input pull-down	x	100k	
MPBPD[1]	PB1 input pull-down	x	100k	
MPBPD[0]	PB0 input pull-down	x	100k	

To select an option put an **X** in column 1,2 and 4 and reconfirm the R1 value in column 3.

The default value is : Strong pull-down with R1=100 KOhm

Option Name		Strong Pull-up	R1 value Typ. 100k	NO Pull-up
		1	3	4
MPBPU[3]	PB3 input pull-up	x	100k	
MPBPU[2]	PB2 input pull-up	x	100k	
MPBPU[1]	PB1 input pull-up	x	100k	
MPBPU[0]	PB0 input pull-up	x	100k	

To select an option put an **X** in column 1,2 and 4 and reconfirm the R1 value in column 3.

The default value is : Strong pull-up with R1=100 KOhm

18.1.3 Port SP Metal Options

(For ROM Version) Pull-up or no pull-up can be selected for each port SP input. The pull-up is only active in Nch. open drain mode. Pull-down or no pull-down can be selected for each port SP input.

The total pull value (pull-up or pull-down) is a series resistance out of the resistance R1 and the switching transistor. The default resistor R1 value is 100 KOhm.

Figure 40. Port SP Pull Options

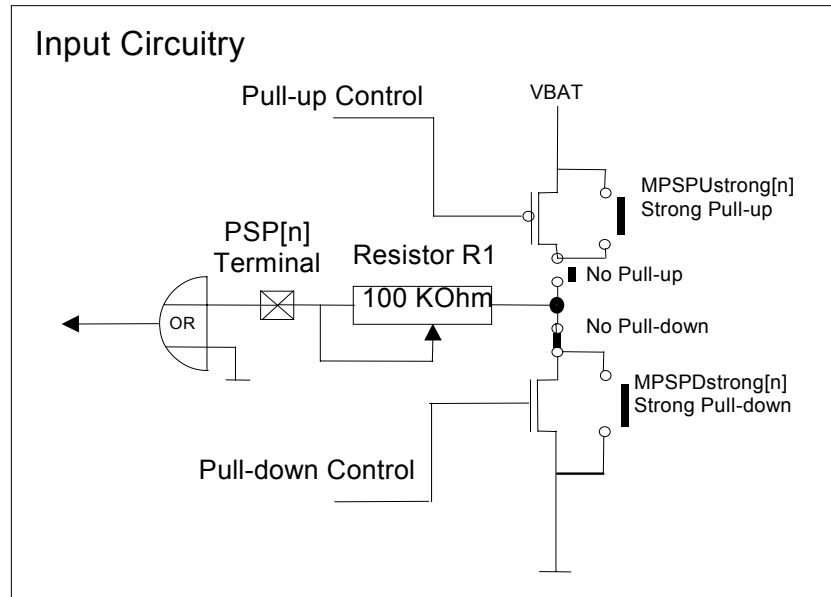

Option Name		Strong Pull-down	R1 Value Typ.100k	No Pull-down
		1	3	4
MPSPD[3]	PB3 input pull-down	x	100k	
MPSPD[2]	PB2 input pull-down	x	100k	
MPSPD[1]	PB1 input pull-down	x	100k	
MPSPD[0]	PB0 input pull-down	x	100k	

To select an option put an **X** in column 1,2 and 4 and reconfirm the R1 value in column 3.

The default value is : Strong pull-down with R1=100 KOhm

Option Name		Strong Pull-up	R1 value Typ. 100k	NO Pull-up
		1	3	4
MPSPU[3]	PB3 input pull-up	x	100k	
MPSPU[2]	PB2 input pull-up	x	100k	
MPBPU[1]	PB1 input pull-up	x	100k	
MPSPU[0]	PB0 input pull-up	x	100k	

To select an option put an **X** in column 1,2 and 4 and reconfirm the R1 value in column 3.

The default value is : Strong pull-up with R1=100 KOhm

18.1.4 Voltage Regulator Option

Option name		Default value	user value
		A	B
MVreg	Voltage Regulator	YES	

(For ROM Version) By default the internal voltage regulator supplies the core logic the RAM and the ROM. With option **MVreg(B)** the regulator is cut and V_{BAT} is supplying the core logic the ROM and the RAM.

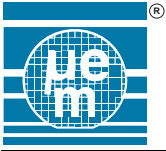

18.1.5 Debouncer Frequency Option

Option Name		Default Value	User Value
		A	B
MDeb	Debouncer freq.	Ck[11]	

(ROM version only) By default the debouncer frequency is Ck[11]. The user may choose Ck[14] instead of Ck[11].

Ck[14] corresponds to maximum 0.25ms debouncer time in case of a 32kHz oscillator.

18.1.6 User defined LCD Segment Allocation

(For ROM version) If using a different Segment allocation from the one described in chapter 14.3, one needs to fill in following table. The Segment allocation connection are realized with the interconnect Metal2 mask.

4 times MUX	COM[1]	COM[2]	COM[3]	COM[4]
3 times MUX	COM[1]	COM[2]	COM[3]	--
SEG[1]				
SEG[2]				
SEG[3]				
SEG[4]				
SEG[5]				
SEG[6]				
SEG[7]				
SEG[8]				
SEG[9]				
SEG[10]				
SEG[11]				
SEG[12]				
SEG[13]				
SEG[14]				
SEG[15]				
SEG[16]				
SEG[17]				
SEG[18]				
SEG[19]				
SEG[20]				

The customer should specify the required options at the time of ordering. A copy of the pages 57 to 60, as well as the « Software ROM characteristic file » generated by the assembler (*.STA) should be attached to the order.



19 Measured Electrical Behaviors

19.1 IDD Current

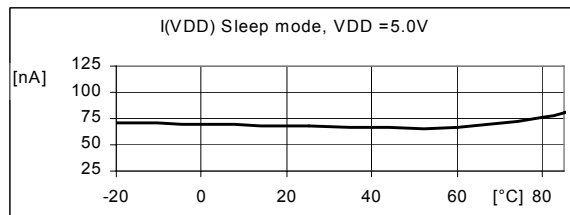
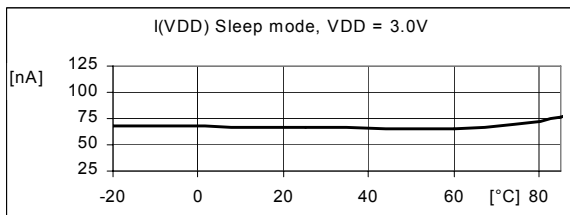
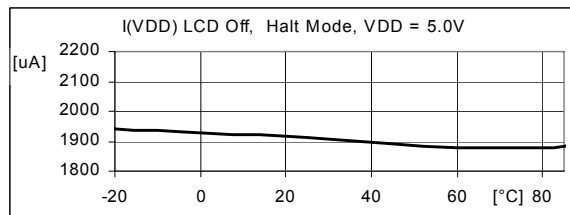
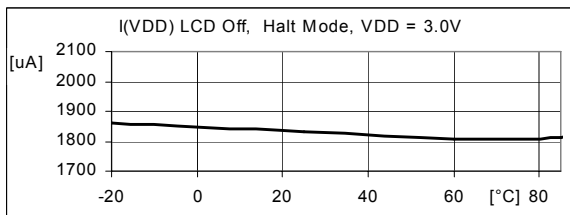
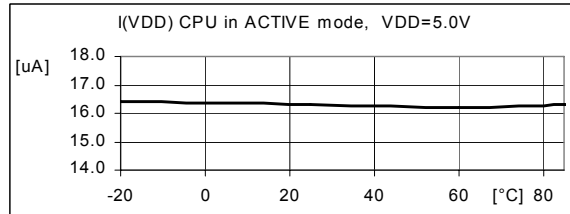
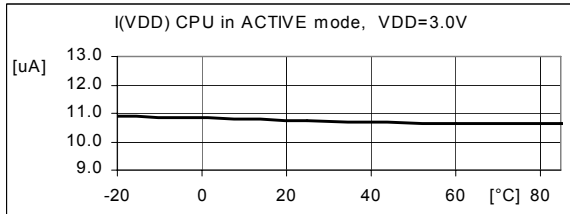

19.2 Regulator Voltage

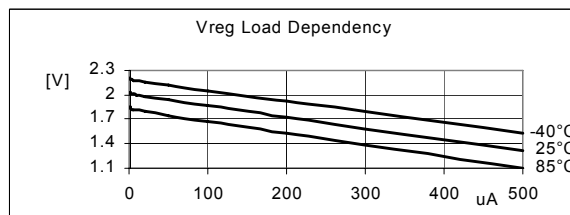
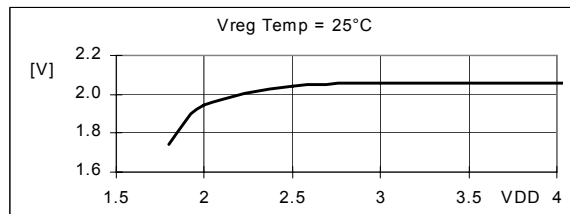
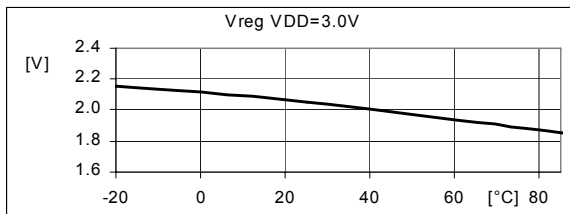

19.3 Pull Resistors

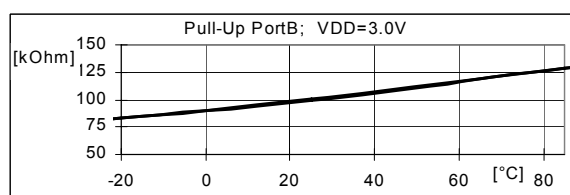
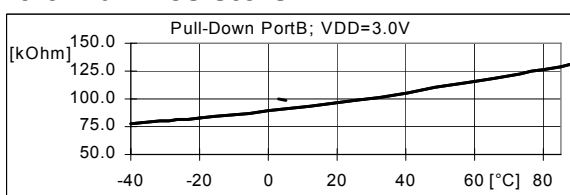



19.4 Output currents

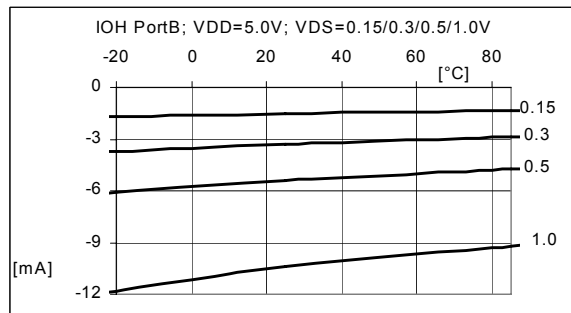
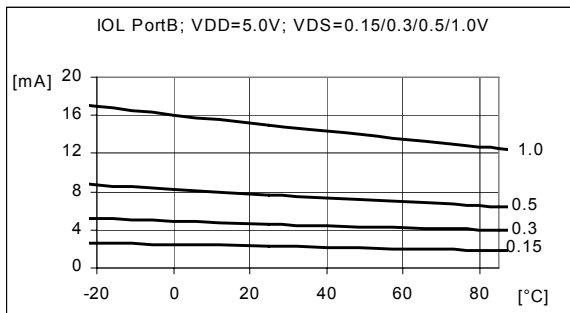
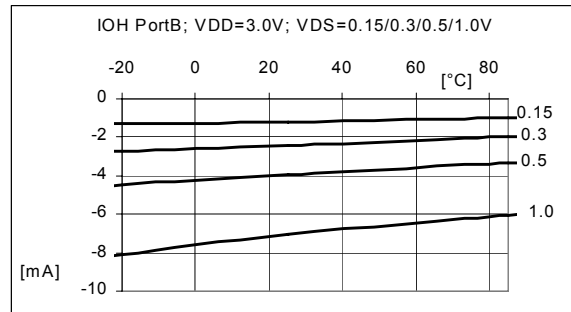
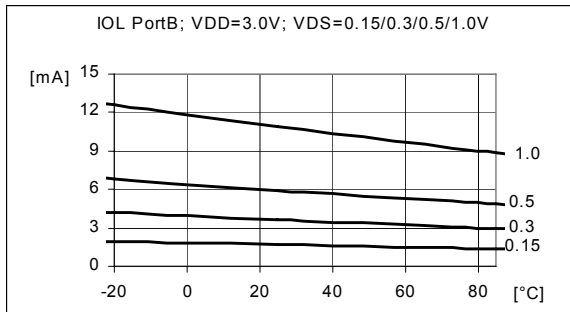
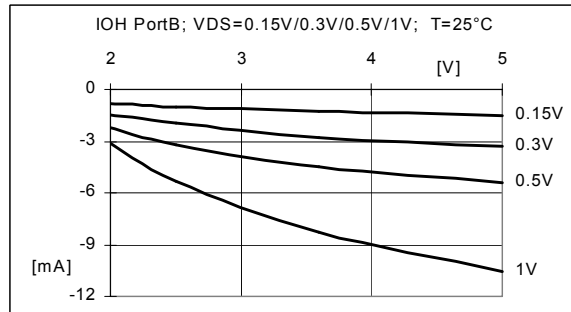
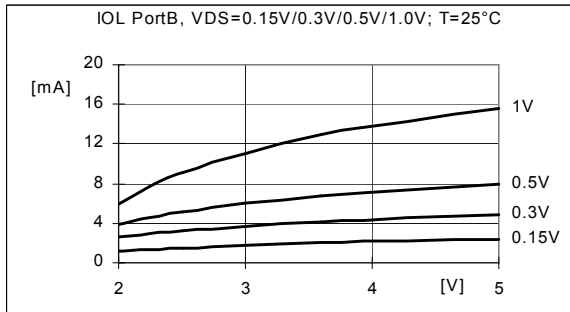

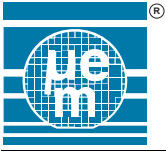

20 EM6521 Electrical Specification

20.1 Absolute Maximum Ratings

	Min.	Max.	Units
Power supply $V_{DD} - V_{SS}$	- 0.2	+ 6.0	V
Input voltage	$V_{SS} - 0,2$	$V_{DD} + 0,2$	V
Storage temperature	- 40	+ 125	°C
Electrostatic discharge to Mil-Std-883C method 3015.7 with ref. to V_{SS}	-2000	+2000	V
Maximum soldering conditions		10s x 250°C	

Stresses above these listed maximum ratings may cause permanent damage to the device. Exposure beyond specified electrical characteristics may affect device reliability or cause malfunction.

20.2 Handling Procedures

This device has built-in protection against high static voltages or electric fields; however, anti-static precautions should be taken as for any other CMOS component. Unless otherwise specified, proper operation can only occur when all terminal voltages are kept within the supply voltage range.

20.3 Standard Operating Conditions

Parameter	MIN	TYP	MAX	Unit	Description
Temperature	0	25	60	°C	
V_{DD} Range	2	3.0	5.5	V	with internal voltage regulator
V_{SS}		0		V	Reference terminal
CVDDCA (note 1)	100			nF	regulated voltage capacitor
f _q		32768		Hz	nominal frequency
R _{qs}		35		kOhm	typical quartz serial resistance
CL		8.2		pF	typical quartz load capacitance
df/f		+/- 30		ppm	quartz frequency tolerance

Note 1: This capacitor filters switching noise from V_{DD} to keep it away from the internal logic cells. In noisy systems the capacitor should be chosen bigger than minimum value.

20.4 DC Characteristics - Power Supply

Conditions: $V_{DD} = 3.0V$, $T = 25^{\circ}C$, unless otherwise specified

Parameter	Conditions	Symb.	Min.	Typ.	Max.	Unit
ACTIVE Supply Current (in active mode with LCD on)	(note2,3)	I_{VDDa}		11	15	μA
	0 ... 60°C (note2,3)	I_{VDDa}			16	μA
STANDBY Supply Current (in Halt mode, LCDOff)		I_{VDDh}		1.8	3	μA
	0 ... 60°C	I_{VDDh}			3.5	μA
SLEEP Supply Current		I_{VDDs}		0.1	0.3	μA
	0 ... 60°C	I_{VDDs}			0.5	μA
POR static level	0 ... 60°C, No Load on V_{reg}	V_{POR}		1.6	2.0	V
RAM data retention	0 ... 60°C	V_{rd}	1.6			V
Regulated voltage	Halt Mode, No Load	V_{reg}		2	2.3	V

Note 2: LCD Display NOT connected.

Note 3: For test reasons, the user has to provide a test loop with successive writing and reading of two different addresses (5 instructions should be reserved for this measurement).



20.5 Supply Voltage Level Detector

Parameter	Conditions	Symbol	Min.	Typ.	Max.	Unit
SVLD voltage Level1	0 ... 60°C	VSVLD1	3.65	4.01	4.35	V
SVLD voltage Level2	0 ... 60°C	VSVLD2	2.70	2.99	3.27	V
SVLD voltage Level3	0 ... 60°C	VSVLD3	2.20	2.42	2.65	V
SVLD voltage Level4	Note 4	VSVLD4	1.82	2.01	2.20	V
SVLD voltage Level5	Note 5	VSVLD5	1.62	1.77	1.93	V
SVLD voltage Level6	Note 5	VSVLD6	1.39	1.54	1.68	V
SVLD voltage Level7	Note 5	VSVLD7	1.25	1.37	1.49	V
SVLD voltage Level8	Note 5	VSVLD8	1.11	1.22	1.34	V
Temperature coefficient				+/- 0.2		mV/°C

Note 4 : Level which may not be reached anymore because it can be lower than V_{DD} min.

Note 5 : This levels can not be reached with the EM6521, (software compatibility EM6621)

20.6 Oscillator

Conditions: T=25°C (unless otherwise specified)

Parameter	Conditions	Symb.	Min.	Typ.	Max.	Unit
Temperature stability	+15 ... +35 °C	df/f x dT			0,3	ppm /°C
Input capacitor	Ref V_{SS}	Cin	5,6	7	8,4	pF
Output capacitor	Ref V_{SS}	Cout	12,1	14	15,9	pF
Transconductance	50mVpp, V_{DD} min	Gm	2.5		15.0	μA/V
Oscillator start voltage	Tstart < 10 s	Ustart	V_{DD} min			V
Oscillator start time	$V_{DD} > V_{DD}$ Min	tdosc		0.5	3	s
System start time (oscillator + cold start + reset)		tdsys		1.5	4	s
Oscillation detector frequency	$V_{DD} > V_{DD}$ min	tDetFreq			12	kHz



EM6521

20.7 DC characteristics - I/O Pins

Conditions: T= 0 ... 60°C (unless otherwise specified)

Parameter	Conditions	Symb	Min.	Typ.	Max.	Unit
Input Low voltage						
Ports A,B,SP,Test,Reset		V _{IL}	V _{SS}		0.3 V _{DD}	V
QIN		V _{IL}	V _{SS}		0.1 V _{reg}	V
QOUT (note 7)						
Input High voltage						
Ports A,B,SP,Test,Reset		V _{IH}	0.7 V _{DD}		V _{DD}	V
QIN		V _{IH}	0.9 V _{reg}		V _{reg}	V
QOUT (note 7)						
Output Low Current						
Port B,SP, Strobe, Buzzer	V _{DD} =3.0V , V _{OL} =0.15V	I _{OL}		1.8		mA
	V _{DD} =3.0V , V _{OL} =0.30V	I _{OL}		3.6		mA
	V _{DD} =3.0V , V _{OL} =0.50V	I _{OL}		5.8		mA
	V _{DD} =3.0V , V _{OL} =1.00V	I _{OL}	7	11.0		mA
Output High Current						
Port B,SP, Strobe, Buzzer	V _{DD} =3.0V , V _{OH} = V _{DD} -0.15V	I _{OH}		-1.2		mA
	V _{DD} =3.0V , V _{OH} = V _{DD} -0.30V	I _{OH}		-2.4		mA
	V _{DD} =3.0V , V _{OH} = V _{DD} -0.50V	I _{OH}		-3.9		mA
	V _{DD} =3.0V , V _{OH} = V _{DD} -1.00V	I _{OH}		-7.0	-4.5	mA
Input Pull-down Test, Reset	V _{DD} =3.0V, Pin at 3.0V, 25°C	RPD		15k		Ohm
Input Pull-down Port A,B,SP	V _{DD} =3.0V, Pin at 3.0V, 25°C	RPD	70k	100k	130k	Ohm
Input Pull-up Port A,B,SP	V _{DD} =3.0V, Pin at 0.0V, 25°C	RPU	72k	103k	134k	Ohm

Note 7 ; QOUT (OSC2) is used only with Quartz.

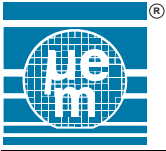

20.8 LCD SEG[20:1] Outputs

Conditions: T=25°C (unless otherwise specified)

Parameter	Conditions	Symb.	Min.	Typ.	Max.	Unit
Driver Impedance Level 0	I _{out} = ±5μA, Ext. Supply	RSEGVL0			20	KOhm
Driver Impedance Level 1	I _{out} = ±5μA, Ext Supply	RSEGVL1			20	KOhm
Driver Impedance Level 2	I _{out} = ±5μA, Ext Supply	RSEGVL2			20	KOhm
Driver Impedance Level 3	I _{out} = ±5μA, Ext Supply	RSEGVL3			20	KOhm

20.9 LCD Com[4:1] Outputs

Conditions: T=25°C (unless otherwise specified)

Parameter	Conditions	Symb.	Min.	Typ.	Max.	Unit
Driver Impedance Level 0	I _{out} = ±5μA, Ext. Supply	RcomVL0			10	KOhm
Driver Impedance Level 1	I _{out} = ±5μA, Ext. Supply	RcomVL1			10	KOhm
Driver Impedance Level 2	I _{out} = ±5μA, Ext Supply	RcomVL2			10	KOhm
Driver Impedance Level 3	I _{out} = ±5μA, Ext Supply	RcomVL3			10	KOhm

20.10 DC Output Component

Conditions: T=25°C (unless otherwise specified)

Parameter	Conditions	Symb.	Min.	Typ.	Max.	Unit
DC Output component	No Load	±VDC _{com}			20	mV

20.11 LCD Voltage Multiplier

Conditions: T=25°C, All Multiplier Capacitors 100nF, freq=512Hz. (unless otherwise specified)

Parameter	Conditions	Symb.	Min.	Typ.	Max.	Unit
Voltage Bias Level 1	1μA load	VVL1	0.95	1.05	1.17	V
Voltage Bias Level 2	1μA load	VVL2		2.10		V
Voltage Bias Level 3	1μA load	VVL3		3.15		V
Temp dependency VVL1	1μA load, 0 ... 60°C	dVVL1/dT		-4.9		mV/°C



EM6521

21 Pad Location Diagram

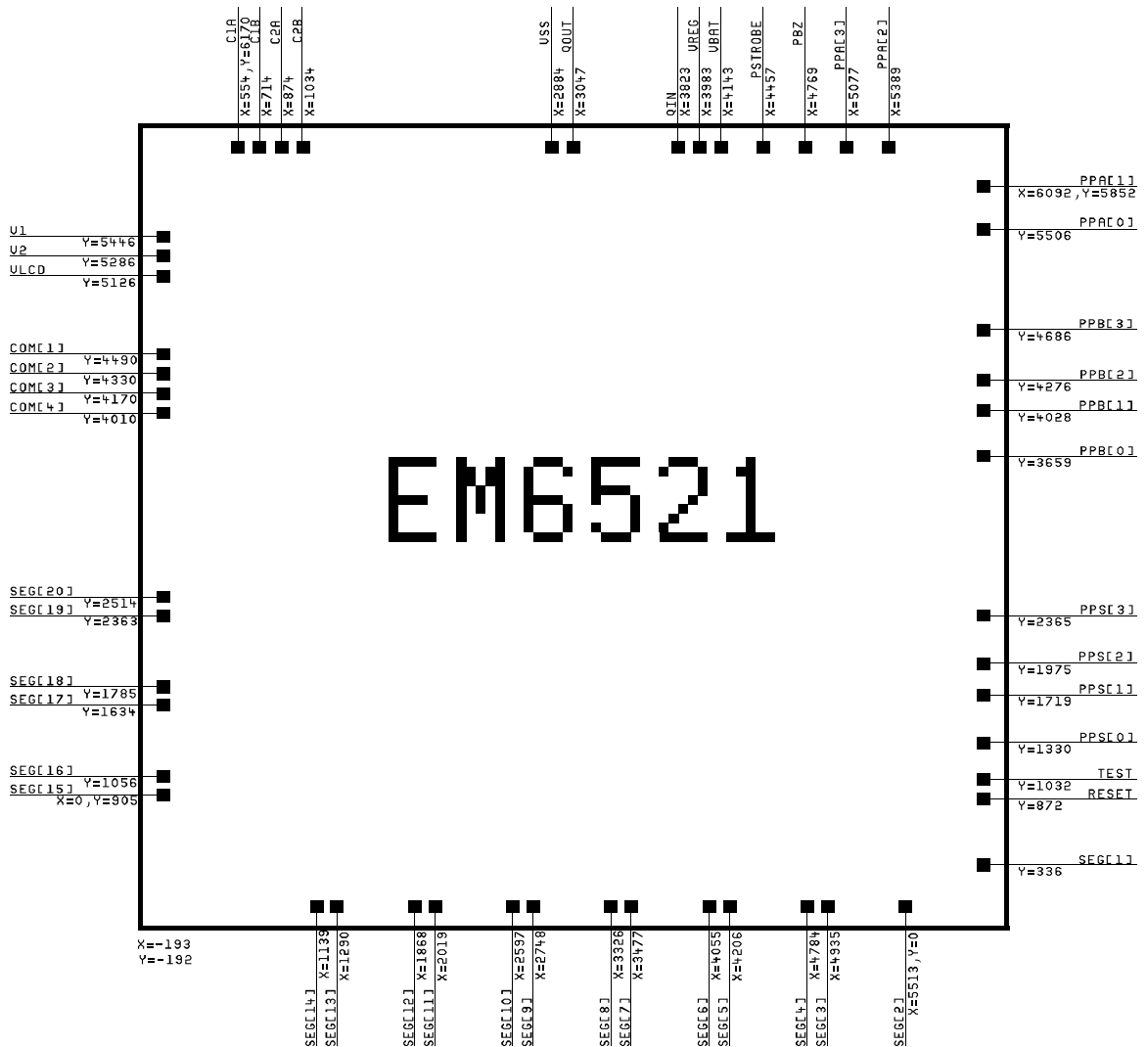

CHIP SIZE is X = 6477 by Y = 6553 Microns or X = 255 by Y = 258 Mils

NOTE : THE ORIGIN (0,0) IS THE LOWER LEFT COORDINATE OF CENTER PADS
THE LOWER LEFT CORNER OF THE CHIP SHOWS DISTANCES TO ORIGIN

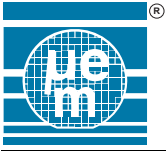

EM6521

22 Package & Ordering information

The default package for the EM6521 microcontroller is the TQFP52 10x10x1 mm.

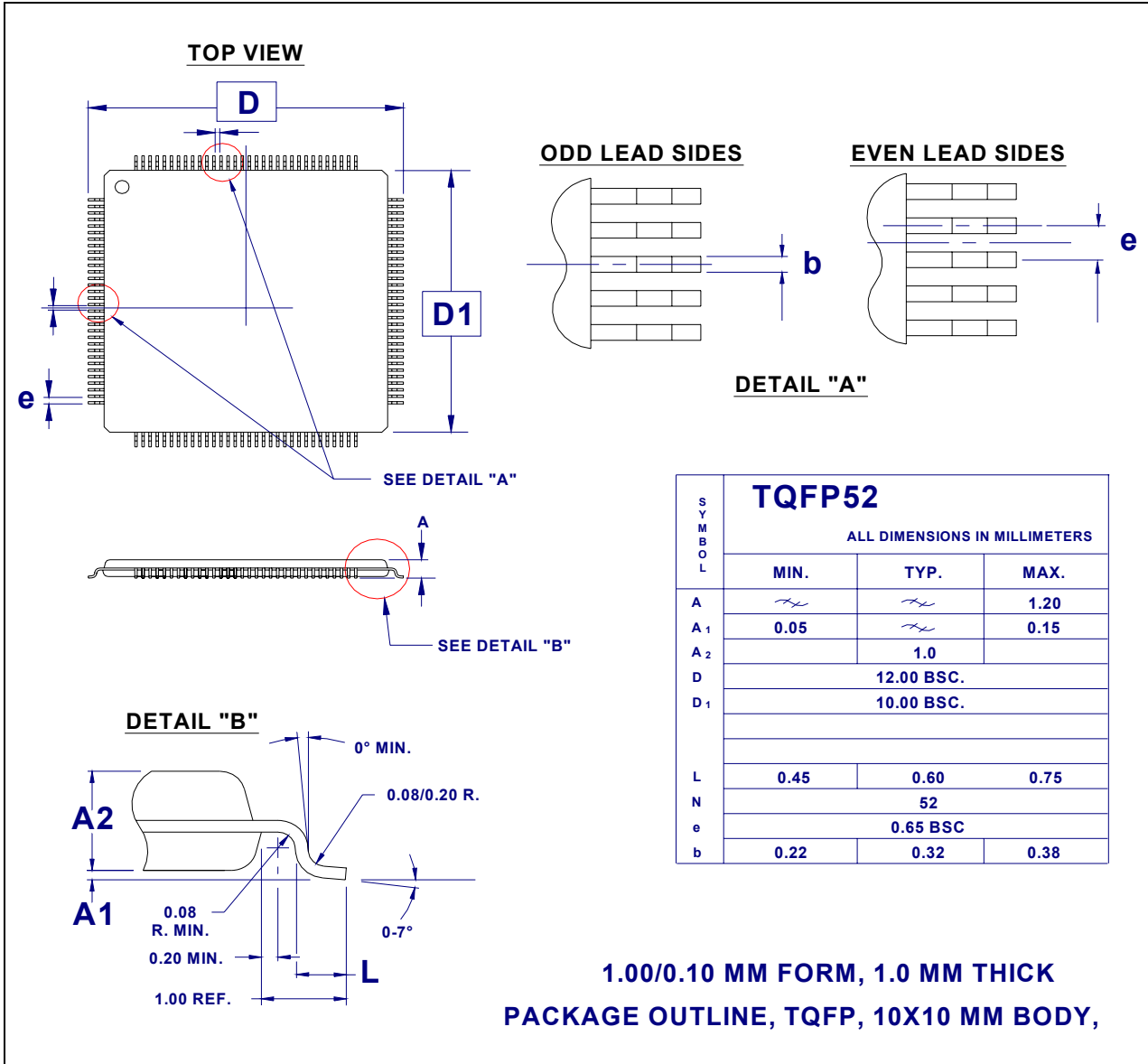

22.1 Ordering Information

Ordering Part Number

Part Number	Package/Die Form	Delivery Form/ Thickness
EM6521%%TQ52D	TQFP 52 pin	Trays (Plate)
EM6521%%WP11	Die in waffle pack	11 mils

Please make sure to give the complete Part Number when ordering, including the 3-digit version. The version is made of 3 digits %%%: the first one is a letter and the last two are numbers, e.g. P04 , P07, P12, etc.
 For other delivery forms, please contact EM Microelectronic-Marín S.A.

Please contact EM headquarters or your local EM office for any other detail. Also refer to page 60 for additional ordering information.

EM Microelectronic-Marín SA (EM) makes no warranty for the use of its products, other than those expressly contained in the Company's standard warranty which is detailed in EM's General Terms of Sale located on the Company's web site. EM assumes no responsibility for any errors which may appear in this document, reserves the right to change devices or specifications detailed herein at any time without notice, and does not make any commitment to update the information contained herein. No licenses to patents or other intellectual property of EM are granted in connection with the sale of EM products, expressly or by implications. EM's products are not authorized for use as components in life support devices or systems.