

Ordering number : ENA1021



SANYO Semiconductors

DATA SHEET

CMOS IC
LC75100M — Digital Echo IC with Microphone Amplifier Circuit

Overview

The LC75100M is a digital echo IC that incorporates a microphone amplifier and is ideal for use in minicompo and other audio systems.

Functions

- Digital echo IC incorporating a microphone amplifier.

Specitications

Absolute Maximum Rating at Ta = 25°C, VSS = 0V

Parameter	Symbol	Pin Name	Conditions	Ratings	Unit
Maximum supply voltage	VDD max	VDD		10.5	V
Allowable power dissipation	Pd max		Ta≤70°C	350	mW
Operating ambient temperature	Topr			-20 to +70	°C
Storage ambient temperature	Tstg			-40 to +125	°C

Allowable Operating Ranges (Operating Conditions) at Ta = 25°C

Parameter	Symbol	Pin Name	min	typ	max	unit
Recommended supply voltage	VDD	VDD		9.0		V
Operating supply voltage range	VDDopg	VDD	8.0		10.0	
Input high-level voltage	VIH		2.0		3.5	V
Input low-level voltage	VIL		0		0.5	V
Input pulse width	tφW		1.0			μs
Hold time	thold		1.0			μs
Operating frequency	fopg				500	kHz

■ Any and all SANYO Semiconductor Co.,Ltd. products described or contained herein are, with regard to "standard application", intended for the use as general electronics equipment (home appliances, AV equipment, communication device, office equipment, industrial equipment etc.). The products mentioned herein shall not be intended for use for any "special application" (medical equipment whose purpose is to sustain life, aerospace instrument, nuclear control device, burning appliances, transportation machine, traffic signal system, safety equipment etc.) that shall require extremely high level of reliability and can directly threaten human lives in case of failure or malfunction of the product or may cause harm to human bodies, nor shall they grant any guarantee thereof. If you should intend to use our products for applications outside the standard applications of our customer who is considering such use and/or outside the scope of our intended standard applications, please consult with us prior to the intended use. If there is no consultation or inquiry before the intended use, our customer shall be solely responsible for the use.

■ Specifications of any and all SANYO Semiconductor Co.,Ltd. products described or contained herein stipulate the performance, characteristics, and functions of the described products in the independent state, and are not guarantees of the performance, characteristics, and functions of the described products as mounted in the customer's products or equipment. To verify symptoms and states that cannot be evaluated in an independent device, the customer should always evaluate and test devices mounted in the customer's products or equipment.



LC75100M

Electrical Characteristics at Ta=25°C, V_{DD}=9.0V, f_{in}=1kHz, R_L=10kΩ

Parameter	Symbol	Pin	Conditions	min	typ	max	unit
Quiescent current	I _{DDO}	V _{DD}			13	60	mA
Clock frequency	FCLK	OSC	OSC Ex.R=22kΩ	1.82	2.6	3.38	MHz
Mic-AMP (Input=MICIN1/MICIN2, Output=MICOUT1/MICOUT2, V _{IN} =-46dBV, VALC=VREF-1.414V, Mic-AMP NF Ex.R=6.2kΩ)							
Mic gain 1	VGM1		Mic-AMP NF Ex.R=0Ω	+50	+53	+56	dB
Mic gain 2	VGM2		Mic-AMP NF Ex.R=6.2kΩ	+33	+36	+39	dB
Maximum output voltage	VoTM		Mic Gain=+36dB, THD=1%, ALC=OFF	1.75			V _{rms}
Total harmonic distortion 1	THDM1		Mic Gain=+36dB, ALC=OFF, V _O =-10dBV		0.3	1.0	%
Total harmonic distortion 2	THDM2		Mic Gain=+36dB, ALC=ON, V _O =-10dBV, V _{IN} =0dBV		1.5	2.0	%
Output noise voltage	VNOM		Mic Gain=+36dB, JIS-A		-60	-55	dBV
Input impedance	ZiM			37	50	62	kΩ
ALC attack time	TaA				30		ms
ALC release time	TaR				1.0		s
Digital Echo (Input=IN1/IN2, Output=ECHOOOUT, V _{IN} =-10dBV, Delay Time=100ms, Mic volume 1/2=0dB, feedback volume=-∞)							
Delay time	DT	ECHOOOUT	FCLK=2.6MHz		100		ms
Output level deviation	VGE	ECHOOOUT		+2.5	+5.5	+8.5	dB
Maximum output voltage	VoE	ECHOOOUT	THD=10%	1.5			V _{rms}
Total harmonic distortion	THDE	ECHOOOUT	Filter=A Filter		0.5	2.0	%
Output noise voltage	VNOE	ECHOOOUT	Filter=A Filter		-65	-55	dBV
Stereo Line (Input=LCHIN/RCHIN, Output=LCHOUT/RCHOUT, V _{IN} =-10dBV, Line select=STEREO, Mic volume 1/2=ECHO volume=-∞)							
Output level deviation	VGS	LCHOUT/RCHOUT	V _{IN} =-10dBV	-2.5	-0.5	+1.5	dB
Maximum output voltage	VoS	LCHOUT/RCHOUT	THD=1%	1.5			V _{rms}
Total harmonic distortion	THDS	LCHOUT/RCHOUT	JIS-A, Stereo out		0.03	0.1	%
Output noise voltage	VNOS	LCHOUT/RCHOUT	JIS-A, ECHO OFF		-85	-75	dBV
Vocal removal rate	VC	LCHOUT/RCHOUT	JIS-A, V _{IN} =-10dBV	-20	-18	-16	dB

Package Dimensions

unit : mm (typ)

3263

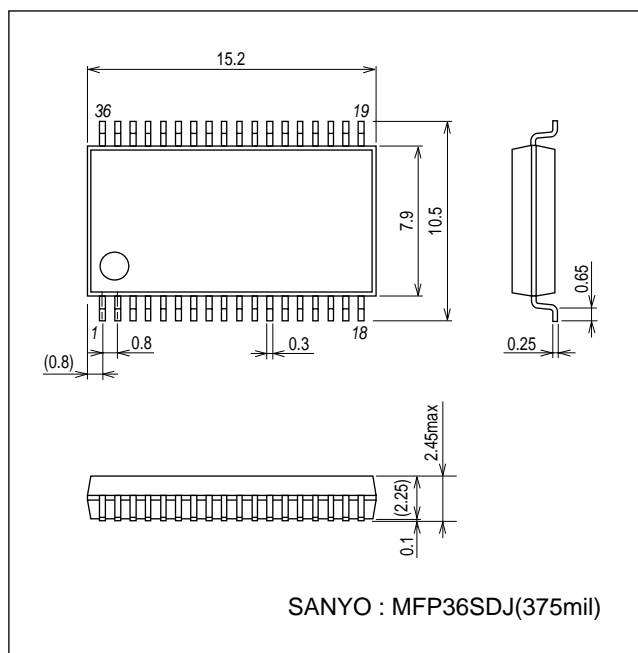

LC75100M

Pin Assignment

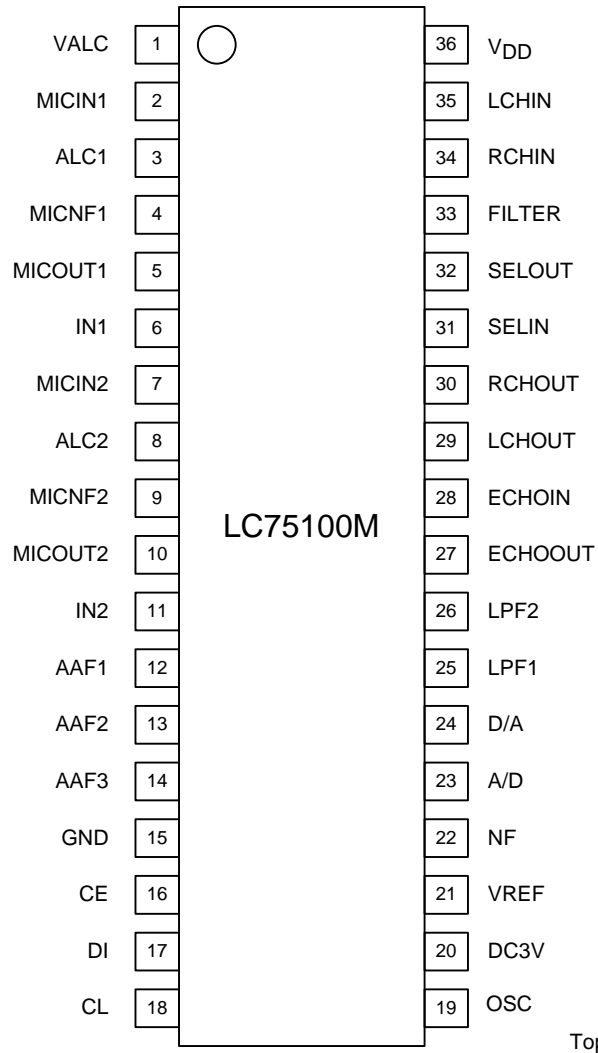

Top view

LC75100M

System Configuration Diagram

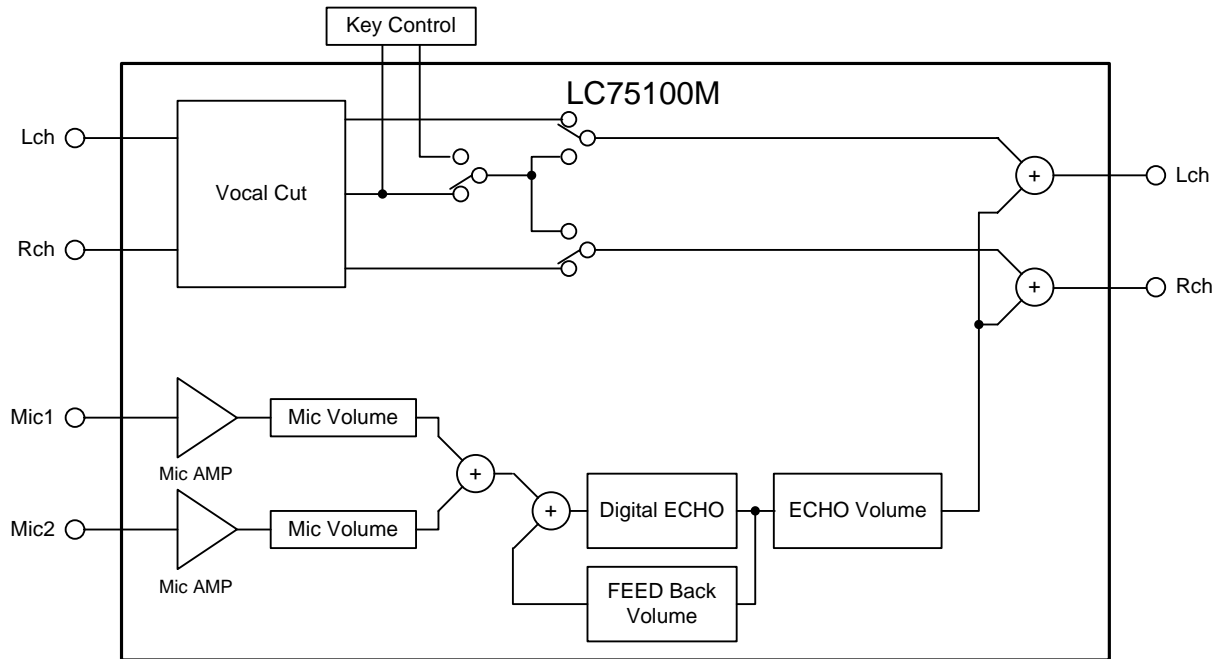

Block Diagram

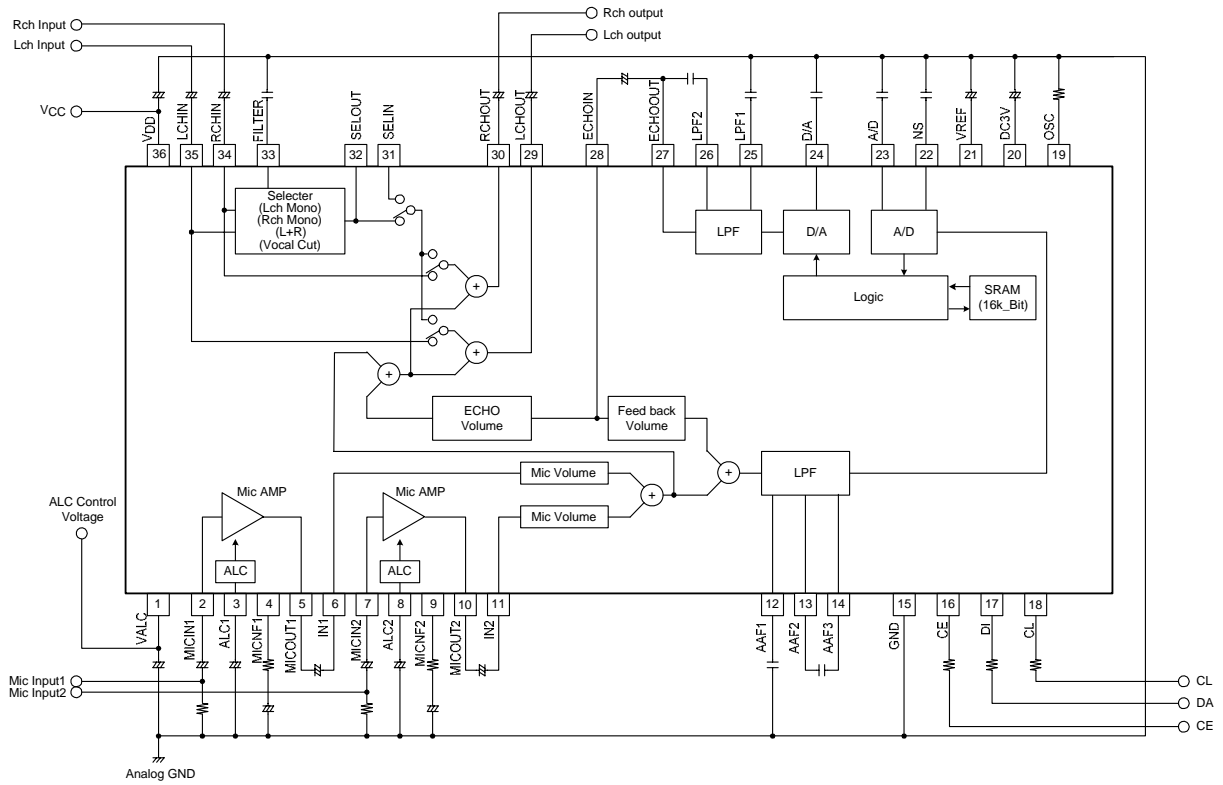

LC75100M

Pin Description

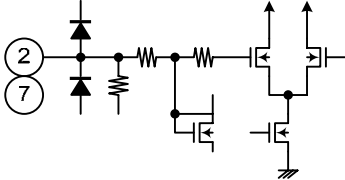
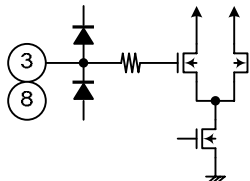
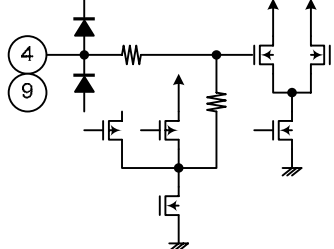
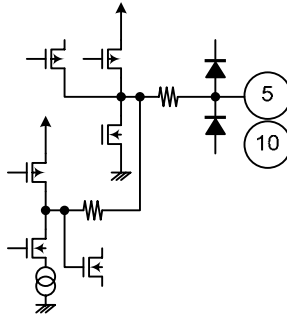
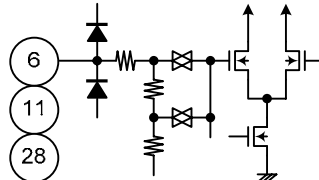
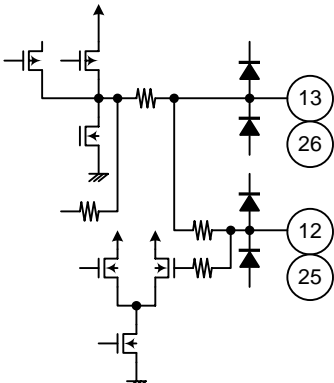
Pin No.	Pin Name	Voltage	Internal Equivalent Circuit	Description
1	VALC			ALC detection voltage setting pin
2 7	MICIN1 MICIN2	$1/2 V_{DD}$		Mic signal input 1 Mic signal input 2
3 8	ALC1 ALC2			Auto level control pin 1 Auto level control pin 2
4 9	MICNF1 MICNF2	$1/2 V_{DD}$		Mic feedback signal input pin 1 Mic feedback signal input pin 2
5 10	MICOUT1 MICOUT2	$1/2 V_{DD}$		Mic signal output pin 1 Mic signal output pin 2
6 11 28	IN1 IN2 ECHOIN	$1/2 V_{DD}$		ECHO circuit signal input pin 1 ECHO circuit signal input pin 2 ECHO signal input pin
12 13 25 26	AAF1 AAF2 LPF1 LPF2	$1/2 V_{DD}$		AAF input pin 1 AAF input pin 2 LPF input pin 1 LPF input pin 2

Continued on next page.

LC75100M

Continued from preceding page.

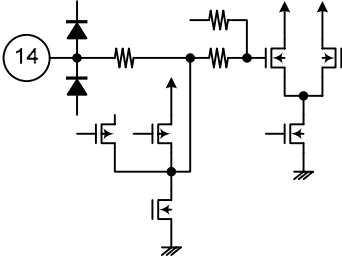
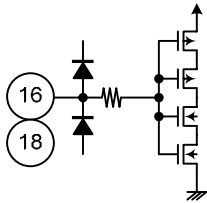
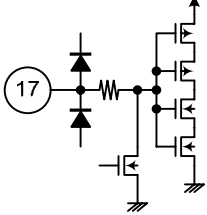
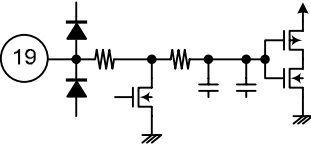
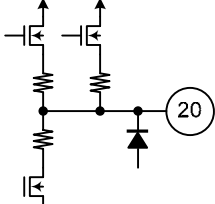
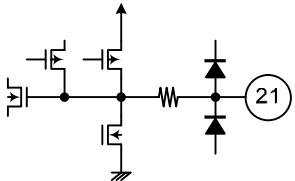
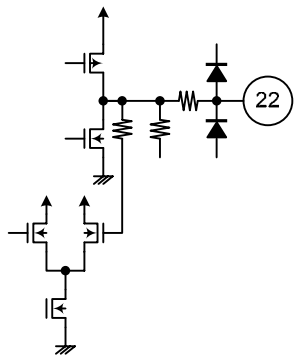
Pin No.	Pin Name	Voltage	Internal Equivalent Circuit	Description
14	AAF3	$1/2 V_{DD}$		AAF input pin 3
15	GND	0V		Analog GND
16 18	CE CL(SCL)	0V/3.3V		CCB CE pin CCB CL pin/I ² C bus SCL pin
17	DI(SDA)	0V/3.3V		CCB DI pin/I ² C bus SDA pin
19	OSC	0V/3.3V		Oscillator circuit adjustment pin
20	DC3V	3.3V		Power supply for logic block
21	VREF	$1/2 V_{DD}$		Internal reference voltage
22	NF	$1/2 V_{DD}$		A/D pin

Continued on next page.

LC75100M

Continued from preceding page.

Pin No.	Pin Name	Voltage	Internal Equivalent Circuit	Description
23 24	A/D D/A	$1/2 V_{DD}$		A/D pin D/A pin
27 29 30	ECHOOUT LCHOUT RCHOUT	$1/2 V_{DD}$		ECHO signal output pin Lch output Rch output
31	SELIN	$1/2 V_{DD}$		Selector input pin
32	SELOUT	$1/2 V_{DD}$		Selector output pin
33	FILTER	$1/2 V_{DD}$		Filter input pin 1
34 35	RCHIN LCHIN	$1/2 V_{DD}$		Rch input pin Lch input pin
36	V_{DD}			Supply voltage

LC75100M

Control Data (Serial Data Input) Format

Various settings of the LC75100M can be configured with a CCB or I²C bus. When controlling the LC75100M via an I²C bus, set and hold the CE pin at low level.

(1) CCB control

① Control register

• IN1 mode

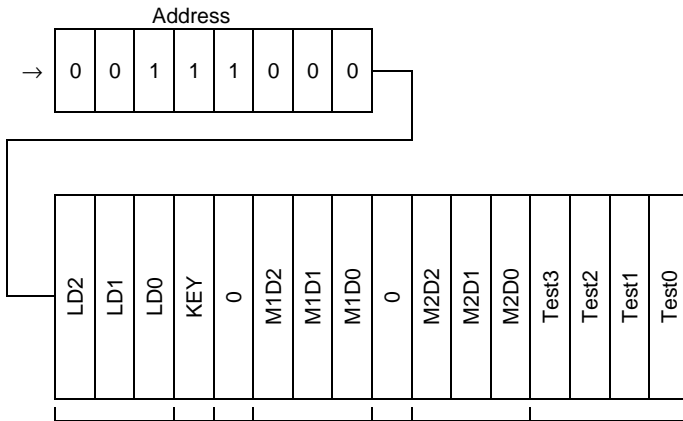

(1) Stereo Line Data

(2) Ext Key Control

(3) Mic1 Volume

(3) Mic2 Volume

(7) Test

• IN2 mode

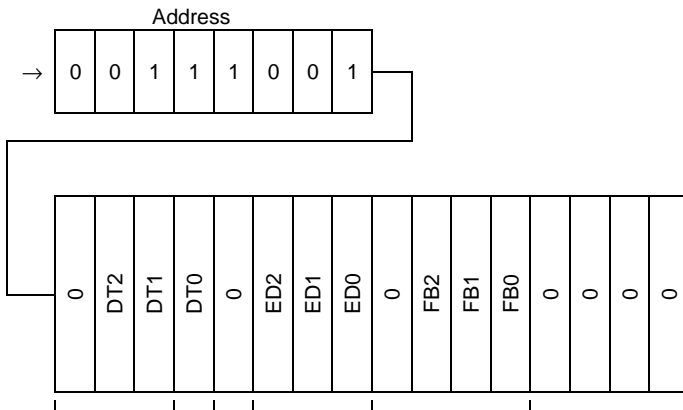

(4) Delay Time Control

(5) ECHO Volume

(6) Feedback Volume

LC75100M

② Serial data input

- CL: Normal Hi

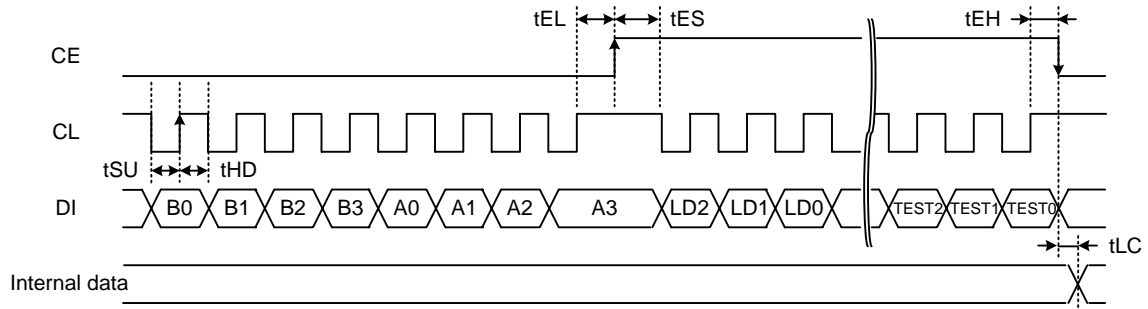

- CL: Normal Low

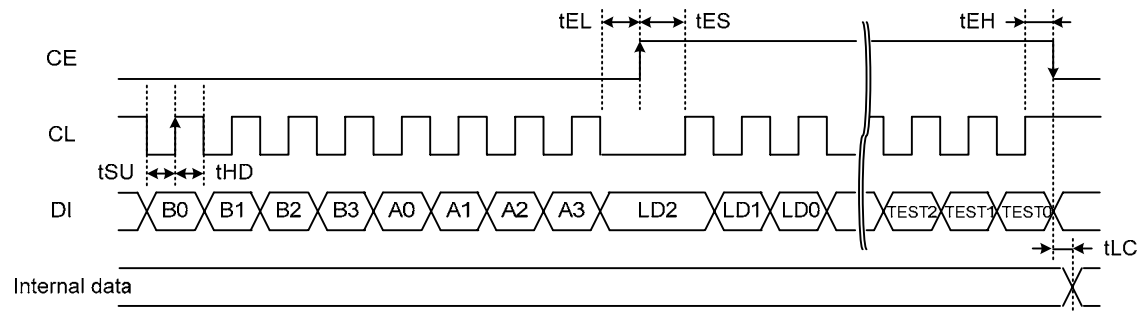

(2) I²C bus control

I²C bus register

The I²C (Inter IC) bus is a bus system developed by Philips Corporation.

It controls the start and stop condition with SDA (Serial Data) and SCL (Serial Clock). The outputs of these signals are of open drain type and wired OR.

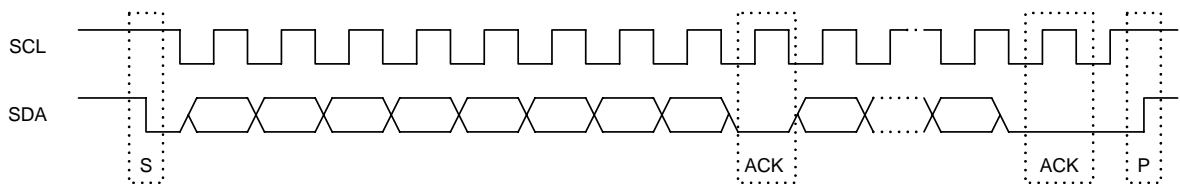

S: Start condition/P: Stop condition/ACK: Acknowledge

Data is transferred MSB first.

One unit is made up of 8 bits. ACK is returned by the slave for acknowledgement.

The slave IC reads the data on the rising edge of SCL.

The master IC changes the data on the falling edge of SCL.

① Control registers

- Slave Address

MSB				LSB			
0	0	1	1	1	0	0	0

Note: The LC75100M can be used in the receive only mode if the LSB is set to 0.

LC75100M

• I²C Data

Function	Sub Address		Data							
	BINARY	HEX	D7	D6	D5	D4	D3	D2	D1	D0
Stereo line select	0000 0001	01	LD2	LD1	LD0	KEY	0	MID2	MID1	MID0
Mic volume control	0000 0010	02	0	M2D2	M2D1	M2D0	TEST3	TEST2	TEST1	TEST0
Delay time control	0000 0011	03	0	DT2	DT1	DT0	0	ED2	ED1	ED0
ECHO/Feedback volume	0000 1000	04	0	FB2	FB1	FB0	0	0	0	0

*: All test bits must be set to 0.

Control Data Description (common to both CCB and I²C bus)

No	Control Block/Data	Description	Related Data																																								
(1)	Line Select LD2 LD1 LD0	<ul style="list-style-type: none"> Determines the line output. <table border="1" style="margin-left: 20px;"> <thead> <tr> <th>LD2</th> <th>LD1</th> <th>LD0</th> <th></th> </tr> </thead> <tbody> <tr> <td>0</td> <td>0</td> <td>0</td> <td>Stereo output</td> </tr> <tr> <td>0</td> <td>0</td> <td>1</td> <td>Lch Mono output</td> </tr> <tr> <td>0</td> <td>1</td> <td>0</td> <td>Rch Mono output</td> </tr> <tr> <td>0</td> <td>1</td> <td>1</td> <td>L+R/2 output</td> </tr> <tr> <td>1</td> <td>0</td> <td>0</td> <td>Vocal cut output</td> </tr> <tr> <td>1</td> <td>0</td> <td>1</td> <td>Reserve</td> </tr> <tr> <td>1</td> <td>1</td> <td>0</td> <td>Reserve</td> </tr> <tr> <td>1</td> <td>1</td> <td>1</td> <td>Reserve</td> </tr> </tbody> </table>	LD2	LD1	LD0		0	0	0	Stereo output	0	0	1	Lch Mono output	0	1	0	Rch Mono output	0	1	1	L+R/2 output	1	0	0	Vocal cut output	1	0	1	Reserve	1	1	0	Reserve	1	1	1	Reserve					
LD2	LD1	LD0																																									
0	0	0	Stereo output																																								
0	0	1	Lch Mono output																																								
0	1	0	Rch Mono output																																								
0	1	1	L+R/2 output																																								
1	0	0	Vocal cut output																																								
1	0	1	Reserve																																								
1	1	0	Reserve																																								
1	1	1	Reserve																																								
(2)	External key control enable/disable key	<ul style="list-style-type: none"> Determines the path that uses the external key control. <table border="1" style="margin-left: 20px;"> <thead> <tr> <th>KEY</th> <th>External Key Control</th> </tr> </thead> <tbody> <tr> <td>0</td> <td>Disabled</td> </tr> <tr> <td>1</td> <td>Enabled</td> </tr> </tbody> </table>	KEY	External Key Control	0	Disabled	1	Enabled																																			
KEY	External Key Control																																										
0	Disabled																																										
1	Enabled																																										
(3)	Mic volume gain data M1D2 M1D1 M1D0 M2D2 M2D1 M2D0	<ul style="list-style-type: none"> Determines the gain of mic inputs 1 and 2. <table border="1" style="margin-left: 20px;"> <thead> <tr> <th>M1D2</th> <th>M1D1</th> <th>M1D0</th> <th></th> </tr> <tr> <th>M2D2</th> <th>M2D1</th> <th>M2D0</th> <th></th> </tr> </thead> <tbody> <tr> <td>0</td> <td>0</td> <td>0</td> <td>0dB</td> </tr> <tr> <td>0</td> <td>0</td> <td>1</td> <td>-2dB</td> </tr> <tr> <td>0</td> <td>1</td> <td>0</td> <td>-4dB</td> </tr> <tr> <td>0</td> <td>1</td> <td>1</td> <td>-6dB</td> </tr> <tr> <td>1</td> <td>0</td> <td>0</td> <td>-9dB</td> </tr> <tr> <td>1</td> <td>0</td> <td>1</td> <td>-12dB</td> </tr> <tr> <td>1</td> <td>1</td> <td>0</td> <td>-15dB</td> </tr> <tr> <td>1</td> <td>1</td> <td>1</td> <td>-∞</td> </tr> </tbody> </table>	M1D2	M1D1	M1D0		M2D2	M2D1	M2D0		0	0	0	0dB	0	0	1	-2dB	0	1	0	-4dB	0	1	1	-6dB	1	0	0	-9dB	1	0	1	-12dB	1	1	0	-15dB	1	1	1	-∞	
M1D2	M1D1	M1D0																																									
M2D2	M2D1	M2D0																																									
0	0	0	0dB																																								
0	0	1	-2dB																																								
0	1	0	-4dB																																								
0	1	1	-6dB																																								
1	0	0	-9dB																																								
1	0	1	-12dB																																								
1	1	0	-15dB																																								
1	1	1	-∞																																								

Continued on next page.

LC75100M

Continued from preceding page.

No	Control Block/Data	Description	Related Data																																				
(4)	Delay time data DT2 DT1 DT0	<ul style="list-style-type: none"> Determines the echo delay time. <table border="1" style="margin-left: auto; margin-right: auto; border-collapse: collapse; text-align: center;"> <thead> <tr> <th>DT2</th> <th>DT1</th> <th>DT0</th> <th></th> </tr> </thead> <tbody> <tr><td>0</td><td>0</td><td>0</td><td>OFF</td></tr> <tr><td>0</td><td>0</td><td>1</td><td>75ms</td></tr> <tr><td>0</td><td>1</td><td>0</td><td>100ms</td></tr> <tr><td>0</td><td>1</td><td>1</td><td>125ms</td></tr> <tr><td>1</td><td>0</td><td>0</td><td>150ms</td></tr> <tr><td>1</td><td>0</td><td>1</td><td>175ms</td></tr> <tr><td>1</td><td>1</td><td>0</td><td>200ms</td></tr> <tr><td>1</td><td>1</td><td>1</td><td>Reserved</td></tr> </tbody> </table>	DT2	DT1	DT0		0	0	0	OFF	0	0	1	75ms	0	1	0	100ms	0	1	1	125ms	1	0	0	150ms	1	0	1	175ms	1	1	0	200ms	1	1	1	Reserved	
DT2	DT1	DT0																																					
0	0	0	OFF																																				
0	0	1	75ms																																				
0	1	0	100ms																																				
0	1	1	125ms																																				
1	0	0	150ms																																				
1	0	1	175ms																																				
1	1	0	200ms																																				
1	1	1	Reserved																																				
(5)	Echo volume gain data ED2 ED1 ED0	<ul style="list-style-type: none"> Determines the gain of the echo output. <table border="1" style="margin-left: auto; margin-right: auto; border-collapse: collapse; text-align: center;"> <thead> <tr> <th>ED2</th> <th>ED1</th> <th>ED0</th> <th></th> </tr> </thead> <tbody> <tr><td>0</td><td>0</td><td>0</td><td>0dB</td></tr> <tr><td>0</td><td>0</td><td>1</td><td>-2dB</td></tr> <tr><td>0</td><td>1</td><td>0</td><td>-4dB</td></tr> <tr><td>0</td><td>1</td><td>1</td><td>-6dB</td></tr> <tr><td>1</td><td>0</td><td>0</td><td>-9dB</td></tr> <tr><td>1</td><td>0</td><td>1</td><td>-12dB</td></tr> <tr><td>1</td><td>1</td><td>0</td><td>-15dB</td></tr> <tr><td>1</td><td>1</td><td>1</td><td>-∞</td></tr> </tbody> </table>	ED2	ED1	ED0		0	0	0	0dB	0	0	1	-2dB	0	1	0	-4dB	0	1	1	-6dB	1	0	0	-9dB	1	0	1	-12dB	1	1	0	-15dB	1	1	1	-∞	
ED2	ED1	ED0																																					
0	0	0	0dB																																				
0	0	1	-2dB																																				
0	1	0	-4dB																																				
0	1	1	-6dB																																				
1	0	0	-9dB																																				
1	0	1	-12dB																																				
1	1	0	-15dB																																				
1	1	1	-∞																																				
(6)	Feedback volume gain data FB2 FB1 FB0	<ul style="list-style-type: none"> Determines the volume of the echo feedback. <table border="1" style="margin-left: auto; margin-right: auto; border-collapse: collapse; text-align: center;"> <thead> <tr> <th>FB2</th> <th>FB1</th> <th>FB0</th> <th></th> </tr> </thead> <tbody> <tr><td>0</td><td>0</td><td>0</td><td>-2dB</td></tr> <tr><td>0</td><td>0</td><td>1</td><td>-4dB</td></tr> <tr><td>0</td><td>1</td><td>0</td><td>-6dB</td></tr> <tr><td>0</td><td>1</td><td>1</td><td>-8dB</td></tr> <tr><td>1</td><td>0</td><td>0</td><td>-∞</td></tr> <tr><td>1</td><td>0</td><td>1</td><td>Reserve</td></tr> <tr><td>1</td><td>1</td><td>0</td><td>Reserve</td></tr> <tr><td>1</td><td>1</td><td>1</td><td>Reserve</td></tr> </tbody> </table>	FB2	FB1	FB0		0	0	0	-2dB	0	0	1	-4dB	0	1	0	-6dB	0	1	1	-8dB	1	0	0	-∞	1	0	1	Reserve	1	1	0	Reserve	1	1	1	Reserve	
FB2	FB1	FB0																																					
0	0	0	-2dB																																				
0	0	1	-4dB																																				
0	1	0	-6dB																																				
0	1	1	-8dB																																				
1	0	0	-∞																																				
1	0	1	Reserve																																				
1	1	0	Reserve																																				
1	1	1	Reserve																																				
(7)	IC test data TEST3 TEST2 TEST1 TEST0	<ul style="list-style-type: none"> Used for testing the IC. <p style="text-align: center;">TEST3 to TEST0 must all be set to 0.</p>																																					

LC75100M

Recommended Circuit (Mic-Gain=-36dB)

[CCB Control]

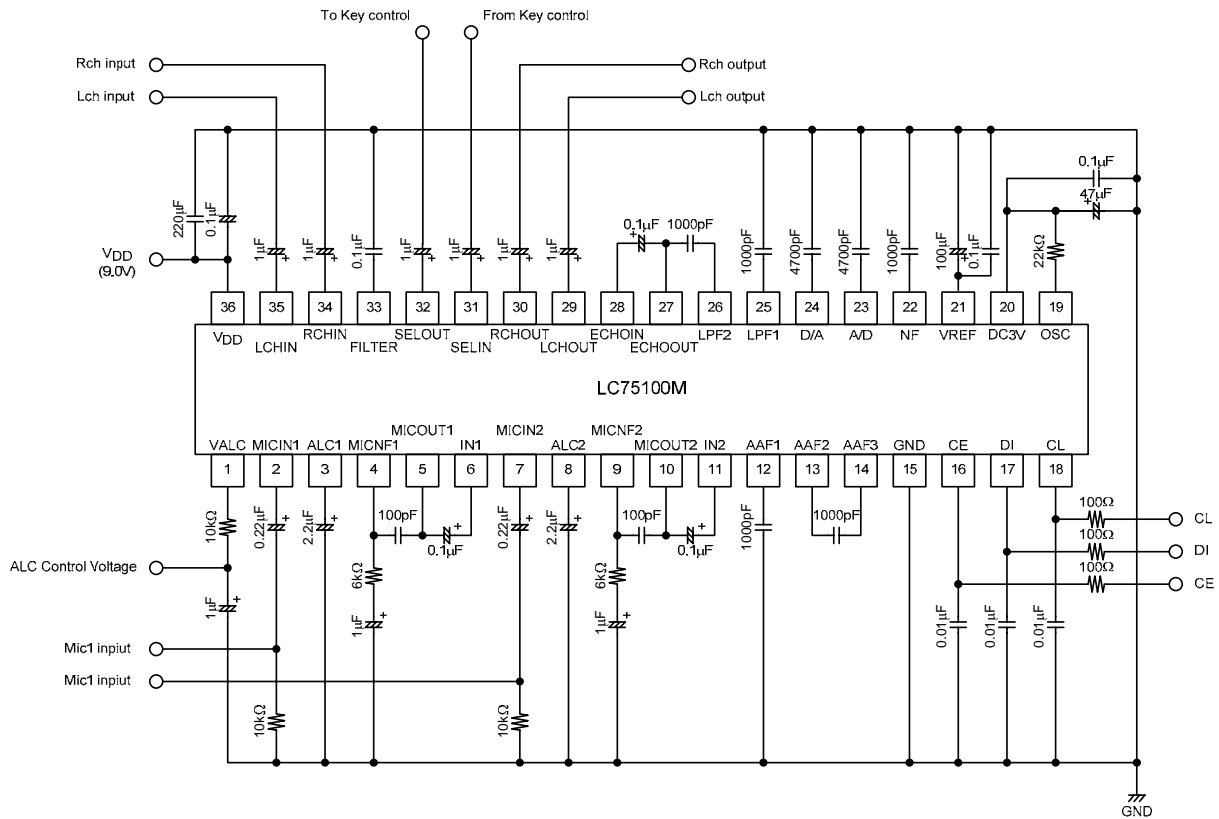

[I²C Control]

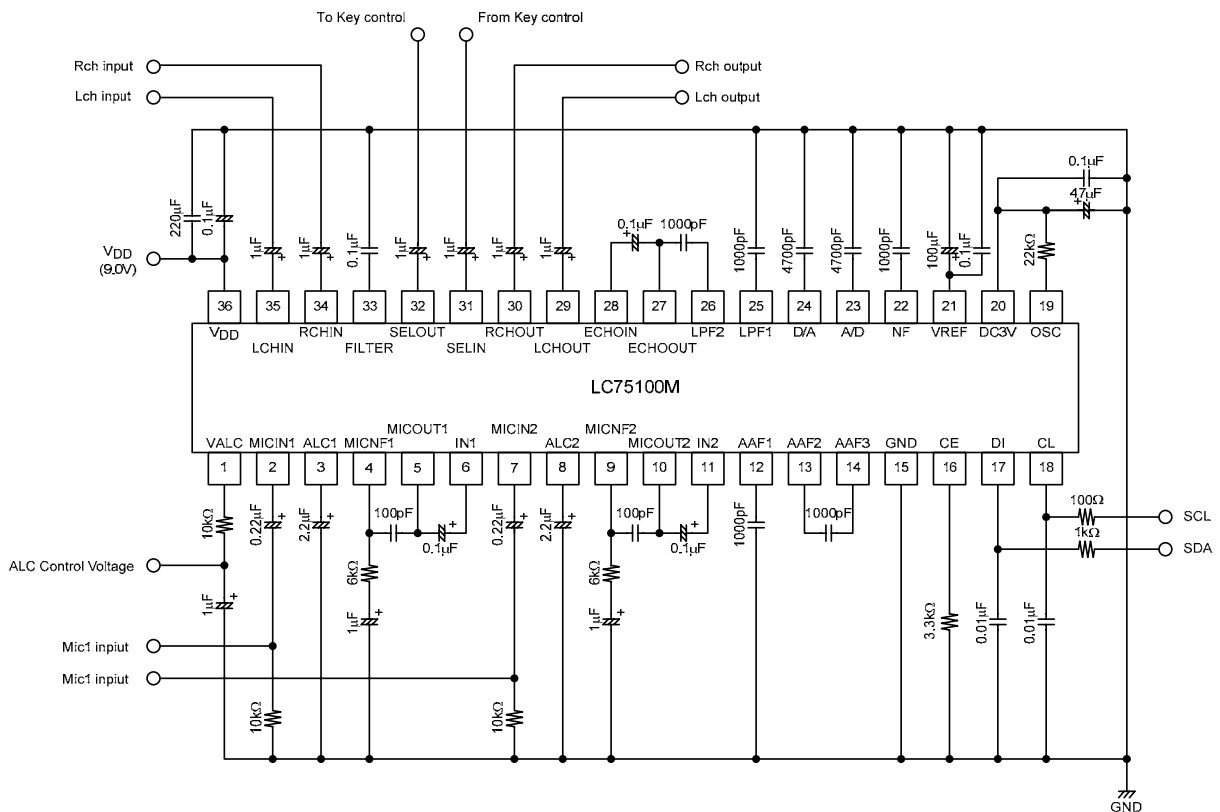

LC75100M

Setting the Mic Amplifier Gain

The mic amplifier gain can be adjusted by the resistors connected to pins 3 and 34. Moreover, the low frequency region can be cut off by connecting a capacitor. The mic amplifier has a built-in ALC (Auto Level Control) and the output level can be controlled by applying the reference voltage to pin 1.

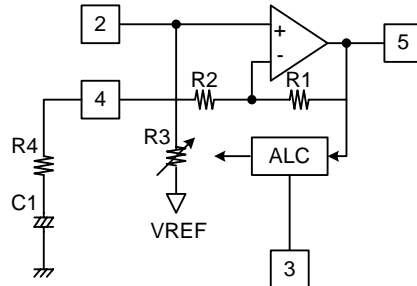

- (1) Setting the mic AMP gain
 • R1=562.3kΩ, R2=1.0kΩ

[When Mic Gain=45dB]

$$R4 = (R1 / \text{Mic Gain}) - R2$$

$$= 562.3k / 177.8 - 1k$$

$$\approx 2.2k\Omega$$

- (2) Determining the f_c

$$f_c = \frac{1}{2\pi(R1 + 1k)C1}$$

- (3) Setting the ALC operating voltage

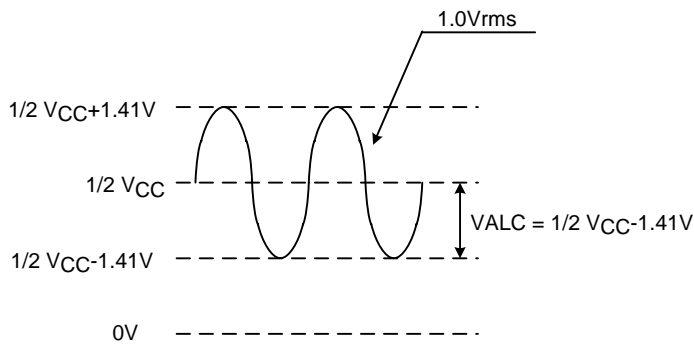

LC75100M

- SANYO Semiconductor Co.,Ltd. assumes no responsibility for equipment failures that result from using products at values that exceed, even momentarily, rated values (such as maximum ratings, operating condition ranges, or other parameters) listed in products specifications of any and all SANYO Semiconductor Co.,Ltd. products described or contained herein.
- SANYO Semiconductor Co.,Ltd. strives to supply high-quality high-reliability products, however, any and all semiconductor products fail or malfunction with some probability. It is possible that these probabilistic failures or malfunction could give rise to accidents or events that could endanger human lives, trouble that could give rise to smoke or fire, or accidents that could cause damage to other property. When designing equipment, adopt safety measures so that these kinds of accidents or events cannot occur. Such measures include but are not limited to protective circuits and error prevention circuits for safe design, redundant design, and structural design.
- In the event that any or all SANYO Semiconductor Co.,Ltd. products described or contained herein are controlled under any of applicable local export control laws and regulations, such products may require the export license from the authorities concerned in accordance with the above law.
- No part of this publication may be reproduced or transmitted in any form or by any means, electronic or mechanical, including photocopying and recording, or any information storage or retrieval system, or otherwise, without the prior written consent of SANYO Semiconductor Co.,Ltd.
- Any and all information described or contained herein are subject to change without notice due to product/technology improvement, etc. When designing equipment, refer to the "Delivery Specification" for the SANYO Semiconductor Co.,Ltd. product that you intend to use.
- Information (including circuit diagrams and circuit parameters) herein is for example only; it is not guaranteed for volume production.
- Upon using the technical information or products described herein, neither warranty nor license shall be granted with regard to intellectual property rights or any other rights of SANYO Semiconductor Co.,Ltd. or any third party. SANYO Semiconductor Co.,Ltd. shall not be liable for any claim or suits with regard to a third party's intellectual property rights which has resulted from the use of the technical information and products mentioned above.

This catalog provides information as of March, 2008. Specifications and information herein are subject to change without notice.
