

# ENERGIZER NO. EN92

**AAA**

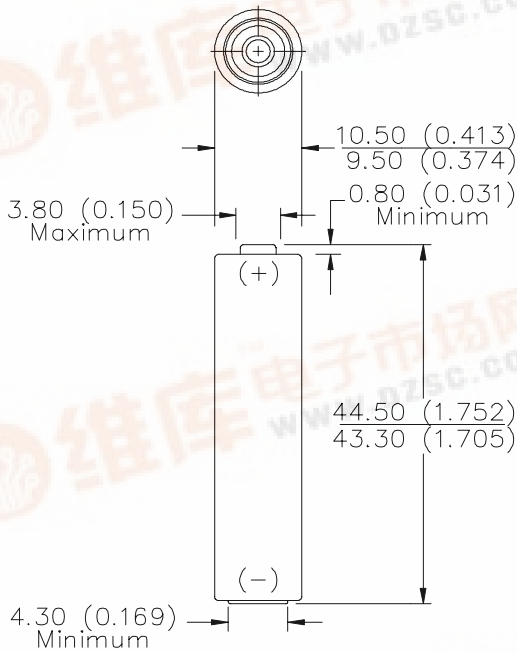

Industry Standard Dimensions in mm (inches)



**NOT INTENDED FOR RETAIL TRADE**

- Chemical System:** Alkaline  
Zinc-Manganese Dioxide (Zn/MnO<sub>2</sub>)  
(No Added Mercury or Cadmium)
- Designation:** ANSI-24A, IEC-LR03
- Battery Voltage:** 1.5 Volts
- Internal Resistance:** 205 Milliohms (Fresh)
- Operating Temp:** -18°C to 55°C (0°F to 130°F)
- Average Capacity:** 1,250 mAh (to 0.8 volts)  
(Rated capacity at 25 mA continuous drain)
- Average Weight:** 11.5 grams (0.4 oz.)
- Volume:** 3.8 cubic centimeters (0.2 cubic inch)
- Cell:** One No. 3-312 (size 'AAA')
- Jacket:** Plastic Label
- Shelf Life:** 7 years (80% of rated capacity)

**TEMPERATURE EFFECTS**  
Typical Service to 0.8 Volts

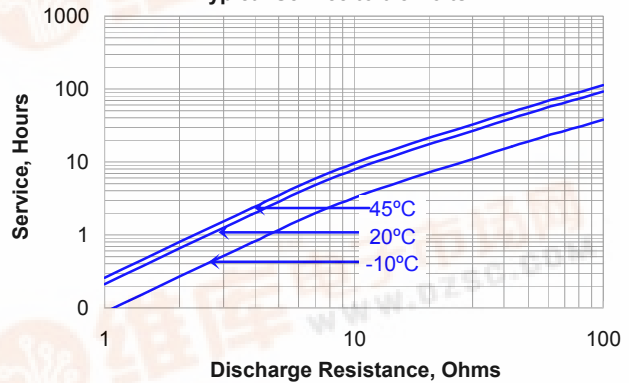

**CONSTANT RESISTANCE PERFORMANCE**  
Typical Service

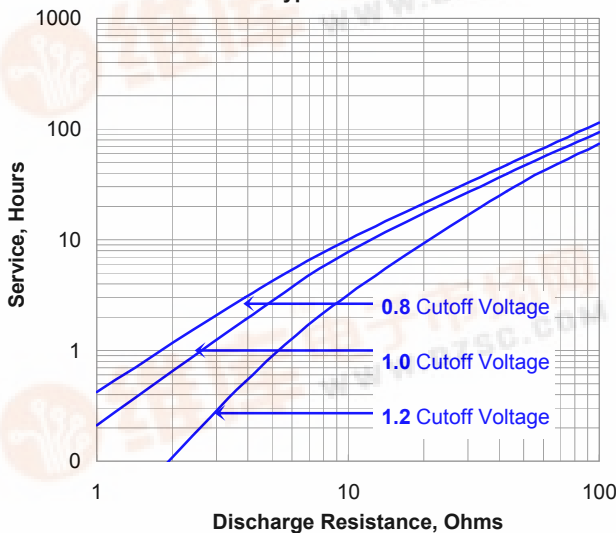

**CONSTANT CURRENT DISCHARGE**  
Typical Service

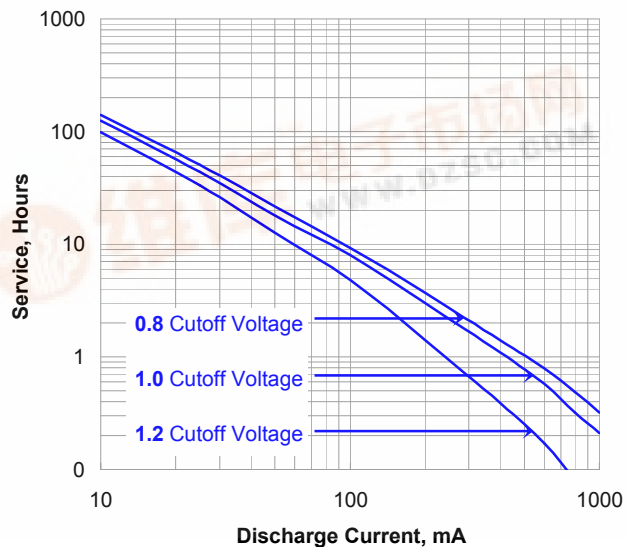

**Important Notice**

This data sheet contains information specific to batteries manufactured at the time of its publication.

**Contents herein do not constitute a warranty.**

Copyright © Eveready Battery Co. - All rights reserved



## ENERGIZER NO. EN92

**CONSTANT POWER DISCHARGE**  
Typical Service

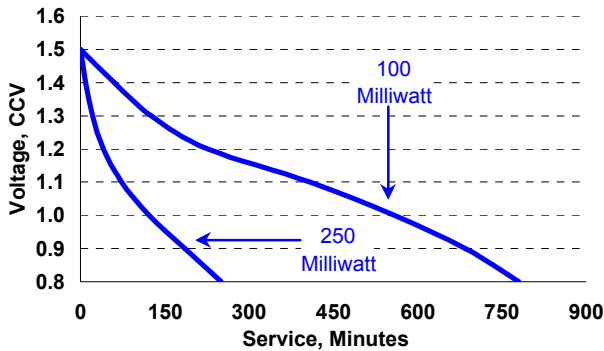

**CONSTANT POWER DISCHARGE**  
Typical Service

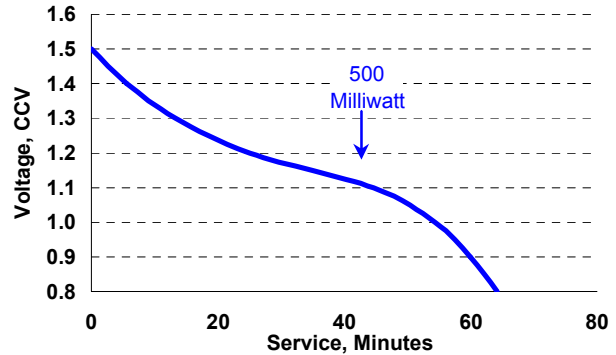

### Industry Standard Tests @ 20° C

**LIGHTING**  
5.1 ohm - 4 min/hr 8 hr/day



**PHOTOFLASH**  
600 mA - 10 sec/min 1 hr/day

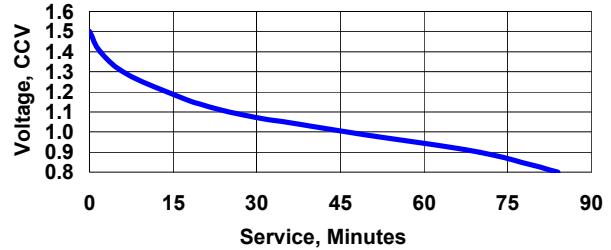

**REMOTE**  
24 ohm - 15 spm - 8 hr/day

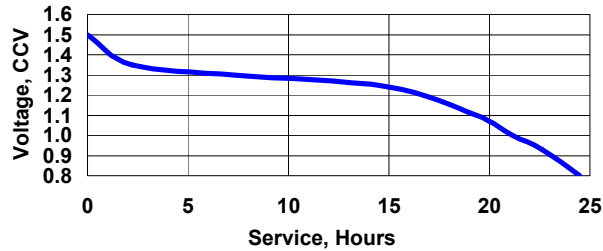

**TAPE - ELECTRONIC GAMES-DIGITAL AUDIO**  
100 mA - 1 hr/day

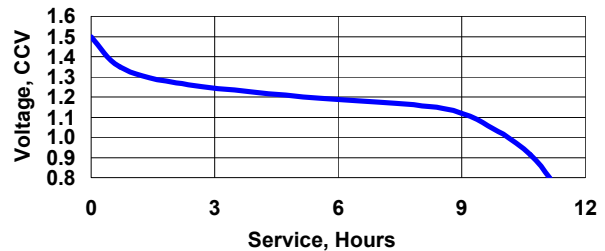

### Important Notice

This data sheet contains information specific to batteries manufactured at the time of its publication.

**Contents herein do not constitute a warranty.**

Copyright © Eveready Battery Co. - All rights reserved