

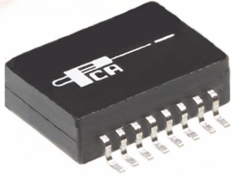

10/100Base-TX Interface PCMCIA Module EPF8181AS



- 1500 Vrms Isolation
- Robust design allows for toughest soldering processes
- Complies with or exceeds IEEE 802.3, 10/100Base-TX Standards

Electrical Parameters @ 25° C

OCL (μ H Min.)	Interwinding Capacitance (pF Max.)	Primary Leakage Inductance (μ H Max.)	Return Loss (dB Min.)			Primary DCR (Ω Max.)	
			1-30	30-60	60-80	Xmit	Rcv
100 KHz, 0.1 Vrms	@ 100 KHz, 0.1 Vrms	@ 100 KHz, 0.1 Vrms					
Xmit & Rcv		Xmit & Rcv				Xmit	Rcv
350 @ Pins 16-15 & 10-9	25	0.3	-18	-14	-10	1.5	1.0

Schematic

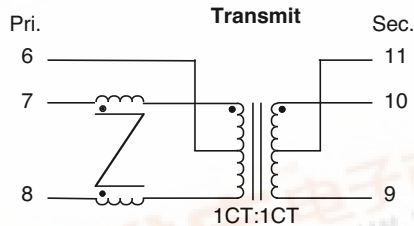
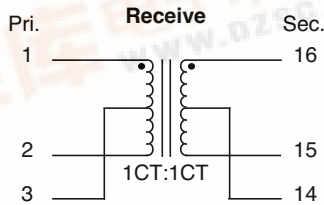

Package

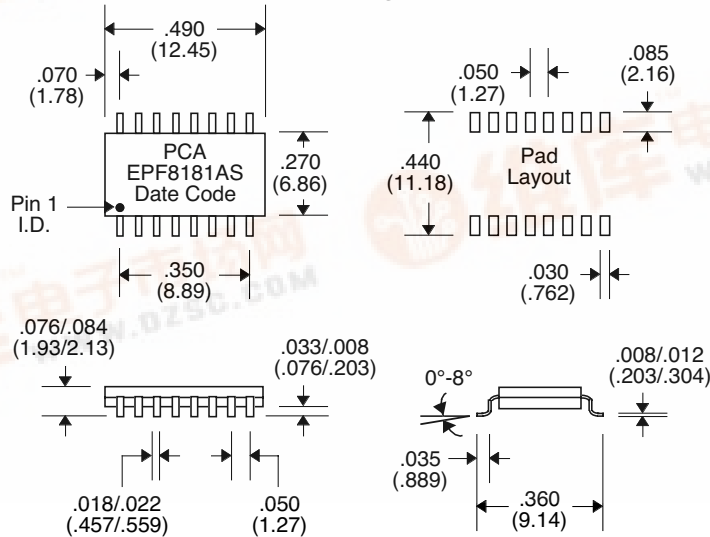

Unless Otherwise Specified Dimensions are in Inches /mm \pm .010 / .25

