



Power Choke

EPZ3035G



- Used in DC/DC Converter
- UL94V-0 Recognized Materials
- UL1446 Clas B Insulating System
- Operating Temperature : -40°C to +85°C
- Noise suppression Choke
- 1.5 A Rated Current
- 250 Vrms Isolation

Electrical Parameters @ 25° C

Inductance (mH ± 30%)	DCR (mΩ Max.)	Turns Ratio	SRF (MHz Typ.)
@10 KHz, 0.1 Vrms	Matched with ± 5%		
Pins 1-2, 3-4	Pins 1-2, 3-4	Pins 1-2 : 3-4	
1.0	60	1 : 1	2.0

Impedance Curve

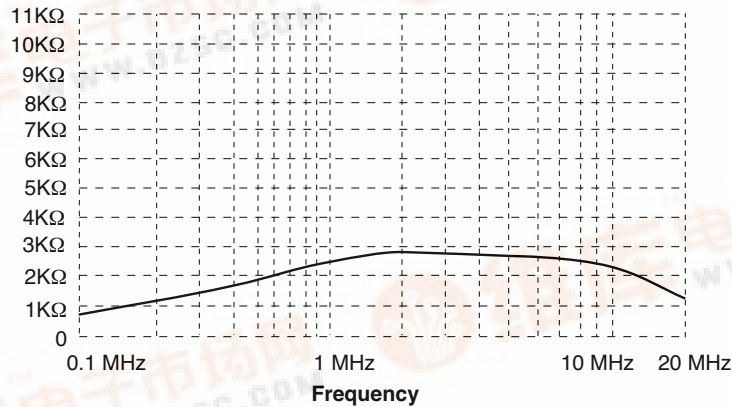

Package

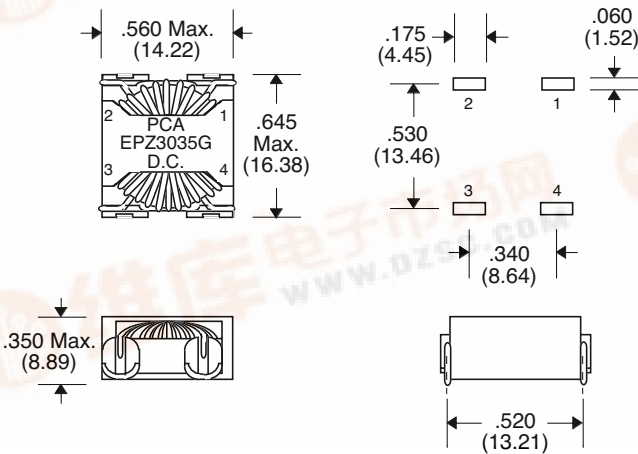

Schematic

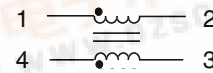

Unless Otherwise Specified Dimensions are in Inches /mm ± .010 / .25

Product performance is limited to specified parameters. Data is subject to change without prior notice.

CSZ3035G Rev. 1 10/28/03

TEL: (818) 892-0761

FAX: (818) 894-5791

http://www.pcaelectronics.com

