

BL GALAXY ELECTRICAL

ERA22-02---ERA22-10

FAST RECOVERY RECTIFIER

VOLTAGE RANGE: 200 --- 1000 V
CURRENT: 0.5 A

FEATURES

- ◇ Low cost
- ◇ Diffused junction
- ◇ Low leakage
- ◇ Low forward voltage drop
- ◇ High current capability
- ◇ Easily cleaned with Freon, Alcohol, Isopropanol and similar solvents
- ◇ The plastic material carries U/L recognition 94V-0

MECHANICAL DATA

- ◇ Case: JEDEC DO-41, molded plastic
- ◇ Terminals: Axial lead, solderable per MIL-STD-202, Method 208
- ◇ Polarity: Color band denotes cathode
- ◇ Weight: 0.012 ounces, 0.34 grams
- ◇ Mounting position: Any

DO - 41

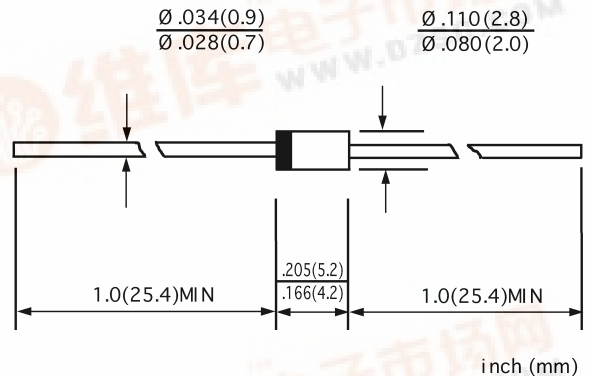

MAXIMUM RATINGS AND ELECTRICAL CHARACTERISTICS

Ratings at 25°C ambient temperature unless otherwise specified.

Single phase, half wave, 60 Hz, resistive or inductive load. For capacitive load, derate by 20%.

		ERA22 -02	ERA22 -04	ERA22 -06	ERA22 -08	ERA22 -10	UNITS
Maximum recurrent peak reverse voltage	V_{RRM}	200	400	600	800	1000	V
Maximum RMS voltage	V_{RMS}	140	280	420	560	700	V
Maximum DC blocking voltage	V_{DC}	200	400	600	800	1000	V
Maximum average forward rectified current 9.5mm lead length, @ $T_A=75^\circ C$	$I_{F(AV)}$	0.5					A
Peak forward surge current 8.3ms single half-sine-wave superimposed on rated load @ $T_J=125^\circ C$	I_{FSM}	20.0					A
Maximum instantaneous forward voltage @ 0.5 A	V_F	1.3					V
Maximum reverse current @ $T_A=25^\circ C$ at rated DC blocking voltage @ $T_A=100^\circ C$	I_R	5.0 100.0					μA
Maximum reverse recovery time (Note1)	t_{rr}	400					ns
Typical junction capacitance (Note2)	C_J	12					pF
Typical thermal resistance (Note3)	$R_{\theta JA}$	55					$^\circ C/W$
Operating junction temperature range	T_J	-55----+150					$^\circ C$
Storage temperature range	T_{STG}	-55----+150					$^\circ C$

NOTE: 1. Measured with $I_F=0.5A$, $I_R=1A$, $t_{rr}=0.25A$.

2. Measured at 1.0MHz and applied reverse voltage of 4.0V DC.

3. Thermal resistance from junction to ambient.



FIG.1 – REVERSE RECOVERY TIME CHARACTERISTIC AND TEST CIRCUIT DIAGRAM

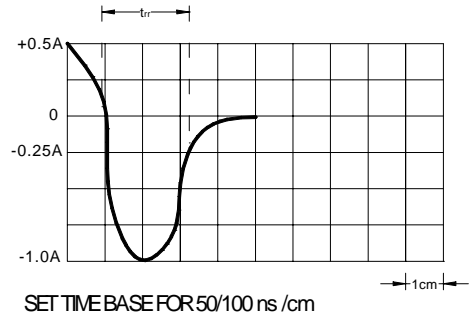
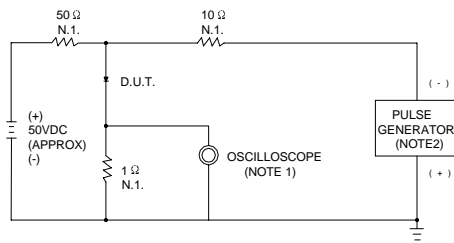

NOTES: 1. RISE TIME = 7ns MAX. INPUT IMPEDANCE = 1MΩ, 22pF
 2. RISE TIME = 10ns MAX. SOURCE IMPEDANCE = 50Ω

FIG.2- PEAK FORWARD SURGE CURRENT

PEAK FORWARD SURGE CURRENT
AMPERES

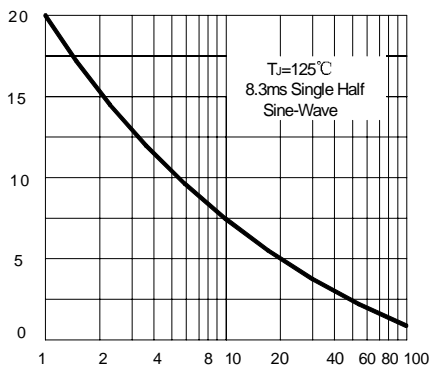

NUMBER OF CYCLES AT 60 Hz

FIG.3- FORWARD DERATING CURVE

AVERAGE FORWARD RECTIFIED CURF
CURRENT, AMPERES

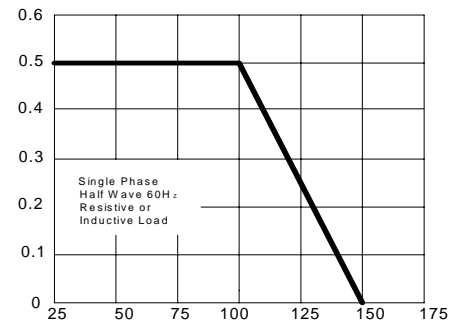

AMBIENT TEMPERATURE, °C

FIG.4 – CURRENT DERATING CURVE

INSTANTANEOUS FORWARD CURRENT
AMPERES

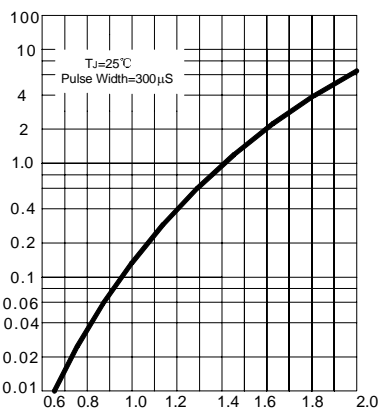

INSTANTANEOUS FORWARD VOLTAGE, VOLTS

FIG.5-TYPECAL JUNCTION CAPACITANCE

JUNCTION CAPACITANCE, pF

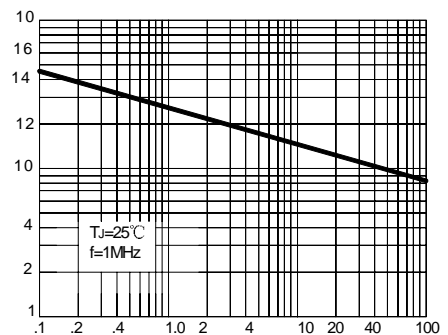

INSTANEOUS FORWARD VOLTAGE, VOLTS