

# B GALAXY ELECTRICAL ERC25-04---ERC25-06

## FAST RECOVERY RECTIFIER

VOLTAGE RANGE: 400 --- 600 V  
CURRENT: 1.2 A

### FEATURES

- ◇ Low cost
- ◇ Diffused junction
- ◇ Low leakage
- ◇ Low forward voltage drop
- ◇ High current capability
- ◇ Easily cleaned with Freon, Alcohol, Isopropanol and similar solvents
- ◇ The plastic material carries U/L recognition 94V-0

### MECHANICAL DATA

- ◇ Case: JEDEC DO-15, molded plastic
- ◇ Terminals: Axial lead, solderable per MIL-STD-202, Method 208
- ◇ Polarity: Color band denotes cathode
- ◇ Weight: 0.014 ounces, 0.39 grams
- ◇ Mounting position: Any

### DO - 15

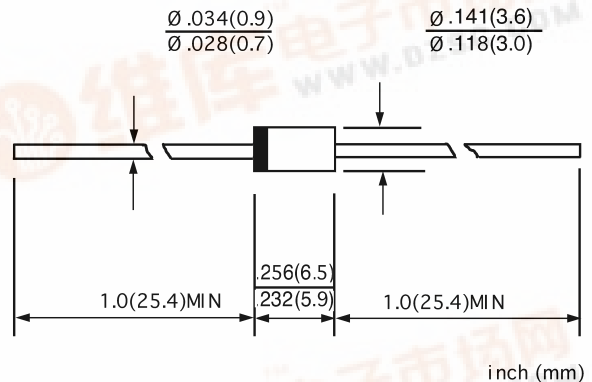

## MAXIMUM RATINGS AND ELECTRICAL CHARACTERISTICS

Ratings at 25°C ambient temperature unless otherwise specified.

Single phase, half wave, 60 Hz, resistive or inductive load. For capacitive load, derate by 20%.

		ERC25 - 04	ERC25 - 06	UNITS
Maximum recurrent peak reverse voltage	$V_{RRM}$	400	600	V
Maximum RMS voltage	$V_{RMS}$	280	420	V
Maximum DC blocking voltage	$V_{DC}$	400	600	V
Maximum average forward rectified current 9.5mm lead length, @ $T_A=75^\circ C$	$I_{F(AV)}$	1.2		A
Peak forward surge current 8.3ms single half-sine-wave superimposed on rated load @ $T_J=125^\circ C$	$I_{FSM}$	50.0		A
Maximum instantaneous forward voltage @ 1.2 A	$V_F$	1.1		V
Maximum reverse current @ $T_A=25^\circ C$ at rated DC blocking voltage @ $T_A=100^\circ C$	$I_R$	5.0 100.0		$\mu A$
Maximum reverse recovery time (Note1)	$t_{rr}$	400		ns
Typical junction capacitance (Note2)	$C_J$	18		pF
Typical thermal resistance (Note3)	$R_{\theta JA}$	45		$^\circ C/W$
Operating junction temperature range	$T_J$	-55----+150		$^\circ C$
Storage temperature range	$T_{STG}$	-55----+150		$^\circ C$

NOTE:1. Measured with  $I_F=0.5A$ ,  $I_R=1A$ ,  $I_{rr}=0.25A$ .

2. Measured at 1.0MHz and applied reverse voltage of 4.0V DC.

3. Thermal resistance from junction to ambient.

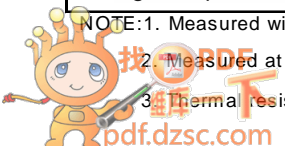

**FIG.1 – REVERSE RECOVERY TIME CHARACTERISTIC AND TEST CIRCUIT DIAGRAM**

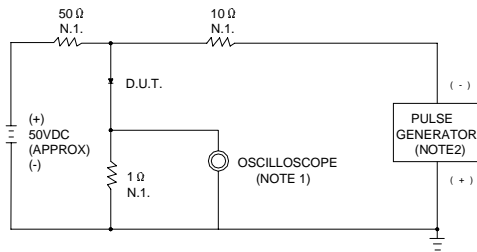

NOTES: 1. RISE TIME = 7ns MAX. INPUT IMPEDANCE = 1MΩ, 22pF  
 2. RISE TIME = 10ns MAX. SOURCE IMPEDANCE = 50Ω

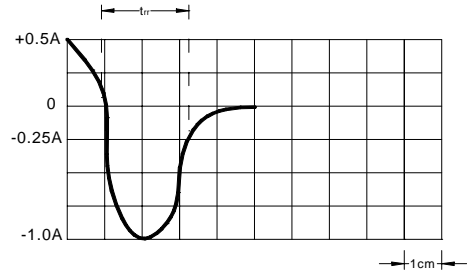

SET TIME BASE FOR 50/100 ns/cm

**FIG.2 – TYPICAL FORWARD CHARACTERISTIC**

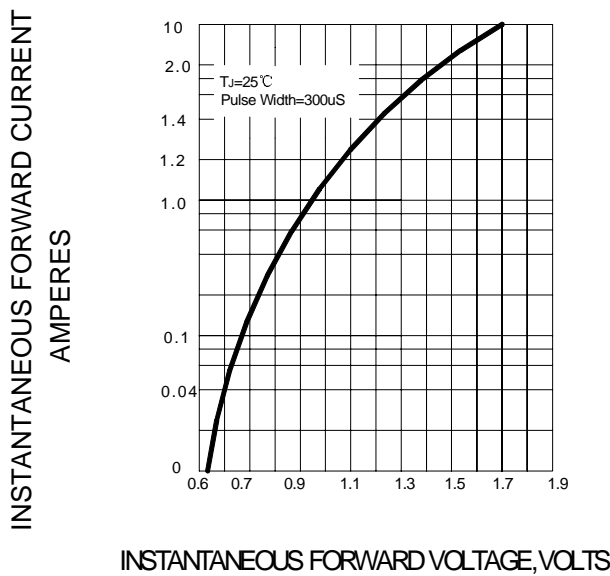

**FIG.3 – FORWARD DERATING CURVE**

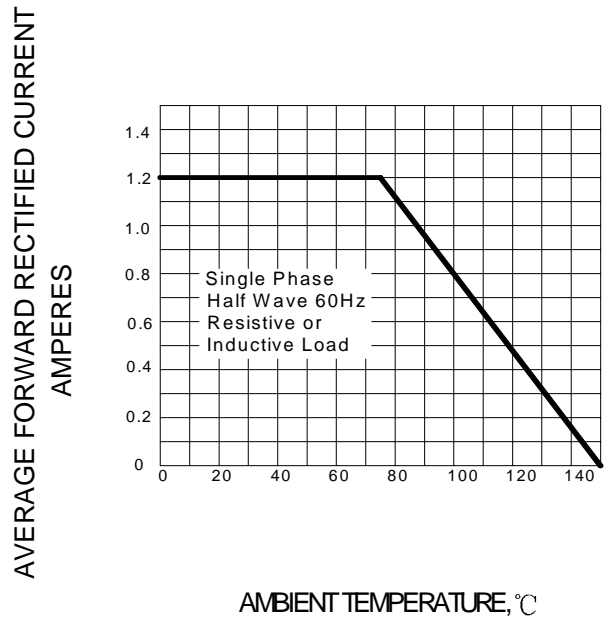

**FIG.4 – TYPICAL JUNCTION CAPACITANCE**

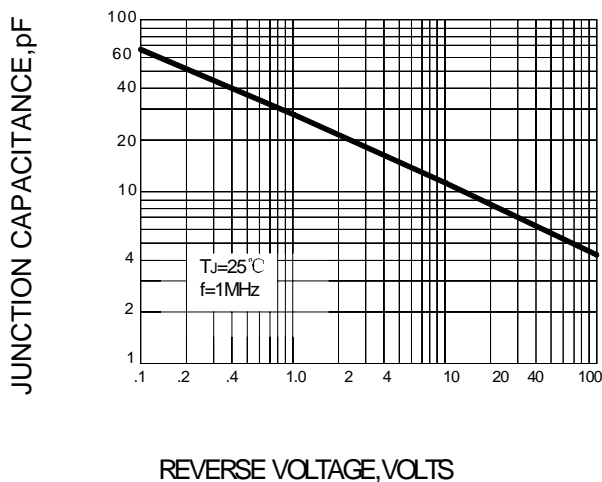

**FIG.5 – PEAK FORWARD SURGE CURRENT**

