



ESS Technology, Inc.

ES6425 Digital Media Processor 2 Product Brief

DESCRIPTION

The ES6425 Digital Media Processor 2 (DMP2) is a high performance single-chip audio/video decoder for a wide series of applications such as networked or non-networked/flash memory media players. This second generation of Digital Media Processor has an enhanced performance engine to decode MPEG-4 video at D1 resolution with state-of-the-art progressive scan NTSC/PAL video encoder for brilliant and sharp, flicker-free output to the video display.

At the heart of the ES6425 is the ESS proprietary Programmable Multimedia Processor core consisting of 32-bit RISC and 64-bit DSP processors that enable simultaneous parallel execution of system commands and specialized multimedia decoding tasks. The ES6425 includes a memory controller which interfaces to 8-bit or 16-bit DRAM with up to 128-Mb capacity.

The ES6425 performs video processing to provide high-resolution display of MPEG-1, MPEG-2, and MPEG-4 videos and JPEG photos. The integrated NTSC/PAL TV-encoder provides composite, S-video, and YUV outputs. The ES6425 includes an On-Screen-Display (OSD) controller to provide a user friendly setup menu to enable or modify the various audio decoding and video display features. A CCIR656/601 digital video output port is also present.

The ES6425 also performs audio processing for Wave, MP3, AAC, Dolby® Digital, and WMA playback along with a 7-band graphic equalizer. The ES6425 has a multi-channel audio serial port compliant to I²S format for interfacing to an external audio DAC and ADC. An S/PDIF output port is also integrated for transmitting digital audio streams.

A 16-bit host interface present in the ES6425 connects to many different storage solutions including Compact Flash®, Smart Media™, xD-Picture Card™, and IDE hard drives. Similarly, a serial interface is built-in to interface to SD™, xD™, MultiMediaCard™, and Memory Stick™ devices.

The ES6425 is available in an industry-standard 208-pin Plastic Quad Flat Pack (PQFP) device package.

FEATURES

- Single-chip digital audio and video decoder and processor.
- MPEG-4 Advanced Simple Profile* at full screen D1 video playback (playability is dependent on memory card bandwidth).
- MPEG-2 video playback (playability is dependent on memory card bandwidth).
- MPEG-1 video playback.
- Motion JPEG playback.
- JPEG photo playback.
- Progressive JPEG photo playback.
- MP3 music playback.
- WMA music playback (Microsoft license required).
- Dolby® Digital decode (ES6425FDF only)
- AAC audio decode and playback.
- ESS Music Slideshow™.
- S/PDIF digital audio output.
- Integrated NTSC/PAL encoder with pixel adaptive de-interlacer and five 10-bit 54 MHz video DACs.
- High-quality progressive scan video output for flicker-free video display.
- Simultaneous Composite, S-Video, and YUV outputs.
- CCIR656/601 YUV 4:2:2 output.
- On-Screen-Display controller with 3-bit blending to provide 256 colors display.
- Integrated I²S serial port for up to 5.1 channel audio output and stereo input.
- Direct interface for IDE devices and flash memory cards including CF, MS, MS Pro, SD, xD, MMC, and SM.
- DRAM memory controller with interface to 8-bit or 16-bit SDRAM for up to 16 MB of memory.
- 16-bit SRAM interface for connecting to boot EPROM or flash memory.
- Lead-free leads using 98%-Sn/2%-Cu or 98%-Sn/2%-Bi.



ES6425 PINOUT DIAGRAM

The device pinout for the ES6425 is shown in Figure 1. The pound symbol (#) denotes an active-low signal.

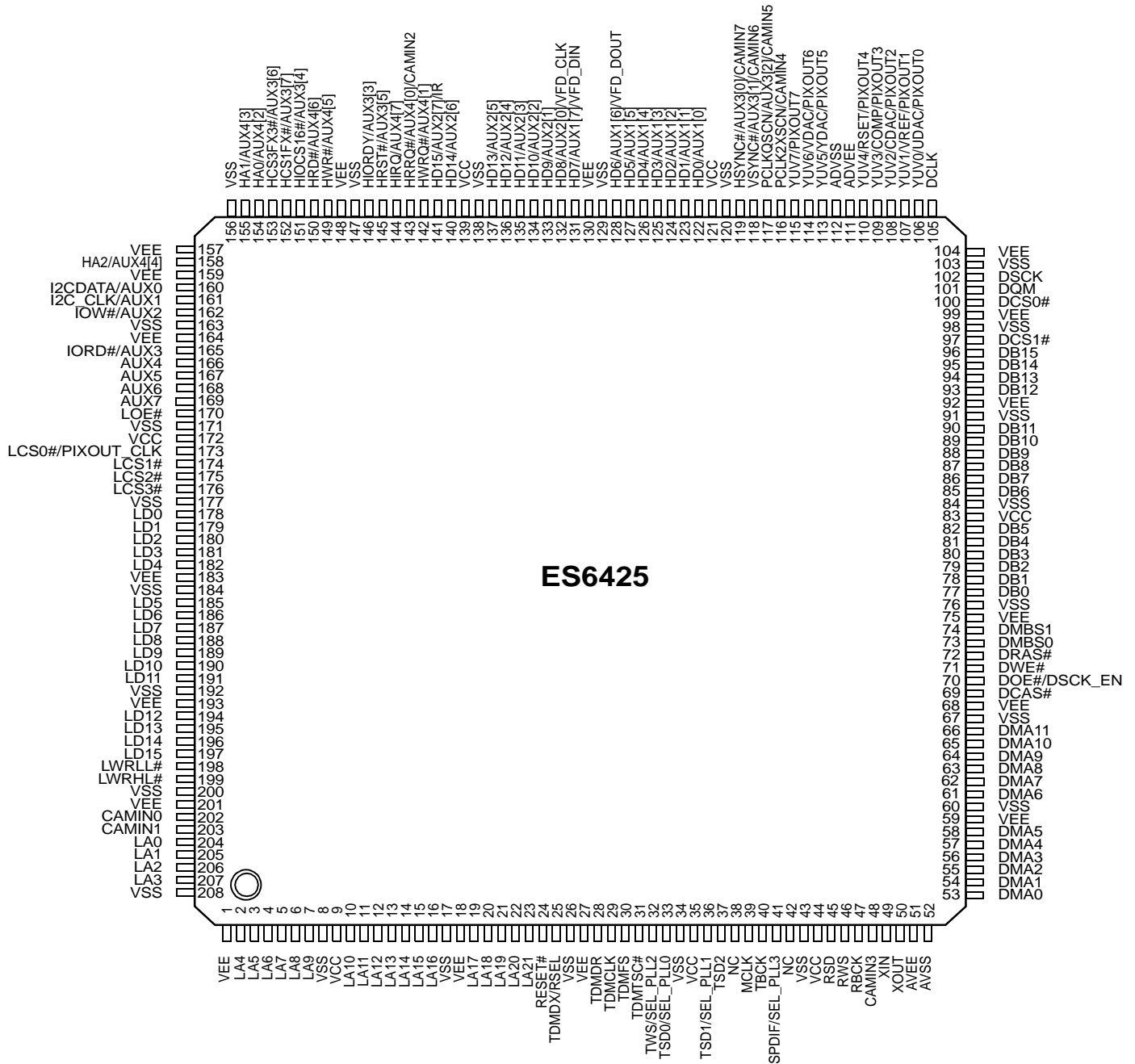

Figure 1 ES6425 Device Pinout

Note: (*) MPEG-4 Advanced Simple Profile without hardware Q-PEL and Global Motion Compensation (GMC).



ES6425 PIN DESCRIPTION

Table 1 lists the pin descriptions for the ES6425. The pound symbol (#) denotes an active-low signal.

Table 1 ES6425 Pin Description

Name	Pin Numbers	I/O	Definition																																			
VEE	1, 18, 27, 59, 68, 75, 92, 99, 104, 130, 148, 157, 159, 164, 183, 193, 201	P	I/O power supply.																																			
LA[21:0]	2-7, 10-16, 19-23, 204-207	O	RISC port address bus.																																			
VSS	8, 17, 26, 34, 43, 60, 67, 76, 84, 91, 98, 103, 120, 129, 138, 147, 156, 163, 171, 177, 184, 192, 200, 208	G	Ground.																																			
VCC	9, 35, 44, 83, 121, 139, 172	I	Core power supply.																																			
RESET#	24	I	Reset input (active-low); (5V tolerant input).																																			
TDMDX	25	O	TDM transmit data.																																			
RSEL		I	LCS3 ROM Boot Data Width Select. Strapped to VCC or ground via 4.7-kΩ resistor; read during reset. <table border="1" style="margin-left: 20px;"> <thead> <tr> <th>RSEL</th> <th>Selection</th> </tr> </thead> <tbody> <tr> <td>0</td> <td>16-bit ROM</td> </tr> <tr> <td>1</td> <td>8-bit ROM</td> </tr> </tbody> </table>	RSEL	Selection	0	16-bit ROM	1	8-bit ROM																													
RSEL	Selection																																					
0	16-bit ROM																																					
1	8-bit ROM																																					
TDMDR	28	I	TDM receive data; (5V tolerant input).																																			
TDMCLK	29	I	TDM clock; (5V tolerant input).																																			
TDMFS	30	I	TDM frame sync; (5V tolerant input).																																			
TDMTSC#	31	O	TDM output enable (active-low).																																			
TWS	32	O	Audio transmit frame sync.																																			
SEL_PLL2		I	System and DSCK output clock frequency selection is made at the rising edge of RESET#. The matrix below lists the available clock frequencies and their respective PLL bit settings. Pull up to VCC via 4.7-kΩ resistor for proper operation; read during reset. <table border="1" style="margin-left: 20px;"> <thead> <tr> <th>SEL_PLL2</th> <th>SEL_PLL1</th> <th>SEL_PLL0</th> <th>Clock Type</th> </tr> </thead> <tbody> <tr> <td>0</td> <td>0</td> <td>0</td> <td>DCLK x 4.5</td> </tr> <tr> <td>0</td> <td>0</td> <td>1</td> <td>DCLK x 5.0</td> </tr> <tr> <td>0</td> <td>1</td> <td>0</td> <td>Bypass mode</td> </tr> <tr> <td>0</td> <td>1</td> <td>1</td> <td>DCLK x 4.0</td> </tr> <tr> <td>1</td> <td>0</td> <td>0</td> <td>DCLK x 4.25</td> </tr> <tr> <td>1</td> <td>0</td> <td>1</td> <td>DCLK x 4.75</td> </tr> <tr> <td>1</td> <td>1</td> <td>0</td> <td>DCLK x 5.5</td> </tr> <tr> <td>1</td> <td>1</td> <td>1</td> <td>DCLK x 6.0</td> </tr> </tbody> </table>	SEL_PLL2	SEL_PLL1	SEL_PLL0	Clock Type	0	0	0	DCLK x 4.5	0	0	1	DCLK x 5.0	0	1	0	Bypass mode	0	1	1	DCLK x 4.0	1	0	0	DCLK x 4.25	1	0	1	DCLK x 4.75	1	1	0	DCLK x 5.5	1	1	1
SEL_PLL2	SEL_PLL1	SEL_PLL0	Clock Type																																			
0	0	0	DCLK x 4.5																																			
0	0	1	DCLK x 5.0																																			
0	1	0	Bypass mode																																			
0	1	1	DCLK x 4.0																																			
1	0	0	DCLK x 4.25																																			
1	0	1	DCLK x 4.75																																			
1	1	0	DCLK x 5.5																																			
1	1	1	DCLK x 6.0																																			
TSD0	33	O	Audio transmit serial data output 0.																																			
SEL_PLL0		I	Pull up to VCC via 4.7-kΩ resistor for proper operation; read during reset.																																			



Table 1 ES6425 Pin Description (Continued)

Name	Pin Numbers	I/O	Definition
TSD1	36	O	Audio transmit serial data output 1.
SEL_PLL1		I	Pull up to VCC via 4.7-kΩ resistor for proper operation; read during reset.
TSD2	37	O	Audio transmit serial data output 2. This pin must be pulled down to VSS via a 4.7-kΩ resistor for proper operation.
MCLK	39	I/O	Audio master clock for audio DAC.
TBCK	40	I/O	Audio transmit bit clock. TBCK is an input during reset and subsequently is programmed as an output via the AUDIOXMT register (addr 0x2000D00Ch, bit 4).
SPDIF	41	O	S/PDIF output.
SEL_PLL3		I	Pull down to ground via 4.7-kΩ resistor for proper operation; read during reset.
NC	38, 42	—	No connect.
RSD	45	I	Audio receive serial data; (5V tolerant input).
RWS	46	I	Audio receive frame sync; (5V tolerant input).
RBCK	47	I	Audio receive bit clock; (5V tolerant input).
CAMIN3	48	I	Camera and YUV input 3.
XIN	49	I	27-MHz crystal input.
XOUT	50	O	27-MHz crystal output.
AVEE	51	P	Analog power for PLL.
AVSS	52	G	Analog ground for PLL.
DMA[11:0]	53-58, 61-66	O	DRAM address bus.
DCAS#	69	O	DRAM column address strobe (active-low).
DOE#	70	O	DRAM output enable (active-low).
DSCK_EN		O	DRAM clock enable.
DWE#	71	O	DRAM write enable (active-low).
DRAS#	72	O	DRAM row address strobe (active-low).
DMBS0	73	O	SDRAM bank select 0.
DMBS1	74	O	SDRAM bank select 1.
DB[15:0]	77-82, 85-90, 93-96	I/O	DRAM data bus.
DCS[1:0]#	97,100	O	SDRAM chip select (active-low).
DQM	101	O	Data input/output mask.
DSCK	102	O	Output clock to SDRAM.
DCLK	105	I	Clock input to PLL; (5V tolerant input).



Table 1 ES6425 Pin Description (Continued)

Name	Pin Numbers	I/O	Definition																																																																											
UDAC	106	O	Video DAC output: <table border="1" style="margin-left: 20px;"> <thead> <tr> <th>Value</th> <th>DAC V (pin 114)</th> <th>DAC Y (pin 113)</th> <th>DAC C (pin 108)</th> <th>DAC U (pin 106)</th> </tr> </thead> <tbody> <tr><td>0</td><td>CVBS1</td><td>Y</td><td>N/A</td><td>C</td></tr> <tr><td>1</td><td>CVBS1</td><td>Y</td><td>CVBS2</td><td>C</td></tr> <tr><td>2</td><td>N/A</td><td>Y</td><td>N/A</td><td>C</td></tr> <tr><td>3</td><td>CVBS1</td><td>N/A</td><td>CVBS2</td><td>N/A</td></tr> <tr><td>4</td><td>CVBS1</td><td>N/A</td><td>N/A</td><td>N/A</td></tr> <tr><td>5</td><td>CVBS1</td><td>Y</td><td>Pr</td><td>Pb</td></tr> <tr><td>6</td><td>N/A</td><td>Y</td><td>Pr</td><td>Pb</td></tr> <tr><td>7</td><td>SYNC</td><td>G</td><td>R</td><td>B</td></tr> <tr><td>8</td><td>CHROMA</td><td>Y</td><td>Pr</td><td>Pb</td></tr> <tr><td>9</td><td>CVBS1</td><td>G</td><td>R</td><td>B</td></tr> <tr><td>10</td><td>CVBS1</td><td>G</td><td>B</td><td>R</td></tr> <tr><td>11</td><td>SYNC</td><td>G</td><td>B</td><td>R</td></tr> <tr><td>12</td><td>N/A</td><td>Y</td><td>Pb</td><td>Pr</td></tr> <tr><td>13</td><td>CVBS1</td><td>Y</td><td>Pb</td><td>Pr</td></tr> </tbody> </table> <p>Y: Luma component for YUV and Y/C processing. C: Chrominance signal for Y/C processing. U: Chrominance component signal for YUV mode. V: Chrominance component signal for YUV mode.</p>	Value	DAC V (pin 114)	DAC Y (pin 113)	DAC C (pin 108)	DAC U (pin 106)	0	CVBS1	Y	N/A	C	1	CVBS1	Y	CVBS2	C	2	N/A	Y	N/A	C	3	CVBS1	N/A	CVBS2	N/A	4	CVBS1	N/A	N/A	N/A	5	CVBS1	Y	Pr	Pb	6	N/A	Y	Pr	Pb	7	SYNC	G	R	B	8	CHROMA	Y	Pr	Pb	9	CVBS1	G	R	B	10	CVBS1	G	B	R	11	SYNC	G	B	R	12	N/A	Y	Pb	Pr	13	CVBS1	Y	Pb	Pr
		Value	DAC V (pin 114)	DAC Y (pin 113)	DAC C (pin 108)	DAC U (pin 106)																																																																								
		0	CVBS1	Y	N/A	C																																																																								
		1	CVBS1	Y	CVBS2	C																																																																								
		2	N/A	Y	N/A	C																																																																								
		3	CVBS1	N/A	CVBS2	N/A																																																																								
		4	CVBS1	N/A	N/A	N/A																																																																								
		5	CVBS1	Y	Pr	Pb																																																																								
		6	N/A	Y	Pr	Pb																																																																								
		7	SYNC	G	R	B																																																																								
		8	CHROMA	Y	Pr	Pb																																																																								
		9	CVBS1	G	R	B																																																																								
		10	CVBS1	G	B	R																																																																								
		11	SYNC	G	B	R																																																																								
12	N/A	Y	Pb	Pr																																																																										
13	CVBS1	Y	Pb	Pr																																																																										
YUV0		O	YUV pixel 0 output data.																																																																											
PIXOUT0		O	CCIR656 output pixel 0.																																																																											
VREF	107	I	Internal voltage reference to DAC. Bypass to ground with 0.1- μ F capacitor.																																																																											
YUV1		O	YUV pixel 1 output data.																																																																											
PIXOUT1		O	CCIR656 output pixel 1.																																																																											
CDAC	108	O	Chrominance signal for Y/C processing display.																																																																											
YUV2		O	YUV pixel 2 output data.																																																																											
PIXOUT2		O	CCIR656 output pixel 2.																																																																											
COMP	109	I	Compensation input. Bypass to ADVEE with 0.1- μ F capacitor.																																																																											
YUV3		O	YUV pixel 3 output data.																																																																											
PIXOUT3		O	CCIR656 output pixel 3.																																																																											
RSET	110	I	DAC current adjustment resistor input.																																																																											
YUV4		O	YUV pixel 4 output data.																																																																											
PIXOUT4		O	CCIR656 output pixel 4.																																																																											
ADVEE	111	P	Analog power.																																																																											
ADVSS	112	G	Analog ground for video DAC.																																																																											
YDAC	113	O	Luma component for Y/C processing display.																																																																											
YUV5		O	YUV pixel 5 output data.																																																																											
PIXOUT5		O	CCIR656 output pixel 5.																																																																											
VDAC	114	O	Video DAC output. Refer to description and matrix for UDAC pin 106.																																																																											
YUV6		O	YUV pixel 6 output data.																																																																											
PIXOUT6		O	CCIR656 output pixel 6.																																																																											



Table 1 ES6425 Pin Description (Continued)

Name	Pin Numbers	I/O	Definition
YUV7	115	O	YUV pixel 7 output data.
PIXOUT7		O	CCIR656 output pixel 7.
PCLK2XSCN	116	I/O	27-MHz video pixel clock.
CAMIN4		I	Camera and YUV input 4.
PCLKQSCN	117	O	13.5-MHz video output pixel clock.
AUX3[2]		I/O	Aux3 data I/O; (5V tolerant input).
CAMIN5		I	Camera and YUV input 5
VSYNC#	118	I/O	Vertical sync (active-low); (5V tolerant input).
AUX3[1]		I/O	Aux3 data I/O; (5V tolerant input).
CAMIN6		I	Camera and YUV input 6.
HSYNC#	119	I/O	Horizontal sync (active-low); (5V tolerant input).
AUX3[0]		I/O	Aux3 data I/O; (5V tolerant input).
CAMIN7		I	Camera and YUV input 7.
HD[5:0]	122-127	I/O	Host data bus; (5V tolerant input).
AUX1[5:0]		I/O	Aux1 data I/O; (5V tolerant input).
HD6	128	I/O	Host data bus; (5V tolerant input).
AUX1[6]		I/O	Aux1 data I/O; (5V tolerant input).
VFD_DOUT		O	VFD data output.
HD7	131	I/O	Host data bus; (5V tolerant input).
AUX1[7]		I/O	Aux1 data I/O; (5V tolerant input).
VFD_DIN		I	VFD data input.
HD8	132	I/O	Host data bus; (5V tolerant input).
AUX2[0]		I/O	Aux2 data I/O; (5V tolerant input).
VFD_CLK		I	VFD clock.
HD9	133	I/O	Host data bus; (5V tolerant input).
AUX2[1]		I/O	Aux2 data I/O; (5V tolerant input).
HD10	134	I/O	Host data bus; (5V tolerant input).
AUX2[2]		I/O	Aux2 data I/O; (5V tolerant input).
HD11	135	I/O	Host data bus; (5V tolerant input).
AUX2[3]		I/O	Aux2 data I/O; (5V tolerant input).
HD12	136	I/O	Host data bus; (5V tolerant input).
AUX2[4]		I/O	Aux2 data I/O; (5V tolerant input).
HD13	137	I/O	Host data bus; (5V tolerant input).
AUX2[5]		I/O	Aux2 data I/O; (5V tolerant input).
HD14	140	I/O	Host data bus; (5V tolerant input).
AUX2[6]		I/O	Aux2 data I/O; (5V tolerant input).
HD15	141	I/O	Host data bus; (5V tolerant input).
AUX2[7]		I/O	Aux2 data I/O 7; (5V tolerant input).
IR		I	IR remote control; (5V tolerant input).
HWRQ#	142	O	Host write request (active-low).
AUX4[1]		I/O	Aux4 data I/O 1; (5V tolerant input).

ES6425 PRODUCT BRIEF
ES6425 PIN DESCRIPTION

Table 1 ES6425 Pin Description (Continued)

Name	Pin Numbers	I/O	Definition
HRRQ#	143	O	Host read request (active-low).
AUX4[0]		I/O	Aux4 data I/O 0; (5V tolerant input).
CAMIN2		I	Camera and YUV input 2.
HIRQ	144	O	Host interrupt.
AUX4[7]		I/O	Aux4 data I/O 7; (5V tolerant input).
HRST#	145	O	Host reset (active-low).
AUX3[5]		I/O	Aux3 data I/O 5; (5V tolerant input).
HIORDY	146	I	Host I/O ready.
AUX3[3]		I/O	Aux3 data I/O 3; (5V tolerant input).
HWR#	149	O	Host write (active-low).
AUX4[5]		I/O	Aux4 data I/O 5; (5V tolerant input).
HRD#	150	O	Host read (active-low).
AUX4[6]		I/O	Aux4 data I/O 6; (5V tolerant input).
HIOCS16#	151	I	Device 16 bit data transfer (active-low).
AUX3[4]		I/O	Aux3 data I/O 4; (5V tolerant input).
CAMCLK		I	Camera and YUV port pixel clock.
HCS1FX#	152	O	Host select 1 (active-low).
AUX3[7]		I/O	Aux3 data I/O 7; (5V tolerant input).
HCS3FX#	153	O	Host select 3 (active-low).
AUX3[6]		I/O	Aux3 data I/O 6; (5V tolerant input).
HA[2:0]	154, 155, 158	I/O	Host address bus.
AUX4[4:2]		I/O	Aux4 data I/Os 2, 3, and 4; (5V tolerant input).
AUX0	160	I/O	Auxiliary port 0 (open collector); (5V tolerant input).
I2CDATA		I/O	I ² C data I/O; (5V tolerant input).
AUX1	161	I/O	Auxiliary port 1 (open collector); (5V tolerant input).
I2C_CLK		I/O	I ² C clock I/O; (5V tolerant input).
IOW#	162	O	I/O write strobe (LCS1) (active-low).
AUX2		I/O	Auxiliary port 2; (5V tolerant input).
IOR#	165	O	I/O read strobe (LCS1) (active-low).
AUX3		I/O	Auxiliary port 3; (5V tolerant input).
AUX4-7	166-169	I/O	Auxiliary ports 4-7; (5V tolerant input).
LOE#	170	O	RISC port output enable (active-low).
LCS0#	173	O	RISC port chip select 0 (active-low).
PIXOUT_CLK		O	CCIR656 output pixel clock.
LCS[3:1]#	174-176	O	RISC port chip select [3:1] (active-low).
LD[15:0]	178-182, 185-191, 194-197	I/O	RISC port data bus; (5V tolerant input).
LWRLL#	198	O	RISC port low-byte write enable (active-low).
LWRHL#	199	O	RISC port high-byte write enable (active-low).
CAMIN0	202	I	Camera and YUV input 0.
CAMIN1	203	I	Camera and YUV input 1.

SYSTEM BLOCK DIAGRAM

A sample system block diagram for the ES6425 board design is shown in Figure 2.

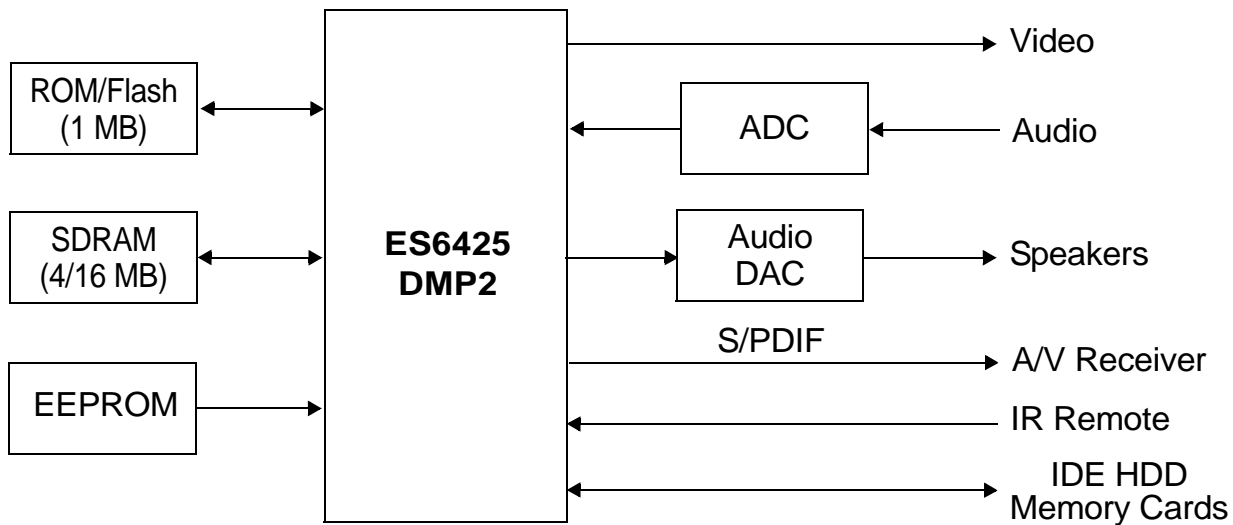

Figure 2 ES6425 System Block Diagram

ORDERING INFORMATION

Part Number	Description	Package
ES6425FF	Digital Media Processor 2 with lead-free leads.	208-pin PQFP
ES6425FDF	Digital Media Processor 2 with Dolby Digital support and lead-free leads.	208-pin PQFP

The letter F at the end of the part number identifies the package type PQFP.

The second letter F at the end of the part number indicates lead-free leads with the device.



ESS Technology, Inc.
48401 Fremont Blvd.
Fremont, CA 94538
Tel: (510) 492-1088
Fax: (510) 492-1898

No part of this publication may be reproduced, stored in a retrieval system, transmitted, or translated in any form or by any means, electronic, mechanical, manual, optical, or otherwise, without the prior written permission of ESS Technology, Inc.

ESS Technology, Inc. makes no representations or warranties regarding the content of this document.

All specifications are subject to change without prior notice.

ESS Technology, Inc. assumes no responsibility for any errors contained herein.

U.S. patents pending.

MPEG is the Moving Picture Experts Group of the ISO/IEC. References to MPEG in this document refer to the ISO/IEC JTC1 SC29 committee draft ISO 11172 dated January 9, 1992.

Vibratto, SmartBright, SmartLogo, SmartColor, and Music Slideshow are trademarks of ESS Technology, Inc.

Dolby is a trademark of Dolby Laboratories, Inc.

Trusurround, Trusurround XT, SRS, and (o) symbol are trademarks of SRS Labs., Inc.

All other trademarks are trademarks of their respective companies and are used for identification purposes only.