



查询ET-T1465供应商

6DA4-12D4-17D4 请各邦 专业的PCB打样工厂, 24小时加急出货

6DA4
12D4
17D4
ET-T1465
Page 1
4-57

DIODE

FOR TV DAMPING DIODE APPLICATIONS

DESCRIPTION AND RATING

The 6DA4 is a single heater-cathode type diode for service as the damping diode in the horizontal-deflection circuit of television receivers. It will withstand high pulse voltages between the heater and cathode and high inverse pulse voltages between the plate and cathode. These characteristics make the tube particularly useful in autotransformer deflection systems where high pulse voltages are applied to the cathode of the damper tube.

Except for heater ratings, the 12D4 and 17D4 are identical to the 6DA4. In addition, the 12D4 and 17D4 incorporate a controlled heater-warm-up characteristic which makes them especially suited for use in television receivers with series-connected heaters.

GENERAL

ELECTRICAL

	6DA4	12D4	17D4	
Cathode—Coated Unipotential				
Heater Voltage, AC or DC	6.3	12.6	16.8	Volts
Heater Current	1.2	0.6	0.45	Amperes
Heater Warm-up Time*		11	11	Seconds
Direct Interelectrode Capacitances, approximate†				
Cathode to Plate and Heater			8.0	μmf
Plate to Cathode and Heater			6.0	μmf
Heater to Cathode			3.0	μmf

MECHANICAL

Mounting Position—Any
Envelope—T-9, Glass
Base—B5-82 or B6-8, Intermediate-Shell Octal
or B5-85 or B6-60, Short Intermediate-Shell Octal

BASING DIAGRAM

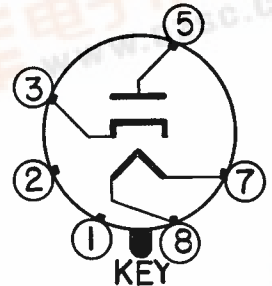

EIA 4CG

TERMINAL CONNECTIONS

Pin 1—Internal Connection†
Pin 2—Internal Connection
Pin 3—Cathode
Pin 5—Plate
Pin 7—Heater
Pin 8—Heater

† Pin 1 omitted on B5-82 and B5-85 bases.

Socket terminals 1, 2, 4, and 6 should not be used.

PHYSICAL DIMENSIONS

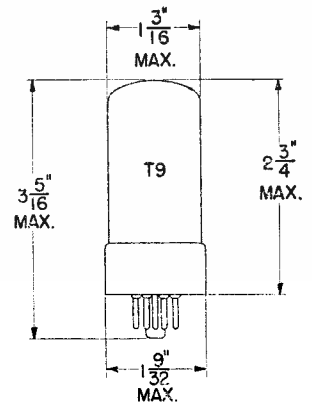

EIA 9-11

MAXIMUM RATINGS

TV DAMPER SERVICE§

DESIGN-MAXIMUM VALUES

Peak Inverse Plate Voltage	4400	Volts
Plate Dissipation	5.5	Watts
Steady-State Peak Plate Current	900	Milliamperes
DC Output Current	155	Milliamperes
Heater-Cathode Voltage		
Heater Positive with Respect to Cathode		
DC Component	100	Volts
Total DC and Peak	300	Volts
Heater Negative with Respect to Cathode		
DC Component	900	Volts
Total DC and Peak	4400	Volts

Design-Maximum Ratings are the limiting values expressed with respect to bogie tubes at which satisfactory tube life can be expected to occur for the types of service for which the tube is rated. Therefore, the equipment designer must establish the circuit design so that initially and throughout equipment life no design-maximum value is exceeded with a bogie tube under the worst probable operating conditions with respect to supply-voltage variation, equipment component variation, equipment control adjustment, load variation, and environmental conditions.

AVERAGE CHARACTERISTICS

Tube Voltage Drop		
$I_b = 250$ Milliamperes DC	22	Volts

* The time required for the voltage across the heater to reach 80 percent of its rated value after applying 4 times rated heater voltage to a circuit consisting of the tube heater in series with a resistance equal to 3 times the rated heater voltage divided by the rated heater current.

† Without external shield.

§ For operation in a 525-line, 30-frame television system as described in "Standards of Good Engineering Practice Concerning Television Broadcast Stations," Federal Communications Commission. The duty cycle of the voltage pulse must not exceed 15 percent of one scanning cycle.

Operation of this tube as a power rectifier is not recommended.

AVERAGE PLATE CHARACTERISTICS

