



**EUTECH**  
MICROELECTRONICS

*EUP8020X*

# Dual Source AC/USB Li-Ion/Polymer Charger IC for Portable Applications

## DESCRIPTION

The EUP8020X series are highly integrated single cell Li-Ion/Polymer battery charger IC designed for handheld devices. The EUP8020X accepts two power inputs, normally one from a USB port and another one from AC-adaptor. The EUP8020X automatically selects the USB-Port or the AC-adaptor as the power source for the system. In the USB configuration, the host can select from the two preset charge rates of 100 mA and 500 mA. In the AC-adaptor configuration an external resistor sets the magnitude of the charge current, which may be programmed up to 1A.

The EUP8020X charges the battery in three phases: conditioning, constant current, and constant voltage. Charge is terminated based on minimum current. An internal charge timer provides a backup safety for charge termination. The EUP8020X automatically re-starts the charge if the battery voltage falls below an internal threshold. The EUP8020X also automatically enters sleep mode when both supplies are removed. No external sense resistor or blocking diode is required for charging.

The EUP8020X integrates internal power FET, current sensor, charge status and reverse current protection in a single monolithic devices.

## FEATURES

- Charges Single Cell Li-Ion/Polymer from Either AC Adapter or USB With Autonomous Power-Source Selection
- Integrated Power FET and Current Sensor for Up to 1A Charge Applications From AC Adapter
- Integrated USB Control With Selectable 100 mA and 500 mA Charge Rates
- Precharge Conditioning With Safety Timer
- Power Good (AC Adapter Present) Status Output
- Optional Battery Temperature Monitoring Before and During Charge
- Automatic Sleep Mode for Low-Power Consumption
- Available in TDFN-10 Package
- RoHS Compliant and 100% Lead (Pb)-Free

## APPLICATIONS

- Smartphones
- Digital Cameras
- PDAs/ MP3 Players
- Other Battery-Powered Devices

## Typical Application Circuit

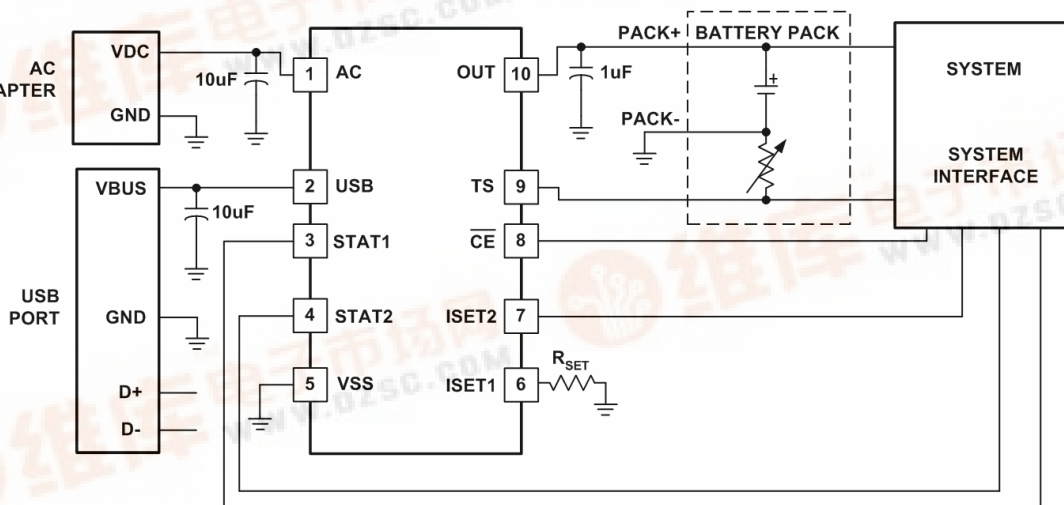

Figure 1. EUP8020A



Block Diagram

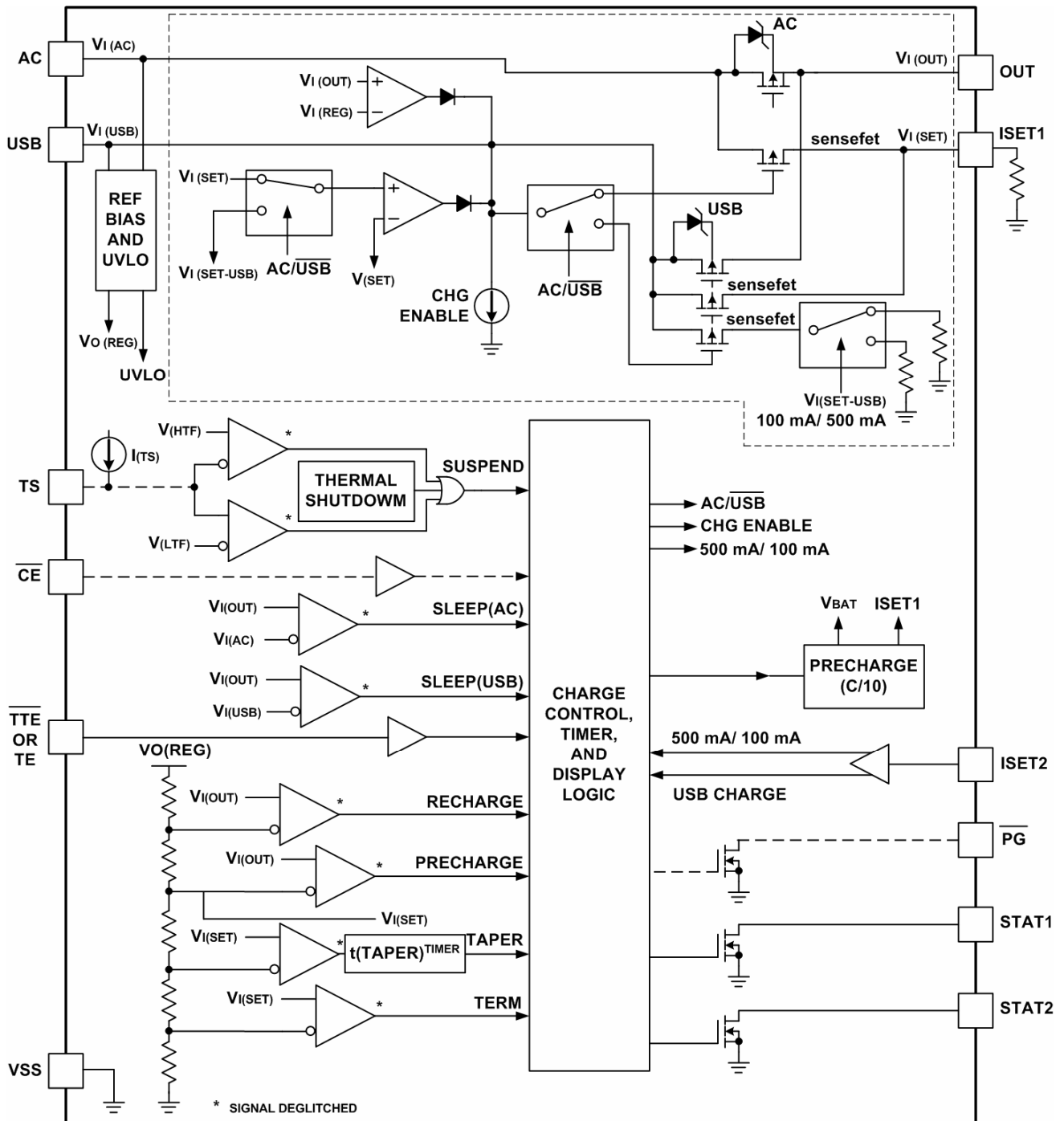

Figure 2.

## Pin Configurations

Package Type	Pin Configurations	Package Type	Pin Configurations
EUP8020A/E TDFN-10		EUP8020B TDFN-10	
EUP8020C TDFN-10		EUP8020D TDFN-10	
EUP8020F TDFN-10		EUP8020G TDFN-10	

## Pin Description

PIN	A,E	B	C	D	F	G	I/O	DESCRIPTION
AC	1	1	1	1	1	1	I	AC charge input voltage
USB	2	2	2	2	2	2	I	USB charge input voltage
STAT1	3	3	3	3	3	7	O	Charge status output 1 (open-drain)
STAT2	4	4	4	4	4	6	O	Charge status output 2 (open-drain)
VSS	5	5	5	5	5	3	-	Ground input
ISET1	6	6	6	6	6	8	I	Charge current set point for AC input and precharge and taper set point for both AC and USB
ISET2	7	7	7	7	7	4	I	Charge current set point for USB port (high=500 mA, Low=100 mA, hi-z=disable USB charge)
$\overline{CE}$	8	9	8	-	-	5	I	Charge enable input (active low)
TS	9	-	-	9	9	9	I	Temperature sense input
OUT	10	10	10	10	10	10	O	Charge current output
$\overline{PG}$	-	8	-	-	-	-	O	Powergood status output (active low)
$\overline{TE}$	-	-	-	-	8	-	I	Timer enable input (active low)
$\overline{TTE}$	-	-	9	8	-	-	I	Timer and termination enable input (active low)

## Ordering Information

Order Number	Package Type	Marking	Operating Temperature range
EUP8020A-JIR1	TDFN-10	XXXXX 8020A	-20 °C to 70°C
EUP8020B-JIR1	TDFN-10	XXXXX 8020B	-20 °C to 70°C
EUP8020C-JIR1	TDFN-10	XXXXX 8020C	-20 °C to 70°C
EUP8020D-JIR1	TDFN-10	XXXXX 8020D	-20 °C to 70°C
EUP8020E-JIR1	TDFN-10	XXXXX 8020E	-20 °C to 70°C
EUP8020F-JIR1	TDFN-10	XXXXX 8020F	-20 °C to 70°C
EUP8020G-JIR1	TDFN-10	XXXXX 8020G	-20 °C to 70°C

EUP8020X-

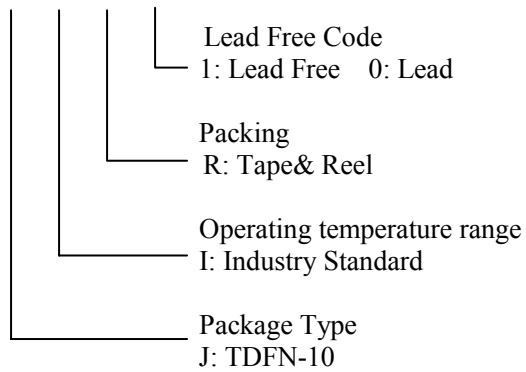

## Absolute Maximum Ratings

- Input voltage(AC,  $\overline{CE}$ , ISET1, ISET2, OUT,  $\overline{PG}$ , STAT1, STAT2,  $\overline{TE}$ , TS,  $\overline{TTE}$ , USB) ----- 0.3V to 6V
- Output sink / source current (STAT1, STAT2,  $\overline{PG}$ ) ----- 15mA
- Output current (TS) ----- 200  $\mu$  A
- Output current (OUT) ----- 1.5 A
- Junction temperature range,  $T_J$  ----- 150°C
- Storage temperature range,  $T_{stg}$  ----- -65°C to 150°C
- Lead temperature (soldering, 10s) ----- 260°C

## Dissipation Ratings

Package	JA	$T_A < 40^\circ\text{C}$ Power Rating	Derating Factor Above $T_A = 25^\circ\text{C}$
TDFN-10	48°C/W	1.5W	0.0208 W/°C

## Recommended Operating Conditions (1)

	Min.	Max.	Unit
Supply voltage (from AC input), $V_{CC}$	4.5	5.5	V
Supply voltage (from USB input), $V_{CC}$	4.35	5.5	V
Operating junction temperature range, $T_J$	-40	125	°C

## Electrical Characteristics over Recommended Operating Free-Air Temperature Range

Parameter	Conditions	EUP8020X			Unit
		Min.	Typ.	Max.	
<b>Input Current</b>					
VCC current, $I_{CC}(V_{CC})$	$V_{CC} > V_{CC}(\text{min})$		0.9	1.5	mA
Sleep current, $I_{CC}(\text{SLP})$	Sum of currents into OUT pin, $V_{CC} < V_{(\text{SLP})}$		1	5	$\mu$ A
Standby current, $I_{CC}(\text{STBY})$	$\overline{CE} = \text{High}, 0^\circ\text{C} \leq T_J \leq 85^\circ\text{C}$		50	150	
<b>Voltage Regulation</b>					
Output voltage, $V_{O(\text{REG})}$			4.2		V
Voltage regulation accuracy	$T_A = 25^\circ\text{C}$		-0.5%	0.5%	
			-1.5%	1.5%	
AC dropout voltage ( $V_{(\text{AC})} - V_{(\text{OUT})}$ ), $V_{(\text{DO})}$	$V_{O(\text{OUT})} = V_{O(\text{REG})}, I_{O(\text{OUT})} = 1\text{A}$		400	500	mV
USB dropout voltage ( $V_{(\text{USB})} - V_{(\text{OUT})}$ ), $V_{(\text{DO})}$	$V_{O(\text{OUT})} = V_{O(\text{REG})}$ ISET2 = High		400	500	
		$V_{O(\text{OUT})} = V_{O(\text{REG})}$ ISET2 = Low		100	150

## Electrical Characteristics Over Recommended Operating Free-Air Temperature Range

Parameter	Conditions	EUP8020X			Unit
		Min.	Typ.	Max.	
<b>Current Regulation</b>					
AC output current range, $I_{O(OUT)}$ (1)	$V_{I(OUT)} > V_{(LOWV)}$ , $V_{CC} \geq 4.5$ V	50		1000	mA
USB output current range, $I_{O(OUT)}$	$V_{I(OUT)} > V_{(LOWV)}$ , $V_{CC} \geq 4.5$ V ISET2 = Low	80		100	
	$V_{I(OUT)} > V_{(LOWV)}$ , $V_{CC} \geq 4.5$ V ISET2 = High	400		500	
Output current set voltage, $V_{(SET)}$	Voltage on ISET1 pin, $V_{CC} \geq 4.5$ V, $V_{I(OUT)} > V_{(LOWV)}$	2.410	2.460	2.510	V
Output current set factor, $K_{(SET)}$	$50$ mA $\leq I_{O(OUT)} \leq 1$ A	304	320	336	
	$10$ mA $\leq I_{O(OUT)} < 50$ mA	294	320	346	
	$1$ mA $\leq I_{O(OUT)} < 10$ mA	246	320	416	
<b>Precharge and Short-Circuit Current Regulation</b>					
Precharge to fast-charge transition threshold, $V_{(LOWV)}$	Voltage on OUT pin	2.8	3.0	3.2	V
Deglitch time for fast-charge to precharge transition		250	375	500	ms
Precharge range, $I_{O(PRECHG)}$ (2)	$0$ V $< V_{I(OUT)} < V_{(LOWV)}$	5		100	mA
Precharge set voltage, $V_{(PRECHG)}$	Voltage on ISET1 pin, $0$ V $< V_{I(OUT)} > V_{(LOWV)}$	230	245	260	mV
<b>Charge Taper and Termination Detection</b>					
Charge taper detection range, $I_{(TAPER)}$ (3)	$V_{I(OUT)} > V_{(RCH)}$	5		100	mA
USB-100 charge taper detection level 8020F	$V_{I(OUT)} > V_{(RCH)}$ , ISET2 = Low	6.5	9	11	
USB-500 charge taper detection level 8020F	$V_{I(OUT)} > V_{(RCH)}$ , ISET2 = High	32	44	55	
Charge taper detection set voltage, $V_{(TAPER)}$	Voltage on ISET1 pin, $V_{O(REG)} = 4.2$ V, $V_{I(OUT)} > V_{(RCH)}$	235	250	265	mV
Charge termination detection set voltage, $V_{(TERM)}$ (4)	Voltage on ISET pin, $V_{O(REG)} = 4.2$ V, $V_{I(OUT)} > V_{(RCH)}$	11	18	25	
Deglitch time for TAPER detection, $t_{TPRDET}$		250	375	500	ms
Deglitch time for termination detection, $t_{TRMDET}$		250	375	500	
<b>Temperature Sense Comparator</b>					
Low-voltage threshold, $V_{(LTF)}$		2.49	2.515	2.54	V
High-voltage threshold, $V_{(HTF)}$		0.495	0.510	0.525	
Current source, $I_{(TS)}$		102	112	122	$\mu$ A
Deglitch time for temperature fault, $t_{(DEGL)}$		250	375	500	ms

$$(1) I_{O(OUT)} = \left( \frac{K_{(SET)} \times V_{(SET)}}{R_{SET}} \right)$$

$$(2) I_{O(PRECHG)} = \left( \frac{K_{(SET)} \times V_{(PRECHG)}}{R_{SET}} \right)$$

Parameter	Conditions	EUP8020X			Unit
		Min.	Typ.	Max.	
<b>Battery Recharge Threshold</b>					
Recharge threshold, VRCH		V <sub>O(REG)</sub> -0.150	V <sub>O(REG)</sub> -0.10	V <sub>O(REG)</sub> -0.050	V
Deglitch time for recharge detect, t(DEGL)		250	375	500	ms
<b>STAT1, STAT2, and PG Outputs</b>					
Low-level output saturation voltage, V <sub>OL</sub>	I <sub>O</sub> = 5 mA			0.25	V
<b>ISSET2, Charge Enable (CE), Timer and Termination Enable (TTE), and Timer Enable (TE) Inputs</b>					
Low-level input voltage, V <sub>IL</sub>	I <sub>IL</sub> = 10 μA	0		0.4	V
High-level input voltage, V <sub>IH</sub>	I <sub>IL</sub> = 20 μA	1.4			
CE, TE or TTE low-level input current, I <sub>IL</sub>		-1			μA
CE, TE or TTE high-level input current, I <sub>IH</sub>				1	
ISSET2 low-level input current, I <sub>IL</sub>	I <sub>ISSET2</sub> = 0	-20			
ISSET2 high-level input current, I <sub>IH</sub>	I <sub>ISSET2</sub> = V <sub>CC</sub>			40	
ISSET2 high-Z input current, I <sub>IH</sub>				1	V
<b>Timers</b>					
Precharge time, t <sub>(PRECHG)</sub>		1,650	1,940	2,230	s
Taper time, t <sub>(TAPER)</sub>	8020A,8020B,8020C,8020D, 8020E,8020G	1,650	1,940	2,230	
Charge time, t <sub>(CHG)</sub>	8020A,8020B,8020C,8020D,8020G	16,500	19,400	22,300	
	8020E,8020F	23,080	27,160	31,235	s
Timer fault recovery current, I <sub>(FAULT)</sub>			200		μA
<b>Sleep Comparator</b>					
Sleep-mode entry threshold voltage, V <sub>(SLP)</sub>	2.3 V ≤ V <sub>I(OUT)</sub> ≤ V <sub>O(REG)</sub>	V <sub>CC</sub> ≤ V <sub>I(OUT)</sub> +100 mV			V
Sleep mode exit threshold voltage, V <sub>(SLPEXIT)</sub>	2.3 V ≤ V <sub>I(OUT)</sub> ≤ V <sub>O(REG)</sub>	V <sub>CC</sub> ≥ V <sub>I(OUT)</sub> +190mV			
Sleep mode deglitch time		250	375	500	ms
<b>Thermal Shutdown Thresholds</b>					
Thermal trip threshold, T <sub>(SHTDWN)</sub>			165		°C
Thermal hysteresis			30		
<b>Undervoltage Lockout</b>					
Undervoltage lockout V <sub>(UVLO)</sub>	Decreasing V <sub>CC</sub>	2.2	2.4	2.6	V
Hysteresis			20		mV

$$(3) I_{O(TAPER)} = \left( \frac{K_{(SET)} \times V_{(TAPER)}}{R_{SET}} \right)$$

$$(4) I_{O(TERM)} = \left( \frac{K_{(SET)} \times V_{(TERM)}}{R_{SET}} \right)$$

Application Information

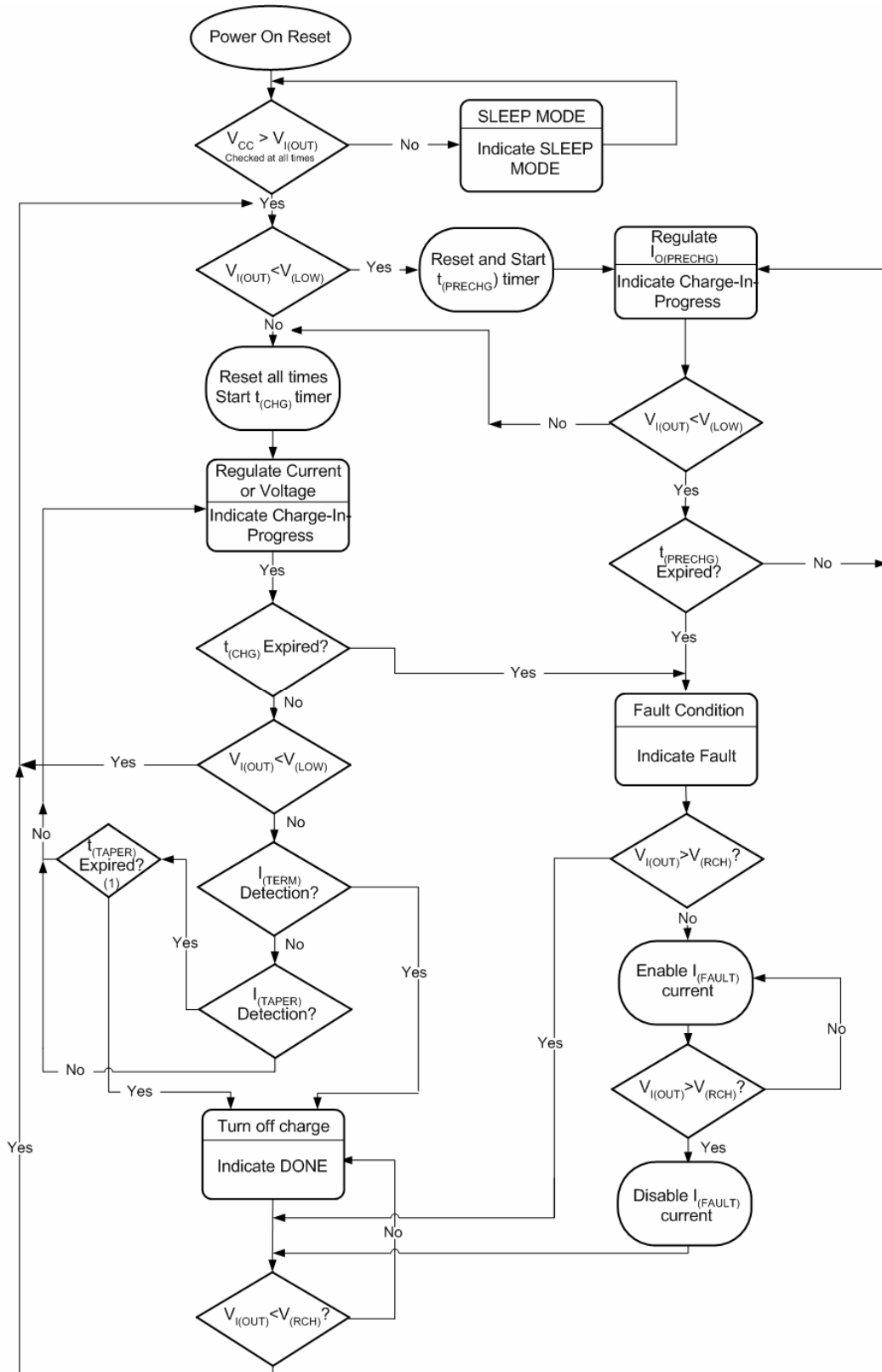

Figure 3. Operational Flow Chart



## Functional Description

### Autonomous Power Source Selection

As default the EUP8020X attempts to charge from the AC input. If AC input is not present, the USB is selected. If both inputs are available, the AC adapter has the priority. See Figure 4 for details.

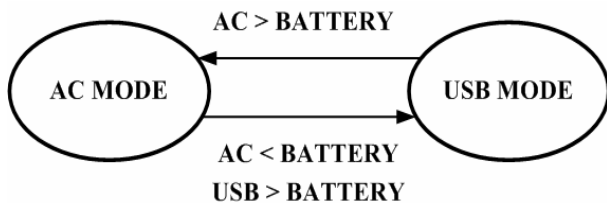

Figure 4. Typical Charging Profile

### Temperature Qualification

(8020A,8020D,8020E,8020F,8020G Only)

The EUP8020X continuously monitors battery temperature by measuring the voltage between the TS and VSS pins.

An internal current source provides the bias for most common 10-k negative-temperature coefficient thermistors (NTC) (see Figure 5). The device compares the voltage on the TS pin against the internal  $V_{(LTF)}$  and  $V_{(HTF)}$  thresholds to determine if charging is allowed. Once a temperature outside the  $V_{(LTF)}$  and  $V_{(HTF)}$  thresholds is detected the device immediately suspend the charge. The device suspend charge by turning off the power FET and holding the timer value (i.e. timers are NOT reset). Charge is resumed when the temperature returns to the normal range.

However the user may modify these thresholds by adding two external resistors. See Figure 6.

### Battery Pre-Conditioning

During a charge cycle if the battery voltage is below the  $V_{(LOWV)}$  threshold, the EUP8020X applies a precharge current,  $I_{O(PRECHG)}$ , to the battery. This feature revives deeply discharged cells. The resistor connected between the ISET1 and  $V_{SS}$ ,  $R_{SET}$ , determines the precharge rate. The  $V_{(PRECHG)}$  and  $K_{(SET)}$  parameters are specified in the specifications table. Note that this applies to both AC and USB charging.

$$I_{O(PRECHG)} = \frac{V_{(PRECHG)} \times K_{(SET)}}{R_{SET}} \quad \text{----- (1)}$$

The EUP8020X activates a safety timer,  $t_{(PRECHG)}$ , during the conditioning phase. If  $V_{(LOWV)}$  threshold is not reached within the timer period, the EUP8020X turns off the charger and enunciates FAULT on the STATx pins. Please refer to the Timer Fault Recovery section for additional details.

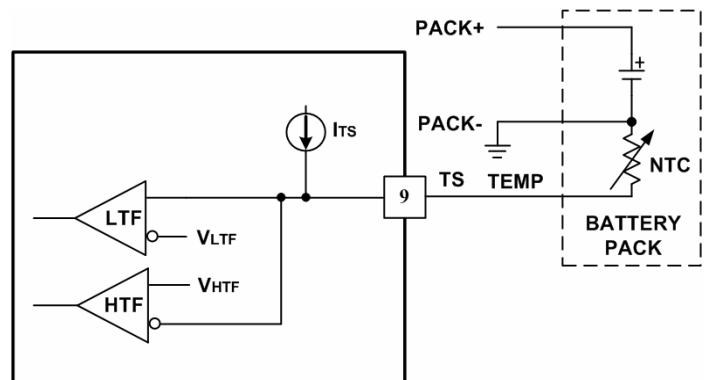

Figure 5. Temperature Sensing Configuration

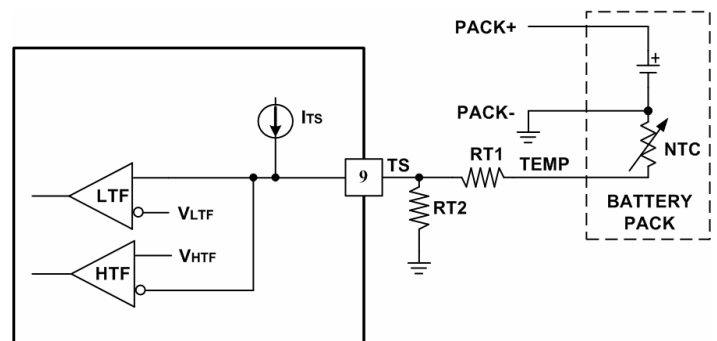

Figure 6. Temperature Sensing Thresholds

### Battery Charge Current

The EUP8020X offers on-chip current regulation with programmable set point. The resistor connected between the ISET1 and  $V_{SS}$ ,  $R_{SET}$ , determines the AC charge rate. The  $V_{(SET)}$  and  $K_{(SET)}$  parameters are specified in the specifications table.

$$I_{O(OUT)} = \frac{V_{(SET)} \times K_{(SET)}}{R_{SET}} \quad \text{----- (2)}$$

When charging from a USB port, the host controller has the option of selecting either 100 mA or 500 mA charge rate using ISET2 pin. A low-level signal sets current at 100 mA and a high level signal sets current at 500 mA. A high-Z input disables USB charging.

## Battery Voltage Regulation

The voltage regulation feedback is through the OUT pin. This input is tied directly to the positive side of the battery pack. The EUP8020X monitors the battery pack voltage between the OUT and VSS pins. When the battery voltage rises to  $V_{O(REG)}$  threshold, the voltage regulation phase begins and the charging current begins to taper down.

As a safety backup, the EUP8020X also monitors the charge time in the charge mode. If charge is not terminated within this time period,  $t_{(CHG)}$ , the EUP8020X turns off the charger and enunciates FAULT on the STATx pins. Please refer to the Timer Fault Recovery section for additional details.

## Charge Taper Detection, Termination and Recharge

The EUP8020X monitors the charging current during the voltage regulation phase. Once the taper threshold,  $I_{(TAPER)}$ , is detected the EUP8020X initiates the taper timer,  $t_{(TAPER)}$ . Charge is terminated after the timer expires. The resistor connected between the ISET1 and VSS,  $R_{SET}$ , determines the taper detection level. The  $V_{(TAPER)}$  and  $K_{(SET)}$  parameters are specified in the specifications table. Note that this applies to both AC and USB charging.

$$I_{(TAPER)} = \frac{V_{(TAPER)} \times K_{(SET)}}{R_{SET}} \text{----- (3)}$$

The EUP8020X resets the taper timer in the event that the charge current returns above the taper threshold,  $I_{(TAPER)}$ .

In addition to the taper current detection, the EUP8020X terminates charge in the event that the charge current falls below the  $I_{(TERM)}$  threshold. This feature allows for quick recognition of a battery removal condition or insertion of a fully charged battery. Note that charge timer and taper timer are bypassed for this feature. The resistor connected between the ISET1 and VSS,  $R_{SET}$ , determines the taper detection level. The  $V_{(TERM)}$  and  $K_{(SET)}$  parameters are specified in the specifications table. Note that this applies to both AC and USB charging.

$$I_{(TERM)} = \frac{V_{(TERM)} \times K_{(SET)}}{R_{SET}} \text{----- (4)}$$

After charge termination, the EUP8020X re-starts the charge once the voltage on the OUT pin falls below the  $V_{(RCH)}$  threshold. This feature keeps the battery at full capacity at all times.

## Note On EUP8020F

The EUP8020F monitors the charging current during the voltage regulation phase. Once the taper threshold,  $I_{(TAPER)}$ , is detected the EUP8020F terminates the charge. There is no taper timer,  $t_{(TAPER)}$  for this version.

The resistor connected between the ISET1 and VSS,  $R_{SET}$ , determines the taper detection level for AC input. For USB charge, taper level is fixed at 10% of the 100- or 500-mA charge rate.

Also note that there is  $I_{(TERM)}$  detection in EUP8020F.

## Sleep Mode

The EUP8020X enters the low-power sleep mode if both AC and USB are removed from the circuit. This feature prevents draining the battery during the absence of input supply.

## Charge Status Outputs

The open-drain STAT1 and STAT2 outputs indicate various charger operations as shown in the following table. These status pins can be used to drive LEDs or communicate to the host processor. Note that OFF indicates the open-drain transistor is turned off.

Table 1. Status Pins Summary

CHARGE STATE	STAT1	STAT2
Precharge in progress	ON	ON
Fast charge in progress	ON	OFF
Charge done	OFF	ON
Charge suspend (temperature)	OFF	OFF
Timer fault	OFF	OFF
Sleep mode	OFF	OFF

OFF means the open-drain output transistor on the STAT1 and STAT2 pins is in an off state.

## PG Output

The open-drain  $\overline{PG}$  (Power Good) indicates when the AC adapter is present. The output turns ON when a valid voltage is detected. This output is turned off in the sleep mode. The  $\overline{PG}$  pin can be used to drive an LED or communicate to the host processor.

## $\overline{\text{CE}}$ Input (Charge Enable)

The  $\overline{\text{CE}}$  digital input is used to disable or enable the charge process. A low-level signal on this pin enables the charge and a high-level signal disables the charge and places the device in a low-power mode. A high-to-low transition on this pin also resets all timers and timer fault conditions. Note that this applies to both AC and USB charging.

## $\overline{\text{TTE}}$ Input (Timer and Termination Enable)

The  $\overline{\text{TTE}}$  digital input is used to disable or enable the fast-charge timer and charge taper detection. A low-level signal on this pin enables the fast-charge timer and taper timer and a high-level signal disables this feature. Note that this applies to both AC and USB charging.

## Thermal shutdown and Protection

The EUP8020X monitors the junction temperature,  $T_J$ , of the die and suspends charging if  $T_J$  exceeds  $T_{(\text{SHTDWN})}$ . Charging resumes when  $T_J$  falls below  $T_{(\text{SHTDWN})}$  by approximately 30 °C.

## $\overline{\text{TE}}$ Input (Timer Enabled)

The  $\overline{\text{TE}}$  digital input is used to disable or enable the fast-charge timer. A low-level signal on this pin enables the fast-charge timer and a high-level signal disables this feature.

Note that this applies to both AC and USB charging.

## Timer Fault Recovery

As shown in Figure 3, EUP8020X provides a recovery method to deal with timer fault conditions. The following summarizes this method:

**Condition #1:** Charge voltage above recharge threshold ( $V_{(\text{RCH})}$ ) and timeout fault occurs

Recovery method: EUP8020X waits for the battery voltage to fall below the recharge threshold. This could happen as a result of a load on the battery, self-discharge or battery removal. Once the battery falls below the recharge threshold, the EUP8020X clears the fault and starts a new charge cycle. A POR or  $\overline{\text{CE}}$  or  $\overline{\text{TTE}}$  toggle also clears the fault.

**Condition #2:** Charge voltage below recharge threshold ( $V_{(\text{RCH})}$ ) and timeout fault occurs

Recovery method: Under this scenario, the EUP8020X applies the  $I_{(\text{FAULT})}$  current. This small current is used to detect a battery removal condition and remains on as long as the battery voltage stays below the recharge threshold. If the battery voltage goes above the recharge threshold, then the EUP8020X disables the  $I_{(\text{FAULT})}$  current and executes the recovery method described for condition #1. Once the battery falls below the recharge threshold, the EUP8020X clears the fault and starts a new charge cycle.

A POR or  $\overline{\text{CE}}$  or  $\overline{\text{TTE}}$  toggle also clears the fault.

Packaging Information

TDFN-10

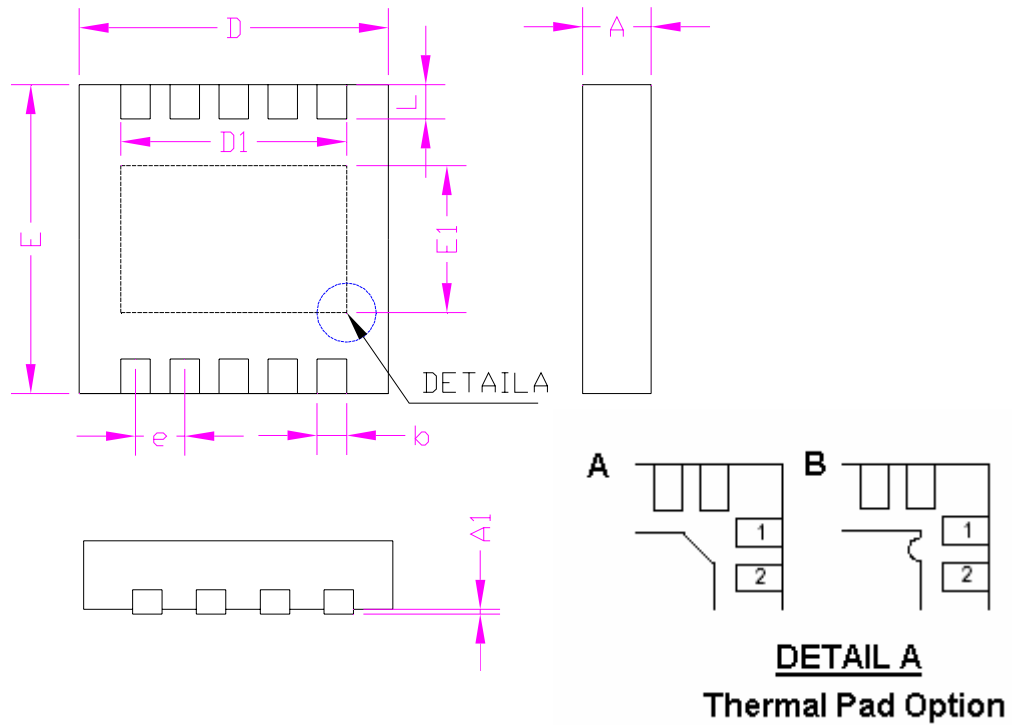

SYMBOLS	MILLIMETERS		INCHES	
	MIN.	MAX.	MIN.	MAX.
A	0.70	0.80	0.028	0.031
A1	0.00	0.05	0.000	0.002
D	2.90	3.10	0.114	0.122
E1	1.70		0.067	
E	2.90	3.10	0.114	0.122
L	0.30	0.50	0.012	0.020
b	0.18	0.30	0.007	0.012
e	0.50		0.020	
D1	2.40		0.094	