



EUTECH
MICROELECTRONICS

EUP9232

LI-ION/POLYMER TWO CELL PROTECTOR

DESCRIPTION

The EUP9232 Series are lithium-ion rechargeable battery protection ICs incorporating high-accuracy voltage detection circuits and delay circuits. The EUP9232 Series are suitable for a 2-cell serial lithium-ion battery pack.

FEATURES

- Highly accurate voltage detector.....Overcharge detection (T_{opt}=+25°C) ±25mV
 - Overcharge hysteresis ±50mV
 - Overdischarge detection ±80mV
 - Overcurrent 1 detection ±20mV
- Variety of detector.....Overcharge detection 4.25V-4.35V step of 5mV
 - Overcharge hysteresis 0.0V-0.4V^{*1} step of 50mV
 - Overdischarge detection 2.0V-2.4V step of 10mV
 - Overdischarge hysteresis 0.0V-1V^{*2} step of 100mV
 - Overcurrent 1 detection 0.095V-0.3V step of 10mV
 - Overcurrent 2 detection 0.9V(fixed)

*1 Overcharge release voltage=Over detection voltage-Overcharge hysteresis voltage

*2 Overdischarge release voltage = Overdischarge detection voltage-Overdischarge hysteresis voltage.

- High input-voltage device: Absolute maximum ratings 28V
- Wide operating voltage range :2 to 16V
- The delay time for every detection can be set via an external capacitor.
(Each delay time for Overcharge detection, Overdischarge detection, Overcurrent detection are "Proportion of hundred to ten to one".)
- Two overcurrent detection levels (Protection for short-circuiting)
- Internal auxiliary over voltage detection circuit (Fall-safe for overcharge detection voltage)
- Internal charge circuit for 0V battery (Unavailable is option)
- Low current consumption
 - Operation mode: 5µA typ. 12µA max. (-40 to +85°C)
 - Power-down mode 0.1µA max. (-40 to +85°C)
- Package: TSSOP-8
- RoHS compliant and 100% lead (Pb)-free

APPLICATIONS

- Lithium-ion rechargeable battery packs.



Block Diagram

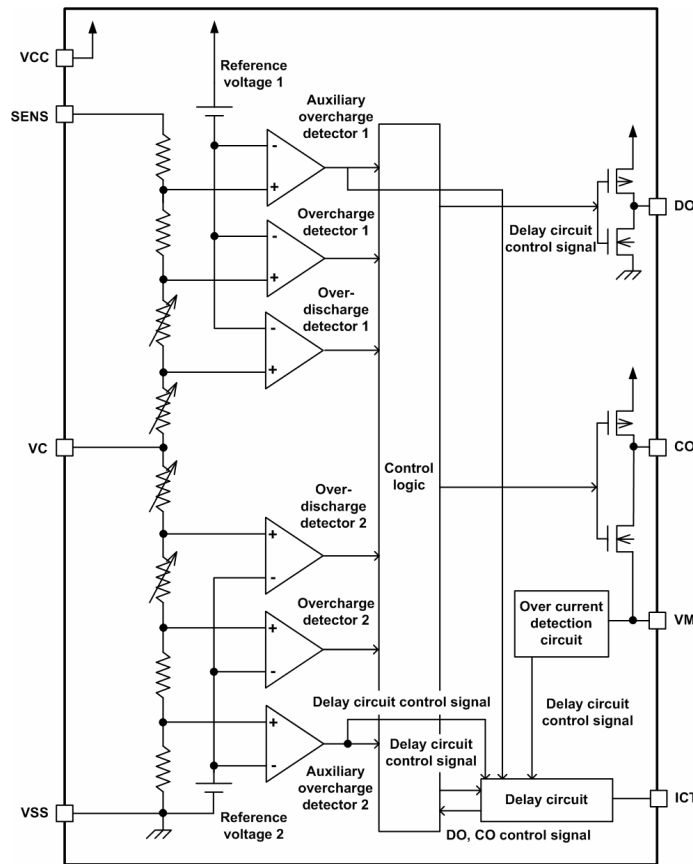

Figure1.

Pin Configurations

Package Type	Pin Configurations
TSSOP-8	<p>(Top View)</p>

Pin Description

Pin No.	Symbol	Pin Description
1	SENS	Detection pin for voltage between SENS and VC (Detection for overcharge and overdischarge)
2	DO	FET gate connection pin for discharge control (CMOS output)
3	CO	FET gate connection pin for charge control (CMOS output)
4	VM	Detection pin for voltage between VM and VSS (Overcurrent detection pin)
5	VSS	Negative power input pin
6	ICT	Capacitor connection pin for detection delay
7	VC	Middle voltage input pin
8	VCC	Positive power input pin



Absolute Maximum Ratings

- Input voltage between V_{CC} and V_{SS} ----- $V_{SS} - 0.3\text{ V}$ to $V_{SS} + 18\text{ V}$
- Input pin voltage for VM ----- $V_{CC} - 28\text{ V}$ to $V_{CC} + 0.3\text{ V}$
- Input pin voltage for SENS and ICT ----- $V_{SS} - 0.3\text{ V}$ to $V_{CC} + 0.3\text{ V}$
- Output pin voltage for CO ----- $V_{VM} - 0.3\text{ V}$ to $V_{CC} + 0.3\text{ V}$
- Output pin voltage for DO ----- $V_{SS} - 0.3\text{ V}$ to $V_{CC} + 0.3\text{ V}$
- Power dissipation TSSOP-8 ----- 300mW
- Operating temperature range ----- -40°C to $+85^{\circ}\text{C}$
- Storage temperature range ----- -40°C to $+125^{\circ}\text{C}$

Ordering Information

Order Number	Package Type	Marking	Operating Temperature range
EUP9232AAQIR1	TSSOP-8	XXXX P9232A	-40°C to 85°C
EUP9232ABQIR1	TSSOP-8	XXXX P9232B	-40°C to 85°C
EUP9232ACQIR1	TSSOP-8	XXXX P9232C	-40°C to 85°C
EUP9232ADQIR1	TSSOP-8	XXXX P9232D	-40°C to 85°C
EUP9232AEQIR1	TSSOP-8	XXXX P9232E	-40°C to 85°C
EUP9232AFQIR1	TSSOP-8	XXXX P9232F	-40°C to 85°C
EUP9232AGQIR1	TSSOP-8	XXXX P9232G	-40°C to 85°C
EUP9232AHQIR1	TSSOP-8	XXXX P9232H	-40°C to 85°C

EUP9232

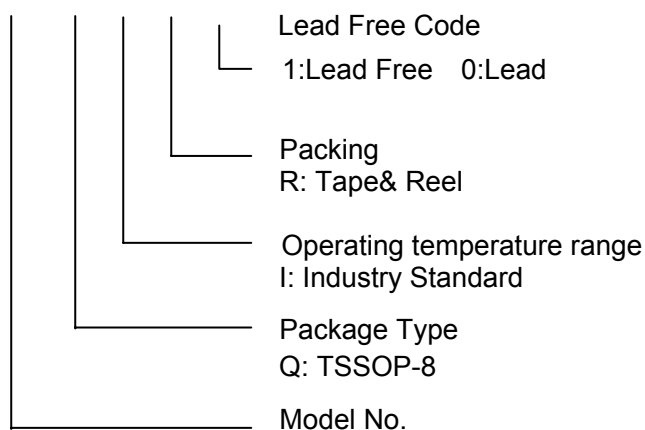

Application Circuit

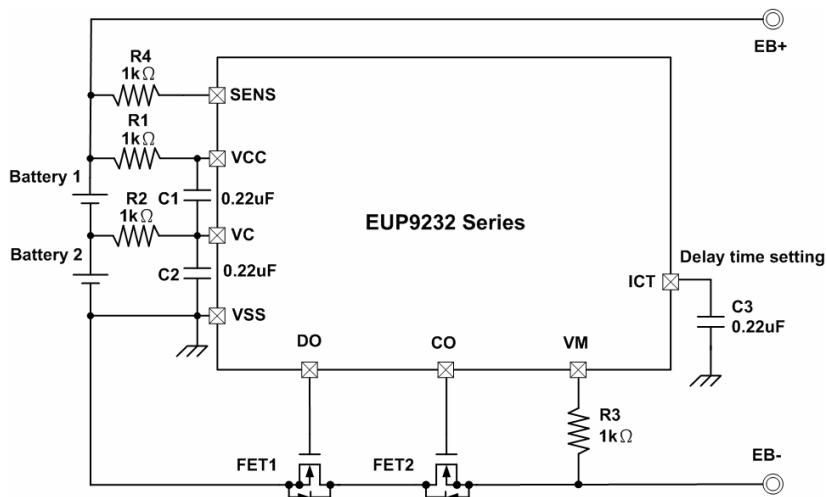

Figure2.

Symbol	Parts	Purpose	Recommend	min.	max.	Remarks
FET1	Nch MOSFET	Discharge control	—	—	—	—
FET2	Nch MOS FET	Charge control	—	—	—	—
R1	Chip resistor	ESD protection	1kΩ	300 Ω	1 kΩ	—
C1	Chip capacitor	Filter	0.22 μF	0 μF	1 μF	—
R2	Chip resistor	ESD protection	1kΩ	300 Ω	1 kΩ	—
C2	Chip capacitor	Filter	0.22 μF	0 μF	1 μF	—
R4	Chip resistor	ESD protection	1 kΩ	= R1 min.	= R1 max.	Same value as R1 and R2. ^{*1}
C3	Chip capacitor	Delay time setting	0.22 μF	0 μF	1 μF	Attention should be paid to leak current of C3. ^{*2}
R3	Chip resistor	Protection for charger reverse connection	1 kΩ	300 Ω	5 kΩ	Discharge can't be stopped at less than 300 Ω when a charger is reverse-connected. ^{*3}

^{*1} R4=R1 is required. Overcharge detection voltage increases by R4. For example 10 kΩ (R4) increases overcharge detection voltage by 20 mV.

^{*2} The overcharge detection delay time (t_{CU}), the overdischarge detection delay time (t_{DD}), and the over current detection delay time (t_{IOV}) change with the external capacitor C3. Refer to the "Electrical Characteristics".

^{*3} When the resistor R3 is set less than 300 Ω and a charger is reverse-connected, current which exceeds the power dissipation of the package will flow and the IC may break.

Caution 1. The above constants may be changed without notice.

2. It has not been confirmed whether the operation is normal or not in circuits other than the above example of connection. In addition, the example of connection shown above and the constant do not guarantee proper operation. Perform through evaluation using the actual application to set the constant.

Product name list

Model / No.	Overcharge detection voltage 1,2 [V _{CU1} , V _{CU2}]	Overcharge release voltage 1,2 [V _{CD1} , V _{CD2}]	Overdischarge detection voltage 1,2 [V _{DD1} , V _{DD2}]	Overdischarge release voltage 1,2 [V _{DU1} , V _{DU2}]	Overcurrent detection voltage 1 [V _{IOV1}]	Overcharge Detection delay time [t _{cu}] C3 = 0.22uF	0V battery charge function
EUP9232AA	4.28 V	4.05 V	2.3 V	2.9 V	0.095 V	1.0 s	Available
EUP9232AB	4.25 V	4.05 V	2.4 V	3.0 V	0.15 V	1.0 s	Available
EUP9232AC	4.30 V	4.05 V	2.0 V	3.0 V	0.30 V	1.0 s	Available
EUP9232AD	4.30 V	4.05 V	2.4 V	3.0 V	0.21 V	1.0 s	Unavailable
EUP9232AE	4.325 V	4.05 V	2.3 V	2.9 V	0.21 V	1.0 s	Unavailable
EUP9232AF	4.325 V	4.15 V	2.3 V	2.9 V	0.30 V	1.0 s	Unavailable
EUP9232AG	4.35 V	4.15 V	2.3 V	3.0 V	0.21 V	1.0 s	Available
EUP9232AH	4.35 V	4.15 V	2.3 V	3.0 V	0.30 V	1.0 s	Available

Note: It is possible to change the detection voltages of the product other than above. For details, please contact our sales office.

Detection Voltage	Symbol	Selection range					Unit
Overcharge detection voltage 1,2	V _{CU1,2}	4.25	4.28	4.3	4.325	4.35	V
Overcharge release voltage 1,2	V _{CD1,2}	3.9	4	4.05	4.15		
Overdischarge detection voltage 1,2	V _{DD1,2}	2	2.2	2.3	2.4		
Overdischarge release voltage 1,2	V _{DU1,2}	2.5	2.8	2.9	3		
Overcurrent detection voltage 1	V _{IOV1}	0.095	0.15	0.21	0.3		

Function	Selection	
0V battery charge function	Available	Unavailable

Electrical Characteristics (1) Except detection delay time (25°C)

(Ta=25°C unless otherwise specified)

Symbol	Parameter	Condition	Min	Typ	Max	Unit	Test Condition	Test Circuit
Detection Voltage								
V _{CU1,2}	Overcharge detection voltage 1,2	3.90 to 4.60V Adjustable	V _{CU1,2} -0.025	V _{CU1,2}	V _{CU1,2} +0.025	V	1,2	1
V _{CUaux1,2}	Auxiliary overcharge detection voltage 1,2	V _{CU1,2} × 1.25	V _{CU1,2} × 1.21	V _{CU1,2} × 1.25	V _{CU1,2} × 1.29	V	1,2	1
V _{CD1,2}	Overcharge release voltage 1,2	3.60 to 4.60V Adjustable	V _{CD1,2} -0.050	V _{CD1,2}	V _{CD1,2} +0.050	V	1,2	1
V _{DD1,2}	Overdischarge detection voltage 1,2	1.70 to 2.60V Adjustable	V _{DD1,2} -0.080	V _{DD1,2}	V _{DD1,2} +0.080	V	1,2	1
V _{DU1,2}	Overdischarge release voltage 1,2	1.70 to 3.80V Adjustable	V _{DU1,2} -0.100	V _{DU1,2}	V _{DU1,2} +0.100	V	1,2	1
V _{IOV1}	Overcurrent detection voltage1	0.07 to 0.03V Adjustable	V _{IOV1} -0.020	V _{IOV1}	V _{IOV1} +0.020	V	3	1
V _{IOV2}	Overcurrent detection voltage 2	Load short circuit	0.5	0.9	1.3	V	3	1
T _{COE1}	Temperature coefficient 1 for detection voltage ^{*1}	Ta= -40 to +85°C	-0.6	0	0.6	mV/°C	---	---
T _{COE2}	Temperature coefficient 2 for detection voltage ^{*2}	Ta= -40 to +85°C	-0.24	-0.05	0	mV/°C	---	---
Delay Time (C3=0.22μF)								
t _{CU1,2}	Overcharge detection delay time 1,2	1.0s	0.7	1.00	1.4	s	8,9	5
t _{DD1,2}	Overdischarge detection delay time1,2	0.1s	68	100	138	ms	8,9	5
t _{IOV1}	Overcurrent detection delay time 1	0.01s	6.7	10	13.9	ms	10	5
t _{IOV2}	Overcurrent detection delay time 2	-	-	220	-	us	14	1
Input Voltage, Operation Voltage								
V _{DSOP1}	Operation voltage between VCC and VSS	Internal circuit operating voltage	2.0	---	16	V	---	---
V _{DSOP2}	Operation voltage between VCC and VM ^{*3}	Internal circuit operating voltage	2.0	---	28	V	---	---
Current Consumption								
I _{OPE}	Current consumption during normal operation	V1=V2=3.6V	-	5	10	μA	4	2
I _{PDN}	Current consumption at power down	V1=V2=1.5V	-	-	0.1	μA	4	2
Output Voltage								
V _{DO(H)}	DO voltage "H"	I _{OUT} =10μA	V _{CC} -0.05	V _{CC} -0.003	V _{CC}	V	6	3
V _{DO(L)}	DO voltage "L"	I _{OUT} =10μA	V _{SS}	V _{SS} +0.003	V _{SS} +0.05	V	6	3
V _{CO(H)}	CO voltage "H"	I _{OUT} =10μA	V _{CC} -0.15	V _{CC} -0.019	V _{CC}	V	7	4
V _{CO(L)}	CO voltage "L"	I _{OUT} =10μA	V _{SS}	V _{SS} +0.003	V _{SS} +0.05	V	7	4
Internal Resistance								
R _{VCM}	Resistance between VCC and VM	V1=V2=1.5V V _{VM} =0V	100	300	900	kΩ	5	2
R _{VSM}	Resistance between VSS and VM	V1=V2=3.5V V _{VM} =1.0V	50	100	170	kΩ	5	2

Electrical Characteristics (1) Except detection delay time (25°C)

(Ta=25°C unless otherwise specified)

Symbol	Parameter	Condition	Min	Typ	Max	Unit	Test Condition	Test Circuit
0V Battery Charging Function								
V_{0CHA}	0V battery charge starting charger voltage	0V battery charging function "available"	0.38	0.75	1.12	V	11	6
$V_{0INH1,2}$	0V battery charge inhibition battery voltage 1,2	0V battery charging function "unavailable"	0.32	0.88	1.44	V	12,13	6

*1. Temperature coefficient 1 for detection voltage should be applied to overcharge detection voltage, overcharge release voltage, overdischarge detection voltage, and overdischarge release voltage.

*2. Temperature coefficient 2 for detection voltage should be applied to overcurrent detection voltage.

*3. The DO and CO pin logic are established at the operating voltage.

Electrical Characteristics (2) Except detection delay time (-20°C to +70°C)

(Ta= -20°C to +70°C unless otherwise specified)

Symbol	Parameter	Condition	Min	Typ	Max	Unit	Test Condition	Test Circuit
Detection Voltage								
$V_{CU1,2}$	Overcharge detection voltage 1,2	3.90 to 4.60V Adjustable	$V_{CU1,2}$ -0.045	$V_{CU1,2}$	$V_{CU1,2}$ +0.040	V	1,2	1
$V_{CUaux1,2}$	Auxiliary overcharge detection voltage 1,2	$V_{CU1,2} \times 1.25$	$V_{CU1,2}$ $\times 1.19$	$V_{CU1,2}$ $\times 1.25$	$V_{CU1,2}$ $\times 1.31$	V	1,2	1
$V_{CD1,2}$	Overcharge release voltage 1,2	3.60 to 4.60V Adjustable	$V_{CD1,2}$ -0.070	$V_{CD1,2}$	$V_{CD1,2}$ +0.065	V	1,2	1
$V_{DD1,2}$	Overdischarge detection voltage 1,2	1.70 to 2.60V Adjustable	$V_{DD1,2}$ -0.100	$V_{DD1,2}$	$V_{DD1,2}$ +0.095	V	1,2	1
$V_{DU1,2}$	Overdischarge release voltage 1,2	1.70 to 3.80V Adjustable	$V_{DU1,2}$ -0.120	$V_{DU1,2}$	$V_{DU1,2}$ +0.115	V	1,2	1
V_{IOV1}	Overcurrent detection voltage1	0.07 to 0.03V Adjustable	V_{IOV1} -0.029	V_{IOV1}	V_{IOV1} +0.029	V	3	1
V_{IOV2}	Overcurrent detection voltage 2	Load short circuit	0.45	0.9	1.35	V	3	1
T_{COE1}	Temperature coefficient 1 for detection voltage ^{*1}	Ta= -40 to +85°C	-0.6	0	0.6	mV/°C	---	---
T_{COE2}	Temperature coefficient 2 for detection voltage ^{*2}	Ta= -40 to +85°C	-0.24	-0.05	0	mV/°C	---	---
Delay Time (C3=0.22µF)								
$t_{CU1,2}$	Overcharge detection delay time 1,2	1.0s	0.6	1.00	1.84	s	8,9	5
$t_{DD1,2}$	Overdischarge detection delay time1,2	0.1s	67	100	140	ms	8,9	5
t_{IOV1}	Overcurrent detection delay time 1	0.01s	6.5	10	14.5	ms	10	5
t_{IOV2}	Overcurrent detection delay time 2	-	-	220	-	us	14	1
Input Voltage, Operation Voltage								
V_{DSOP1}	Operation voltage between VCC and VSS	Internal circuit operating voltage	2.0	---	16	V	---	---
V_{DSOP2}	Operation voltage between VCC and VM ^{*3}	Internal circuit operating voltage	2.0	---	28	V	---	---

Electrical Characteristics (2) Except detection delay time (-20°C to +70°C)

(Ta= -20°C to +70°C unless otherwise specified)

Current Consumption								
I_{OPE}	Current consumption during normal operation	V1=V2=3.6V	-	5	11	μA	4	2
I_{PDN}	Current consumption at power down	V1=V2=1.5V	-	-	0.1	μA	4	2
Output Voltage								
$V_{DO(H)}$	DO voltage "H"	$I_{OUT}=10\mu A$	V_{CC} -0.14	V_{CC} -0.003	V_{CC}	V	6	3
$V_{DO(L)}$	DO voltage "L"	$I_{OUT}=10\mu A$	V_{SS}	V_{SS} +0.003	V_{SS} +0.14	V	6	3
$V_{CO(H)}$	CO voltage "H"	$I_{OUT}=10\mu A$	V_{CC} -0.24	V_{CC} -0.019	V_{CC}	V	7	4
$V_{CO(L)}$	CO voltage "L"	$I_{OUT}=10\mu A$	V_{SS}	V_{SS} +0.003	V_{SS} +0.14	V	7	4
Internal Resistance								
R_{VCM}	Resistance between VCC and VM	V1=V2=1.5V $V_{VM}=0V$	83	300	1200	k Ω	5	2
R_{VSM}	Resistance between VSS and VM	V1=V2=3.5V $V_{VM}=1.0V$	40	100	190	k Ω	5	2
0V Battery Charging Function								
V_{0CHA}	0V battery charge starting charger voltage	0V battery charging function "available"	0.29	0.75	1.21	V	11	6
$V_{0INH1,2}$	0V battery charge inhibition battery voltage 1,2	0V battery charging function "unavailable"	0.23	0.88	1.53	V	12,13	6

*1. Temperature coefficient 1 for detection voltage should be applied to overcharge detection voltage, overcharge release voltage, overdischarge detection voltage, and overdischarge release voltage.

*2. Temperature coefficient 2 for detection voltage should be applied to overcurrent detection voltage.

*3. The DO and CO pin logic are established at the operating voltage.

Electrical Characteristics (3) Except detection delay time (-40°C to +85°C)

(Ta= -40°C to +85°C unless otherwise specified)

Symbol	Parameter	Condition	Min	Typ	Max	Unit	Test Condition	Test Circuit
Detection Voltage								
$V_{CU1,2}$	Overcharge detection voltage 1,2	3.90 to 4.60V Adjustable	$V_{CU1,2}$ -0.055	$V_{CU1,2}$	$V_{CU1,2}$ +0.045	V	1,2	1
$V_{CUaux1,2}$	Auxiliary overcharge detection voltage 1,2	$V_{CU1,2} \times 1.25$	$V_{CU1,2}$ $\times 1.19$	$V_{CU1,2}$ $\times 1.25$	$V_{CU1,2}$ $\times 1.31$	V	1,2	1
$V_{CD1,2}$	Overcharge release voltage 1,2	3.60 to 4.60V Adjustable	$V_{CD1,2}$ -0.080	$V_{CD1,2}$	$V_{CD1,2}$ +0.070	V	1,2	1
$V_{DD1,2}$	Overdischarge detection voltage 1,2	1.70 to 2.60V Adjustable	$V_{DD1,2}$ -0.110	$V_{DD1,2}$	$V_{DD1,2}$ +0.100	V	1,2	1
$V_{DU1,2}$	Overdischarge release voltage 1,2	1.70 to 3.80V Adjustable	$V_{DU1,2}$ -0.130	$V_{DU1,2}$	$V_{DU1,2}$ +0.120	V	1,2	1
V_{IOV1}	Overcurrent detection voltage 1	0.07 to 0.03V Adjustable	V_{IOV1} -0.033	V_{IOV1}	V_{IOV1} +0.033	V	3	1
V_{IOV2}	Overcurrent detection voltage 2	Load short circuit	0.4	0.9	1.4	V	3	1
T_{COE1}	Temperature coefficient 1 for detection voltage ^{*1}	Ta= -40 to +85°C	-0.6	0	0.6	mV/°C	---	---
T_{COE2}	Temperature coefficient 2 for detection voltage ^{*2}	Ta= -40 to +85°C	-0.24	-0.05	0	mV/°C	---	---

Electrical Characteristics (3) Except detection delay time (-40°C to +85°C)

(Ta= -40°C to +85°C unless otherwise specified)

Delay Time (C3=0.22μF)								
$t_{CU1,2}$	Overcharge detection delay time 1,2	1.0s	0.55	1.00	2.06	s	8,9	5
$t_{DD1,2}$	Overdischarge detection delay time1,2	0.1s	67	100	141	ms	8,9	5
t_{IOV1}	Overcurrent detection delay time 1	0.01s	6.3	10	14.7	ms	10	5
t_{IOV2}	Overcurrent detection delay time 2	-	-	220	-	us	14	1
Input Voltage, Operation Voltage								
V_{DSOP1}	Operation voltage between VCC and VSS	Internal circuit operating voltage	2.0	---	16	V	---	---
V_{DSOP2}	Operation voltage between VCC and VM ^{*3}	Internal circuit operating voltage	2.0	---	28	V	---	---
Current Consumption								
I_{OPE}	Current consumption during normal operation	V1=V2=3.6V	-	5	12	μA	4	2
I_{PDN}	Current consumption at power down	V1=V2=1.5V	-	-	0.1	μA	4	2
Output Voltage								
$V_{DO(H)}$	DO voltage "H"	$I_{OUT}=10\mu A$	V_{CC} -0.17	V_{CC} -0.003	V_{CC}	V	6	3
$V_{DO(L)}$	DO voltage "L"	$I_{OUT}=10\mu A$	V_{SS}	V_{SS} +0.003	V_{SS} +0.17	V	6	3
$V_{CO(H)}$	CO voltage "H"	$I_{OUT}=10\mu A$	V_{CC} -0.27	V_{CC} -0.019	V_{CC}	V	7	4
$V_{CO(L)}$	CO voltage "L"	$I_{OUT}=10\mu A$	V_{SS}	V_{SS} +0.003	V_{SS} +0.17	V	7	4
Internal Resistance								
R_{VCM}	Resistance between VCC and VM	V1=V2=1.5V $V_{VM}=0V$	78	300	1310	kΩ	5	2
R_{VSM}	Resistance between VSS and VM	V1=V2=3.5V $V_{VM}=1.0V$	30	100	200	kΩ	5	2
0V Battery Charging Function								
V_{0CHA}	0V battery charge starting charger voltage	0V battery charging function "available"	0.26	0.75	1.25	V	11	6
$V_{0INH1,2}$	0V battery charge inhibition battery voltage 1,2	0V battery charging function "unavailable"	0.2	0.88	1.57	V	12,13	6

*1. Temperature coefficient 1 for detection voltage should be applied to overcharge detection voltage, overcharge release voltage, overdischarge detection voltage, and overdischarge release voltage.

*2. Temperature coefficient 2 for detection voltage should be applied to overcurrent detection voltage.

*3. The DO and CO pin logic are established at the operating voltage.

TEST Circuits

(1) Test Condition 1, Test Circuit 1

Set S1=OFF, V1= V2 =3.6 V, and V3= 0 V under normal condition. Increase V1 from 3.6V gradually. The V1 voltage when CO = "L" is overcharge detection voltage 1 (V_{CU1}). Decrease V1 gradually. The V1 voltage when CO = "H" is overcharge release voltage 1 (V_{CD1}). Further decrease V1. The V1 voltage when DO= "L" is overdischarge voltage 1 (V_{DD1}). Increase V1 gradually. The V1 voltage when DO = "H" is overdischarge release voltage 1 (V_{DU1}). Set S1 = ON, and V1= V2= 3.6 V and V3 = 0 V under normal condition. Increase V1 from 3.6V gradually. The V1 voltage when CO = "L" is auxiliary overcharge detection voltage 1 (V_{CUaux1}).

(2) Test Condition 2, Test Circuit 1

Set S1=OFF, V1= V2 =3.6 V, and V3= 0V under normal condition. Increase V2 from 3.6V gradually. The V2 voltage when CO = "L" is overcharge detection voltage 2 (V_{CU2}). Decrease V2 gradually. The V2 voltage when CO = "H" is overcharge release voltage 2 (V_{CD2}). Further decrease V2. The V2 voltage when DO= "L" is overdischarge voltage 2 (V_{DD2}). Increase V2 gradually. The V2 voltage when DO = "H" is overdischarge release voltage 2 (V_{DU2}). Set S1 = ON, and V1= V2= 3.6 V and V3 = 0 V under normal condition. Increase V2 from 3.6V gradually. The V2 voltage when CO = "L" is auxiliary overcharge detection voltage 2 (V_{CUaux2}).

(3) Test Condition 3, Test Circuit 1

Set S1=OFF, V1 =V2 =3.6 V, and V3 = 0V under normal condition. Increase V3 from 0V gradually. The V3 voltage when DO= "L" is overcurrent detection voltage 1 (V_{IOV1}). Set S1 =ON, V1=V2= 3.6V, V3=0 under normal condition. Increase V3 from 0 V gradually. V3 voltage when DO= "L" is overcurrent detection voltage 2 (V_{IOV2}).

(4) Test Condition 4, Test Circuit 2

Set S1 = ON, V1 = V2 =3.6V, and V3 =0 V under normal condition and measure current consumption. Current consumption I1 is the normal condition current consumption (I_{OPE}). Set S1 =OFF, V1 =V2 =1.5V under overdischarge condition and measure current consumption. Current consumption I1 is the power-down current consumption (I_{PDN}).

(5) Test Condition 5, Test Circuit 2

Set S1 =ON, V1=V2 = 1.5 V, and V3 =0 V under overdischarge condition. $(V1+V2)/I2$ is the internal resistance between VCC and VM (R_{vcm}). Set S1= ON, V1=V2=3.5V, and V3 = 1.0 V under overcurrent condition. V3 / I2 is the internal resistance between VSS and VM (R_{vsm}).

(6) Test Condition 6, Test Circuit 3

Set S1=ON, S2=OFF, V1=V2=3.6V, and V3 =0 V under normal condition. Increase V4 from 0V gradually. The V4 voltage when I1=10 μ A is DO voltage "H" (V_{DOH}).

Set S1=OFF, S2=ON, V1=V2=3.6V, and V3=0.5 V under overcurrent condition. Increase V5 from 0V gradually. The V5 voltage when I2=10 μ A is DO voltage "L" (V_{DOL}).

(7) Test Condition 7, Test Circuit 4

Set S1 = ON, S2=OFF, V1=V2 =3.6V, and V3 =0 V under normal condition. Increase V4 from 0V gradually. The V4 voltage when I1=10 μ A is the CO "H" voltage (V_{COH}).

Set S1=OFF, S2=ON, V1=4.4, V2 =3.6V, and V3 =0 V under overcharge condition. Increase V4 from 0V gradually. The V5 voltage when I1=10 μ A is CO voltage "L" (V_{COL}).

(8) Test Condition 8, Test Circuit 5

Set V1=V2=3.6V and V3=0V under normal condition. Increase V1 from ($V_{CU1}-0.2V$) to ($V_{CU1}+0.2V$) immediately (within 10 μ s). The time after V1 becomes ($V_{CU1}+0.2V$) until CO goes "L" is the overcharge detection delay time 1 (t_{CU1}).

Set V1=V2=3.5V and V3=0V under normal condition. Decrease V1 from ($V_{DD1}+0.2V$) to ($V_{DD1}-0.2V$) immediately (within 10 μ s). The time after V1 becomes ($V_{DD1}-0.2V$) until DO goes "L" is the overcharge detection delay time 1 (t_{DD1}).

(9) Test Condition 9, Test Circuit 5

Set V1=V2=3.6V and V3=0V under normal condition. Increase V2 from ($V_{CU2}-0.2V$) to ($V_{CU2}+0.2V$) immediately (within 10 μ s). The time after V2 becomes ($V_{CU2}+0.2V$) until CO goes "L" is the overcharge detection delay time 2 (t_{CU2}).

Set V1=V2=3.6V and V3=0V under normal condition. Decrease V2 from ($V_{DD2}+0.2V$) to ($V_{DD2}-0.2V$) immediately (within 10 μ s). The time after V2 becomes ($V_{DD2}-0.2V$) until DO goes "L" is the overcharge detection delay time 2 (t_{DD2}).

(10) Test Condition 10, Test Circuit 5

Set V1=V2=3.6V and V3=0V under normal condition. Increase V3 from 0V to 0.5V immediately (within 10 μ s). The time after V3 becomes 0.5V until DO goes "L" is the overcurrent detection delay time 1 (t_{IOV1}).

(11) Test Condition 11, Test Circuit 6

Set V1=V2=0V and V3=2V, and decrease V3 gradually. The V3 voltage when CO="L" ($V_{CC}-0.3V$ or lower) is the 0V charge starting voltage (V_{OCHA}).

(12) Test Condition 12, Test Circuit 6

Set $V1=0V$ and $V2=3.6V$ and $V3=12V$, and Increase $V1$ gradually. The $V1$ voltage when $CO="H"$ ($V_{VM}+0.3V$ or higher) is the 0V charge inhibiting voltage 1 (V_{0INH1}).

(13) Test Condition 13, Test Circuit 6

Set $V1=3.6V$ and $V2=0V$ and $V3=12V$, and Increase $V2$ gradually. The $V2$ voltage when $CO="H"$ ($V_{VM}+0.3V$ or higher) is the 0V charge inhibiting voltage 2 (V_{0INH2}).

(14) Test Condition 14, Test Circuit 1

Set $S1=ON$, $V1=V2=3.6V$ and $V3=0V$ under normal condition. Increase $V3$ from $0V$ to $1.5V$ immediately (within $10\ \mu s$). The time after DO goes "L" is the overcurrent detection delay time 2 (t_{IOV2}).



Test Circuit

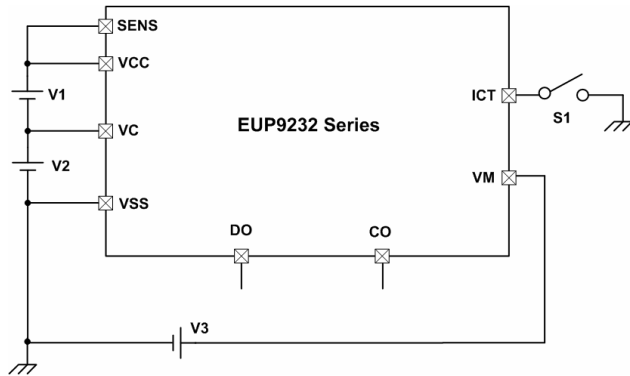

Test Circuit 1

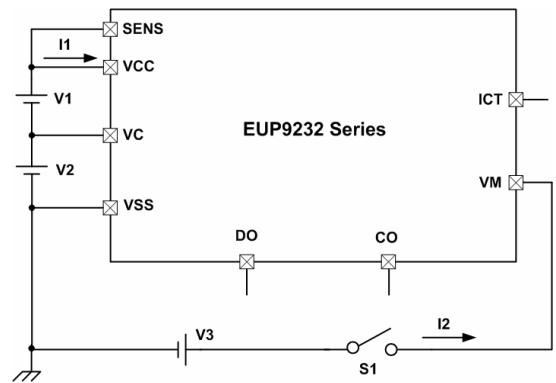

Test t Circuit 2

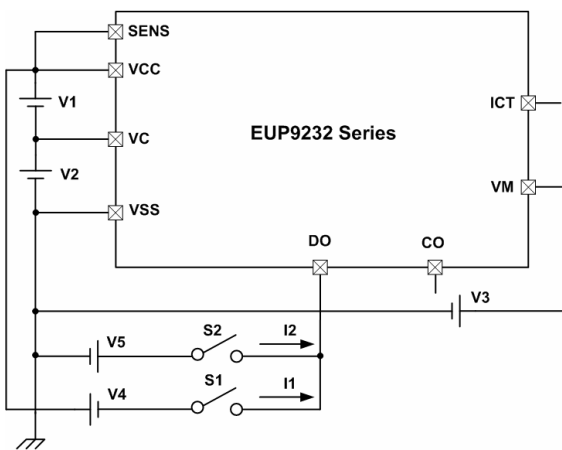

Test Circuit 3

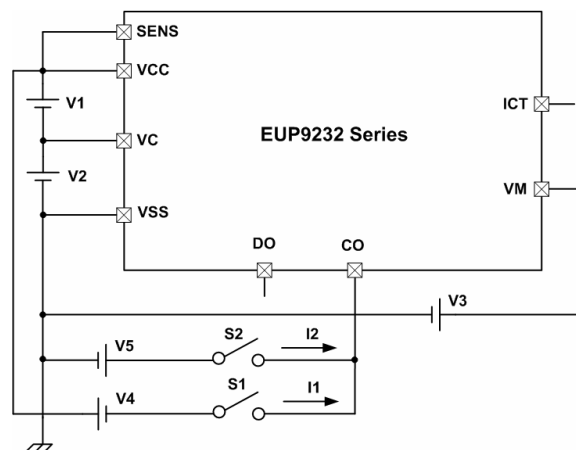

Test Circuit 4

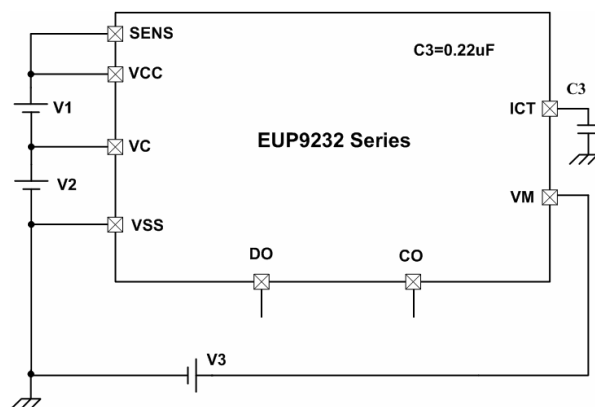

Test Circuit 5

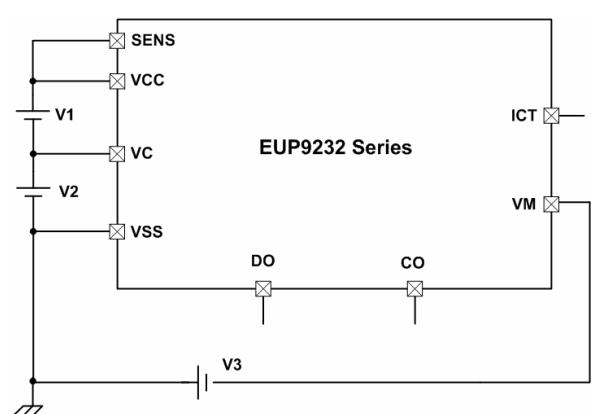

Test Circuit 6



Typical Characteristics

1. Detection Voltage Temperature Characteristics

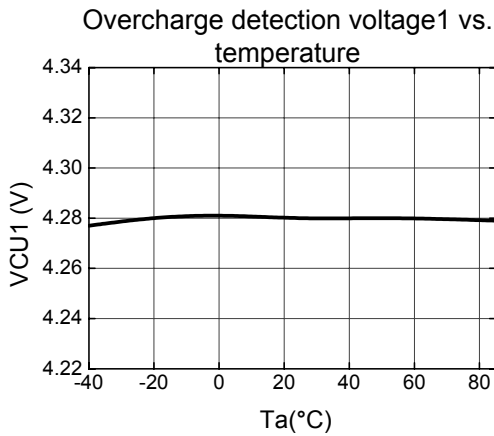

Figure3.

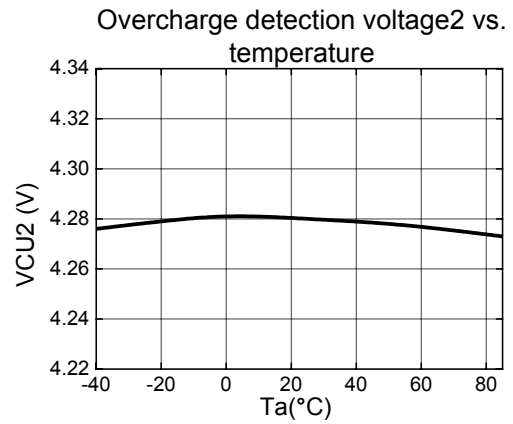

Figure4.

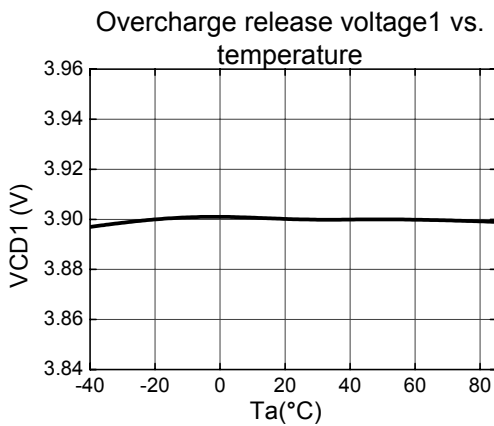

Figure5.

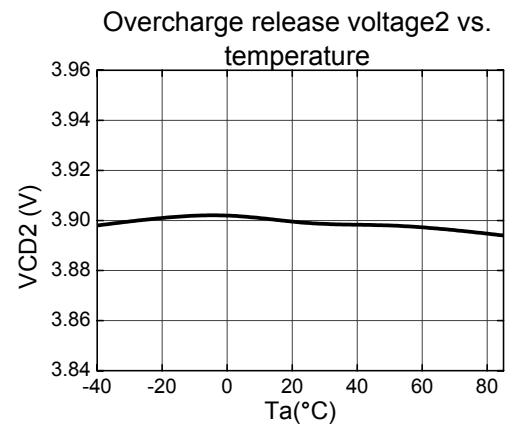

Figure6.

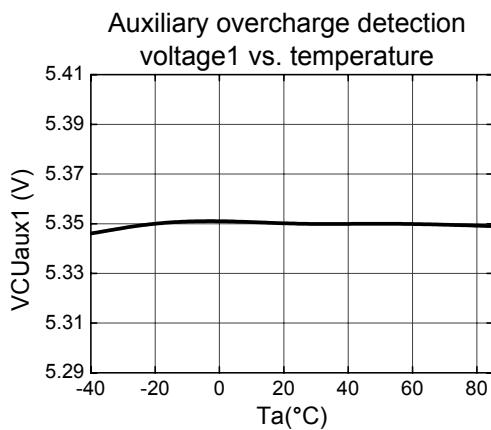

Figure7.

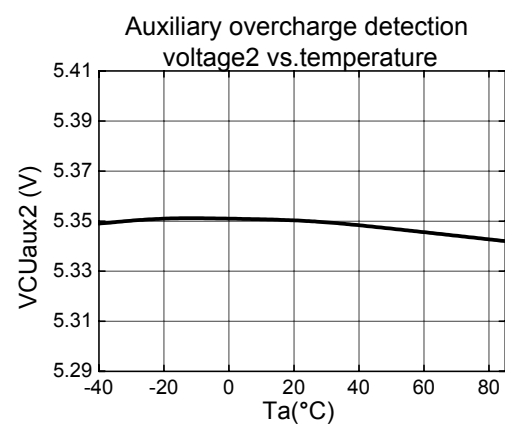

Figure8.



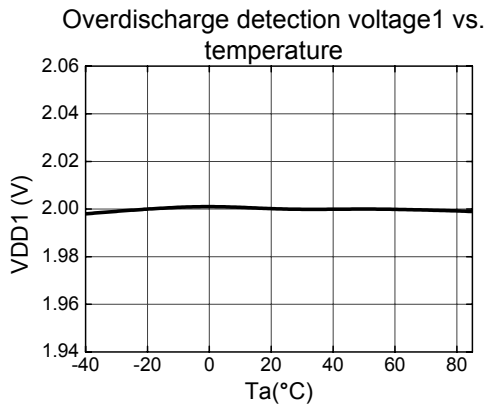

Figure 9.

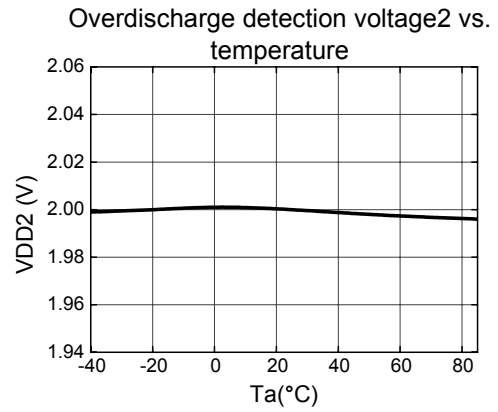

Figure10.

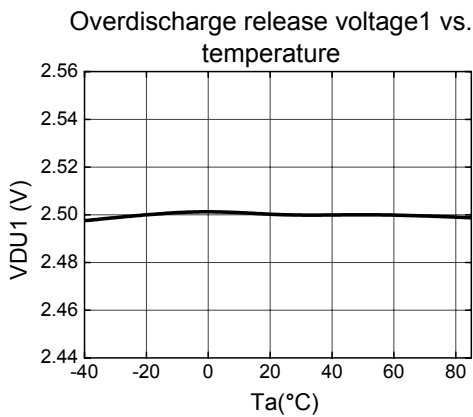

Figure11.

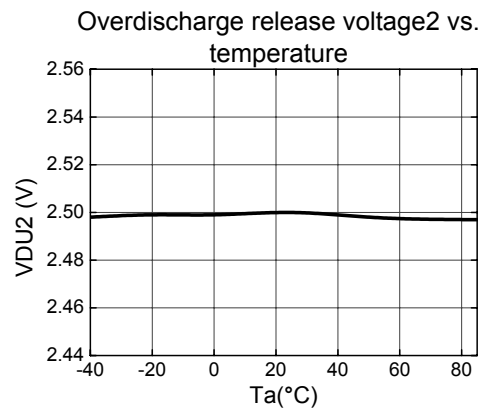

Figure12.

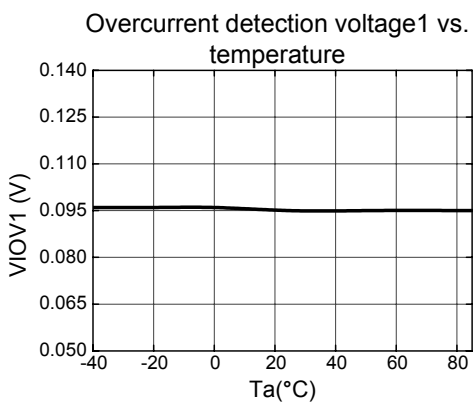

Figure13.

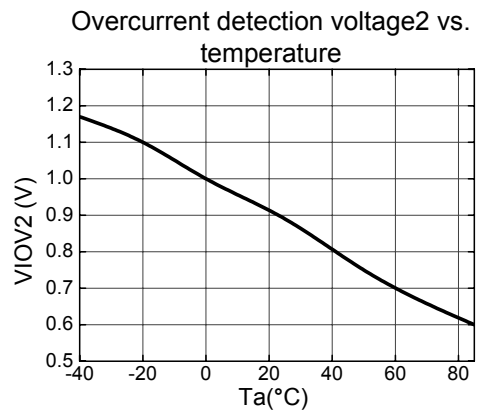

Figure14.



2. Current Consumption Temperature Characteristics

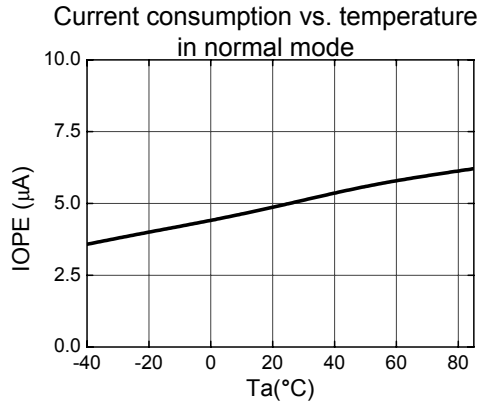

Figure15.

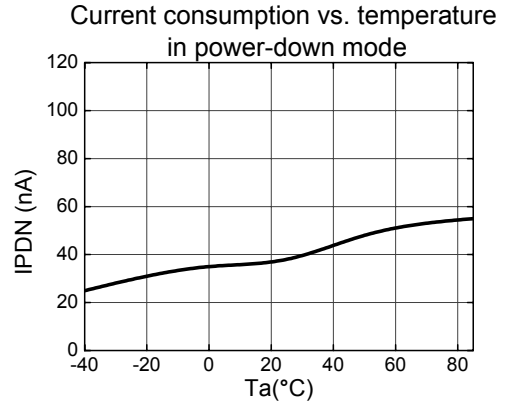

Figure16.

3. Delay Time Temperature Characteristics

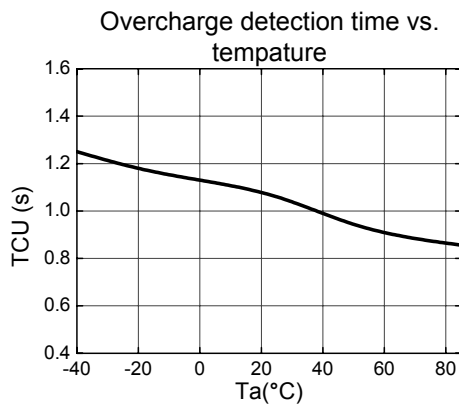

Figure17.

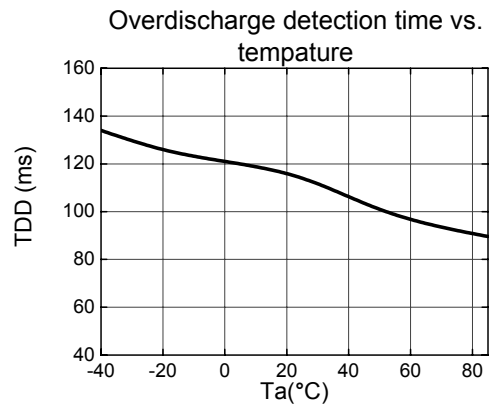

Figure18.

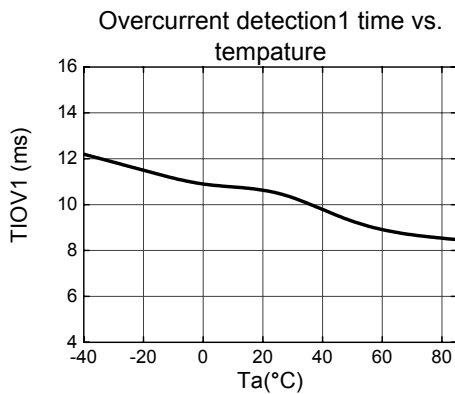

Figure19.



Description of Operation

Normal Condition ^{*1}

This IC monitors the voltages of the two serially connected batteries and the discharge current to control charging and discharging. When the voltages of two batteries are in the range from the overdischarge detection voltage ($V_{DD1,2}$) to the overcharge detection voltage ($V_{CU1,2}$), and the current flowing through the batteries becomes equal or lower than a specified value (the VM pin voltage is equal or lower than overcurrent detection voltage 1), the charging and discharging FETs are turned on. In this condition, charging and discharging can be carried out freely. This condition is called normal condition.

Overcurrent Condition

When the discharging current becomes equal to or higher than a specified value (the VM pin voltage is equal to or higher than the overcurrent detection voltage) during discharging under normal condition and it continues for the overcurrent detection delay time (t_{IOV}) or longer, the discharging FET is turned off to stop discharging. This condition is called overcurrent condition. When the discharging FET is off and a load is connected, the VM pin voltage equals the V_{CC} potential.

The overcurrent condition returns to the normal condition when the load is released and the impedance between the $E\bar{B}$ - and $E\bar{B}$ + pins (refer to the **Figure 2** for a connection example) is 400 k Ω or higher. When the load is released, the VM pin, which is shorted to the VSS pin with the R_{vsm} resistor, goes back to the V_{SS} potential. The IC detects that the VM pin potential returns to overcurrent detection voltage 1 (V_{IOV1}) or lower and returns to the normal condition.

Overcharge Condition

Following two cases are detected as overcharge conditions:

- (1) If one of the battery voltages becomes higher than the overcharge detection voltage ($V_{CU1,2}$) during charging under normal condition and it continues for the overcharge detection delay time ($t_{CU1,2}$) or longer, the charging FET turns off to stop charging.
- (2) If one of the battery voltages becomes higher than the auxiliary overcharge detection voltage ($V_{CUaux1,2}$) the charging FET turns off immediately to stop charging.

The auxiliary overcharge detection voltages ($V_{CUaux1,2}$) are correlated with the overcharge detection voltages ($V_{CU1,2}$) and are defined by following equation:

$$V_{CUaux1,2} [V] = 1.25 \times V_{CU1,2}$$

The overcharge condition is release in two cases:

- (1) The battery voltage which exceeded the overcharge detection voltage ($V_{CU1,2}$) falls below the overcharge release voltage ($V_{CD1,2}$), the charging FET turns on and the normal condition returns.
- (2) If the battery voltage which exceeded the overcharge detection voltage ($V_{CU1,2}$) is equal or higher than the overcharge release voltage ($V_{CD1,2}$), but the charger is removed, a load is placed, and discharging starts, the charging FET turns on and the normal condition returns.

The release mechanism is as follows: the discharge current flows through an internal parasitic diode of the charging FET immediately after a load is installed and discharging starts, and the VM pin voltage increases by about 0.6 V from the VSS pin voltage momentarily. The IC detects this voltage (overcurrent detection voltage 1 or higher), releases the overcharge condition and returns to the normal condition.

Overdischarge Condition

If any one of the battery voltages falls below the overdischarge detection voltage ($V_{DD1,2}$) during discharging under normal condition and it continues for the overdischarge detection delay time ($t_{DD1,2}$) or longer, the discharging FET turns off and discharging stops. This condition is called the overdischarge condition. When the discharging FET turns off, the VM pin voltage becomes equal to the VCC voltage and the IC's current consumption falls below the power-down current consumption (I_{PDN}). This condition is called the power-down condition. The VM and VCC pins are shorted by the R_{vcm} resistor under the overdischarge and power-down conditions.

The power-down condition is canceled when the charger is connected and the voltage between VM and VCC is overcurrent detection voltage 2 or higher. When all the battery voltages becomes equal to or higher than the overdischarge release voltage ($V_{DU1,2}$) in this condition, the overdischarge condition changes to the normal condition.

Delay Circuits

The overcharge detection delay time ($t_{CU1,2}$), the overdischarge detection delay time ($t_{DD1,2}$), and the overcurrent detection delay time (t_{IOV1}) change with an external capacitor (C3). Since one capacitor determine each delay time, delay times are correlated by the following ratio:

Overcharge delay time: Overdischarge delay time :

Overcurrent delay time =100:10:1

The delay times are calculated by the following equations : (Ta=-40 to +85)

	Min.	Typ.	Max.
Overcharge detection delay time t_{CU} [s] = Delay factor	(2.5,	4.545,	$9.364) \times C3$ [μ F]
Overdischarge detection delay time t_{DD} [s] = Delay factor	(0.3045,	0.4545,	$0.6409) \times C3$ [μ F]
Overcurrent detection delay time t_{IOV1} [s] = Delay factor	(0.02864,	0.04545,	$0.06682) \times C3$ [μ F]

Remark The delay time for overcurrent detection 2 is fixed by an internal circuit. The delay time cannot be changed via an external capacitor.

0V Battery Charging Function *2

This function is used to recharge both of two serially-connected batteries after they self-discharge to 0V. When the 0V charging start voltage (V_{0CHA}) or higher is applied to between VM and VCC by connecting the charger, the charging FET gate is fixed to V_{CC} potential.

When the voltage between the gate and the source of the charging FET becomes equal to or higher than the turn-on voltage by the charger voltage, the charging FET turns on to start charging. At this time, the discharging FET turns off and the charging current flows through the internal parasitic diode in the discharging FET. If all the battery voltages become equal to or higher than the overdischarge release voltage ($V_{DU1,2}$), the normal condition returns.

0V Battery Charge Inhibiting Function *2

This function is used for inhibiting charging when either of the connected batteries goes 0V due to its self-discharge. When the voltage of either of the connected batteries goes below 0 V charge inhibit voltage 1 and 2 ($V_{OINH1,2}$), the charging FET gate is fixed to "EB-" to inhibit charging. Charging is possible only when the voltage of both connected batteries goes 0V charge inhibit voltage 1 and 2 ($V_{OINH1,2}$) or more. Note that charging may be possible when the total voltage of both connected batteries is less than the minimum value ($V_{DSOPmin}$) of the operating voltage between VCC and VSS even if the voltage of either of the connected batteries is 0 V charge inhibit voltage 1 and 2 ($V_{OINH1,2}$) or less. Charging is prohibited when the total voltage of both connected batteries reaches the minimum value ($V_{DSOPmin}$) of the operating voltage between VCC and VSS.

*1. When initially connecting batteries, the IC may fail to enter the normal condition (discharging ready state). If so, once set the VM pin to VSS voltage (short pins VM and VSS or connect a charger).

*2. Some lithium ion batteries are not recommended to be recharged after having been completely discharged. Please contact the battery manufacturer when you decide to select a 0V battery charging function.

Timing Charts

1. Overcharge Detection

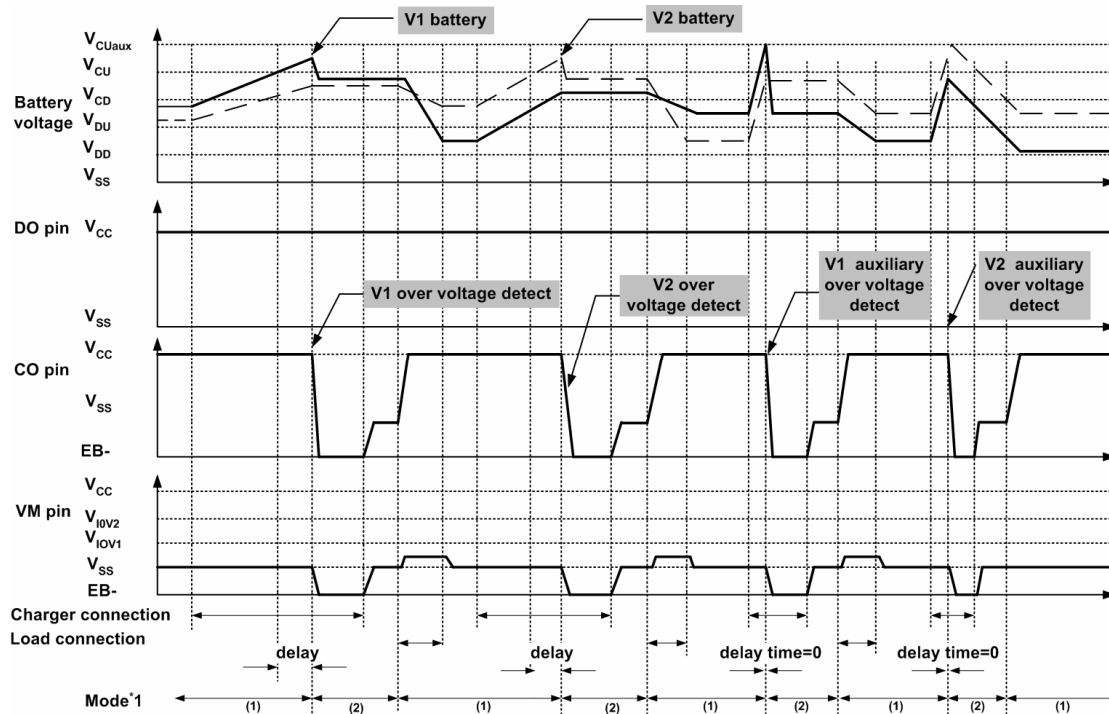

Figure18.

*1. <1> Normal mode. <2> Over charge mode.<3> Over discharge mode.<4> Over current mode.

Remark The charger is assumed to charge with a constant current.

2. Overdischarge Detection

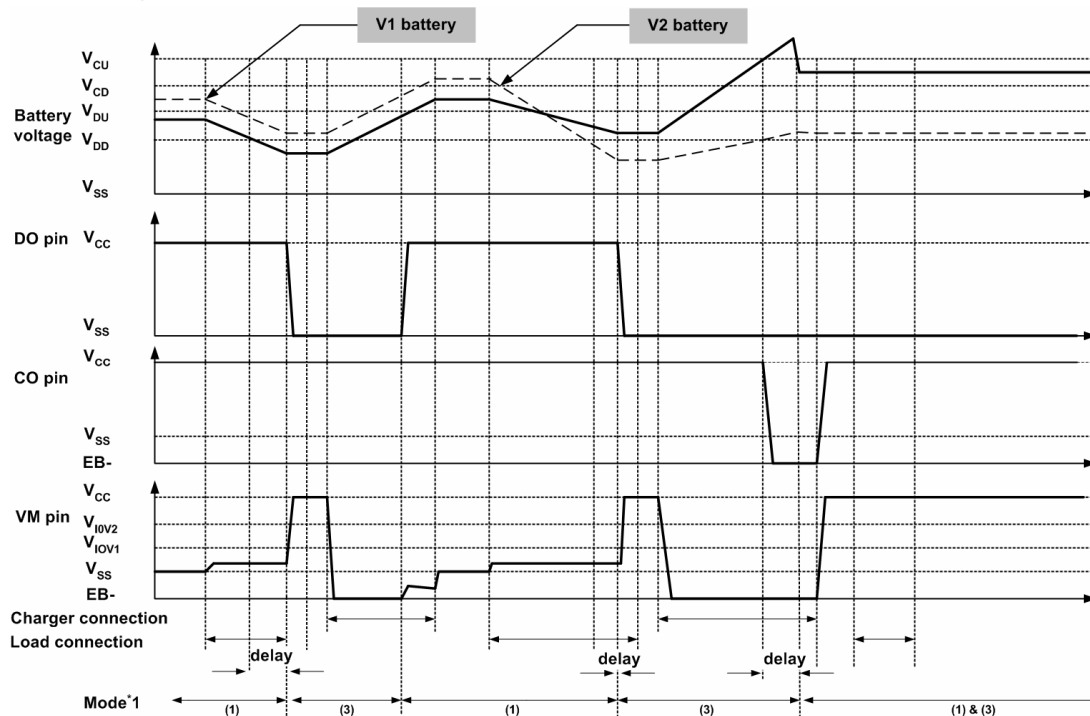

Figure19.

*1. <1> Normal mode. <2> Over charge mode.<3> Over discharge mode.<4> Over current mode.

Remark The charger is assumed to charge with a constant current.

3. Overcurrent Detection

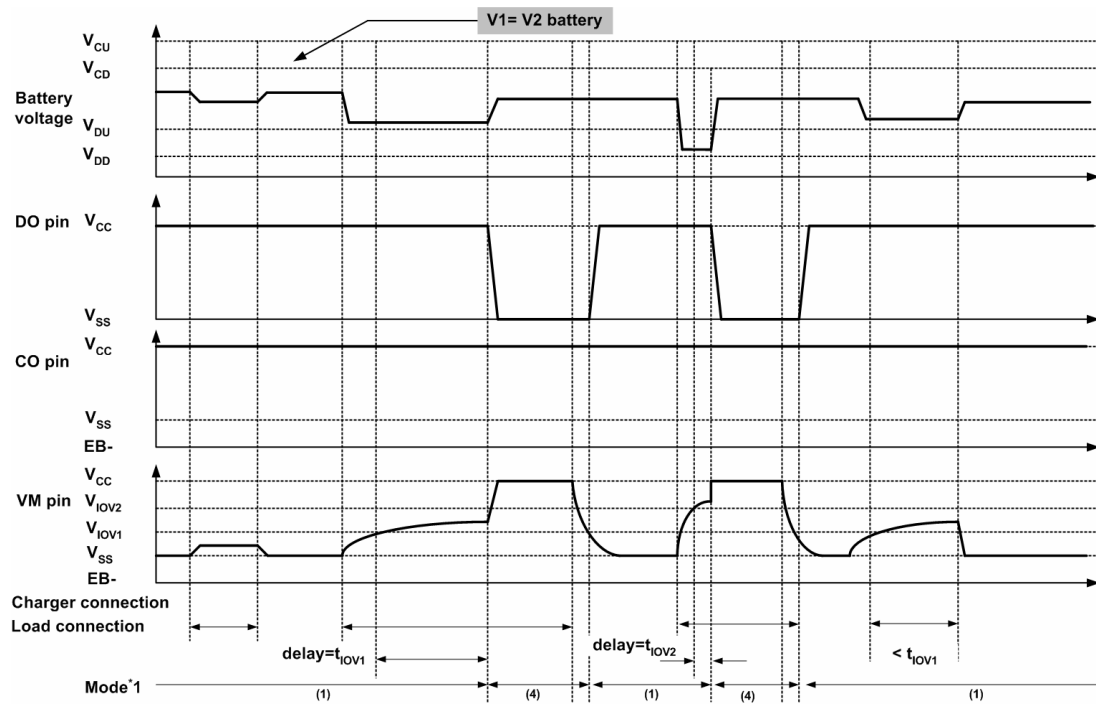

Figure20.

*1. <1> Normal mode. <2> Over charge mode.<3> Over discharge mode.<4> Over current mode.

Remark The charger is assumed to charge with a constant current.

Package Information

TSSOP-8

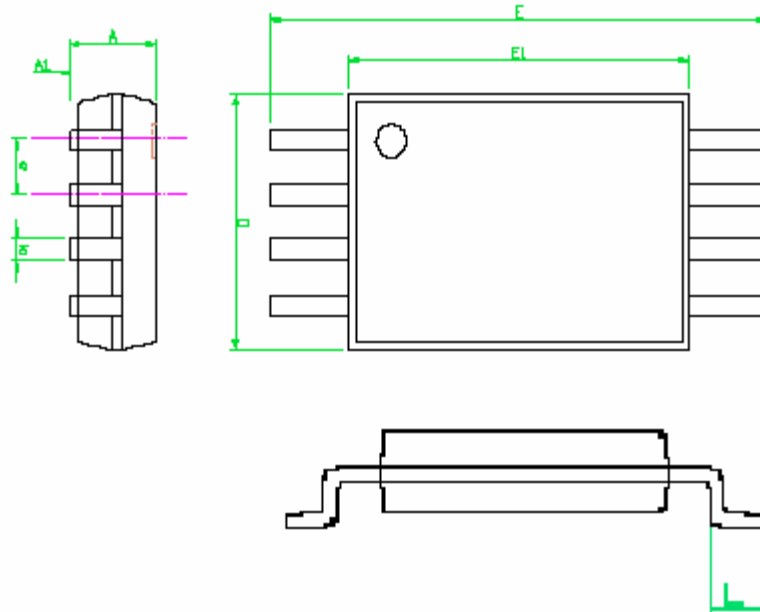

SYMBOLS	MILLIMETERS		INCHES	
	MIN.	MAX.	MIN.	MAX.
A	-	1.20	-	0.048
A1	0.00	0.15	0.000	0.006
b	0.19	0.30	0.007	0.012
D	3.00		0.118	
E	6.20	6.60	0.244	0.260
E1	4.40		0.173	
e	0.65		0.026	
L	0.45	0.75	0.018	0.030