

FAN8002D2

2-Channel Motor Drive

Features

- 2-Channel BTL driver with mute circuit
- Built-in 2-regulator
- Built-in 2-comparator
- Built-in thermal shutdown circuit
- Built-in mute circuit
- Built-in switch circuit
- Built-in OP-AMP circuit
- Operating supply voltage: 4.5~13.2V
- Corresponds to 3.6V DSP

Description

The FAN8002D is a monolithic integrated circuit, suitable for a 2-ch motor driver which drives the focus actuator, tracking actuator.

28-SSOPH-300



Ordering Information

Device	Package	Operating Temperature
FAN8002D2	28-SSOPH-300	-35°C ~ 85°C
FAN800D2TF	28-SSOPH-300	-35°C ~ 85°C

Pin Assignments

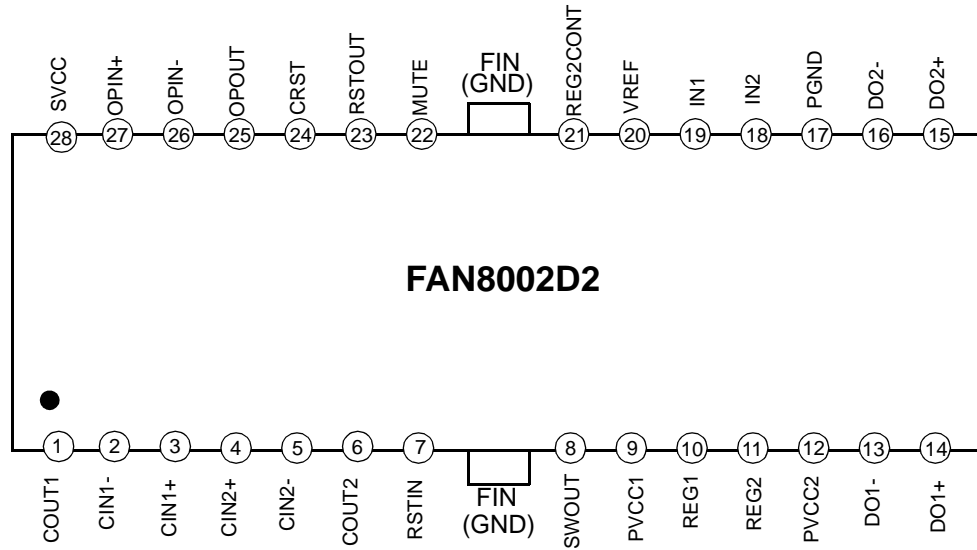

Pin Definitions

Pin Number	Pin Name	I/O	Pin Function Description
1	COUT1	O	Comparator1 Output
2	CIN1-	I	Comparator1 (-) Input
3	CIN1+	I	Comparator1 (+) Input
4	CIN2+	I	Comparator2 (+) Input
5	CIN2-	I	Comparator2 (-) Input
6	COUT2	O	Comparator2 Output
7	RSTIN	I	Reset Input
8	SWOUT	O	Switch Output
9	PVCC1	-	Power Supply1 (Reg,switch Part)
10	REG1	O	Regulator1 Output
11	REG2	O	Regulator2 Output
12	PVCC2	-	Power Supply 2 (Drive Power Output Part)
13	DO1-	O	Drive1 Output (-)
14	DO1+	O	Drive1 Output (+)
15	DO2+	O	Drive1 Output (+)
16	DO2-	O	Drive1 Output (-)
17	PGND	-	Power Ground
18	IN2	I	CH2 Drive Input
19	IN1	I	CH1 Drive Input
20	VREF	I	Reference Voltage
21	REG2 CONT	I	Regulator2 On/off Control
22	MUTE	I	Drive Mute

Pin Definitions (Continued)

Pin Number	Pin Name	I/O	Pin Function Description
23	RSTOUT	O	Reset Output
24	CRST	-	Reset Capacitor
25	OPOUT	-	Opamp Output
26	OPIN -	-	Opamp Input -
27	OPIN +	-	Opamp Input +
28	SVCC	-	Signal Supply (Comparator, Reset, Opamp Drive Pre-amp Part)

Block Diagram

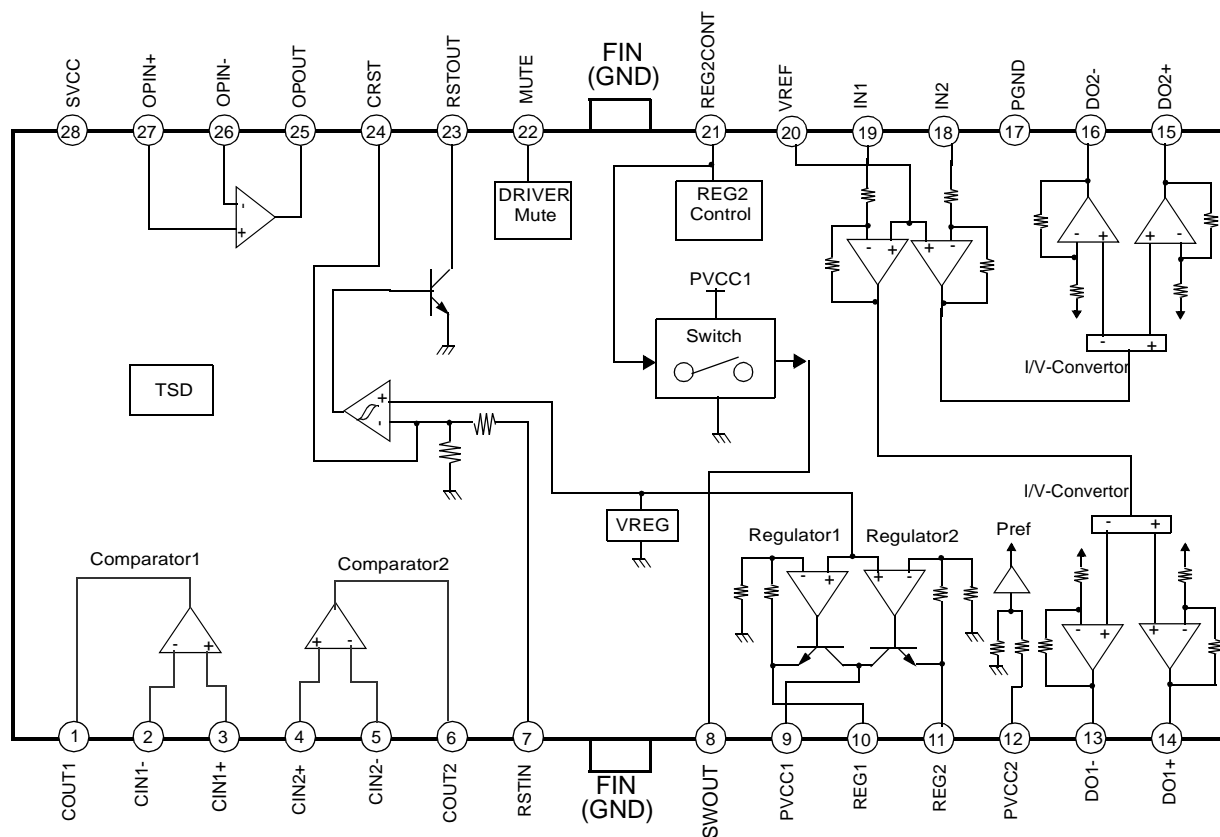

Equivalent Circuits

Comparator Output	Comparator Input
Reset Input & Reset Capacitor	Switch Output
Regulator Output	Btl Driver Output
Vref & Btl Driver Input	Reg2 & Switch Control Input

Equivalent Circuits (Continued)

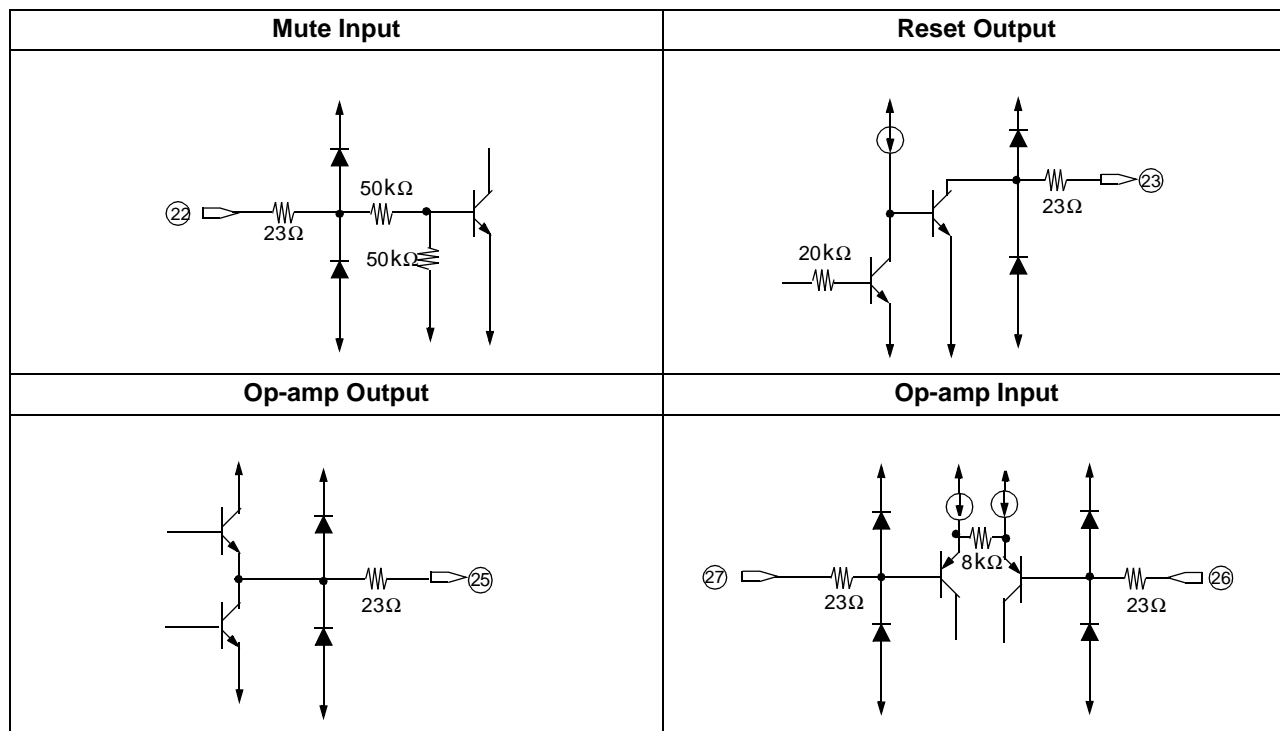

Absolute Maximum Ratings (Ta = 25 °C)

Parameter	Symbol	Value	Unit
Maximum supply voltage	V _{CCmax}	15	V
Power dissipation	P _d	1.4 ^{note}	W
Operating temperature range	T _{opr}	-35 ~ +85	°C
Storage temperature range	T _{stg}	-55 ~ +150	°C

NOTE:

1. When mounted on a 76.2mm × 114mm × 1.57mm PCB (Phenolic resin material).
2. Power dissipation reduces 11.2mW/°C for using above Ta = 25°C
3. Do not exceed P_d and SOA(Safe operating area).

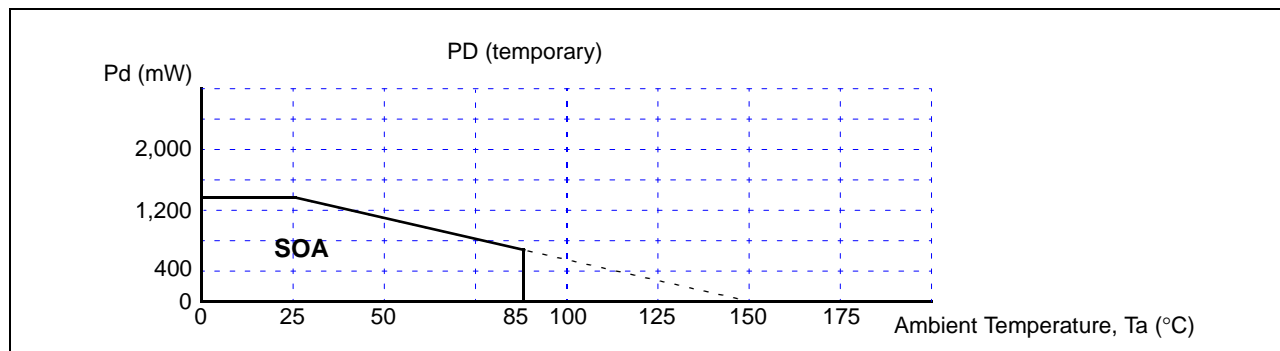

Recommended Operating Conditions

Parameter	Symbol	Min.	Typ.	Max.	Unit
Signal Supply Voltage	SVCC	4.5	-	13.2	V
Power Supply Voltage 1	PVCC1	4.5	-	SVCC	V
Power Supply Voltage 2	PVCC2	4.0	-	SVCC	V

Electrical Characteristics

(Unless otherwise specified, Ta = 25 °C, VCC = VM12 = VM3,4 = 5V, Vref=1.65V, Comparator out=Hi-Z)

Parameter	Symbol	Conditions	Min.	Typ.	Max.	Unit
Quiescent Current 1	ICC1	VIN =Vref, Pin21=0V, Pin22=5V	-	9	-	mA
Quiescent Current 2	ICC2	VIN = Vref, Pin21=5V, Pin22=5V	-	19	-	mA
Quiescent Current 3	ICC3	VIN = Vref, Pin21=5V, Pin22=0V	-	15	-	mA
Quiescent Current 4	Icc4	VIN = Vref, Pin21=0V, Pin22=0V	-	6	-	mA
DRIVE PART						
Output Offset Voltage	VOO	VIN = Vref	-50	-	+50	mV
Maximum output voltage1	VOM1	SVCC=5V, RL=24ohm,	3.1	3.5	-	V
Maximum output voltage2	VOM2	SVCC=12V, RL=24ohm	3.6	4.0	-	V
Closed loop voltage gain	GVC	VIN=0.1Vrms, f=1KHz, Rext=0	10.5	12	13.5	dB
Mute on voltage	VMON	Pin22 = Variation	GND	-	0.5	V
Mute off voltage	VMOFF	Pin22 = Variation	2	-	Vcc	V
REGULATOR PART						
Maximum output current	Iomax	-	200	-	-	mA
Regulator output voltage	Vreg	IL=50mA	3.5	3.6	3.7	V
Load regulation	ΔVrl	IL=0~200mA	-40	-	10	mV
Line regulation	ΔVcc	VCC=4.5~5.5V	-	10	30	mV
Regulator2 on voltage	Vr2on	Pin21=Variation	2.0	-	Vcc	V
Regulator2 off voltage	Vr2off	Pin21=Variation	GND	-	0.5	V
COMPARATOR PART						
Input offset voltage	Vio	-	-	-	4.0	mV
Input offset current	Iio	-	-	5.0	-	nA
Input bias current	Ib	-	-	25	250	nA
Common mode input voltage	Vicm	-	0	-	3.5	V
Output sink current	Isink	-	3.0	-	-	mA
Slew rate	SR	VIN=4Vp_p, f=100KHz, Square	-	1.3	-	us
RESET PART						
Reset on voltage	Vrston	VCTI=H / L	4.1	4.2	4.3	V
Reset hysteresis voltage	Vrsthys	VCTI=H / L /H	100	-	200	mV
Low level output voltage	VoL	RL=4.7 K	-	100	200	mV
SWITCH PART						
Upper saturation voltage	Vupsat	VCC=5V, Iout=150mA	-	0.13	0.2	V
Output off current	Ioff	VCC=5V	-	-	20	μA
OP-AMP PART						

Electrical Characteristics (Continued)

(Unless otherwise specified, $T_a = 25\text{ }^\circ\text{C}$, $V_{CC} = V_{M12} = V_{M3,4} = 5\text{V}$, $V_{ref} = 1.65\text{V}$, Comparator out=Hi-Z

Parameter	Symbol	Conditions	Min.	Typ.	Max.	Unit
Input offset voltage	VOF	-	-7	0	+7	mV
Input bias current	IB1	-	-	-	200	nA
High level output voltage	VOH1	-	4.4	4.7	-	V
Low level output voltage	VOL1	-	-	0.1	0.4	V
Output sink current	ISINK	$R_L = 1\text{Kohm}$	2	4	-	mA
Output source current	ISOU1	$R_L = 1\text{Kohm}$	2	4	-	mA
Common mode input range	VICM	-	-0.3	-	4.0	V
Open Loop voltage gain	GVO1	$f = 1\text{kHz}$, $V_{IN} = -75\text{dB}$	-	80	-	dB
Ripple rejection ratio	RR1	$f = 120\text{Hz}$, $V_{IN} = -20\text{dB}$	-	65	-	dB
slew rate	SR1	$f = 120\text{Hz}$, 2Vp-p	-	1.2	-	V/us
Common Mode rejection ratio	CMRR	$f = 1\text{kHz}$, $V_{IN} = -20\text{dB}$	-	80	-	dB

Application Information

1. Reference Input

Pin 20 (REF) is a reference Input pin.

- Reference Input
The applied voltage at the reference input pin must be between 1.5 (V) and 3.5 (V), when $V_{CC} = 5V$.

2. Channel Mute Function

These pins are used for channel mute operation.

- When the mute pin (pin22) is Low level, the mute circuit is enabled and the output circuits are muted.(both CH1, CH2)
- When the voltage of the mute pin (pin22) is High level, the mute circuit is disabled and the output circuits operate normally.
- If the chip temperature rises above 175 °C, then the thermal shutdown (TSD) circuit is activated and the output circuits are muted.
- Mute(pin 22)-CH1, 2 mute control input pin.

3. Protection Function

Thermal Shutdown (TSD)

- 1) If the chip temperature rises above 175 °C the thermal shutdown (TSD) circuit is activated and the output circuit is in the Mute state, that is Off state.
- The TSD circuit has a temperature hysteresis of 25°C.

4. Focus, Tracking Actuator

- The reference voltage REF is given externally through pin 20
- The input signal is amplified by $R2/R1$ times and then fed to the level shift circuit.
- The level shift circuit produces the differential output voltages and drives the two output power amplifiers.
Since the differential gain of the output amplifiers is equal to $2 \times (1 + R4/R3)$, the input signal is amplified by $(R2/R1) \times 2 \times (1 + R4/R3)$.
- If the total gain is too high, you can reduce the closed loop gain by adding an external resistance at pin18, 19
- The power reference voltage (V_r) is about a half of the supply voltage(V_M).

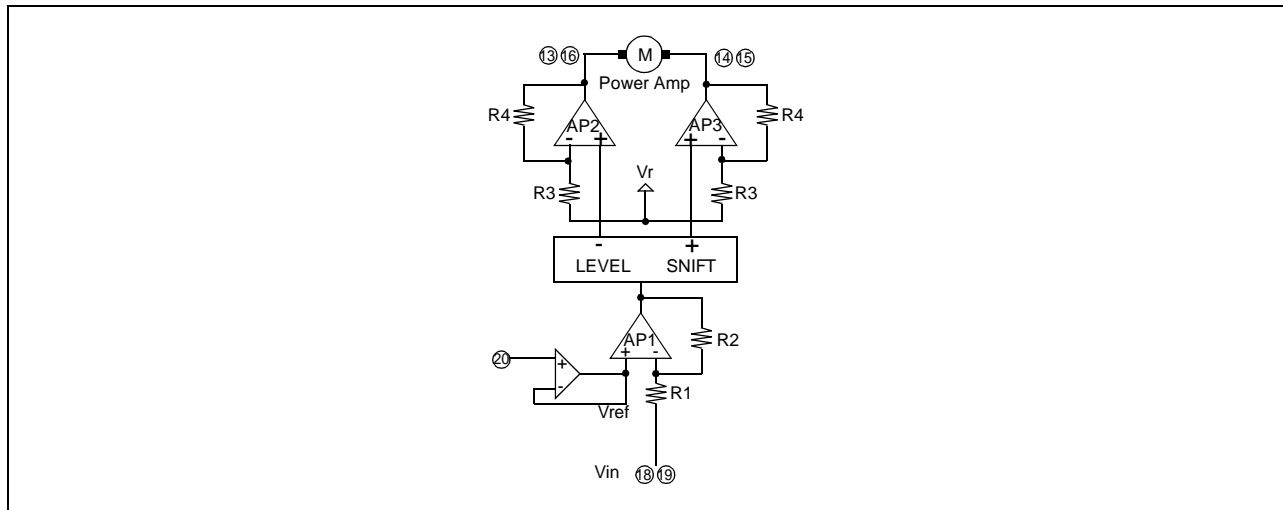

5. Regulator & Control Function

The regulator circuit is illustrated in the figure.1.

- The capacitor is used as a ripple eliminator and should have a good temperature characteristics.
- The regulator output voltage is calculated as follows

$$V_{REG} = (1 + R1/R2) \times 2.5 = 3.4V$$

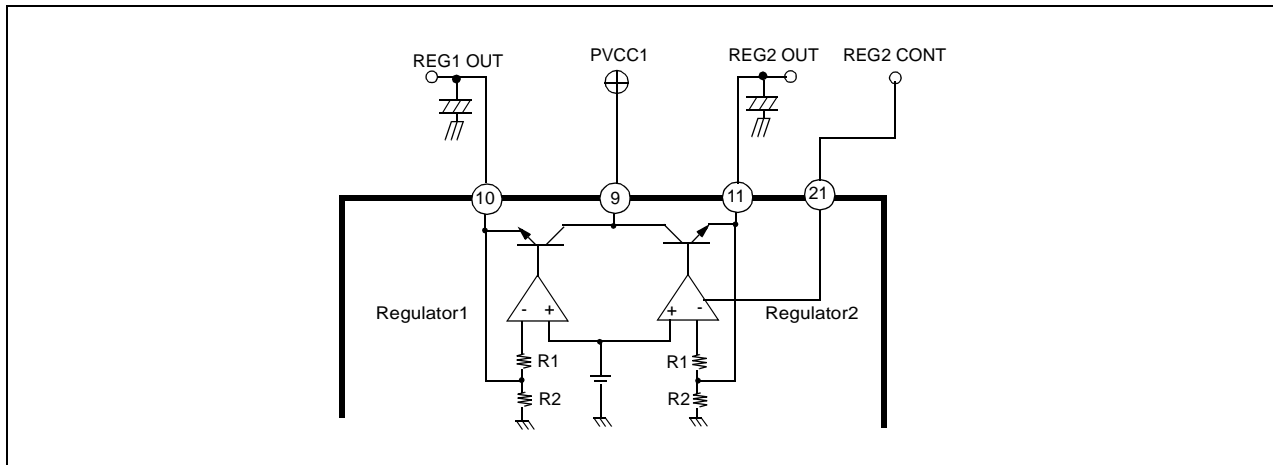

Figure 1.

- When the voltage of the pin21 is high (above 2.0V), the regulator operates normally.
On the other hand, when the voltage of the pin21 is low (below 0.5V), the regulator will be turned off.
Truth table is as follows

Pin#21	Regulator 2
High	Turn On
Low	Turn Off

6. Reset Circuit

The reset circuit is illustrated in the figure.2.

- 1) The capacitor is used for delay.

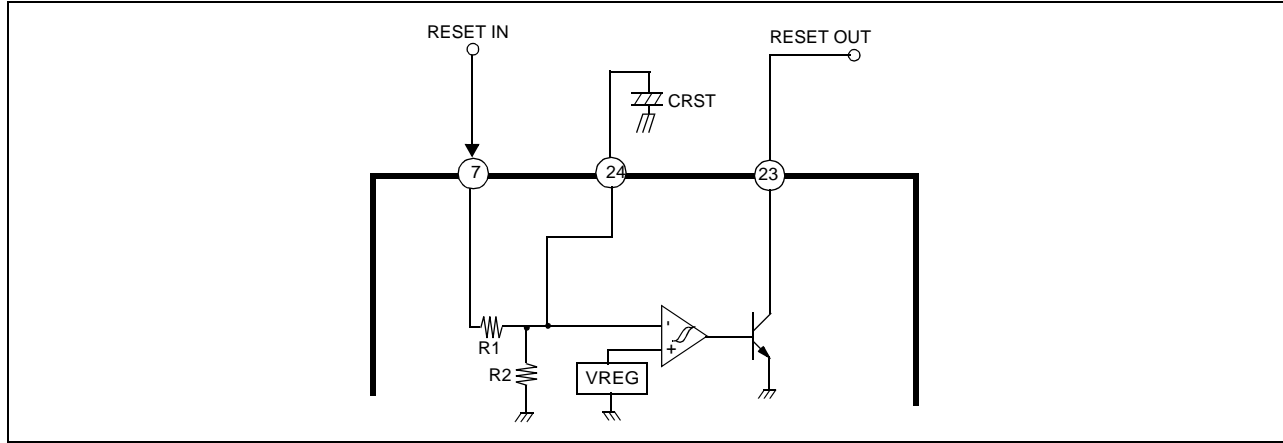

Figure 2.

- 2) When the voltage of the pin7 is above 4.2V, the output of the reset circuit is OPEN (no load). On the other hand, when the voltage of the pin7 is low , the output of the reset circuit is low.

Truth table is as follows

Pin#7	Reset Output
High	Open
Low	Low

7. Switch Circuit

The switch circuit is illustrated in the figure.3.

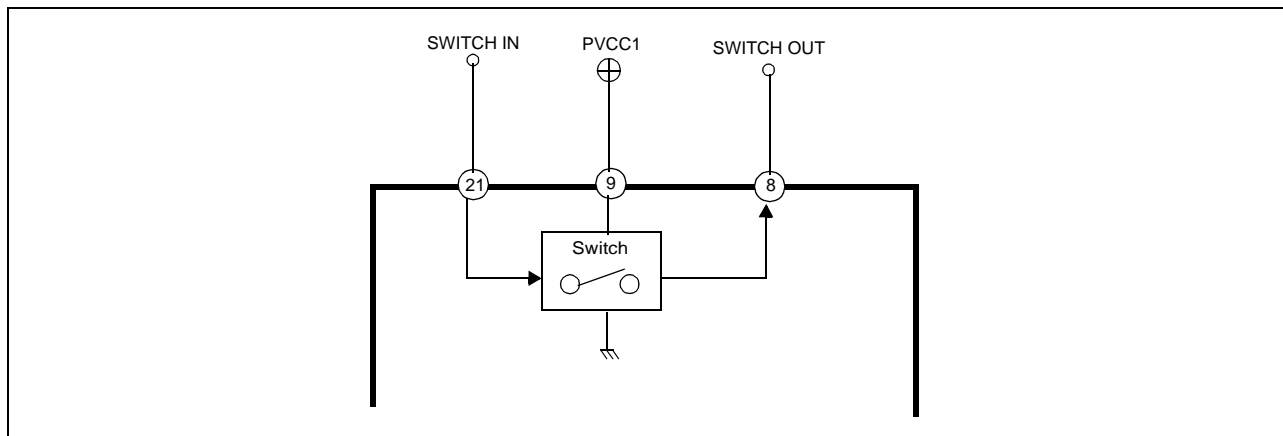

When the voltage of the pin21 is high (above 2.0V), the output of the switch circuit is above 4.8V. On the other hand, when the voltage of the pin21 is low (below 0.5V), the routput of the reset circuit is below 0.5V.

Truth table is as follows

Pin#21	Switch Output
High	Above 4.8v
Low	Below 0.5v

The regulator2 control pin and the switch control pin is same(pin21).
If the pin21 is high, first switch circuit operates and then regulator circuit operates normally.
The operation is illustrated in the following time table

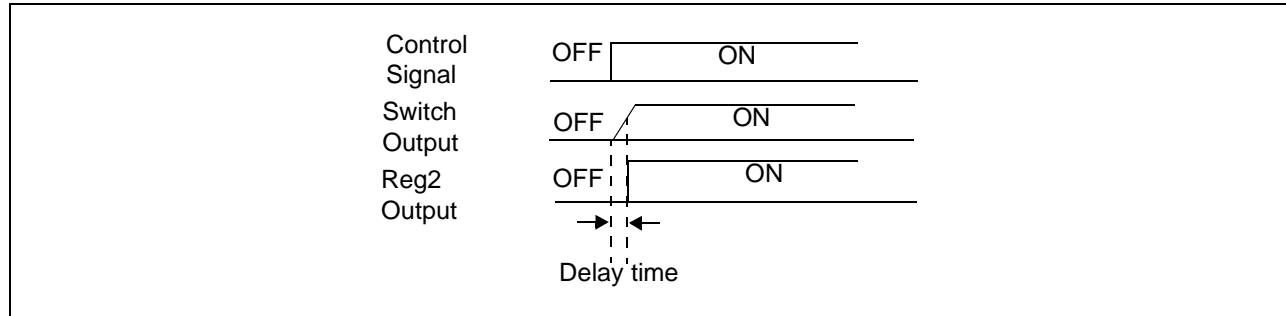

Test Circuit

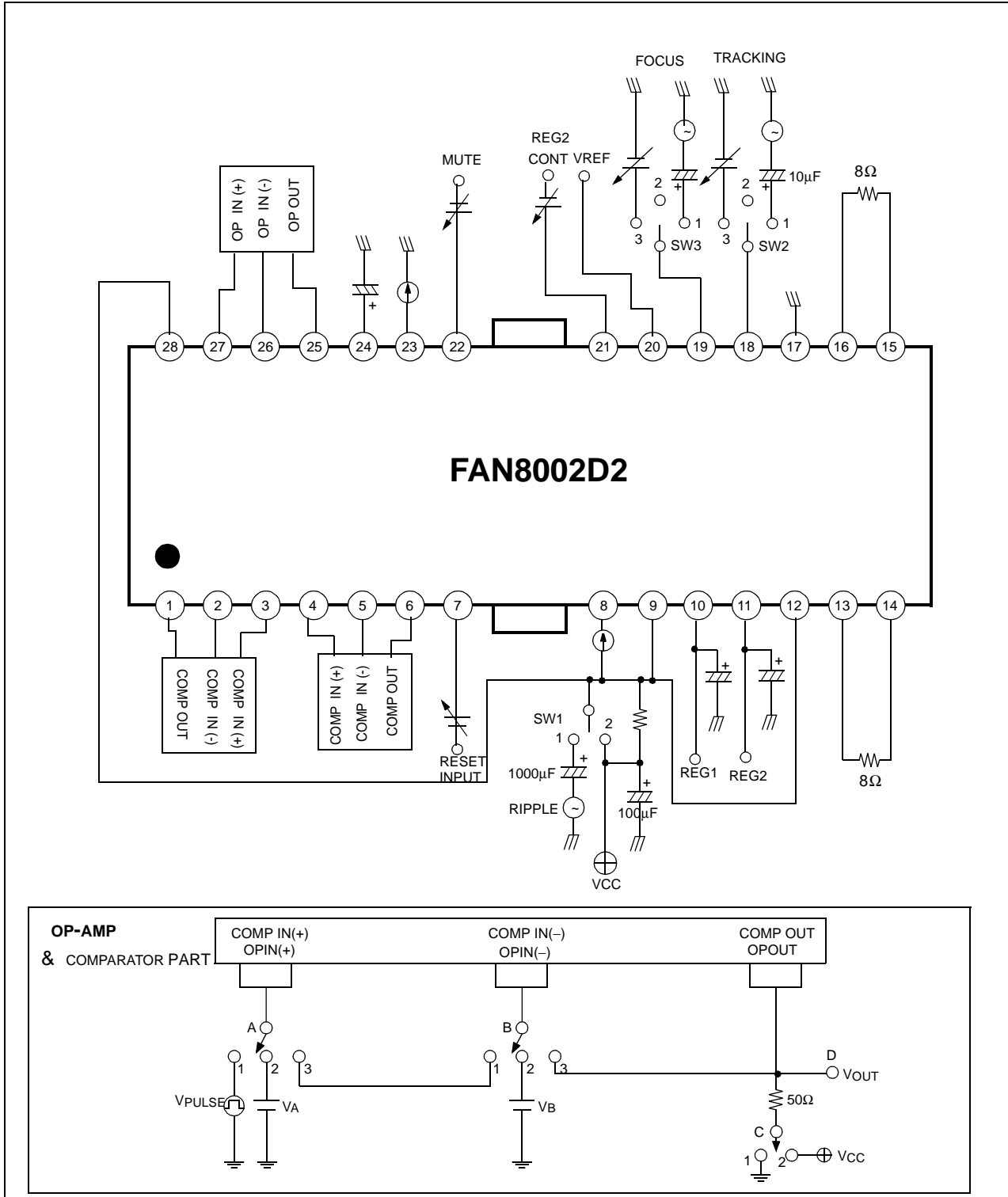

Application Circuit

(Voltage Control Mode)

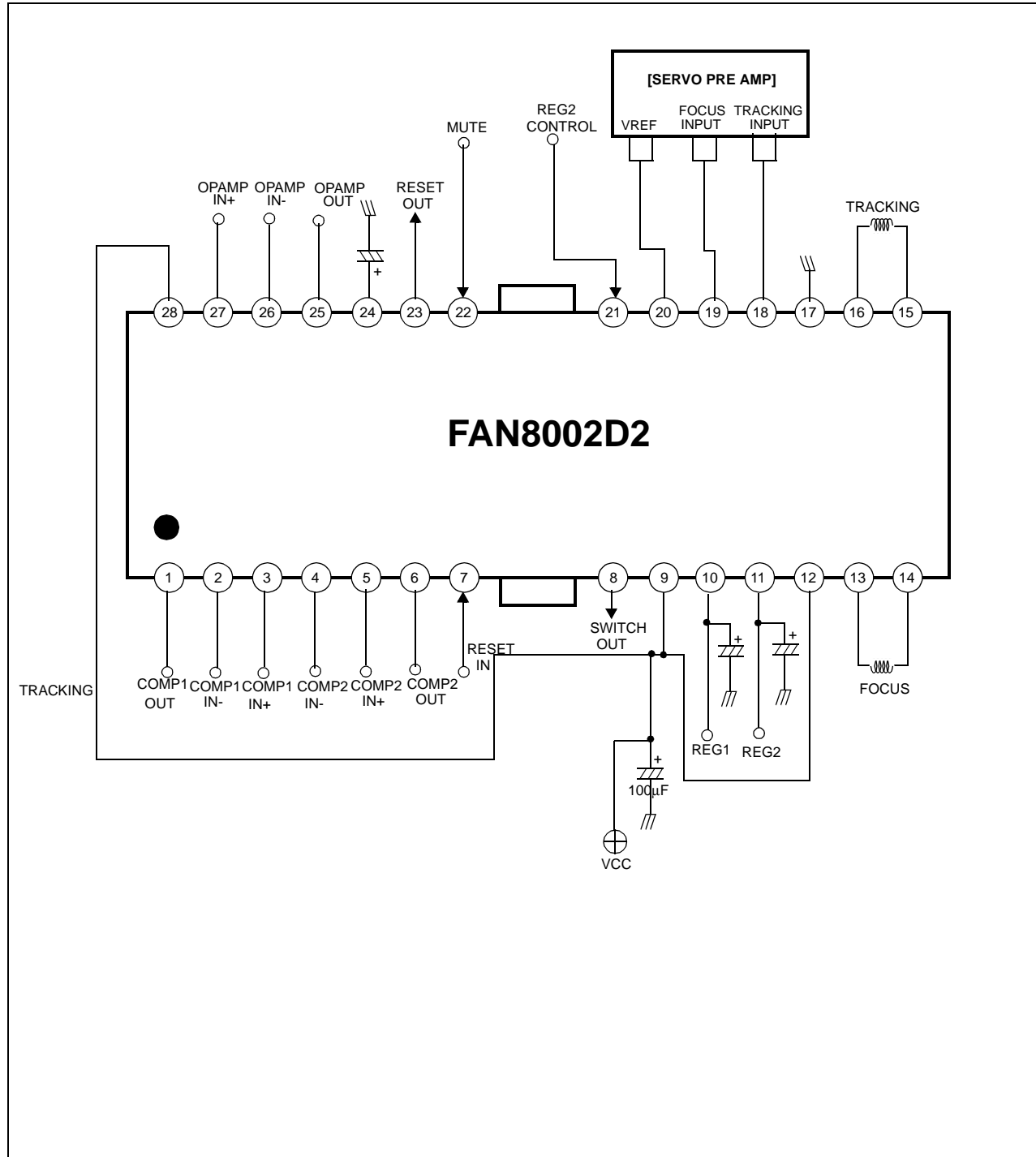

DISCLAIMER

FAIRCHILD SEMICONDUCTOR RESERVES THE RIGHT TO MAKE CHANGES WITHOUT FURTHER NOTICE TO ANY PRODUCTS HEREIN TO IMPROVE RELIABILITY, FUNCTION OR DESIGN. FAIRCHILD DOES NOT ASSUME ANY LIABILITY ARISING OUT OF THE APPLICATION OR USE OF ANY PRODUCT OR CIRCUIT DESCRIBED HEREIN; NEITHER DOES IT CONVEY ANY LICENSE UNDER ITS PATENT RIGHTS, NOR THE RIGHTS OF OTHERS.

LIFE SUPPORT POLICY

FAIRCHILD'S PRODUCTS ARE NOT AUTHORIZED FOR USE AS CRITICAL COMPONENTS IN LIFE SUPPORT DEVICES OR SYSTEMS WITHOUT THE EXPRESS WRITTEN APPROVAL OF THE PRESIDENT OF FAIRCHILD SEMICONDUCTOR INTERNATIONAL. As used herein:

1. Life support devices or systems are devices or systems which, (a) are intended for surgical implant into the body, or (b) support or sustain life, and (c) whose failure to perform when properly used in accordance with instructions for use provided in the labeling, can be reasonably expected to result in a significant injury of the user.
2. A critical component in any component of a life support device or system whose failure to perform can be reasonably expected to cause the failure of the life support device or system, or to affect its safety or effectiveness.