

> Features

- High Speed Switching
- Low On-Resistance
- No Secondary Breakdown
- Low Driving Power
- High Voltage
- $V_{GS} = \pm 30V$ Guarantee
- Repetitive Avalanche Rated

> Applications

- Switching Regulators
- UPS
- DC-DC converters
- General Purpose Power Amplifier

> Maximum Ratings and Characteristics

- Absolute Maximum Ratings ($T_C=25^\circ C$), unless otherwise specified

Item	Symbol	Rating	Unit
Drain-Source-Voltage	V_{DS}	500	V
Continous Drain Current	I_D	14	A
Pulsed Drain Current	$I_{D(puls)}$	56	A
Gate-Source-Voltage	V_{GS}	± 30	V
Avalanche Current	I_{AR}	14^{*2}	A
Maximum Avalanche Energy	E_{AS}	760^{*1}	mJ
Max. Power Dissipation	P_D	190	W
Operating and Storage Temperature Range	T_{ch}	150	$^\circ C$
	T_{stg}	-55 ~ +150	$^\circ C$

*1) $V_{CC} = 50V$; $L = 7mH$; $I_{AS} = 14A$; $R_G = 50 \Omega$; Starting $T_{ch} = 25^\circ C$ (See Fig. 1 & 2)

*2) Repetitive Rating : Pulse Width limited by max. Channel Temperature

- Electrical Characteristics ($T_C=25^\circ C$), unless otherwise specified

Item	Symbol	Test conditions	Min.	Typ.	Max.	Unit
Drain-Source Breakdown-Voltage	BV_{DSS}	$I_D=1mA$ $V_{GS}=0V$	500			V
Gate Threshold Voltage	$V_{GS(th)}$	$I_D=250\mu A$ $V_{DS}=V_{GS}$	3,0	3,0	4,0	V
Zero Gate Voltage Drain Current	I_{DSS}	$V_{DS}=500V$ $T_{ch}=25^\circ C$			25	μA
		$V_{GS}=0V$ $T_{ch}=125^\circ C$			1,0	mA
Gate Source Leakage Current	I_{GSS}	$V_{GS}=\pm 30V$ $V_{DS}=0V$		10	100	nA
Drain Source On-State Resistance	$R_{DS(on)}$	$I_D=8A$ $V_{GS}=10V$		0,32	0,38	Ω
Forward Transconductance	g_{fs}	$I_D=8A$ $V_{DS}=25V$	7	14		S
Input Capacitance	C_{iss}	$V_{DS}=25V$		2200		pF
Output Capacitance	C_{oss}	$V_{GS}=0V$		330		pF
Reverse Transfer Capacitance	C_{rss}	$f=1MHz$		140		pF
Turn-On-Time t_{on} ($t_{on}=t_{d(on)}+t_r$)	$t_{d(on)}$	$V_{CC}=250V$		18		ns
	t_r	$V_{GS}=10V$		70		ns
Turn-Off-Time t_{off} ($t_{off}=t_{d(off)}+t_f$)	$t_{d(off)}$	$R_G = 6,1W$		130		ns
	t_f	$R_D = 20\Omega$		70		ns
Avalanche Capability	I_{AV}	$L = 100\mu H$ $T_{ch}=25^\circ C$	4			A
Total Gate Charge	C_{iss}	$V_{CC}=400V$			170	nC
Gate-Source Charge	C_{oss}	$V_{GS}=10V$			20	nC
Gate-Drain Charge	C_{rss}	$I_D = 14A$			90	nC
Diode Forward On-Voltage	V_{SD}	$I_F=2I_{DR}$ $V_{GS}=0V$ $T_{ch}=25^\circ C$		1,0	1,5	V
Reverse Recovery Time	t_{rr}	$I_F=I_{DR}$ $V_{GS}=0V$		700		ns
Reverse Recovery Charge	Q_{rr}	$-dI_F/dt=100A/\mu s$ $T_{ch}=25^\circ C$		9,0		μC

- Thermal Characteristics

Item	Symbol	Test conditions	Min.	Typ.	Max.	Unit
Thermal Resistance	$R_{th(ch-a)}$	channel to ambient			35	$^\circ C/W$
	$R_{th(ch-c)}$	channel to case			0,65	$^\circ C/W$

> Outline Drawing

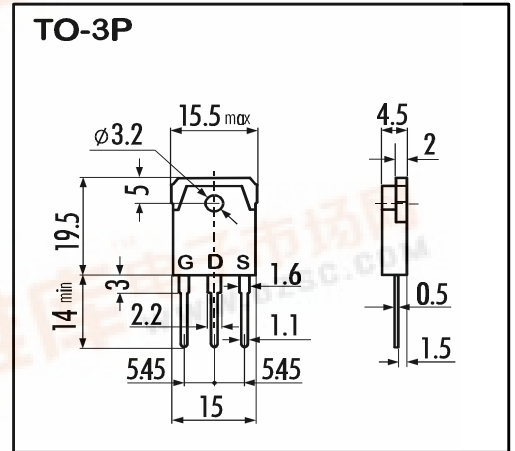

> Equivalent Circuit

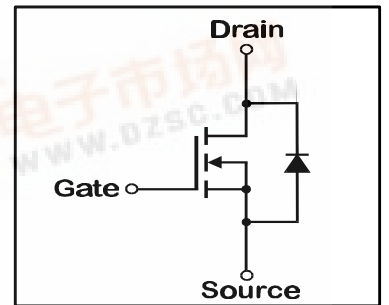

N-channel MOS-FET			
500V	0,38Ω	14A	190W

FAP-450

FAP-IIS Series



> Characteristics

Typical Output Characteristics
 $I_D = f(V_{DS}); 80\mu s$ pulse test; $T_C = 25^\circ C$

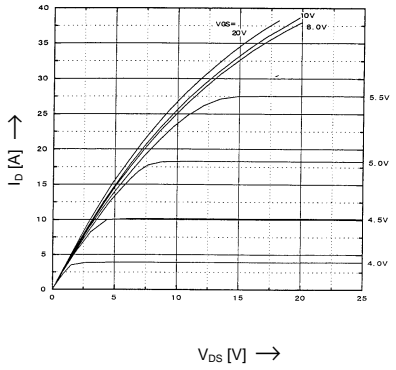

Drain-Source-On-State Resistance vs. T_{ch}
 $R_{DS(on)} = f(T_{ch}); I_D = 8A; V_{GS} = 10V; 80\mu s$ pulse test

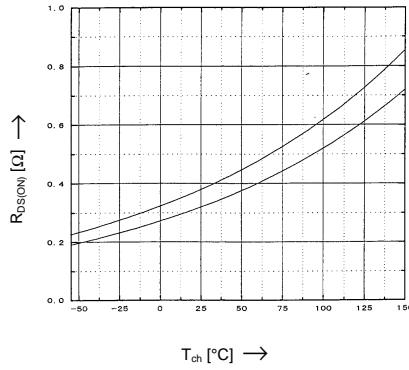

Typical Transfer Characteristics
 $I_D = f(V_{GS}); 80\mu s$ pulse test; $V_{DS} = 25V; T_{ch} = 25^\circ C$

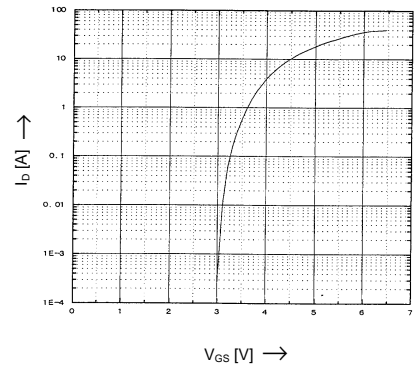

Typical Drain-Source-On-State-Resistance vs. I_D
 $R_{DS(on)} = f(I_D); 80\mu s$ pulse test; $T_C = 25^\circ C$

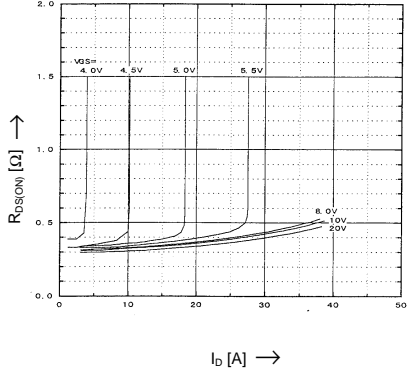

Typical Forward Transconductance vs. I_D
 $g_{fs} = f(I_D); 80\mu s$ pulse test; $V_{DS} = 25V; T_{ch} = 25^\circ C$

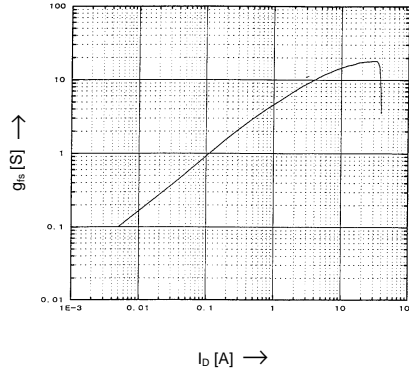

Gate Threshold Voltage vs. T_{ch}
 $V_{GS(th)} = f(T_{ch}); I_D = 250\mu A; V_{DS} = V_{GS}$

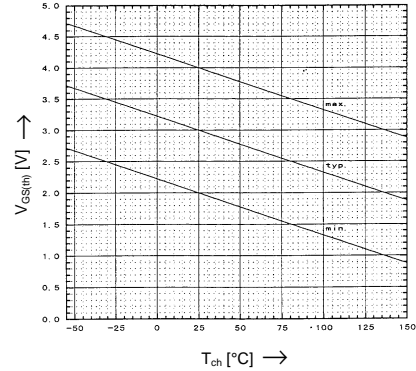

Typical Capacitances vs. V_{DS}
 $C = f(V_{DS}); V_{GS} = 0V; f = 1MHz$

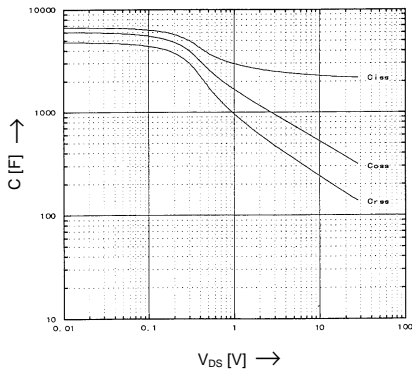

Max. Avalanche Energy Derating
 vs. Starting Channel Temperature
 $E_{as} = f(\text{starting } T_{ch}); \text{Peak } I_L = 14A; V_{CC} = 50V$

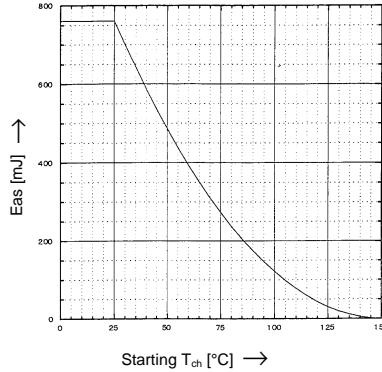

Forward Characteristics of Reverse Diode
 $I_F = f(V_{SD}); 80\mu s$ pulse test; $V_{GS} = 0V$

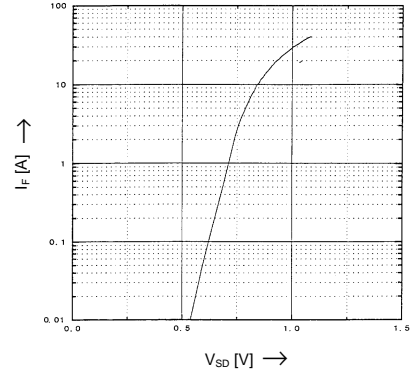

Allowable Power Dissipation vs. T_C
 $P_D = f(T_C)$

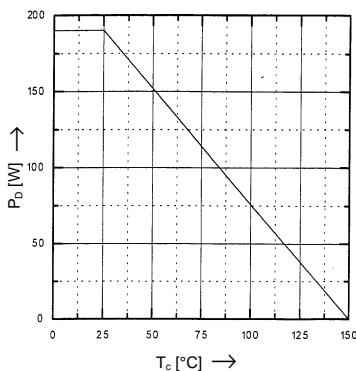

Safe Operation Area
 $I_D = f(V_{DS}); \text{Single Pulse}; T_C = 25^\circ C$

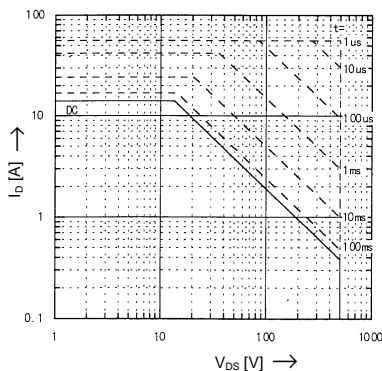

Transient Thermal impedance
 $Z_{th(ch-c)} = f(t); D = t/T$

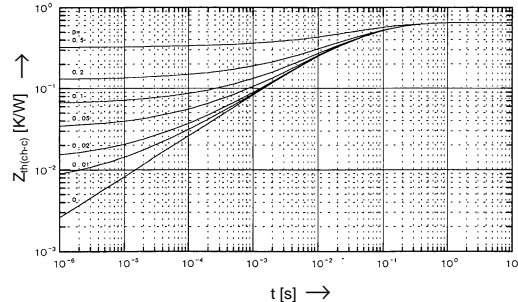

N-channel MOS-FET			
500V	0,38Ω	14A	190W

FAP-450

FAP-IIS Series



> Characteristics

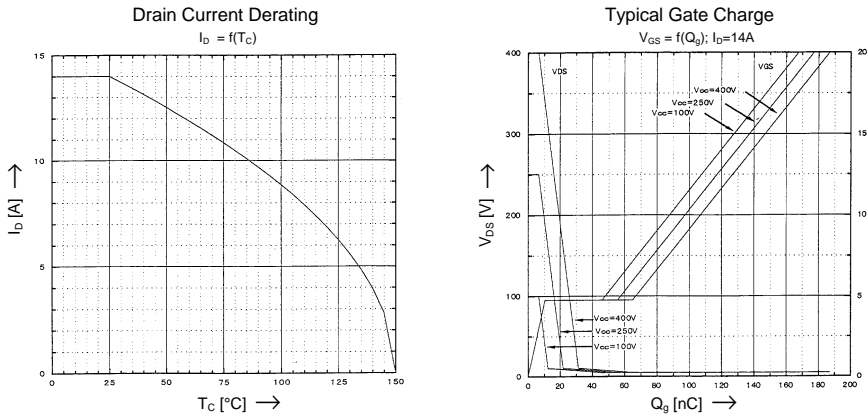

Fig. 1: Test Circuit

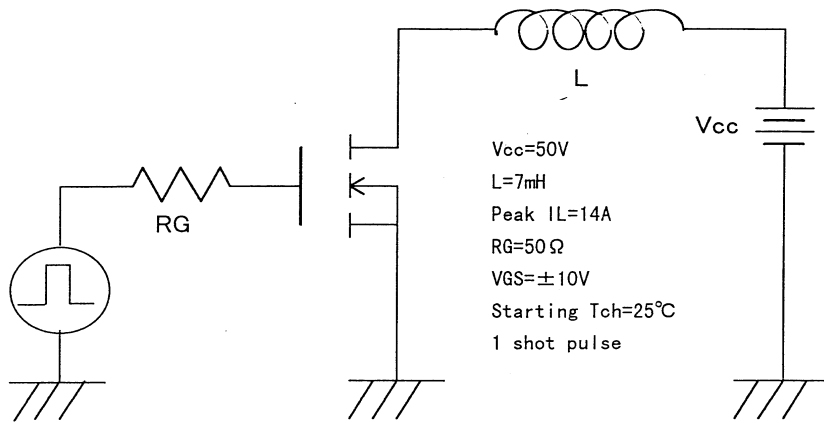

Fig. 2: Operating Waveforms

