



FBR5000 - FBR5010

PRV : 50 - 1000 Volts
Io : 50 Amperes

FEATURES :

- * High case dielectric strength
- * High surge current capability
- * High reliability
- * Low reverse current
- * Low forward voltage drop
- * Fast switching for high efficiency

MECHANICAL DATA :

- * Case : Molded plastic with heatsink integrally mounted in the bridge encapsulation
- * Epoxy : UL94V-O rate flame retardant
- * Terminals : plated .25" (6.35 mm). Faston
- * Polarity : Polarity symbols marked on case
- * Mounting position : Bolt down on heat-sink with silicone thermal compound between bridge and mounting surface for maximum heat transfer efficiency.
- * Weight : 17.1 grams

FAST RECOVERY BRIDGE RECTIFIERS

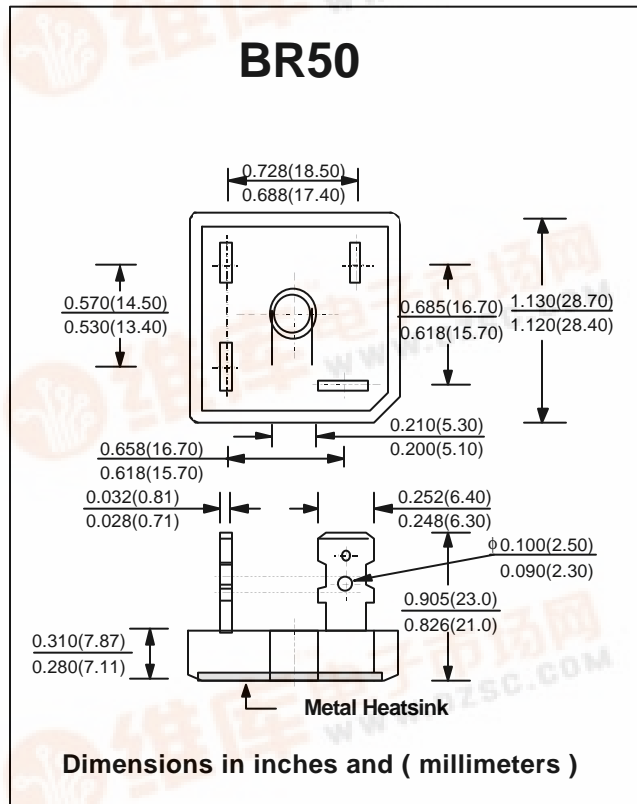

MAXIMUM RATINGS AND ELECTRICAL CHARACTERISTICS

Rating at 25 °C ambient temperature unless otherwise specified.
Single phase, half wave, 60 Hz, resistive or inductive load.
For capacitive load, derate current by 20%.

RATING	SYMBOL	FBR 5000	FBR 5001	FBR 5002	FBR 5004	FBR 5006	FBR 5008	FBR 5010	UNIT
Maximum Recurrent Peak Reverse Voltage	V _{RRM}	50	100	200	400	600	800	1000	Volts
Maximum RMS Voltage	V _{RMS}	35	70	140	280	420	560	700	Volts
Maximum DC Blocking Voltage	V _{DC}	50	100	200	400	600	800	1000	Volts
Maximum Average Forward Current T _c = 55 °C	I _{F(AV)}	50							Amps.
Peak Forward Surge Current Single half sine wave Superimposed on rated load (JEDEC Method)	I _{FSM}	400							Amps.
Current Squared Time at t < 8.3 ms.	∫ ² t	664							A ² S
Maximum Forward Voltage drop per Diode at I _F = 25 Amps.	V _F	1.3							Volts
Maximum DC Reverse Current Ta = 25 °C at Rated DC Blocking Voltage Ta = 100 °C	I _R	10							µA
	I _{R(H)}	1.0							mA
Maximum Reverse Recovery Time (Note 1)	T _{rr}	200			300	500		ns	
Typical Thermal Resistance per diode (Note 2)	RθJC	1							°C/W
Operating Junction Temperature Range	T _J	- 50 to + 150							°C
Storage Temperature Range	T _{STG}	- 50 to + 150							°C

Notes :

- 1) Measured with I_F = 0.5 Amp., I_R = 1 Amp., I_{rr} = 0.25 Amp.
- 2) Thermal resistance from Junction to Case with units mounted on a 9"x5"x4.6" (22.9x12.7x11.7 cm) Al-Finned Heatsink.

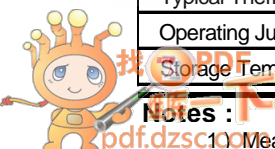

RATING AND CHARACTERISTIC CURVES (FBR5000 - FBR5010)

FIG.1 - REVERSE RECOVERY TIME CHARACTERISTIC AND TEST CIRCUIT DIAGRAM

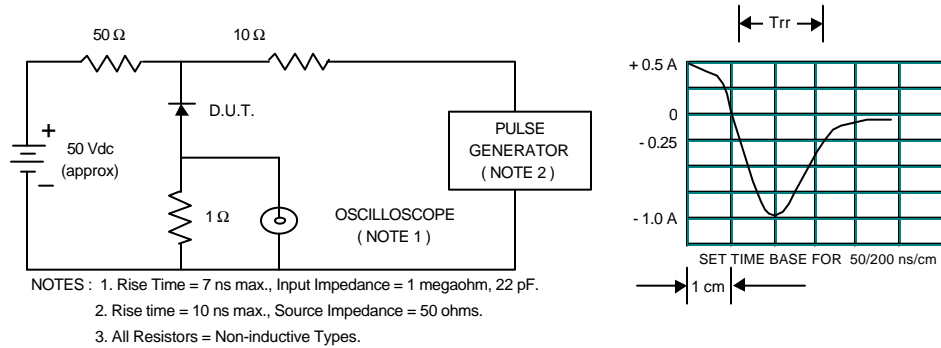

FIG.2 - DERATING CURVE FOR OUTPUT RECTIFIED CURRENT

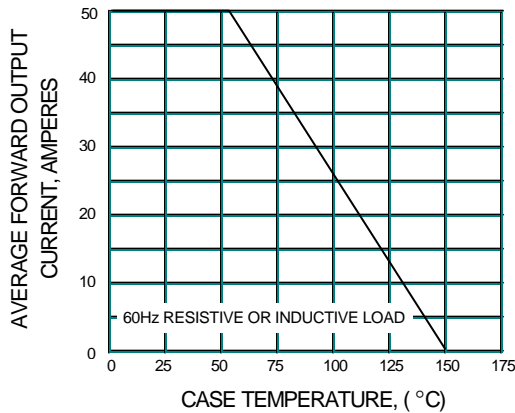

FIG.3 - MAXIMUM NON-REPETITIVE PEAK FORWARD SURGE CURRENT

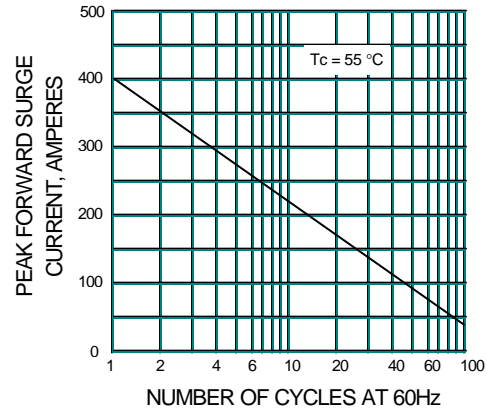

FIG.4 - TYPICAL FORWARD CHARACTERISTICS PER DIODE

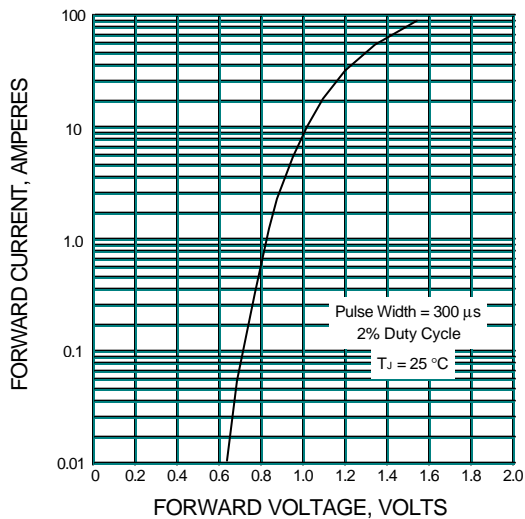

FIG.5 - TYPICAL REVERSE CHARACTERISTICS PER DIODE

