



**POWER MATE
TECHNOLOGY CO.,LTD.**

FDC40-SERIES



Patent No. 460344

- 40 WATTS OUTPUT POWER
- 2:1 WIDE INPUT VOLTAGE RANGE
- DESIGN MEET SAFETY STANDARD
- SIX-SIDED CONTINUOUS SHIELD
- HIGH EFFICIENCY UP TO 90%
- STANDARD 3" X 2.6" X 0.4" PACKAGE
- FIXED SWITCHING FREQUENCY

The FDC40 series offer 40 Watts of output power from a 3 x 2.6 x 0.4 inch package. The FDC40 series have 2:1 wide input voltage of 9-18, 18-36 and 36-75VDC. The FDC40 features 1600VDC of isolation, short-circuit and over-voltage protection, as well as six sided shielding. Designed meets the safety of EN60950 and UL1950. All models are particularly suited to telecommunications, industrial, mobile telecom and test equipment applications.

TECHNICAL SPECIFICATION

All specifications are typical at nominal input, full load and 25°C otherwise noted

OUTPUT SPECIFICATIONS		
Output power		40 Watts max
Voltage accuracy Full load and nominal Vin	Single & Dual	± 2%
	Triple 3.3V/5V	± 2%
	Auxiliary	± 5%
Voltage adjustability		± 10%
Minimum load (Note 1)	FDC40-XXD3305 3.3V output	20% min
	Others	10% of FL
Line regulation LL to HL at Full Load	Single	± 0.5%
	Dual	± 1%
	Triple 3.3V/5V	± 2%
	Auxiliary	± 5%
Load regulation 10% to 100% FL	Single	± 0.5%
	Dual	± 1%
	Triple 3.3V/5V	± 2%
	Auxiliary	± 5%
Cross regulation (Note 2)	Dual	± 1%
	Triple 3.3V/5V	± 1%
	Auxiliary	± 5%
Ripple and noise	20MHz bandwidth	1%/p-p of Vout max
Temperature coefficient		±0.02% / °C, max
Transient response recovery time	25% load step change	500uS
Over voltage protection	3.3V output	3.9V
	5V output	6.2V
	Zener diode clamp 12V output	15V
	15V output	18V
Short circuit protection		Hiccup, automatics recovery
INPUT SPECIFICATIONS		
Input voltage range	12V nominal input	9 – 18VDC
	24V nominal input	18 – 36VDC
	48V nominal input	36 – 75VDC
Input filter		Pi type
Input surge voltage 100mS max	12V input	36VDC
	24V input	50VDC
	48V input	100VDC
Input reflected ripple (Note 3)	Nominal Vin and full load	40mA _{p-p}
Start up time	Nominal Vin and constant resistor load	25mS typ
Remote ON/OFF (Note 4)	DC-DC ON	Open or 3.5V < Vr < 12V
	DC-DC OFF	Short or 0V < Vr < 1.2V
	Remote off input current	Nominal input

GENERAL SPECIFICATIONS	
Efficiency	See table
Isolation voltage	1600VDC, min
Isolation resistance	10 ⁹ ohms, min
Isolation capacitance	500Pf, max
Switching frequency	185KHz, typ
Design meet safety standard	UL1950, EN60950
Case material	Nickel-coated copper
Base material	Non-conductive black FR4
Potting material	Epoxy (UL94-V0)
Dimensions	3.00 X 2.60 X 0.40 Inch (70.2 X 66.0 X 10.2 mm)
Weight	125g (4.4oz)
MTBF (Note 5)	1.590 x 10 ⁶ hrs

ENVIRONMENTAL SPECIFICATIONS	
Operating temperature range	-40°C ~ +85°C (with derating)
Maximum case temperature	+100°C
Storage temperature range	-55°C ~ +105°C
Thermal impedance Nature convection	5.7°C/watt
Thermal shock	MIL-STD-810D
Vibration	10~55Hz, 2G, 30minutes along X,Y and Z
Relative humidity	5% to 95% RH

EMC CHARACTERISTICS		
Conducted emissions	EN55022	Level A
Radiated emissions	EN55022	Level A
Conducted immunity	EN61000-4-6	Perf. Criteria2
Radiated immunity	EN61000-4-3	Perf. Criteria2
Surge	EN61000-4-5	Perf. Criteria2
Fast transient	EN61000-4-4	Perf. Criteria2
ESD	EN61000-4-2	Perf. Criteria2





Model Number	Input Range	Output Voltage	Output Current	Input Current ⁽⁶⁾	Eff ⁽⁷⁾ (%)	Capacitor ⁽⁸⁾ Load max
FDC40-12S33	9 – 18 VDC	3.3 VDC	1000mA	3530mA	83	25800uF
FDC40-12S05	9 – 18 VDC	5 VDC	8000mA	4170mA	84	13600uF
FDC40-12S12	9 – 18 VDC	12 VDC	3400mA	4100mA	87	2400uF
FDC40-12S15	9 – 18 VDC	15 VDC	2700mA	4100mA	87	1550uF
FDC40-12D05	9 – 18 VDC	± 5 VDC	+7000 / -1000mA	4330mA	81	12000 / 1700uF
FDC40-12D12	9 – 18 VDC	± 12 VDC	± 1800mA	4550mA	83	± 1200uF
FDC40-12D15	9 – 18 VDC	± 15 VDC	± 1400mA	4430mA	83	± 750uF
FDC40-12D3305	9 – 18 VDC	3.3 / 5VDC	4000 / 4000mA	3730mA	78	10300 / 6800uF
FDC40-12T0512	9 – 18 VDC	5 / ± 12 VDC	4000 / ± 850mA	4490mA	79	6800 / ± 590uF
FDC40-12T0515	9 – 18 VDC	5 / ± 15 VDC	4000 / ± 680mA	4430mA	80	6800 / ± 380uF
FDC40-24S33	18 – 36 VDC	3.3 VDC	10000mA	1720mA	84	25800uF
FDC40-24S05	18 – 36 VDC	5 VDC	8000mA	2010mA	87	13600uF
FDC40-24S12	18 – 36 VDC	12 VDC	3400mA	1980mA	90	2400uF
FDC40-24S15	18 – 36 VDC	15 VDC	2700mA	2000mA	88	1550uF
FDC40-24D05	18 – 36 VDC	± 5 VDC	+7000 / -1000mA	2130mA	82	12000 / 1700uF
FDC40-24D12	18 – 36 VDC	± 12 VDC	± 1800mA	2170mA	87	± 1200uF
FDC40-24D15	18 – 36 VDC	± 15 VDC	± 1400mA	2140mA	86	± 750uF
FDC40-24D3305	18 – 36 VDC	3.3 / 5VDC	4000 / 4000mA	1840mA	79	10300 / 6800uF
FDC40-24T0512	18 – 36 VDC	5 / ± 12 VDC	4000 / ± 850mA	2180mA	81	6800 / ± 590uF
FDC40-24T0515	18 – 36 VDC	5 / ± 15 VDC	4000 / ± 680mA	2160mA	82	6800 / ± 380uF
FDC40-48S33	36 – 75 VDC	3.3 VDC	10000mA	850mA	85	25800uF
FDC40-48S05	36 – 75 VDC	5 VDC	8000mA	980mA	89	13600uF
FDC40-48S12	36 – 75 VDC	12 VDC	3400mA	1000mA	89	2400uF
FDC40-48S15	36 – 75 VDC	15 VDC	2700mA	1000mA	88	1550uF
FDC40-48D05	36 – 75 VDC	± 5 VDC	+7000 / -1000mA	1060mA	84	12000 / 1700uF
FDC40-48D12	36 – 75 VDC	± 12 VDC	± 1800mA	1100mA	86	± 1200uF
FDC40-48D15	36 – 75 VDC	± 15 VDC	± 1400mA	1100mA	86	± 750uF
FDC40-48D3305	36 – 75 VDC	3.3 / 5VDC	4000 / 4000mA	910mA	80	10300 / 6800uF
FDC40-48T0512	36 – 75 VDC	5 / ± 12 VDC	4000 / ± 850mA	1060mA	83	6800 / ± 590uF
FDC40-48T0515	36 – 75 VDC	5 / ± 15 VDC	4000 / ± 680mA	1060mA	83	6800 / ± 380uF

Note

1. The FDC40 series required a minimum 10% loading on the output to maintain specified regulation. Operation under no-load condition will not damage these devices, however they may not meet all listed specification.
2. Cross regulation:
Dual output—Asymmetrical load 25% to 100% full load
Triple output – 3.3V / 5V 100% load and one of auxiliary 100% load, other auxiliary load change from 25% to 100% load
3. Simulated source impedance of 12uH. 12uH inductor in series with +Vin.
4. The ON-OFF control pin voltage is reference to negative input.
5. BELLCORE TR-NWT-000332. Case I: 50% Stress, Temperature at 40°C. (Ground fixed and controlled environment)
6. Maximum value at nominal input voltage and full load
7. Typical value at nominal input voltage and full load
8. Test by minimum Vin and constant resistor load.

FDC40-48S05
Efficiency VS Input Voltage

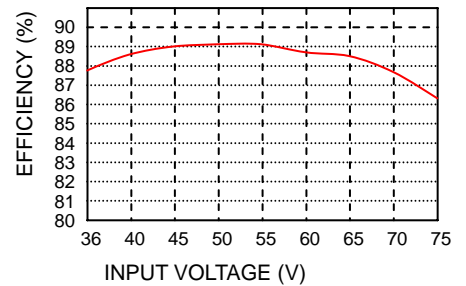

FDC40-48S05 Derating Curve

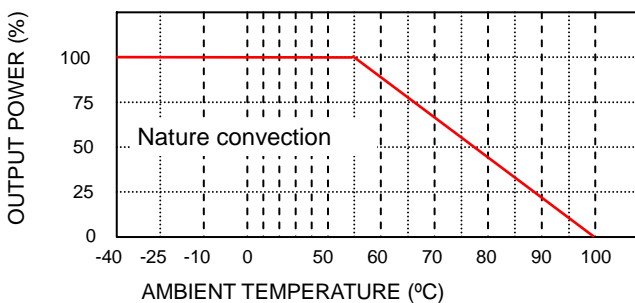

FDC40-48S05
Efficiency VS Output load

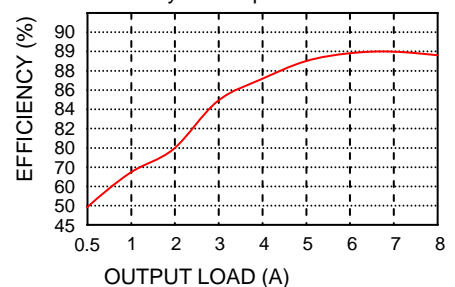

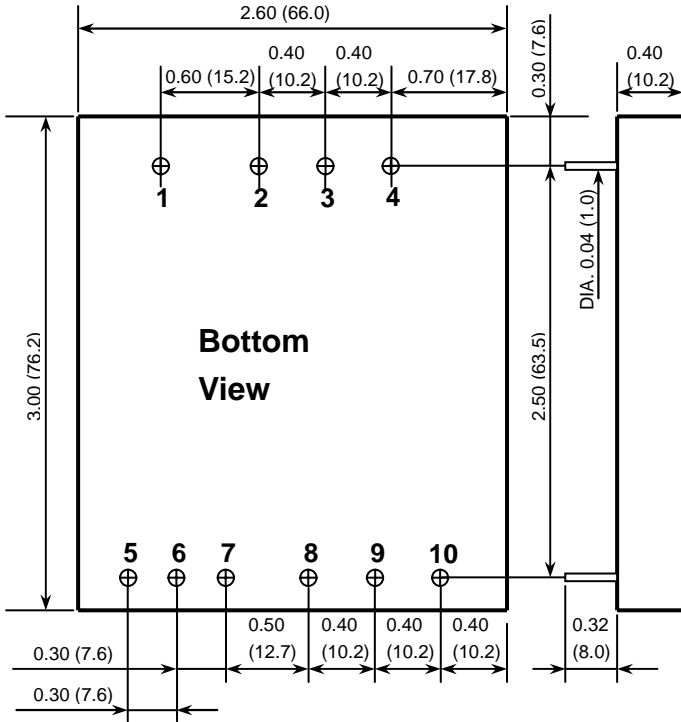

1. All dimensions in Inches (mm)
2. Pin pitch tolerance $\pm 0.014(0.35)$

EXTERNAL OUTPUT TRIMMING

Output can be externally trimmed by using the method shown below.
 () for dual output trim
 [] for triple output trim
 { } XXD3305 only trim 3.3V/5V

TRIM UP: 7 (7) [9] {6} \rightarrow R_U

TRIM DOWN: 6 (8) [10] {8} \rightarrow R_D

6 (8) [10] {8} \leftarrow R_U

5 (5) [8] {5} \leftarrow R_D

PIN CONNECTION				
PIN	SINGLE	DUAL	TRIPLE	3.3V / 5V
1	CTRL	CTRL	CTRL	CTRL
2	+ INPUT	+ INPUT	+ INPUT	+ INPUT
3	- INPUT	- INPUT	- INPUT	- INPUT
4	SYNC	SYNC	SYNC	SYNC
5	TRIM DOWN	+ OUTPUT	+ AUX	+3.3V
6	TRIM	COMMON	COMMON (AUX)	COMMON
7	TRIM UP	- OUTPUT	- AUX	+ 5V
8	+ OUTPUT	TRIM	+ OUTPUT(PRIMARY)	TRIM
9	- OUTPUT	NC	COMMON(PRIMARY)	NC
10	NO PIN	NC	TRIM	NC

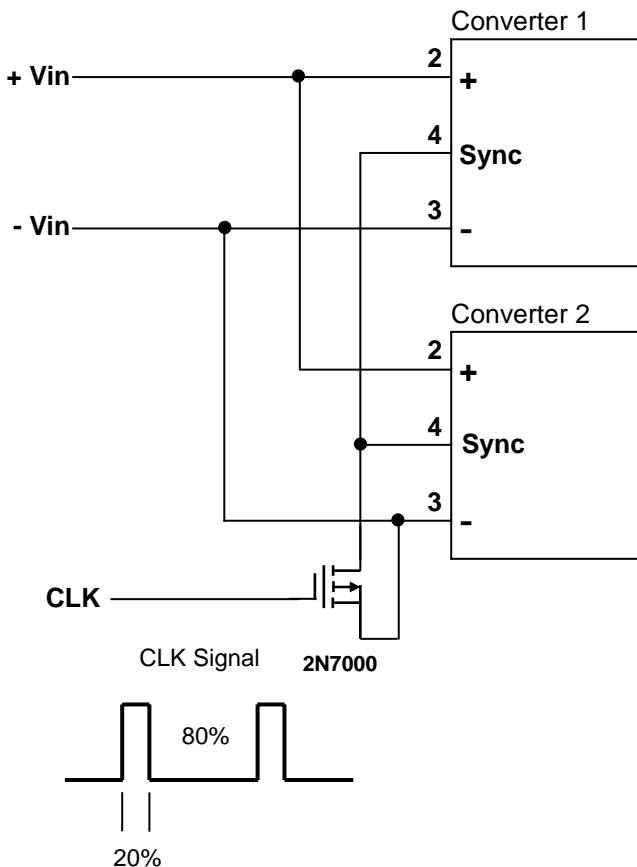

Application of synchronization

1. The unit is capable of external synchronization from an independent time base with a switching rate between 200kHz and 215kHz
2. The amplitude of the synchronizing pulse train is TTL compatible
3. The duty cycle of the CLK should be 20% high and 80% low
4. Synchronization is referenced to negative input (-Vin)

ON/OFF Control application

