

FLM1011-3F

X, Ku-Band Internally Matched FET

FEATURES

- High Output Power: $P_{1dB} = 35.0\text{dBm}$ (Typ.)
- High Gain: $G_{1dB} = 7.5\text{dB}$ (Typ.)
- High PAE: $\eta_{add} = 29\%$ (Typ.)
- Low $IM_3 = -46\text{dBc}@P_o = 24.0\text{dBm}$
- Broad Band: 10.7 ~ 11.7GHz
- Impedance Matched $Z_{in}/Z_{out} = 50\Omega$
- Hermetically Sealed

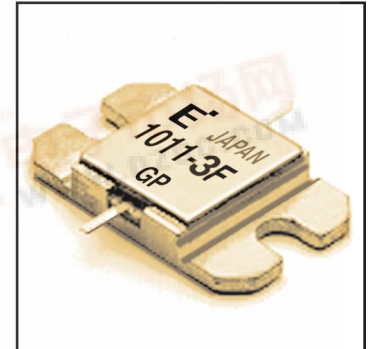

DESCRIPTION

The FLM1011-3F is a power GaAs FET that is internally matched for standard communication bands to provide optimum power and gain in a 50 ohm system.

Eudyna's stringent Quality Assurance Program assures the highest reliability and consistent performance.

ABSOLUTE MAXIMUM RATING (Ambient Temperature $T_a=25^\circ\text{C}$)

Item	Symbol	Condition	Rating	Unit
Drain-Source Voltage	V_{DS}		15	V
Gate-Source Voltage	V_{GS}		-5	V
Total Power Dissipation	P_T	$T_C = 25^\circ\text{C}$	25.0	W
Storage Temperature	T_{stg}		-65 to +175	$^\circ\text{C}$
Channel Temperature	T_{ch}		175	$^\circ\text{C}$

Fujitsu recommends the following conditions for the reliable operation of GaAs FETs:

1. The drain-source operating voltage (V_{DS}) should not exceed 10 volts.
2. The forward and reverse gate currents should not exceed 13.0 and -1.4 mA respectively with gate resistance of 100 Ω .

ELECTRICAL CHARACTERISTICS (Ambient Temperature $T_a=25^\circ\text{C}$)

Item	Symbol	Test Conditions	Limit			Unit
			Min.	Typ.	Max.	
Saturated Drain Current	I_{DSS}	$V_{DS} = 5\text{V}, V_{GS} = 0\text{V}$	-	1400	2100	mA
Transconductance	g_m	$V_{DS} = 5\text{V}, I_{DS} = 900\text{mA}$	-	1300	-	mS
Pinch-off Voltage	V_p	$V_{DS} = 5\text{V}, I_{DS} = 70\text{mA}$	-0.5	-1.5	-3.0	V
Gate Source Breakdown Voltage	V_{GSO}	$I_{GS} = -70\mu\text{A}$	-5.0	-	-	V
Output Power at 1dB G.C.P.	P_{1dB}		34.0	35.0	-	dBm
Power Gain at 1dB G.C.P.	G_{1dB}	$V_{DS} = 10\text{V},$ $I_{DS} = 0.6 I_{DSS}(\text{Typ.}),$ $f = 10.7 \sim 11.7 \text{GHz},$ $Z_S = Z_L = 50\Omega$	6.5	7.5	-	dB
Drain Current	I_{dsr}		-	900	1100	mA
Power-Added Efficiency	η_{add}		-	29	-	%
Gain Flatness	ΔG		-	-	± 0.6	dB
3rd Order Intermodulation Distortion	IM_3	$f = 11.7\text{GHz}, \Delta f = 10\text{MHz}$ 2-Tone Test $P_{out} = 24.0\text{dBm S.C.L.}$	-44	-46	-	dBc
Thermal Resistance	R_{th}	Channel to Case	-	5.0	6.0	$^\circ\text{C}/\text{W}$
Channel Temperature Rise	ΔT_{ch}	$10\text{V} \times I_{dsr} \times R_{th}$	-	-	66	$^\circ\text{C}$

CASE STYLE: IA

G.C.P.: Gain Compression Point, S.C.L.: Single Carrier Level



FLM1011-3F

X, Ku-Band Internally Matched FET

POWER DERATING CURVE

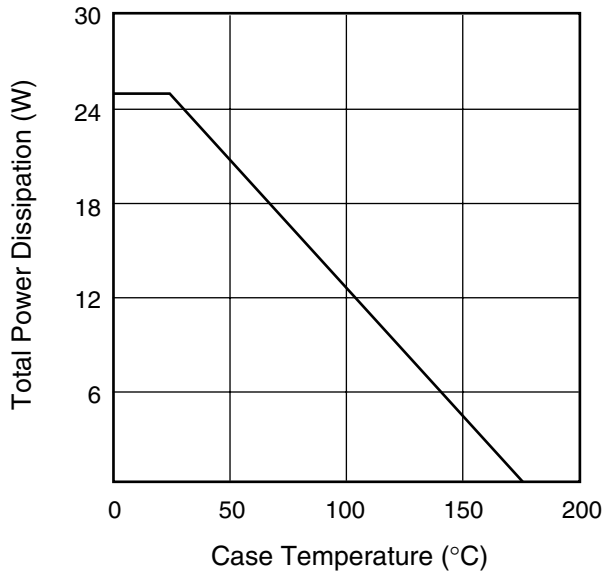

OUTPUT POWER & IM₃ vs. INPUT POWER

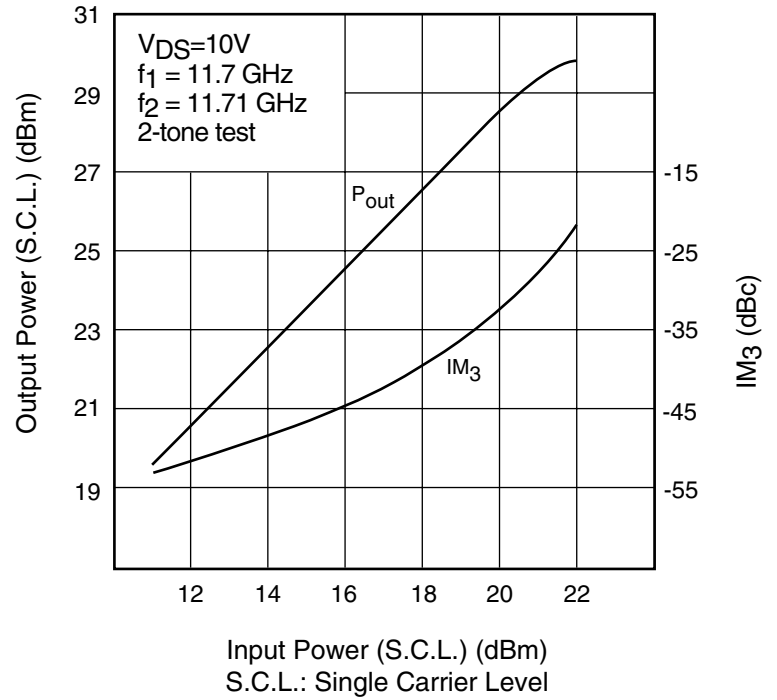

OUTPUT POWER vs. FREQUENCY

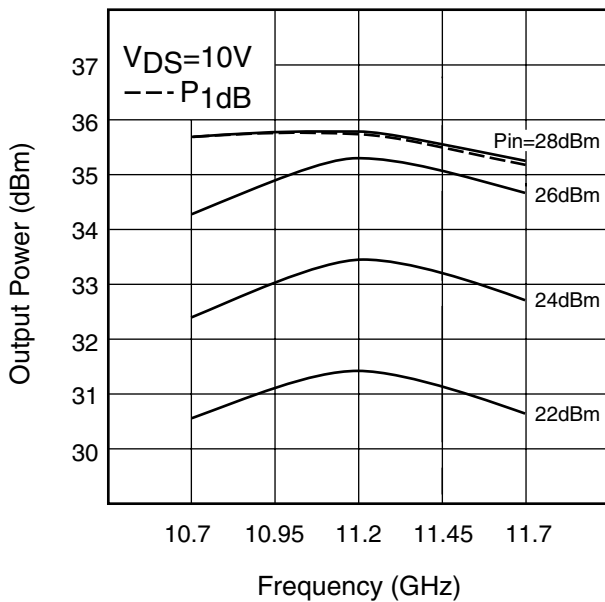

OUTPUT POWER vs. INPUT POWER

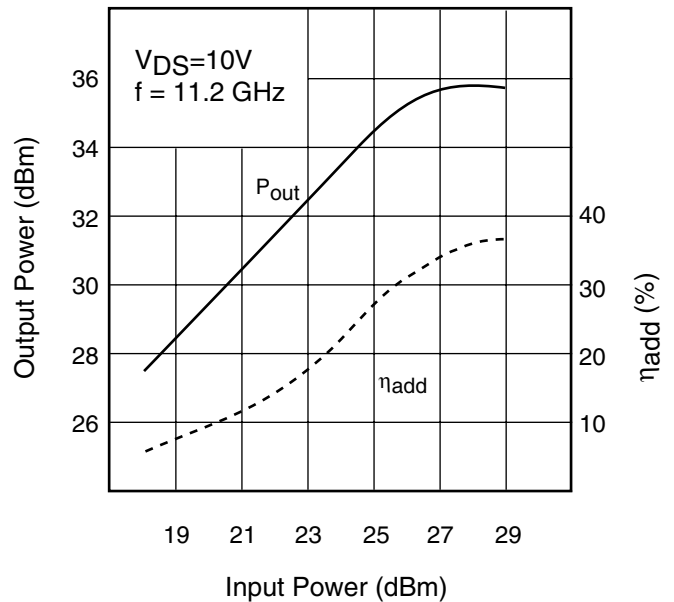

FLM1011-3F

X, Ku-Band Internally Matched FET

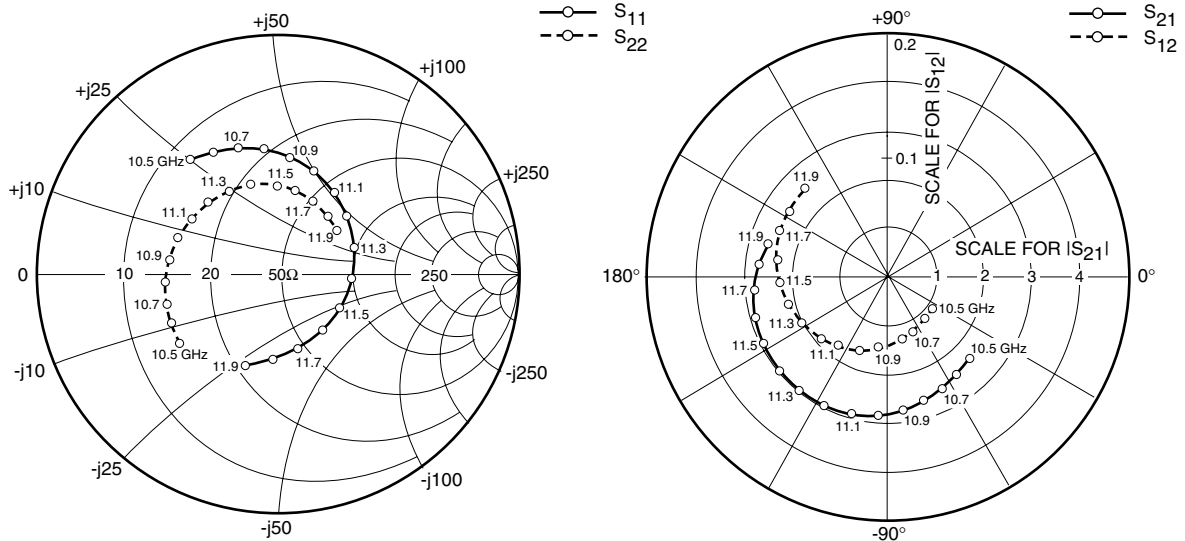

S-PARAMETERS

$V_{DS} = 10V, I_{DS} = 900mA$

FREQUENCY (MHZ)	S11		S21		S12		S22	
	MAG	ANG	MAG	ANG	MAG	ANG	MAG	ANG
10500	.606	127.5	2.381	-45.7	.045	-34.6	.500	-144.6
10600	.586	118.0	2.475	-54.3	.047	-47.4	.491	-154.2
10700	.556	107.5	2.574	-63.8	.050	-64.6	.474	-165.0
10800	.532	96.4	2.663	-73.4	.053	-76.4	.466	-175.9
10900	.493	84.3	2.767	-83.3	.058	-98.2	.452	172.4
11000	.457	71.3	2.859	-94.1	.064	-110.4	.442	159.8
11100	.413	55.9	2.929	-105.0	.070	-126.2	.430	146.9
11200	.375	38.7	2.984	-116.4	.075	-137.1	.424	133.6
11300	.333	19.7	2.995	-127.8	.081	-151.9	.411	120.4
11400	.301	-3.4	2.992	-139.6	.086	-164.5	.394	106.6
11500	.291	-28.4	2.935	-151.4	.089	-177.0	.375	92.5
11600	.297	-51.8	2.861	-162.7	.093	171.1	.361	79.1
11700	.320	-74.6	2.776	-173.8	.096	157.2	.341	65.6
11800	.354	-93.8	2.681	175.3	.097	147.3	.320	50.6
11900	.399	-109.4	2.565	164.8	.099	134.2	.305	37.7

FLM1011-3F

X, Ku-Band Internally Matched FET

Case Style "IA" Metal-Ceramic Hermetic Package

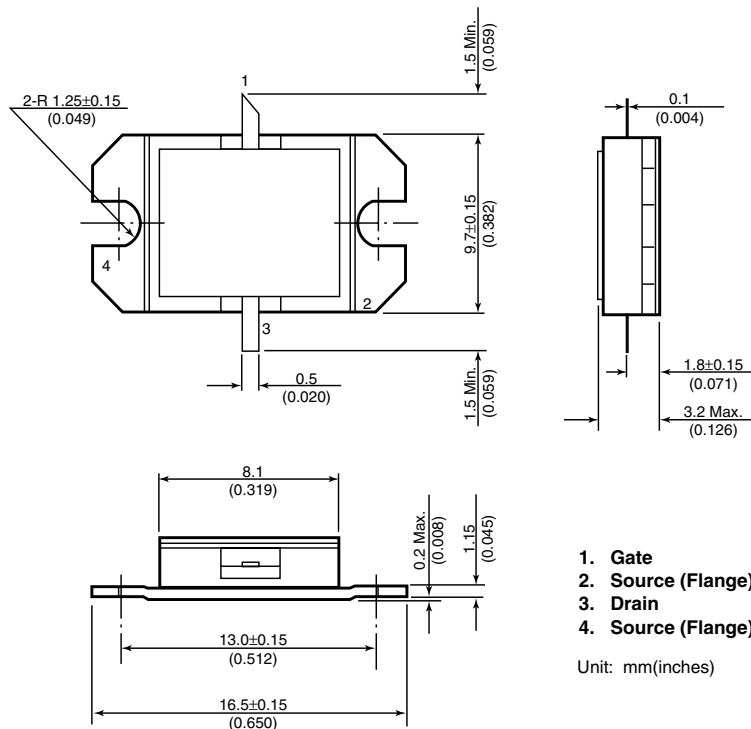

For further information please contact:

Eudyna Devices USA Inc.

2355 Zanker Rd.
San Jose, CA 95131-1138, U.S.A.
TEL: (408) 232-9500
FAX: (408) 428-9111
www.us.eudyna.com

Eudyna Devices Europe Ltd.

Network House
Norreys Drive
Maidenhead, Berkshire SL6 4FJ
United Kingdom
TEL: +44 (0) 1628 504800
FAX: +44 (0) 1628 504888

Eudyna Devices Asia Pte Ltd.

Hong Kong Branch
Rm. 1101, Ocean Centre, 5 Canton Rd.
Tsim Sha Tsui, Kowloon, Hong Kong
TEL: +852-2377-0227
FAX: +852-2377-3921

Eudyna Devices Inc.

Sales Division
1, Kanai-cho, Sakae-ku
Yokohama, 244-0845, Japan
TEL: +81-45-853-8156
FAX: +81-45-853-8170

CAUTION

Eudyna Devices Inc. products contain **gallium arsenide (GaAs)** which can be hazardous to the human body and the environment. For safety, observe the following procedures:

- Do not put this product into the mouth.
- Do not alter the form of this product into a gas, powder, or liquid through burning, crushing, or chemical processing as these by-products are dangerous to the human body if inhaled, ingested, or swallowed.
- Observe government laws and company regulations when discarding this product. This product must be discarded in accordance with methods specified by applicable hazardous waste procedures.

Eudyna Devices Inc. reserves the right to change products and specifications without notice. The information does not convey any license under rights of Eudyna Devices Inc. or others.

© 2004 Eudyna Devices USA Inc.
Printed in U.S.A.