

FLM1011-6F

X, Ku-Band Internally Matched FET

FEATURES

- High Output Power: $P_{1dB} = 37.5\text{dBm}$ (Typ.)
- High Gain: $G_{1dB} = 7.5\text{dB}$ (Typ.)
- High PAE: $\eta_{add} = 28\%$ (Typ.)
- Low $IM_3 = -45\text{dBc}$ @ $P_o = 25\text{dBm}$
- Broad Band: 10.7 ~ 11.7GHz
- Impedance Matched $Z_{in}/Z_{out} = 50\Omega$
- Hermetically Sealed

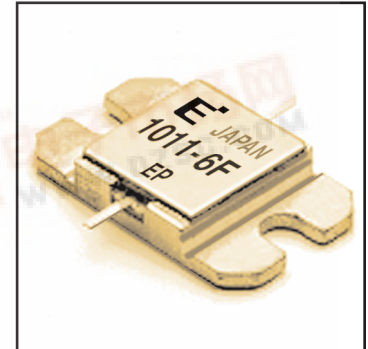

DESCRIPTION

The FLM1011-6F is a power GaAs FET that is internally matched for standard communication bands to provide optimum power and gain in a 50 ohm system.

Eudyna's stringent Quality Assurance Program assures the highest reliability and consistent performance.

ABSOLUTE MAXIMUM RATING (Ambient Temperature $T_a=25^\circ\text{C}$)

Item	Symbol	Condition	Rating	Unit
Drain-Source Voltage	V_{DS}		15	V
Gate-Source Voltage	V_{GS}		-5	V
Total Power Dissipation	P_T	$T_C = 25^\circ\text{C}$	31.2	W
Storage Temperature	T_{stg}		-65 to +175	$^\circ\text{C}$
Channel Temperature	T_{ch}		175	$^\circ\text{C}$

Fujitsu recommends the following conditions for the reliable operation of GaAs FETs:

1. The drain-source operating voltage (V_{DS}) should not exceed 10 volts.
2. The forward and reverse gate currents should not exceed 26.0 and -2.8 mA respectively with gate resistance of 100 Ω .

ELECTRICAL CHARACTERISTICS (Ambient Temperature $T_a=25^\circ\text{C}$)

Item	Symbol	Test Conditions	Limit			Unit
			Min.	Typ.	Max.	
Saturated Drain Current	I_{DSS}	$V_{DS} = 5\text{V}, V_{GS} = 0\text{V}$	-	2800	4200	mA
Transconductance	g_m	$V_{DS} = 5\text{V}, I_{DS} = 1800\text{mA}$	-	2350	-	mS
Pinch-off Voltage	V_p	$V_{DS} = 5\text{V}, I_{DS} = 120\text{mA}$	-0.5	-1.5	-3.0	V
Gate Source Breakdown Voltage	V_{GSO}	$I_{GS} = -120\mu\text{A}$	-5	-	-	V
Output Power at 1dB G.C.P.	P_{1dB}	$V_{DS} = 10\text{V},$ $I_{DS} = 0.6 I_{DSS}(\text{Typ.}),$ $f = 10.7 \sim 11.7 \text{GHz},$ $Z_S = Z_L = 50\Omega$	36.5	37.5	-	dBm
Power Gain at 1dB G.C.P.	G_{1dB}		6.5	7.5	-	dB
Drain Current	I_{dsr}		-	1800	2100	mA
Power-Added Efficiency	η_{add}		-	28	-	%
Gain Flatness	ΔG		-	-	± 0.6	dB
3rd Order Intermodulation Distortion	IM_3	$f = 11.7\text{GHz}, \Delta f = 10\text{MHz}$ 2-Tone Test $P_{out} = 25\text{dBm S.C.L.}$	-42	-45	-	dBc
Thermal Resistance	R_{th}	Channel to Case	-	4.0	4.5	$^\circ\text{C/W}$

PACKAGE STYLE: IA

G.C.P.: Gain Compression Point, S.C.L.: Single Carrier Level



FLM1011-6F

X, Ku-Band Internally Matched FET

POWER DERATING CURVE

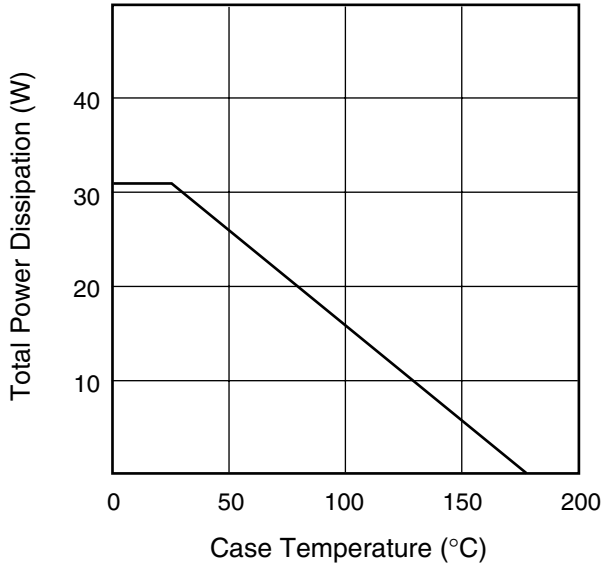

OUTPUT POWER & IM₃ vs. INPUT POWER

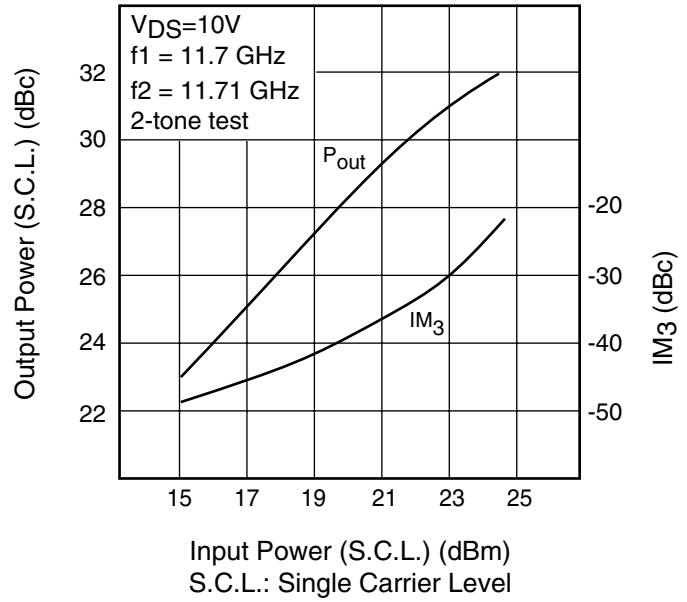

OUTPUT POWER vs. FREQUENCY

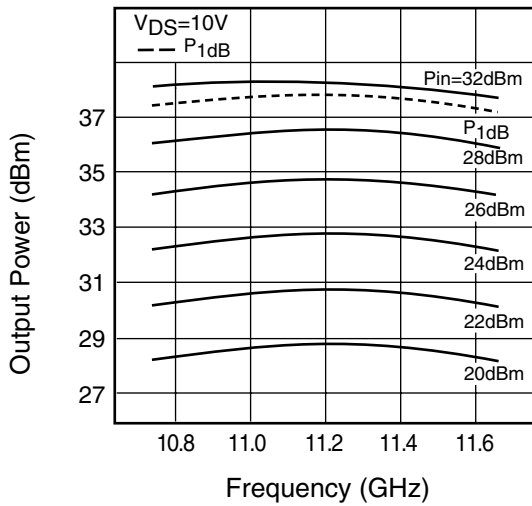

OUTPUT POWER vs. INPUT POWER

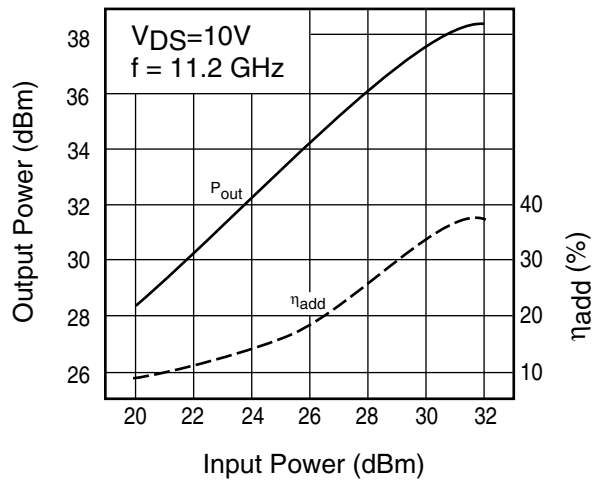

FLM1011-6F

X, Ku-Band Internally Matched FET

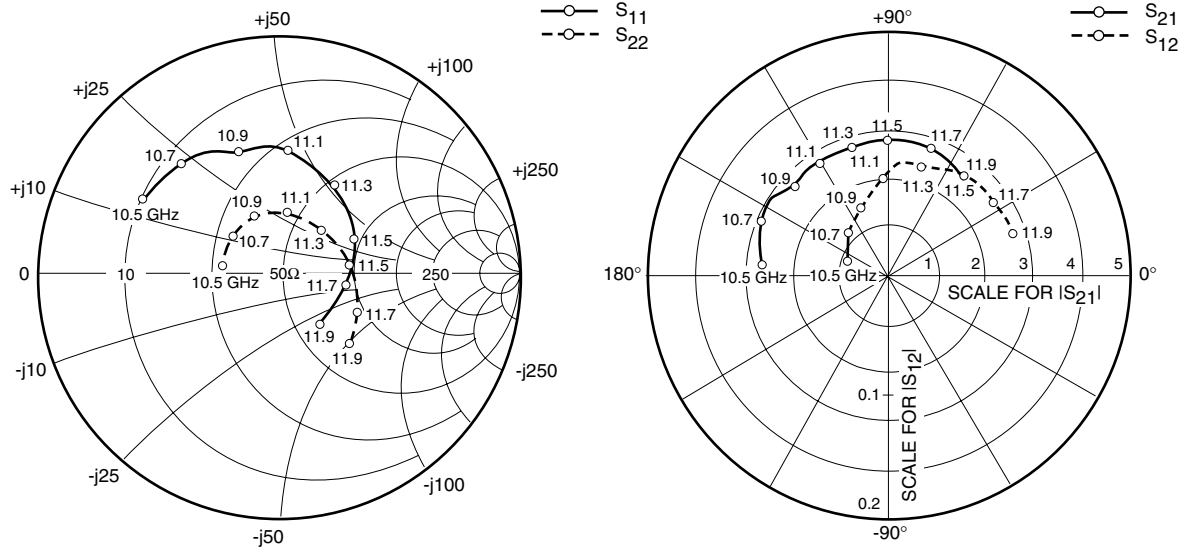

S-PARAMETERS

$V_{DS} = 10V, I_{DS} = 1800mA$

FREQUENCY (MHZ)	S11		S21		S12		S22	
	MAG	ANG	MAG	ANG	MAG	ANG	MAG	ANG
10500	.655	149.3	2.654	175.1	.037	160.5	.230	168.6
10600	.639	139.8	2.766	167.0	.039	151.3	.245	151.6
10700	.621	130.3	2.896	157.7	.049	135.2	.264	136.9
10800	.601	120.5	2.899	146.9	.050	127.2	.270	123.0
10900	.580	109.7	2.855	137.6	.060	113.5	.293	111.3
11000	.555	98.4	2.760	128.8	.066	104.6	.284	96.4
11100	.523	85.9	2.685	121.5	.078	93.9	.290	83.8
11200	.488	72.6	2.683	114.7	.086	83.3	.281	67.2
11300	.443	58.8	2.693	107.1	.091	74.1	.282	49.6
11400	.397	42.8	2.736	99.3	.097	62.7	.286	29.7
11500	.350	27.2	2.740	90.6	.099	53.0	.302	11.4
11600	.311	9.3	2.785	82.0	.103	41.7	.315	-5.8
11700	.282	-9.1	2.780	70.9	.103	35.4	.348	-22.4
11800	.259	-30.2	2.663	58.7	.108	25.6	.372	-36.8
11900	.252	-51.0	2.469	49.1	.107	18.6	.396	-48.2

FLM1011-6F

X, Ku-Band Internally Matched FET

Case Style "IA"

Metal-Ceramic Hermetic Package

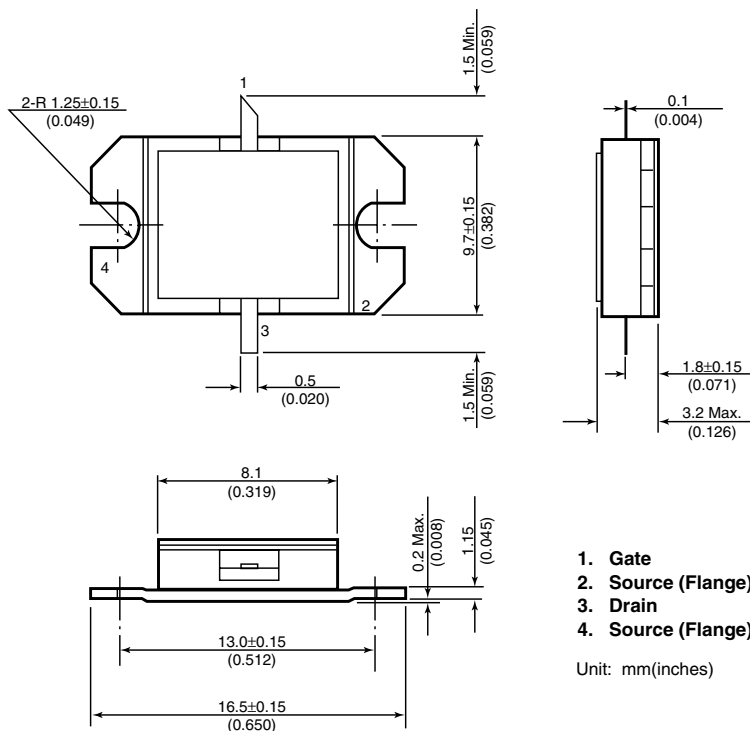

For further information please contact:

Eudyna Devices USA Inc.

2355 Zanker Rd.
San Jose, CA 95131-1138, U.S.A.
TEL: (408) 232-9500
FAX: (408) 428-9111
www.us.eudyna.com

Eudyna Devices Europe Ltd.

Network House
Norreys Drive
Maidenhead, Berkshire SL6 4FJ
United Kingdom
TEL: +44 (0) 1628 504800
FAX: +44 (0) 1628 504888

Eudyna Devices Asia Pte Ltd.

Hong Kong Branch
Rm. 1101, Ocean Centre, 5 Canton Rd.
Tsim Sha Tsui, Kowloon, Hong Kong
TEL: +852-2377-0227
FAX: +852-2377-3921

Eudyna Devices Inc.

Sales Division
1, Kanai-cho, Sakae-ku
Yokohama, 244-0845, Japan
TEL: +81-45-853-8156
FAX: +81-45-853-8170

CAUTION

Eudyna Devices Inc. products contain **gallium arsenide (GaAs)** which can be hazardous to the human body and the environment. For safety, observe the following procedures:

- Do not put this product into the mouth.
- Do not alter the form of this product into a gas, powder, or liquid through burning, crushing, or chemical processing as these by-products are dangerous to the human body if inhaled, ingested, or swallowed.
- Observe government laws and company regulations when discarding this product. This product must be discarded in accordance with methods specified by applicable hazardous waste procedures.

Eudyna Devices Inc. reserves the right to change products and specifications without notice. The information does not convey any license under rights of Eudyna Devices Inc. or others.

© 2004 Eudyna Devices USA Inc.
Printed in U.S.A.