

FLM1213-12F

X, Ku-Band Internally Matched FET

FEATURES

- High Output Power: $P_{1dB} = 40.5dBm$ (Typ.)
- High Gain: $G_{1dB} = 5.5dB$ (Typ.)
- High PAE: $\eta_{add} = 24%$ (Typ.)
- $IM_3 = -45dBc @ P_o = 28dBm$
- Broad Band: 12.7 ~ 13.2GHz
- Impedance Matched $Z_{in}/Z_{out} = 50\Omega$
- Hermetically Sealed

DESCRIPTION

The FLM1213-12F is a power GaAs FET that is internally matched for standard communication bands to provide optimum power and gain in a 50 ohm system.

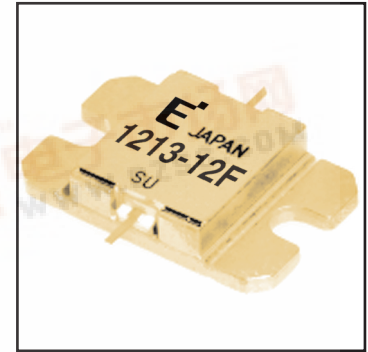

Eudyna's stringent Quality Assurance Program assures the highest reliability and consistent performance.

ABSOLUTE MAXIMUM RATING (Ambient Temperature $T_a=25^\circ C$)

Item	Symbol	Condition	Rating	Unit
Drain-Source Voltage	V_{DS}		15	V
Gate-Source Voltage	V_{GS}		-5	V
Total Power Dissipation	P_T	$T_C = 25^\circ C$	57.6	W
Storage Temperature	T_{stg}		-65 to +175	$^\circ C$
Channel Temperature	T_{ch}		175	$^\circ C$

Fujitsu recommends the following conditions for the reliable operation of GaAs FETs:

1. The drain-source operating voltage (V_{DS}) should not exceed 10 volts.
2. The forward and reverse gate currents should not exceed 34.0 and -5.0 mA respectively with gate resistance of 50 Ω .

ELECTRICAL CHARACTERISTICS (Ambient Temperature $T_a=25^\circ C$)

Item	Symbol	Test Conditions	Limit			Unit
			Min.	Typ.	Max.	
Saturated Drain Current	I_{DSS}	$V_{DS} = 5V, V_{GS} = 0V$	-	6000	9000	mA
Transconductance	g_m	$V_{DS} = 5V, I_{DS} = 3600mA$	-	5000	-	mS
Pinch-off Voltage	V_p	$V_{DS} = 5V, I_{DS} = 300mA$	-0.5	-1.5	-3.0	V
Gate Source Breakdown Voltage	V_{GSO}	$I_{GS} = -340\mu A$	-5	-	-	V
Output Power at 1dB G.C.P.	P_{1dB}	$V_{DS} = 10V$ $f = 12.7 \sim 13.2 GHz$ $I_{DS} = 0.6 I_{DSS}(Typ.)$ $Z_S = Z_L = 50\Omega$	39.5	40.5	-	dBm
Power Gain at 1dB G.C.P.	G_{1dB}		4.5	5.5	-	dB
Drain Current	I_{dsr}		-	3600	4500	mA
Power-Added Efficiency	η_{add}		-	24	-	%
Gain Flatness	ΔG		-	-	± 0.6	dB
3rd Order Intermodulation Distortion	IM_3	$f = 13.2GHz, \Delta f = 10MHz$ 2-Tone Test $P_{out} = 28dBm S.C.L.$	-42	-45	-	dBc
Thermal Resistance	R_{th}	Channel to Case	-	2.3	2.6	$^\circ C/W$
Channel Temperature Rise	ΔT_{ch}	$10V \times I_{dsr} \times R_{th}$	-	-	80	$^\circ C$

CASE STYLE: IB

G.C.P.: Gain Compression Point

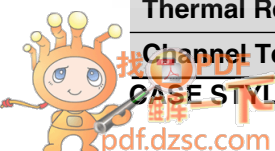

FLM1213-12F

X, Ku-Band Internally Matched FET

POWER DERATING CURVE

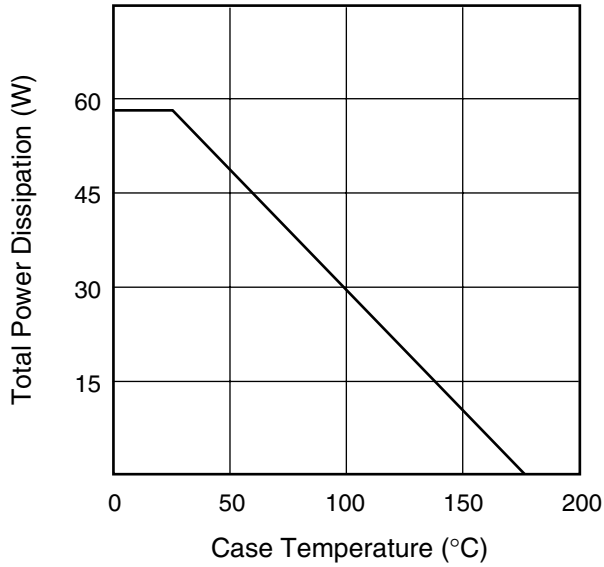

OUTPUT POWER & IM₃ vs. INPUT POWER

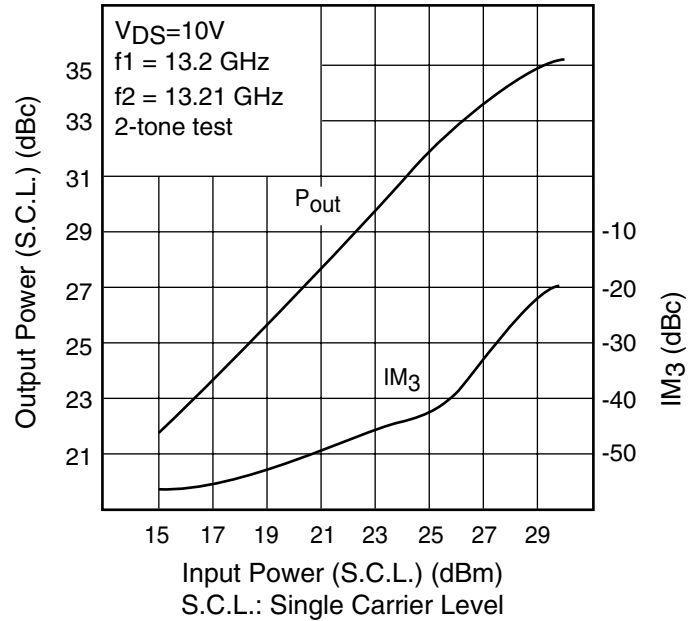

OUTPUT POWER vs. FREQUENCY

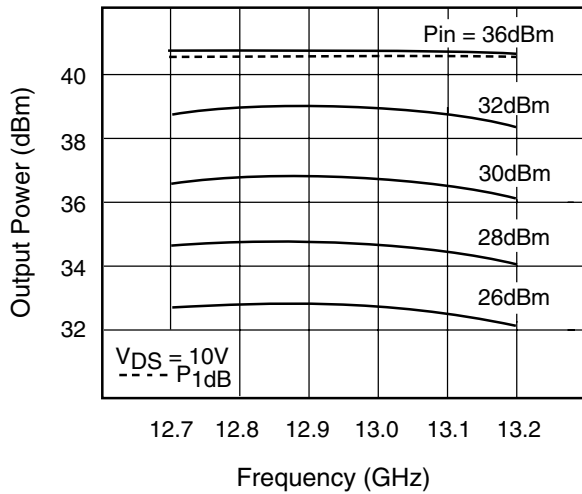

OUTPUT POWER vs. INPUT POWER

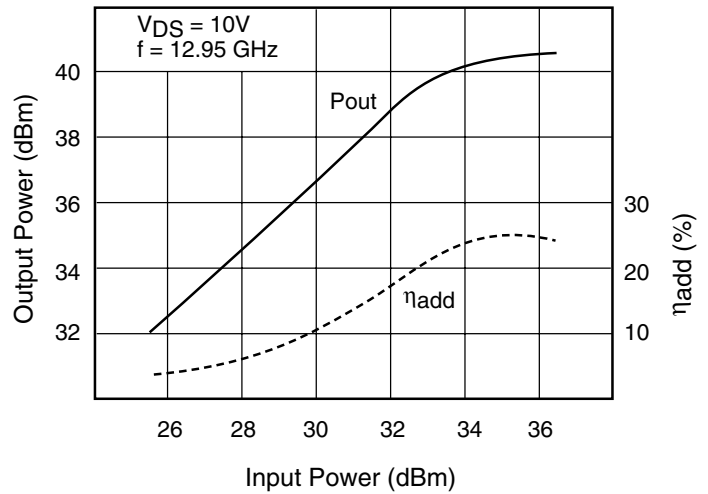

FLM1213-12F

X, Ku-Band Internally Matched FET

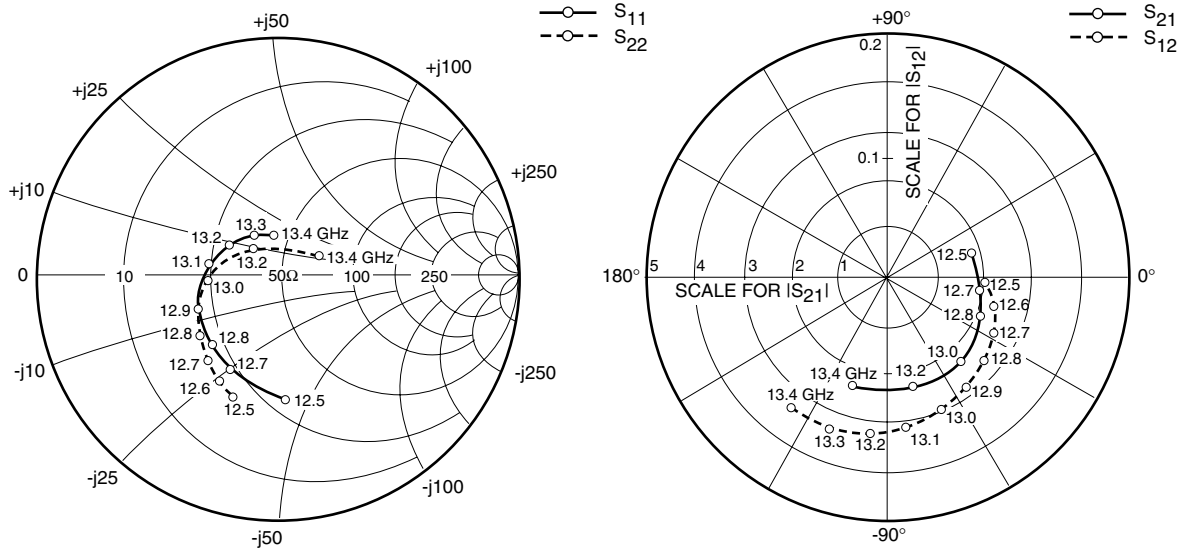

S-PARAMETERS

$V_{DS} = 10V, I_{DS} = 3600mA$

FREQUENCY (MHZ)	S11		S21		S12		S22	
	MAG	ANG	MAG	ANG	MAG	ANG	MAG	ANG
12500	.511	-86.9	1.787	16.5	.080	-2.7	.531	-110.8
12600	.474	-101.9	1.891	4.5	.089	-15.2	.497	-121.6
12700	.435	-118.0	1.995	-8.2	.098	-27.4	.460	-132.6
12800	.400	-134.6	2.092	-21.1	.104	-40.6	.414	-144.1
12900	.360	-152.2	2.192	-34.1	.112	-54.4	.362	-158.1
13000	.324	-171.0	2.283	-47.9	.120	-68.6	.298	-175.0
13100	.290	168.5	2.341	-62.2	.127	-82.8	.229	164.7
13200	.249	147.6	2.386	-77.2	.132	-97.1	.164	133.3
13300	.212	125.2	2.369	-91.4	.136	-111.6	.127	82.9
13400	.172	100.6	2.343	-106.4	.134	-126.6	.169	34.4

FLM1213-12F

X, Ku-Band Internally Matched FET

Case Style "IB" Metal-Ceramic Hermetic Package

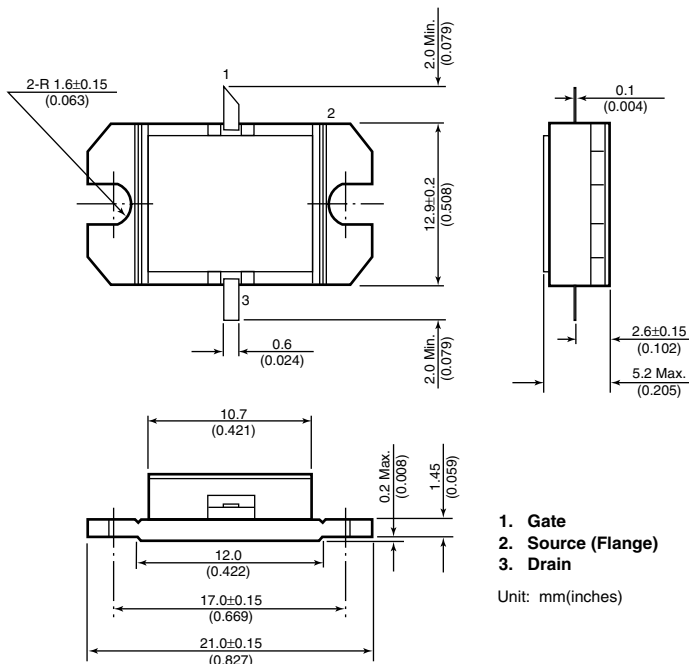

For further information please contact:

Eudyna Devices USA Inc.

2355 Zanker Rd.
San Jose, CA 95131-1138, U.S.A.
TEL: (408) 232-9500
FAX: (408) 428-9111
www.us.eudyna.com

Eudyna Devices Europe Ltd.

Network House
Norreys Drive
Maidenhead, Berkshire SL6 4FJ
United Kingdom
TEL: +44 (0) 1628 504800
FAX: +44 (0) 1628 504888

Eudyna Devices Asia Pte Ltd.

Hong Kong Branch
Rm. 1101, Ocean Centre, 5 Canton Rd.
Tsim Sha Tsui, Kowloon, Hong Kong
TEL: +852-2377-0227
FAX: +852-2377-3921

Eudyna Devices Inc.

Sales Division
1, Kanai-cho, Sakae-ku
Yokohama, 244-0845, Japan
TEL: +81-45-853-8156
FAX: +81-45-853-8170

CAUTION

Eudyna Devices Inc. products contain **gallium arsenide (GaAs)** which can be hazardous to the human body and the environment. For safety, observe the following procedures:

- Do not put this product into the mouth.
- Do not alter the form of this product into a gas, powder, or liquid through burning, crushing, or chemical processing as these by-products are dangerous to the human body if inhaled, ingested, or swallowed.
- Observe government laws and company regulations when discarding this product. This product must be discarded in accordance with methods specified by applicable hazardous waste procedures.

Eudyna Devices Inc. reserves the right to change products and specifications without notice. The information does not convey any license under rights of Eudyna Devices Inc. or others.

© 2004 Eudyna Devices USA Inc.
Printed in U.S.A.