

FEATURES

- High Output Power: $P_{1dB} = 35.0\text{dBm}$ (Typ.)
- High Gain: $G_{1dB} = 5.5\text{dB}$ (Typ.)
- High PAE: $\eta_{add} = 25\%$ (Typ.)
- Low $IM_3 = -45\text{dBc}$ @ $P_o = 24.0\text{dBm}$
- Broad Band: 13.75 ~ 14.5GHz
- Impedance Matched $Z_{in}/Z_{out} = 50\Omega$

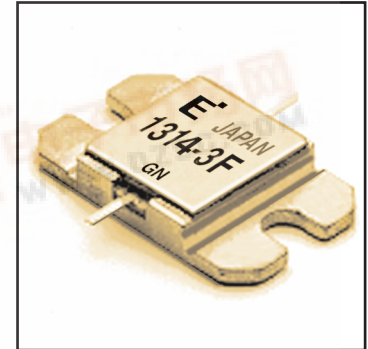

DESCRIPTION

The FLM1314-3F is a power GaAs FET that is internally matched for standard communication bands to provide optimum power and gain in a 50 ohm system.

Eudyna's stringent Quality Assurance Program assures the highest reliability and consistent performance.

ABSOLUTE MAXIMUM RATING (Ambient Temperature $T_a=25^\circ\text{C}$)

Item	Symbol	Condition	Rating	Unit
Drain-Source Voltage	V_{DS}		15	V
Gate-Source Voltage	V_{GS}		-5	V
Total Power Dissipation	P_T	$T_C = 25^\circ\text{C}$	25.0	W
Storage Temperature	T_{stg}		-65 to +175	$^\circ\text{C}$
Channel Temperature	T_{ch}		175	$^\circ\text{C}$

Fujitsu recommends the following conditions for the reliable operation of GaAs FETs:

1. The drain-source operating voltage (V_{DS}) should not exceed 10 volts.
2. The forward and reverse gate currents should not exceed 13.0 and -1.4 mA respectively with gate resistance of 100 Ω .

ELECTRICAL CHARACTERISTICS (Ambient Temperature $T_a=25^\circ\text{C}$)

Item	Symbol	Test Conditions	Limit			Unit
			Min.	Typ.	Max.	
Saturated Drain Current	I_{DSS}	$V_{DS} = 5\text{V}, V_{GS} = 0\text{V}$	-	1400	2100	mA
Transconductance	g_m	$V_{DS} = 5\text{V}, I_{DS} = 900\text{mA}$	-	1300	-	mS
Pinch-off Voltage	V_p	$V_{DS} = 5\text{V}, I_{DS} = 70\text{mA}$	-0.5	-1.5	-3.0	V
Gate Source Breakdown Voltage	V_{GSO}	$I_{GS} = -70\mu\text{A}$	-5.0	-	-	V
Output Power at 1dB G.C.P.	P_{1dB}	$V_{DS} = 10\text{V},$ $I_{DS} = 0.6 I_{DSS}$ (Typ.), $f = 13.75 \sim 14.5 \text{GHz},$ $Z_S = Z_L = 50 \text{ohm}$	34.0	35.0	-	dBm
Power Gain at 1dB G.C.P.	G_{1dB}		5.0	5.5	-	dB
Drain Current	I_{dsr}		-	900	1100	mA
Power-added Efficiency	η_{add}		-	25	-	%
Gain Flatness	ΔG		-	-	± 0.6	dB
3rd Order Intermodulation Distortion	IM_3	$f = 14.5\text{GHz}, \Delta f = 10 \text{MHz}$ 2-Tone Test $P_{out} = 24.0\text{dBm S.C.L.}$	-42	-45	-	dBc
Thermal Resistance	R_{th}	Channel to Case	-	5.0	6.0	$^\circ\text{C/W}$
Channel Temperature Rise	ΔT_{ch}	$10\text{V} \times I_{dsr} \times R_{th}$	-	-	66	$^\circ\text{C}$

G.C.P.: Gain Compression Point, S.C.L.: Single Carrier Level

FLM1314-3F

X, Ku-Band Internally Matched FET

POWER DERATING CURVE

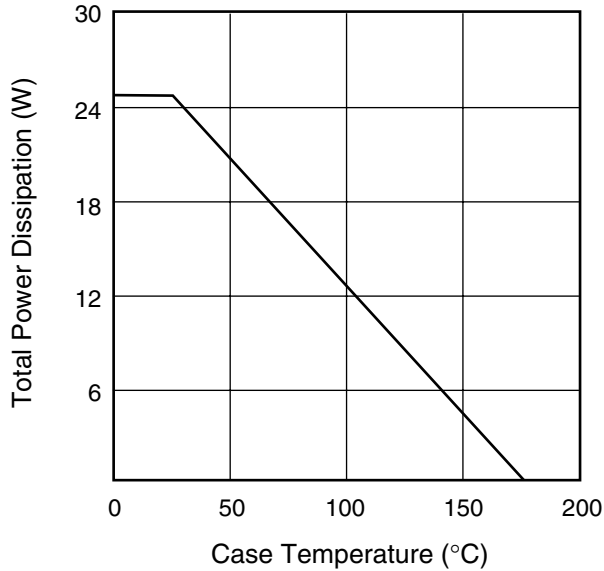

OUTPUT POWER & IM₃ vs. INPUT POWER

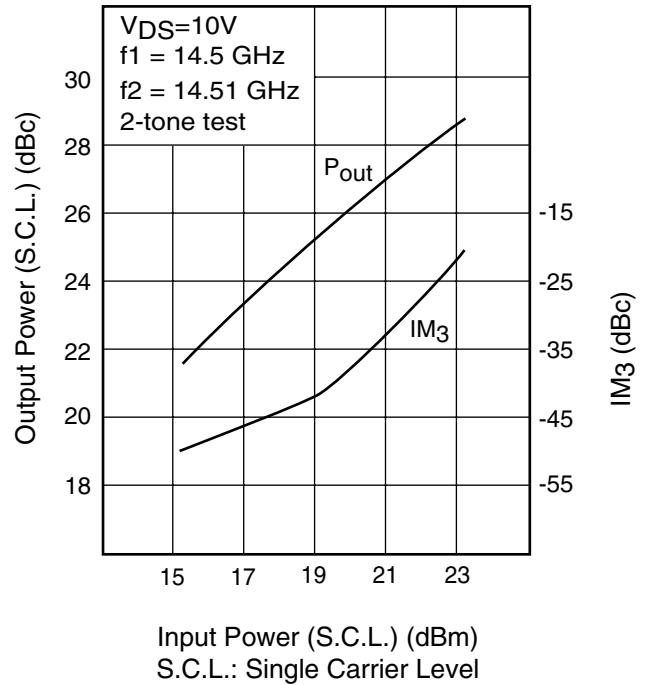

OUTPUT POWER vs. FREQUENCY

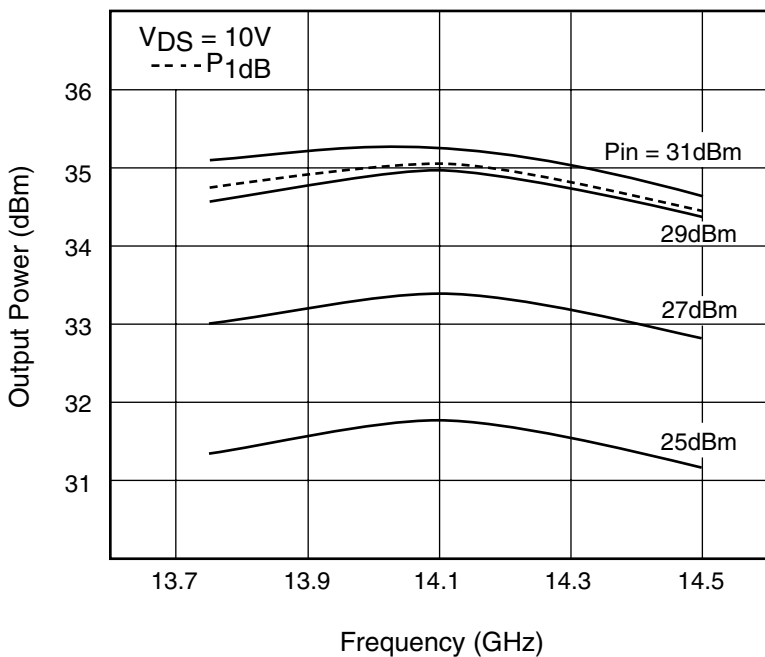

OUTPUT POWER vs. INPUT POWER

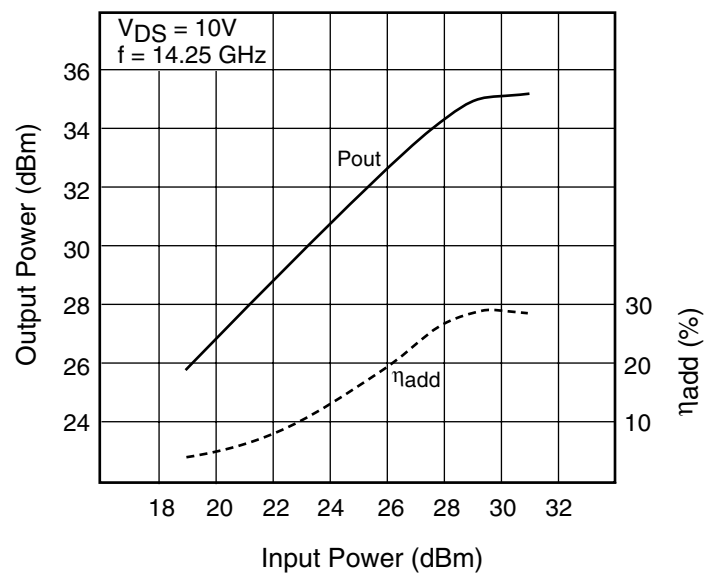

FLM1314-3F

X, Ku-Band Internally Matched FET

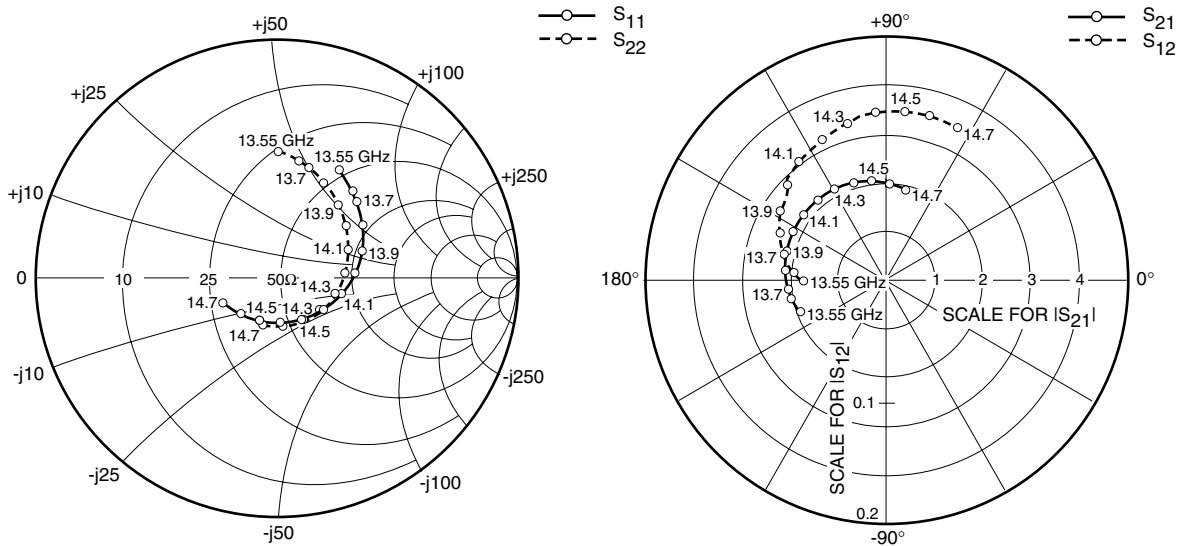

S-PARAMETERS

$V_{DS} = 10V, I_{DS} = 900mA$

FREQUENCY (MHZ)	S11		S21		S12		S22	
	MAG	ANG	MAG	ANG	MAG	ANG	MAG	ANG
1355	.522	60.0	1.928	-160.3	.071	-179.5	.527	89.5
1360	.503	54.7	1.973	-165.0	.079	176.8	.511	84.8
1365	.485	49.3	2.012	-169.9	.083	171.6	.496	79.6
1370	.461	43.5	2.044	-175.0	.087	165.4	.475	74.6
1375	.440	37.4	2.080	179.9	.090	161.9	.458	69.3
1380	.418	31.2	2.114	174.5	.096	156.3	.438	63.7
1385	.394	24.4	2.145	169.3	.102	150.8	.419	57.5
1390	.370	17.6	2.160	163.8	.105	146.9	.398	50.7
1395	.344	10.0	2.181	158.3	.109	139.7	.376	44.2
1400	.322	2.1	2.187	153.1	.115	136.8	.355	36.7
1405	.299	-6.0	2.197	147.5	.120	130.8	.333	29.1
1410	.275	-15.0	2.196	142.0	.123	127.0	.318	21.3
1415	.255	-24.8	2.193	136.5	.126	121.4	.297	12.3
1420	.235	-35.9	2.186	130.8	.128	115.3	.278	3.8
1425	.220	-46.3	2.174	125.4	.132	110.1	.263	-5.8
1430	.205	-58.6	2.152	119.9	.133	104.5	.245	-16.4
1435	.195	-71.6	2.133	114.5	.137	100.3	.232	-27.5
1440	.190	-85.3	2.107	109.0	.138	94.1	.219	-37.7
1445	.190	-98.6	2.081	103.7	.139	89.4	.209	-49.3
1450	.193	-111.2	2.042	98.7	.139	84.0	.205	-60.7
1455	.199	-123.6	2.021	93.4	.140	79.5	.204	-71.8
1460	.212	-135.6	1.984	88.3	.141	74.9	.206	-83.4
1465	.223	-146.3	1.944	83.4	.139	69.1	.205	-93.7
1470	.245	-155.5	1.909	78.2	.138	65.4	.211	-104.6

FLM1314-3F

X, Ku-Band Internally Matched FET

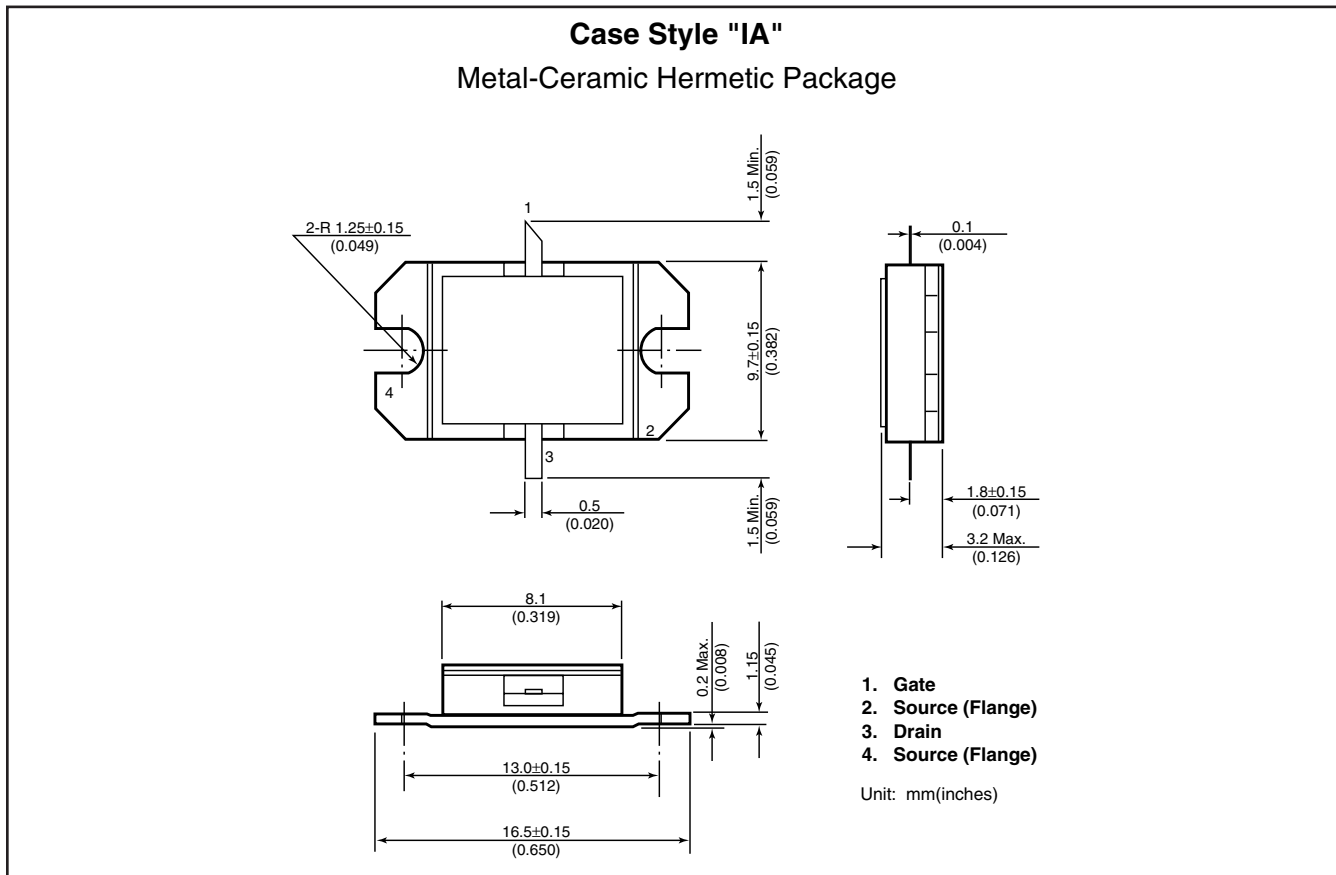

For further information please contact:

Eudyna Devices USA Inc.

2355 Zanker Rd.
San Jose, CA 95131-1138, U.S.A.
TEL: (408) 232-9500
FAX: (408) 428-9111
www.us.eudyna.com

Eudyna Devices Europe Ltd.

Network House
Norreys Drive
Maidenhead, Berkshire SL6 4FJ
United Kingdom
TEL: +44 (0) 1628 504800
FAX: +44 (0) 1628 504888

Eudyna Devices Asia Pte Ltd.

Hong Kong Branch
Rm. 1101, Ocean Centre, 5 Canton Rd.
Tsim Sha Tsui, Kowloon, Hong Kong
TEL: +852-2377-0227
FAX: +852-2377-3921

Eudyna Devices Inc.

Sales Division
1, Kanai-cho, Sakae-ku
Yokohama, 244-0845, Japan
TEL: +81-45-853-8156
FAX: +81-45-853-8170

CAUTION

Eudyna Devices Inc. products contain **gallium arsenide (GaAs)** which can be hazardous to the human body and the environment. For safety, observe the following procedures:

- Do not put this product into the mouth.
- Do not alter the form of this product into a gas, powder, or liquid through burning, crushing, or chemical processing as these by-products are dangerous to the human body if inhaled, ingested, or swallowed.
- Observe government laws and company regulations when discarding this product. This product must be discarded in accordance with methods specified by applicable hazardous waste procedures.

Eudyna Devices Inc. reserves the right to change products and specifications without notice. The information does not convey any license under rights of Eudyna Devices Inc. or others.

© 2004 Eudyna Devices USA Inc.
Printed in U.S.A.