

查询FRM5N141GW供应商
**InGaAs-APD/Preamp
Receiver**

捷多邦, 专业PCB打样工厂, 24小时加急出货

FRM5N141GW

FEATURES

- Small Form Factor Package(GW): 9 pins coplanar
- Integrated Design Optimizes Performance at Bit Rates up to 12.5Gb/s
- High Sensitivity: -27dBm (typ.)
- Electrical Differential Output
- Wide Bandwidth: 10.5GHz (typ.)
- Operates in both C and L wavelength bands



APPLICATIONS

This APD with HBT preamplifier is intended to function as an optical receiver at 1,310nm or 1,530-1,610nm in SONET, SDH, DWDM or other optical fiber systems operating up to 12.5Gb/s. The typical transimpedance (Z_t) value of $1,300\Omega$ optimizes the total bandwidth for 10Gb/s application. The detector preamplifier is DC coupled and has an electrical differential output.

DESCRIPTION

The FRM5N141GW incorporates a high bandwidth InGaAs APD photo diode, a GaAs HBT IC amplifier in a hermetically sealed Small Form Factor package (SFF). The APD is processed with modern MOVPE techniques resulting in a reliable performance over a wide range of operating conditions. The lens coupling system and the single mode fiber are assembled using Nd YAG welding.

ABSOLUTE MAXIMUM RATINGS ($T_c=25^\circ\text{C}$)

Parameter	Symbol	Ratings	Unit
Storage Temperature	T_{stg}	-40 to +85	$^\circ\text{C}$
Operating Temperature	T_{op}	-5 to +75	$^\circ\text{C}$
Supply Voltage	V_{ss}	-6 to 0	V
PIN Reverse Voltage	V_R	0 to V_B (Note)	V
PIN Reverse Current	$I_{R(peak)}$	3	mA

Note: Since V_B may vary from device-to-device, V_B data is attached to each device for reference.

OPTICAL & ELECTRICAL CHARACTERISTICS

(T_C=25°C, λ=1,550nm, V_{SS}=-5.2V, unless otherwise specified)

Parameter	Symbol	Test Conditions	Limits			Unit	
			Min.	Typ.	Max.		
APD Responsivity	R13	λ = 1,310nm, M=1	0.75	0.85	-	A/W	
	R15	λ = 1,550nm, M=1	0.75	0.90	-		
	R16	λ = 1,610nm, M=1	-	0.80	-		
APD Breakdown Voltage	VB	ID = 10μA	20.0	25.0	30.0	V	
Temperature Coefficient of VB	γ	Note (1)	0.03	0.05	0.07	V/°C	
AC Transimpedance	Z _t	f = 750MHz, Single-end	900	1300	-	Ω	
Output Common Voltage	V _{out}	-	-	-400	-	mV	
Maximum Output Voltage Swing	V _{clip}	Saturated Output Voltage	400	600	800	mV	
Bandwidth	BW	-3dB from 750MHz, Pin=-20dBm	M=9	8.5	10.5	-	GHz
			M=3	8.5	10.5	-	
Lower Cut-off Frequency	f _{cl}	-3dB from 750MHz, Pin=-20dBm	-	40	100	kHz	
Peaking	d _{pk}	130MHz to BW, Pin=-20dBm, M=9	-	0.5	1.5	dB	
Group Delay Deviation	GD	1GHz to 6GHz, Pin=-20dBm, M=9	-	15	40	ps _{p-p}	
		1GHz to 8GHz, Pin=-20dBm, M=9	-	30	60		
Output Return Loss	S ₂₂	130MHz to 6GHz	-	12	-	dB	
		130MHz to 8GHz	-	10	-		
Minimum Sensitivity	P _r	10Gb/s, NRZ, PRBS=2 ³¹ -1, B.E.R.=10 ⁻¹² , VR=Optimum	25°C, R _{ext} =13dB	-	-27.0	-25.0	dBm
			25°C, R _{ext} =10dB	-	-26.0	-	
			25°C, R _{ext} =8.2dB	-	-25.0	-	
			70°C, R _{ext} =13dB	-	-26.0	-24.0	
Maximum Overload	P _o	10Gb/s, NRZ, PRBS=2 ³¹ -1, B.E.R.=10 ⁻¹² , M=3	R _{ext} =13dB	-7	-5	-	dBm
			R _{ext} =10dB	-	-4.5	-	
			R _{ext} =8.2dB	-	-4.0	-	
Optical Return Loss	ORL	λ = 1,550nm	27	-	-	dB	
		λ = 1,310nm	27	-	-		
Power Supply Current	I _{SS}	-	-	110	130	mA	
Power Supply Voltage	V _{SS}	-	-5.46	-5.20	-4.94	V	
Thermistor Resistance	R _{th}	-	9.5	10.0	10.5	kΩ	
Thermistor B Constant	B	-	3800	3900	4000	K	

Note 1: γ=ΔVB/dT_C

Note: All the parameters are measured with 50Ω, DC-coupled and 0V output offset.

InGaAs-APD/Preamp Receiver _____ ***FRM5N141GW***

Notes

FRM5N141GW

InGaAs-APD/Preamp Receiver

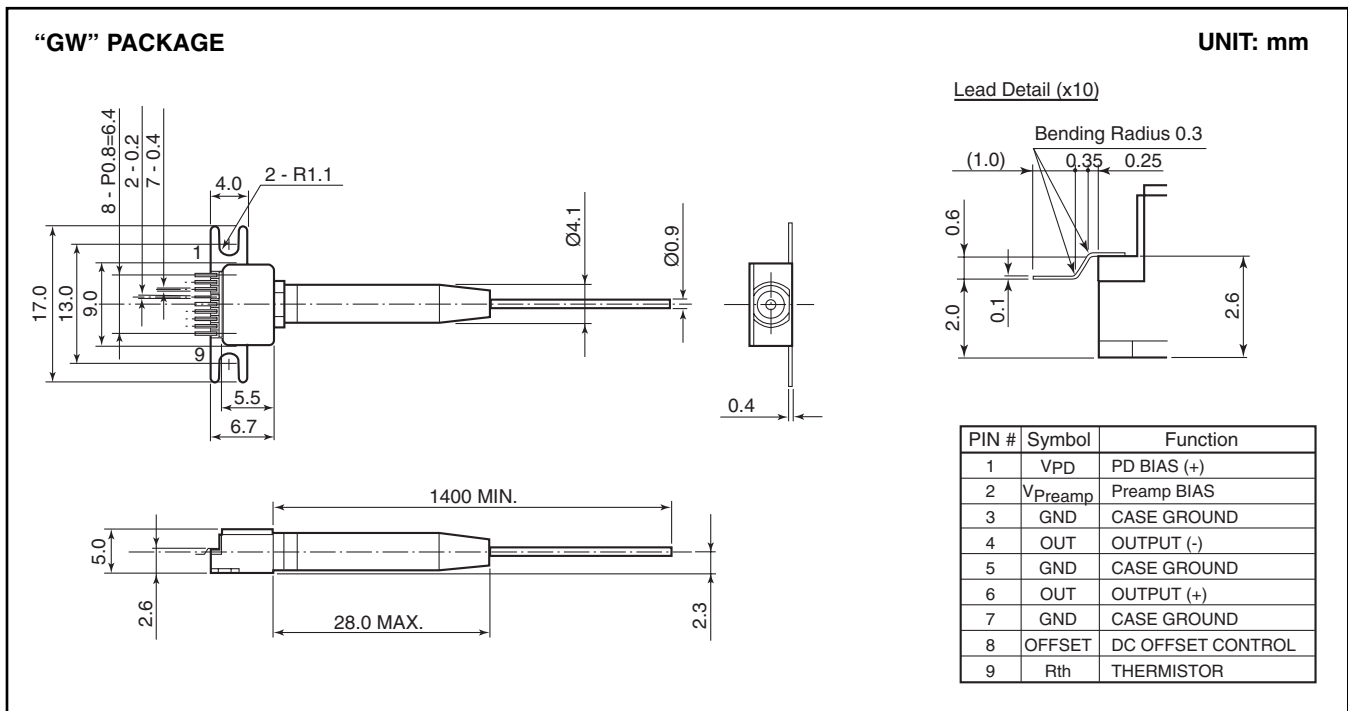

For further information please contact:

FUJITSU COMPOUND SEMICONDUCTOR, INC.

2355 Zanker Rd.
 San Jose, CA 95131-1138, U.S.A.
 Phone: (408) 232-9500
 FAX: (408) 428-9111
www.fcsi.fujitsu.com

FUJITSU QUANTUM DEVICES EUROPE LTD.

Network House
 Norreys Drive
 Maidenhead, Berkshire SL6 4FJ
 United Kingdom
 TEL: +44 (0) 1628 504800
 FAX: +44 (0) 1628 504888

FUJITSU QUANTUM DEVICES SINGAPORE PTE LTD.

Hong Kong Branch
 Rm. 1101, Ocean Centre, 5 Canton Rd. Tsim Sha Tsui,
 Kowloon, Hong Kong
 TEL: +852-23770226
 FAX: +852-23763269

CAUTION

Fujitsu Compound Semiconductor Products contain **gallium arsenide (GaAs)** which can be hazardous to the human body and the environment. For safety, observe the following procedures:

- Do not put this product into the mouth.
- Do not alter the form of this product into a gas, powder, or liquid through burning, crushing, or chemical processing as these by-products are dangerous to the human body if inhaled, ingested, or swallowed.
- Observe government laws and company regulations when discarding this product. This product must be discarded in accordance with methods specified by applicable hazardous waste procedures.

FUJITSU QUANTUM DEVICES LIMITED

Business Development Division
 11th Floor, Hachioji Daiichi-Seimei Bldg.
 3-20-6 Myojin-cho
 Hachioji-city, Tokyo 192-0046, Japan
 TEL: +81-426-43-5885
 FAX: +81-426-43-5582

Fujitsu Limited reserves the right to change products and specifications without notice. The information does not convey any license under rights of Fujitsu Limited or others.

© 2002 FUJITSU COMPOUND SEMICONDUCTOR, INC.
 Printed in U.S.A. FCSI0302M200

