

DEC

FR801 THRU FR807

CURRENT 8.0 Amperes
VOLTAGE 50 to 1000 Volts

Features

- Fast switching
- Low leakage
- Low forward voltage drop
- High current capability
- High current surge
- High reliability

TO-220A

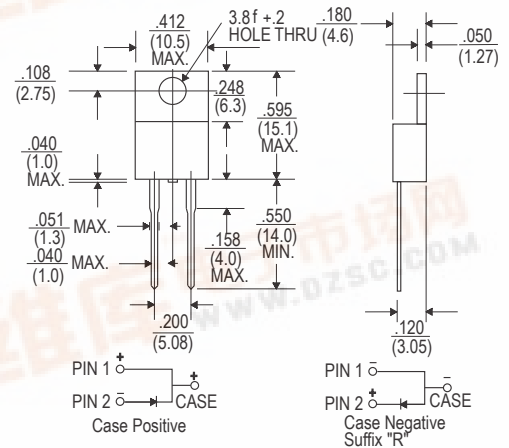

Mechanical Data

- Case : JEDEC TO-220A molded plastic body
- Terminals : Lead solderable per MIL-STD-750, method 2026
- Polarity : As marked
- Mounting Position : Any
- Weight : 0.08 ounce, 2.24 gram

Dimensions in inches and (millimeters)

Maximum Ratings And Electrical Characteristics

(Ratings at 25 °C ambient temperature unless otherwise specified, Single phase, half wave 60Hz, resistive or inductive load. For capacitive load, derate by 20%)

	Symbols	FR 801	FR 802	FR 803	FR 804	FR 805	FR 806	FR 807	Units
Maximum recurrent peak reverse voltage	V _{RRM}	50	100	200	400	600	800	1000	Volts
Maximum RMS voltage	V _{RMS}	35	70	140	280	420	560	700	Volts
Maximum DC blocking voltage	V _{DC}	50	100	200	400	600	800	1000	Volts
Maximum average forward rectified current at T _c =55 °C	I(AV)	8.0							Amps
Peak forward surge current 8.3ms single half sine-wave superimposed on rated load (JEDEC method)	I _{FSM}	150							Amps
Maximum instantaneous forward voltage at 8.0A	V _F	1.3							Volts
Maximum DC reverse current at rated DC blocking voltage	I _R	10							μA
		100							
Maximum reverse recovery time (Note 1)	T _{rr}	150				250	500		ns
Typical junction capacitance (Note 2) T _J =25 °C	C _J	60							pF
Typical thermal resistance (Note 3)	R _{θJC}	3.0							°C/W
Operating junction and storage temperature range	T _J T _{STG}	-55 to +150							°C

(1) Test conditions: I_F=0.5A, I_R=1.0A, I_{rr}=0.25A.

(2) Measured at 1MHz and applied reverse voltage of 4.0 Volts.





RATINGS AND CHARACTERISTIC CURVES FR801 THRU FR807

FIG. 1 -REVERSE RECOVERY TIME CHARACTERISTIC AND TEST CIRCUIT DIAGRAM

