



June 2007

Motion-SPM™

FSBF3CH60B Smart Power Module

Features

- UL Certified No.E209204(SPM27-JA package)
- 600V-3A 3-phase IGBT inverter bridge including control ICs for gate driving and protection
- Easy PCB layout due to built in bootstrap diode
- Divided negative dc-link terminals for inverter current sensing applications
- Single-grounded power supply due to built-in HVIC
- Isolation rating of 2500Vrms/min.

Applications

- AC 100V ~ 253V three-phase inverter drive for small power ac motor drives
- Home appliances applications like air conditioner and washing machine

General Description

It is an advanced motion-smart power module (Motion-SPM™) that Fairchild has newly developed and designed to provide very compact and high performance ac motor drives mainly targeting low-power inverter-driven application like air conditioner and washing machine. It combines optimized circuit protection and drive matched to low-loss IGBTs. System reliability is further enhanced by the integrated under-voltage lock-out and short-circuit protection. The high speed built-in HVIC provides opto-coupler-less single-supply IGBT gate driving capability that further reduce the overall size of the inverter system design. Each phase current of inverter can be monitored separately due to the divided negative dc terminals.

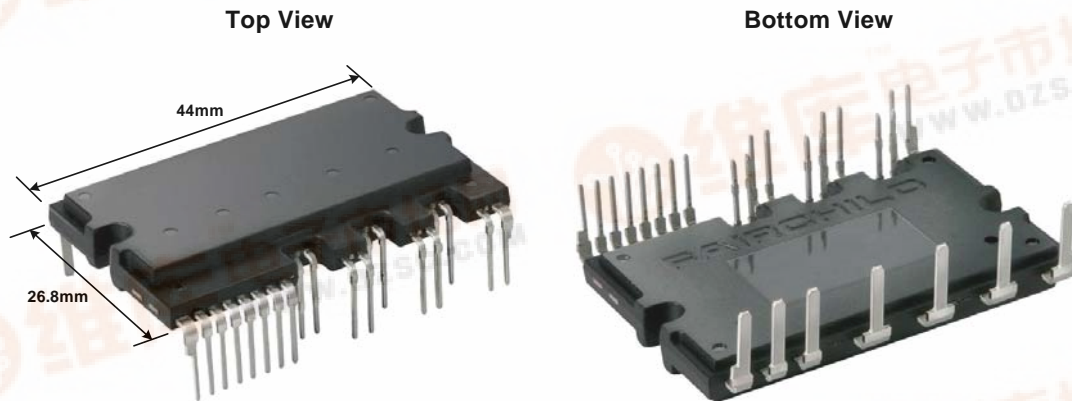

Figure 1.



Integrated Power Functions

- 600V-3A IGBT inverter for three-phase DC/AC power conversion (Please refer to Figure 3)

Integrated Drive, Protection and System Control Functions

- For inverter high-side IGBTs: Gate drive circuit, High voltage isolated high-speed level shifting
Control circuit under-voltage (UV) protection
Note) Available bootstrap circuit example is given in Figures 10 and 11.
- For inverter low-side IGBTs: Gate drive circuit, Short circuit protection (SC)
Control supply circuit under-voltage (UV) protection
- Fault signaling: Corresponding to UV (Low-side supply) and SC faults
- Input interface: 3.3/5V CMOS/LSTTL compatible, Schmitt trigger input

Pin Configuration

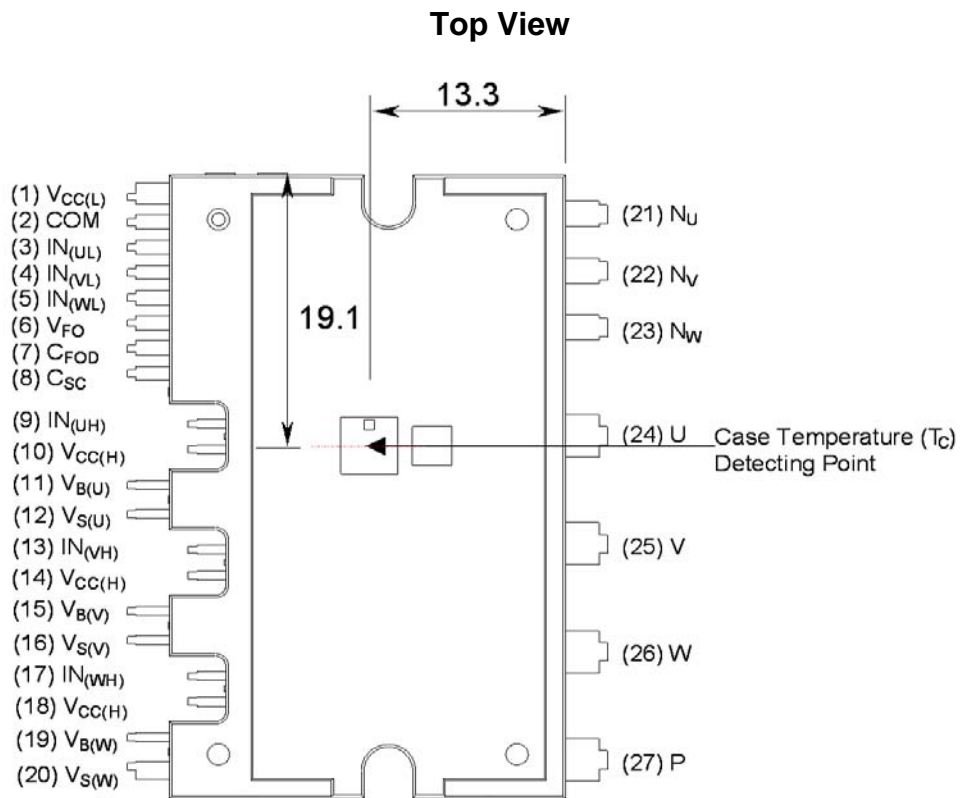

Pin Descriptions

Pin Number	Pin Name	Pin Description
1	V _{CC(L)}	Low-side Common Bias Voltage for IC and IGBTs Driving
2	COM	Common Supply Ground
3	IN _(UL)	Signal Input for Low-side U Phase
4	IN _(VL)	Signal Input for Low-side V Phase
5	IN _(WL)	Signal Input for Low-side W Phase
6	V _{FO}	Fault Output
7	C _{FOD}	Capacitor for Fault Output Duration Time Selection
8	C _{SC}	Capacitor (Low-pass Filter) for Short-Current Detection Input
9	IN _(UH)	Signal Input for High-side U Phase
10	V _{CC(H)}	High-side Common Bias Voltage for IC and IGBTs Driving
11	V _{B(U)}	High-side Bias Voltage for U Phase IGBT Driving
12	V _{S(U)}	High-side Bias Voltage Ground for U Phase IGBT Driving
13	IN _(VH)	Signal Input for High-side V Phase
14	V _{CC(H)}	High-side Common Bias Voltage for IC and IGBTs Driving
15	V _{B(V)}	High-side Bias Voltage for V Phase IGBT Driving
16	V _{S(V)}	High-side Bias Voltage Ground for V Phase IGBT Driving
17	IN _(WH)	Signal Input for High-side W Phase
18	V _{CC(H)}	High-side Common Bias Voltage for IC and IGBTs Driving
19	V _{B(W)}	High-side Bias Voltage for W Phase IGBT Driving
20	V _{S(W)}	High-side Bias Voltage Ground for W Phase IGBT Driving
21	N _U	Negative DC-Link Input for U Phase
22	N _V	Negative DC-Link Input for V Phase
23	N _W	Negative DC-Link Input for W Phase
24	U	Output for U Phase
25	V	Output for V Phase
26	W	Output for W Phase
27	P	Positive DC-Link Input

Internal Equivalent Circuit and Input/Output Pins

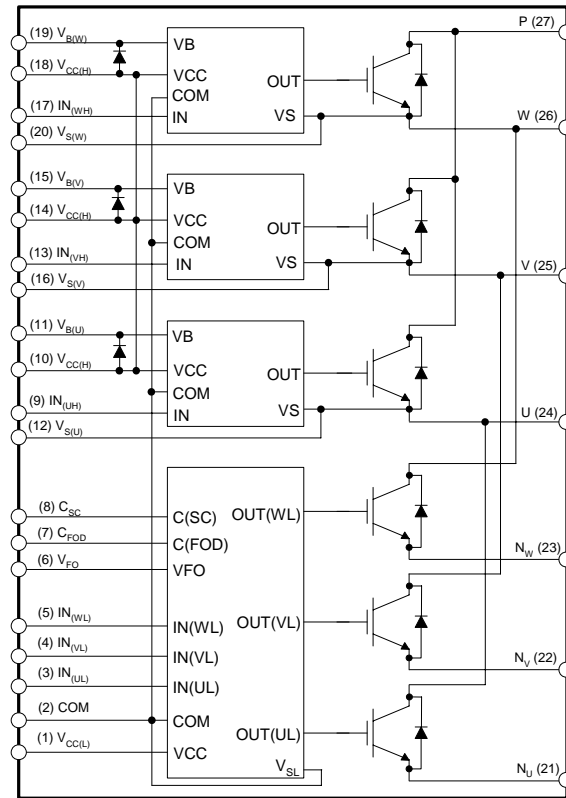

Note:

1. Inverter low-side is composed of three IGBTs, freewheeling diodes for each IGBT and one control IC. It has gate drive and protection functions.
2. Inverter power side is composed of four inverter dc-link input terminals and three inverter output terminals.
3. Inverter high-side is composed of three IGBTs, freewheeling diodes and three drive ICs for each IGBT.

Figure 3.

Absolute Maximum Ratings (T_J = 25°C, Unless Otherwise Specified)

Inverter Part

Symbol	Parameter	Conditions	Rating	Units
V _{PN}	Supply Voltage	Applied between P- N _U , N _V , N _W	450	V
V _{PN(Surge)}	Supply Voltage (Surge)	Applied between P- N _U , N _V , N _W	500	V
V _{CES}	Collector-emitter Voltage		600	V
± I _C	Each IGBT Collector Current	T _C = 25°C	3	A
± I _{CP}	Each IGBT Collector Current (Peak)	T _C = 25°C, Under 1ms Pulse Width	6	A
P _C	Collector Dissipation	T _C = 25°C per One Chip	19	W
T _J	Operating Junction Temperature	(Note 1)	-40 ~ 150	°C

Note:

1. The maximum junction temperature rating of the power chips integrated within the SPM is 150°C(@T_C ≤ 125°C).

Control Part

Symbol	Parameter	Conditions	Rating	Units
V _{CC}	Control Supply Voltage	Applied between V _{CC(H)} , V _{CC(L)} - COM	20	V
V _{BS}	High-side Control Bias Voltage	Applied between V _{B(U)} - V _{S(U)} , V _{B(V)} - V _{S(V)} , V _{B(W)} - V _{S(W)}	20	V
V _{IN}	Input Signal Voltage	Applied between IN _(UH) , IN _(VH) , IN _(WH) , IN _(UL) , IN _(VL) , IN _(WL) - COM	-0.3~17	V
V _{FO}	Fault Output Supply Voltage	Applied between V _{FO} - COM	-0.3~V _{CC} +0.3	V
I _{FO}	Fault Output Current	Sink Current at V _{FO} Pin	5	mA
V _{SC}	Current Sensing Input Voltage	Applied between C _{SC} - COM	-0.3~V _{CC} +0.3	V
T _{J(Driver IC)}	Operating Junction Temperature		-40 ~ 150	°C

Bootstrap Diode Part

Symbol	Parameter	Conditions	Rating	Units
V _{RRM}	Maximum Repetitive Reverse Voltage		600	V
I _F	Forward Current	T _C = 25°C	0.5	A
I _{FP}	Forward Current (Peak)	T _C = 25°C, Under 1ms Pulse Width	2	A
T _J	Operating Junction Temperature		-40 ~ 150	°C

Total System

Symbol	Parameter	Conditions	Rating	Units
V _{PN(PROT)}	Self Protection Supply Voltage Limit (Short Circuit Protection Capability)	V _{CC} = V _{BS} = 13.5 ~ 16.5V T _J = 150°C, Non-repetitive, less than 2μs	400	V
T _C	Module Case Operation Temperature	-40°C ≤ T _J ≤ 150°C, See Figure 2	-40 ~ 125	°C
T _{STG}	Storage Temperature		-40 ~ 150	°C
V _{ISO}	Isolation Voltage	60Hz, Sinusoidal, AC 1 minute, Connection Pins to heat sink plate	2500	V _{rms}

Thermal Resistance

Symbol	Parameter	Conditions	Min.	Typ.	Max.	Units
R _{th(j-c)Q}	Junction to Case Thermal Resistance	Inverter IGBT part (per 1/6 module)	-	-	6.5	°C/W
R _{th(j-c)F}		Inverter FWD part (per 1/6 module)	-	-	6.9	°C/W

Note:

2. For the measurement point of case temperature(T_C), please refer to Figure 2.

Electrical Characteristics (T_J = 25°C, Unless Otherwise Specified)

Inverter Part

Symbol	Parameter	Conditions	Min.	Typ.	Max.	Units	
V _{CE(SAT)}	Collector-Emitter Saturation Voltage	V _{CC} = V _{BS} = 15V V _{IN} = 5V	-	-	2.0	V	
V _F	FWD Forward Voltage	V _{IN} = 0V	-	-	2.1	V	
HS	Switching Times	V _{PN} = 300V, V _{CC} = V _{BS} = 15V I _C = 3A V _{IN} = 0V ↔ 5V, Inductive Load (Note 3)	t _{ON}	-	0.75	-	μs
			t _{C(ON)}	-	0.15	-	μs
			t _{OFF}	-	0.60	-	μs
			t _{C(OFF)}	-	0.20	-	μs
			t _{rr}	-	0.15	-	μs
LS	Switching Times	V _{PN} = 300V, V _{CC} = V _{BS} = 15V I _C = 3A V _{IN} = 0V ↔ 5V, Inductive Load (Note 3)	t _{ON}	-	0.45	-	μs
			t _{C(ON)}	-	0.20	-	μs
			t _{OFF}	-	0.60	-	μs
			t _{C(OFF)}	-	0.20	-	μs
			t _{rr}	-	0.20	-	μs
I _{CES}	Collector-Emitter Leakage Current	V _{CE} = V _{CES}	-	-	1	mA	

Note:

3. t_{ON} and t_{OFF} include the propagation delay time of the internal drive IC. t_{C(ON)} and t_{C(OFF)} are the switching time of IGBT itself under the given gate driving condition internally. For the detailed information, please see Figure 4.

Control Part

Symbol	Parameter	Conditions	Min.	Typ.	Max.	Units
I _{QCCL}	Quiescent V _{CC} Supply Current	V _{CC} = 15V I _{N(UH, VH, WH)} = 0V	-	-	23	mA
I _{QCCH}		V _{CC} = 15V I _{N(UH, VH, WH)} = 0V	-	-	600	μA
I _{QBS}	Quiescent V _{BS} Supply Current	V _{BS} = 15V I _{N(UH, VH, WH)} = 0V	-	-	500	μA
V _{FOH}	Fault Output Voltage	V _{SC} = 0V, V _{FO} Circuit: 4.7kΩ to 5V Pull-up	4.5	-	-	V
V _{FOL}		V _{SC} = 1V, V _{FO} Circuit: 4.7kΩ to 5V Pull-up	-	-	0.8	V
V _{SC(ref)}	Short Circuit Trip Level	V _{CC} = 15V (Note 4)	0.45	0.5	0.55	V
TSD	Over-temperature protection	Temperature at LVIC	-	160	-	°C
ΔTSD	Over-temperature protection hysteresis	Temperature at LVIC	-	5	-	°C
UV _{CCD}	Supply Circuit Under-Voltage Protection	Detection Level	10.7	11.9	13.0	V
UV _{CCR}		Reset Level	11.2	12.4	13.4	V
UV _{BSD}		Detection Level	10	11	12	V
UV _{BSR}		Reset Level	10.5	11.5	12.5	V
t _{FOD}	Fault-out Pulse Width	C _{FOD} = 33nF (Note 5)	1.0	1.8	-	ms
V _{IN(ON)}	ON Threshold Voltage	Applied between I _{N(UH)} , I _{N(VH)} , I _{N(WH)} , I _{N(UL)} , I _{N(VL)} , I _{N(WL)} - COM	2.8	-	-	V
V _{IN(OFF)}	OFF Threshold Voltage		-	-	0.8	V

Note:

4. Short-circuit current protection is functioning only at the low-sides.
 5. The fault-out pulse width t_{FOD} depends on the capacitance value of C_{FOD} according to the following approximate equation : C_{FOD} = 18.3 × 10⁻⁶ × t_{FOD}[F]

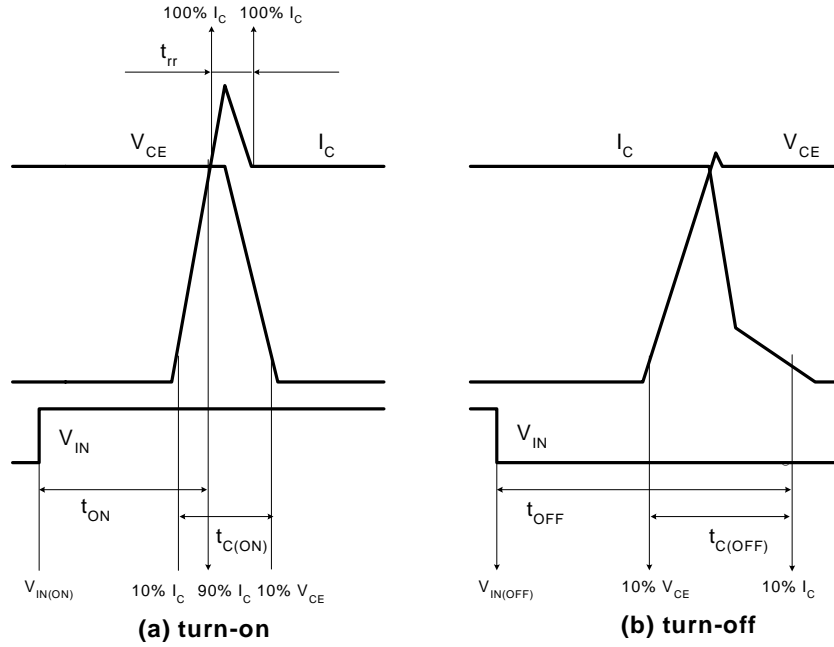

Figure 4. Switching Time Definition

Switching Loss (Typical)

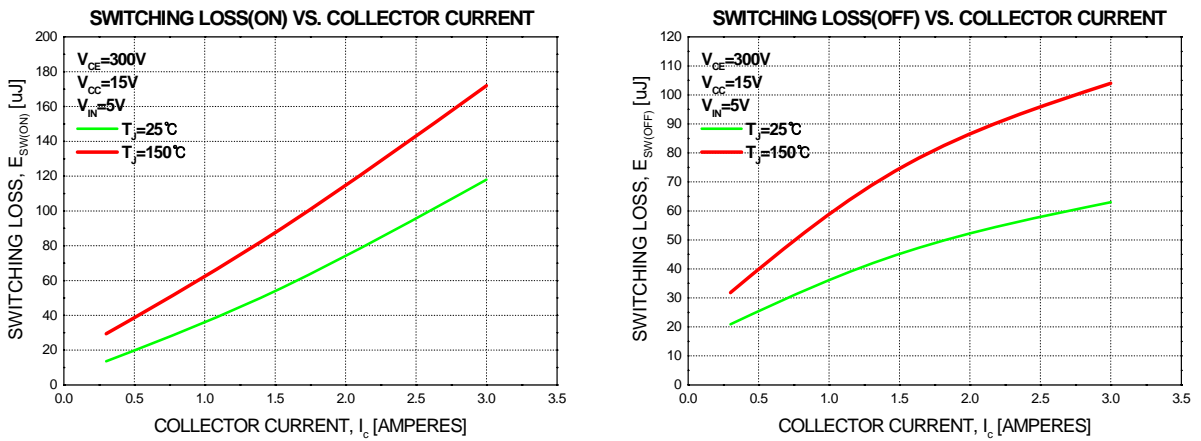
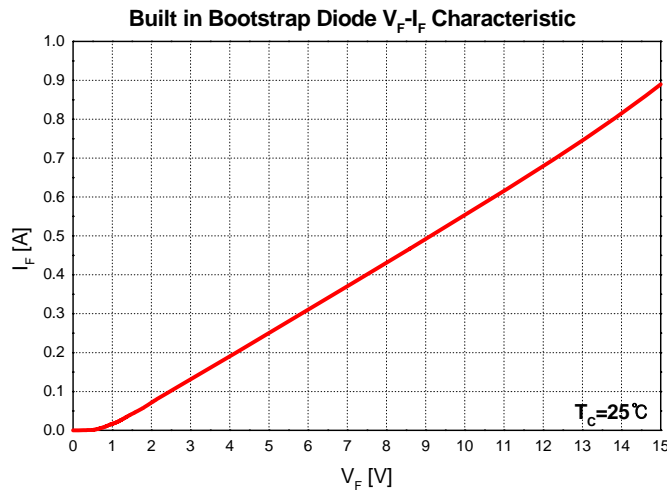

Figure 5. Switching Loss Characteristics

Bootstrap Diode Part

Symbol	Parameter	Conditions	Min.	Typ.	Max.	Units
V_F	Forward Voltage	$I_F = 0.1A, T_C = 25^\circ C$	-	2.5	-	V
t_{rr}	Reverse Recovery Time	$I_F = 0.1A, T_C = 25^\circ C$	-	80	-	ns



Note:

6. Built in bootstrap diode includes around 15Ω resistance characteristic.

Figure 6. Built in Bootstrap Diode Characteristics

Recommended Operating Conditions

Symbol	Parameter	Conditions	Value			Units
			Min.	Typ.	Max.	
V_{PN}	Supply Voltage	Applied between P - N_U, N_V, N_W	-	300	400	V
V_{CC}	Control Supply Voltage	Applied between $V_{CC(H)}, V_{CC(L)}$ - COM	13.5	15	16.5	V
V_{BS}	High-side Bias Voltage	Applied between $V_{B(U)} - V_{S(U)}, V_{B(V)} - V_{S(V)}, V_{B(W)} - V_{S(W)}$	13.0	15	18.5	V
$dV_{CC}/dt, dV_{BS}/dt$	Control supply variation		-1	-	1	V/ μs
t_{dead}	Blanking Time for Preventing Arm-short	For Each Input Signal	1.5	-	-	μs
f_{PWM}	PWM Input Signal	$-40^\circ C \leq T_C \leq 125^\circ C, -40^\circ C \leq T_J \leq 150^\circ C$	-	-	20	kHz
V_{SEN}	Voltage for Current Sensing	Applied between N_U, N_V, N_W - COM (Including surge voltage)	-4		4	V

Mechanical Characteristics and Ratings

Parameter	Conditions		Limits			Units
			Min.	Typ.	Max.	
Mounting Torque	Mounting Screw: - M3	Recommended 0.62N•m	0.51	0.62	1.00	N•m
Device Flatness		Note Figure 7	0	-	+120	μm
Weight			-	15.4	-	g

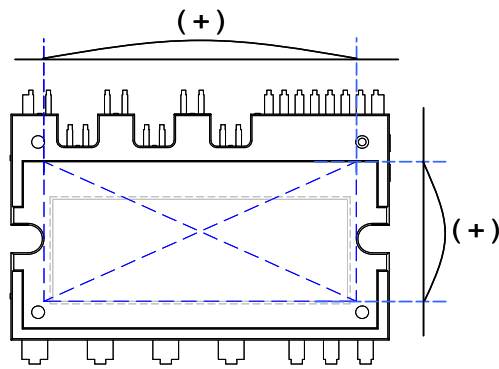
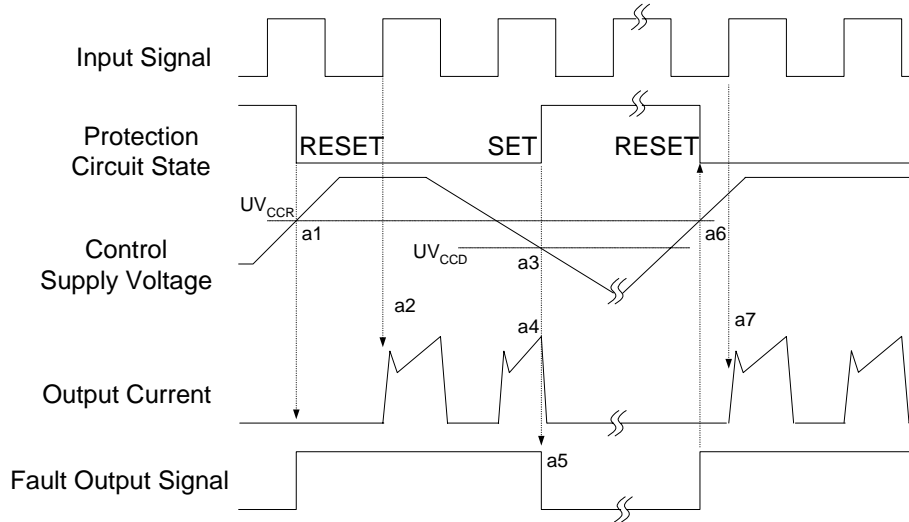

Figure 7. Flatness Measurement Position

Package Marking and Ordering Information

Device Marking	Device	Package	Reel Size	Tape Width	Quantity
FSBF3CH60B	FSBF3CH60B	SPM27-JA	-	-	10

Time Charts of SPMs Protective Function



- a1 : Control supply voltage rises: After the voltage rises UV_{CCR} , the circuits start to operate when next input is applied.
- a2 : Normal operation: IGBT ON and carrying current.
- a3 : Under voltage detection (UV_{CCD}).
- a4 : IGBT OFF in spite of control input condition.
- a5 : Fault output operation starts.
- a6 : Under voltage reset (UV_{CCR}).
- a7 : Normal operation: IGBT ON and carrying current.

Figure 8. Under-Voltage Protection (Low-side)

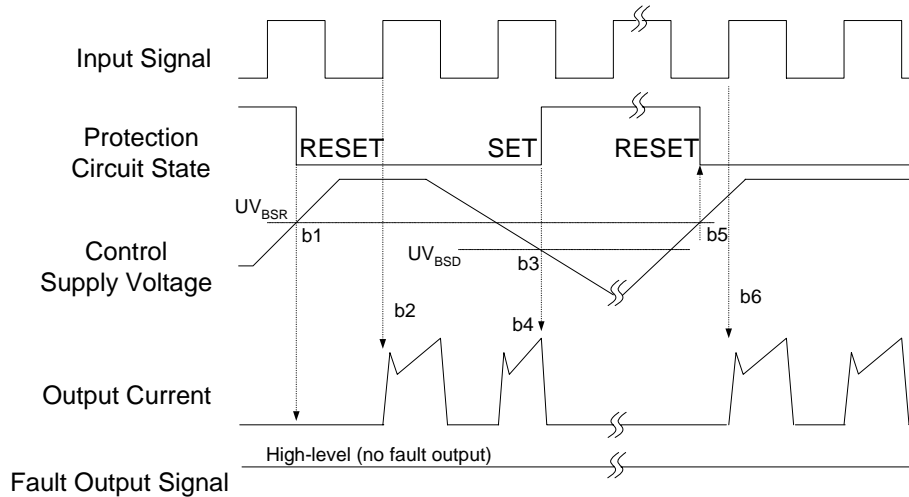

- b1 : Control supply voltage rises: After the voltage reaches UV_{BSR} , the circuits start to operate when next input is applied.
- b2 : Normal operation: IGBT ON and carrying current.
- b3 : Under voltage detection (UV_{BSD}).
- b4 : IGBT OFF in spite of control input condition, but there is no fault output signal.
- b5 : Under voltage reset (UV_{BSR})
- b6 : Normal operation: IGBT ON and carrying current

Figure 9. Under-Voltage Protection (High-side)

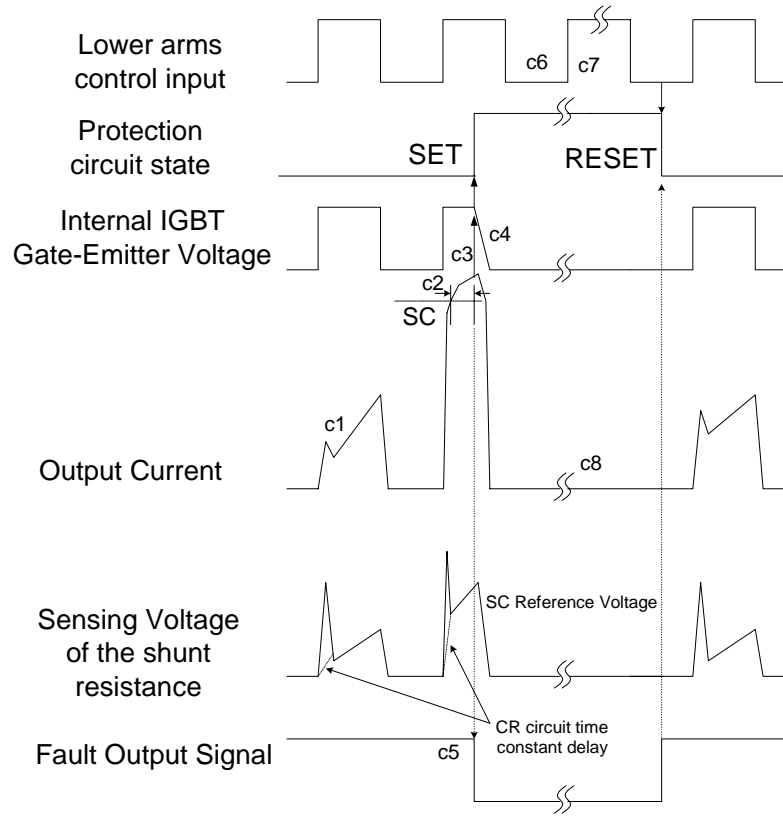

(with the external shunt resistance and CR connection)

c1 : Normal operation: IGBT ON and carrying current.

c2 : Short circuit current detection (SC trigger).

c3 : Hard IGBT gate interrupt.

c4 : IGBT turns OFF.

c5 : Fault output timer operation starts: The pulse width of the fault output signal is set by the external capacitor C_{FO} .

c6 : Input "L" : IGBT OFF state.

c7 : Input "H": IGBT ON state, but during the active period of fault output the IGBT doesn't turn ON.

c8 : IGBT OFF state

Figure 10. Short-Circuit Current Protection (Low-side Operation only)

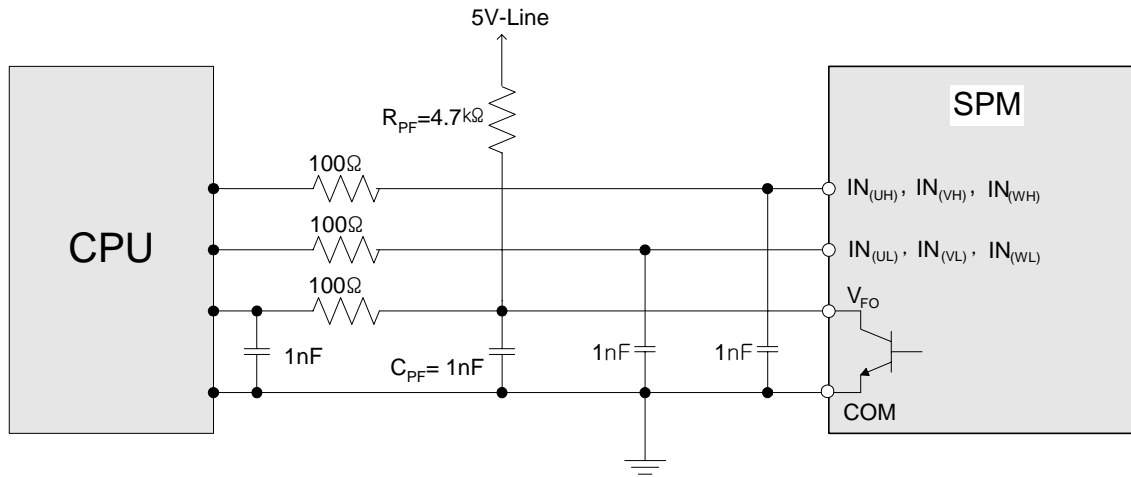

Note:

- 1) RC coupling at each input might change depending on the PWM control scheme used in the application and the wiring impedance of the application's printed circuit board. The SPM input signal section integrates 5kΩ (typ.) pull-down resistor. Therefore, when using an external filtering resistor, please pay attention to the signal voltage drop at input terminal.
- 2) The logic input is compatible with standard CMOS or LSTTL outputs.

Figure 11. Recommended CPU I/O Interface Circuit

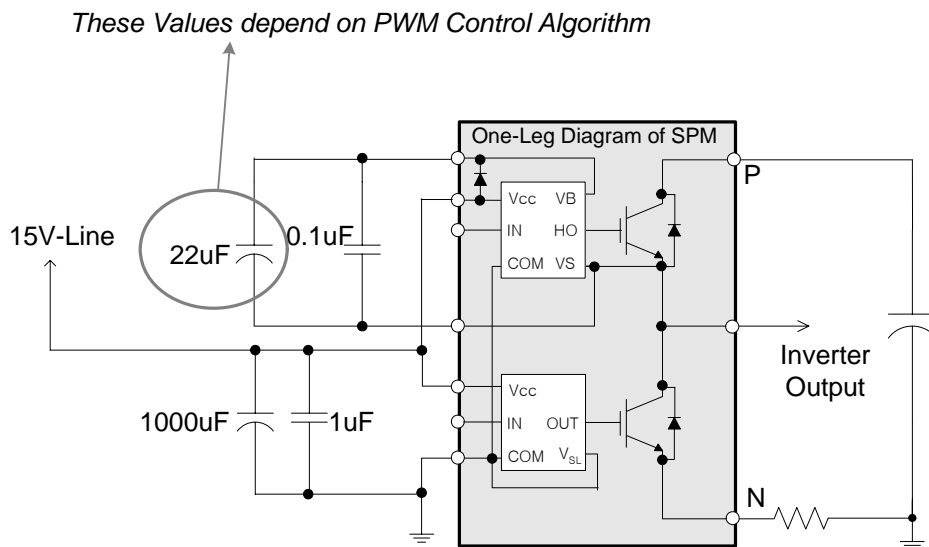

Note:

- 1) The ceramic capacitor placed between V_{CC}-COM should be over 1uF and mounted as close to the pins of the SPM as possible.

Figure 12. Recommended Bootstrap Operation Circuit and Parameters

Detailed Package Outline Drawings

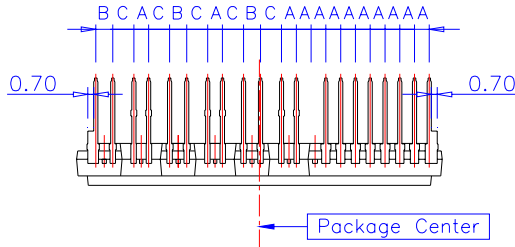

Lead Pitch : ± 0.30
 A : 1.778
 B : 2.050
 C : 2.531

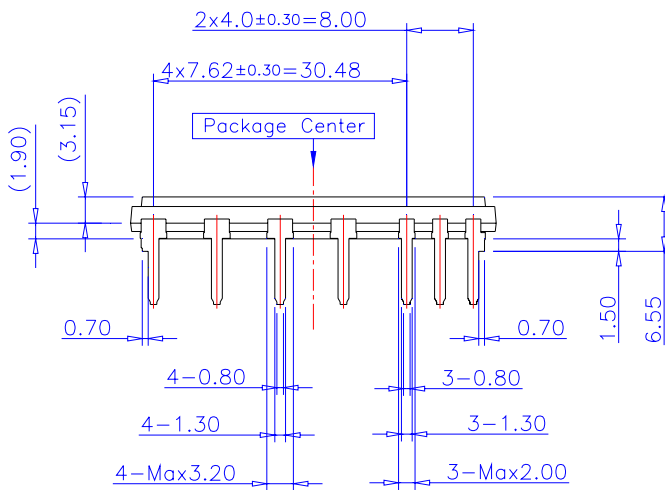
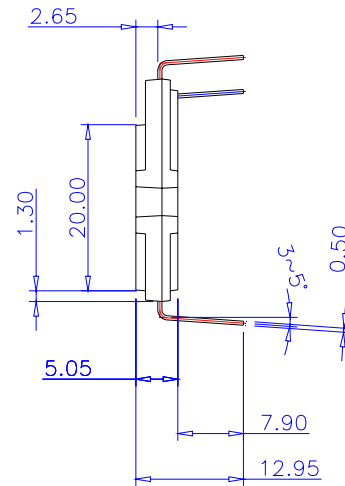
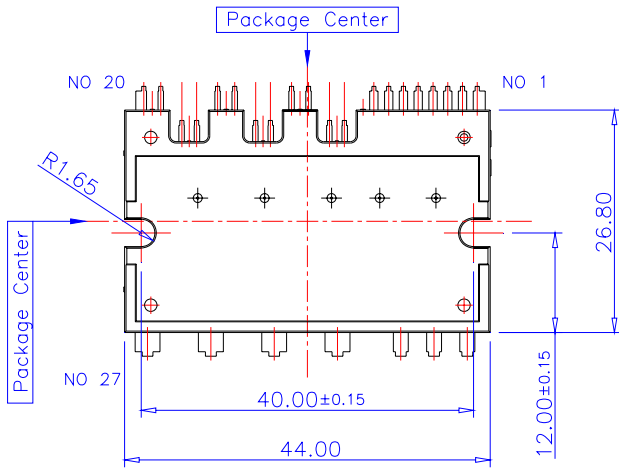

Detailed Package Outline Drawings (Continued)

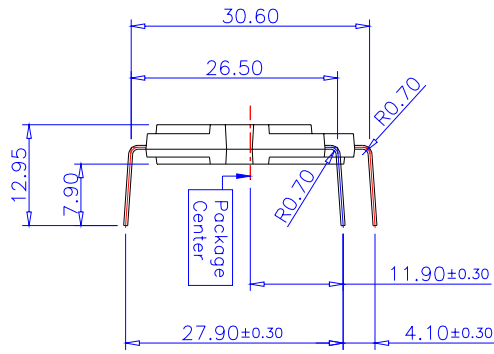

Lead Forming Dimension

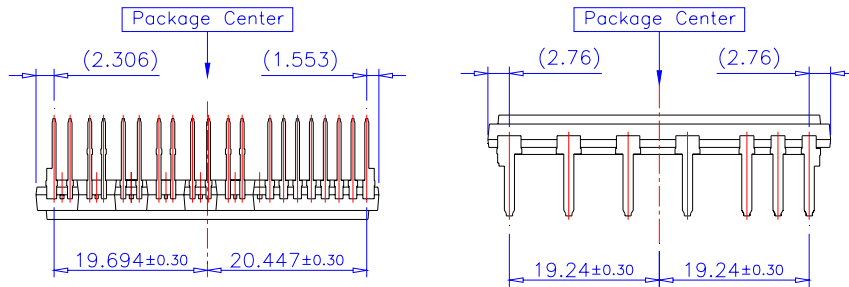

PKG Center to Lead Distance

Detailed Package Outline Drawings (Continued)

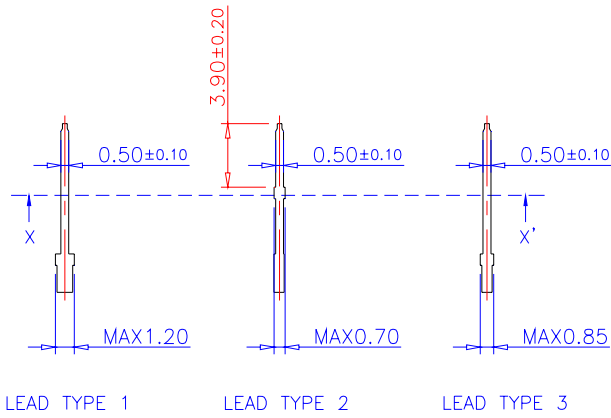
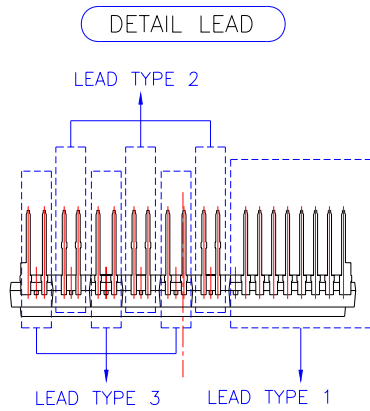

SCALE 2 : 1

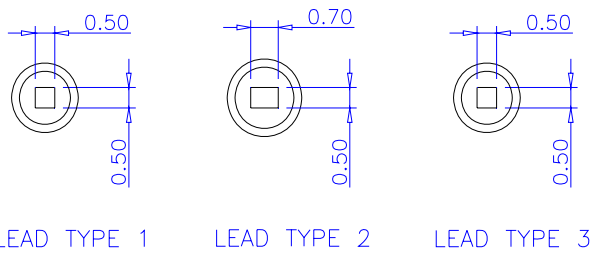

SCALE 5 : 1

LEAD SECTION X-X'



TRADEMARKS

The following are registered and unregistered trademarks and service marks Fairchild Semiconductor owns or is authorized to use and is not intended to be an exhaustive list of all such trademarks.

ACE ^x [®]	Green FPS [™] e-Series [™]	Power-SPM [™]	SyncFET [™]
Build it Now [™]	GTO [™]	PowerTrench [®]	The Power Franchise [®]
CorePLU [™]	<i>i-Lo</i> [™]	Programmable Active Droop [™]	 [™]
CROSSVOL [™]	IntelliMAX [™]	QFET [®]	TinyBoost [™]
CTL [™]	ISOPLANAR [™]	QS [™]	TinyBuck [™]
Current Transfer Logic [™]	MegaBuck [™]	QT Optoelectronics [™]	TinyLogic [®]
EcoSPARK [®]	MICROCOUPLER [™]	Quiet Series [™]	TINYOPTO [™]
FACT Quiet Series [™]	MicroPak [™]	RapidConfigure [™]	TinyPower [™]
FACT [®]	Motion-SPM [™]	SMART START [™]	TinyPWM [™]
FAST [®]	OPTOLOGIC [®]	SPM [®]	TinyWire [™]
FastvCore [™]	OPTOPLANAR [®]	STEALTH [™]	μSerDes [™]
FPST [™]	PDP-SPM [™]	SuperFET [™]	UHC [®]
FRFET [®]	Power220 [®]	SuperSOT [™] -3	UniFET [™]
Global Power Resource SM	Power247 [®]	SuperSOT [™] -6	VCX [™]
Green FPS [™]	POWEREDGE [®]	SuperSOT [™] -8	

DISCLAIMER

FAIRCHILD SEMICONDUCTOR RESERVES THE RIGHT TO MAKE CHANGES WITHOUT FURTHER NOTICE TO ANY PRODUCTS HEREIN TO IMPROVE RELIABILITY, FUNCTION, OR DESIGN. FAIRCHILD DOES NOT ASSUME ANY LIABILITY ARISING OUT OF THE APPLICATION OR USE OF ANY PRODUCT OR CIRCUIT DESCRIBED HEREIN; NEITHER DOES IT CONVEY ANY LICENSE UNDER ITS PATENT RIGHTS, NOR THE RIGHTS OF OTHERS. THESE SPECIFICATIONS DO NOT EXPAND THE TERMS OF FAIRCHILD'S WORLDWIDE TERMS AND CONDITIONS, SPECIFICALLY THE WARRANTY THEREIN, WHICH COVERS THESE PRODUCTS.

LIFE SUPPORT POLICY

FAIRCHILD'S PRODUCTS ARE NOT AUTHORIZED FOR USE AS CRITICAL COMPONENTS IN LIFE SUPPORT DEVICES OR SYSTEMS WITHOUT THE EXPRESS WRITTEN APPROVAL OF FAIRCHILD SEMICONDUCTOR CORPORATION.

As used herein:

1. Life support devices or systems are devices or systems which, (a) are intended for surgical implant into the body, or (b) support or sustain life, and (c) whose failure to perform when properly used in accordance with instructions for use provided in the labeling, can be reasonably expected to result in significant injury to the user.
2. A critical component is any component of a life support device or system whose failure to perform can be reasonably expected to cause the failure of the life support device or system, or to affect its safety or effectiveness.

PRODUCT STATUS DEFINITIONS

Definition of Terms

Datasheet Identification	Product Status	Definition
Advance Information	Formative or In Design	This datasheet contains the design specifications for product development. Specifications may change in any manner without notice.
Preliminary	First Production	This datasheet contains preliminary data; supplementary data will be published at a later date. Fairchild Semiconductor reserves the right to make changes at any time without notice to improve design.
No Identification Needed	Full Production	This datasheet contains final specifications. Fairchild Semiconductor reserves the right to make changes at any time without notice to improve design.
Obsolete	Not In Production	This datasheet contains specifications on a product that has been discontinued by Fairchild semiconductor. The datasheet is printed for reference information only.