



PWM CONTROL 2A STEP-DOWN CONVERTER

FSP3130

FEATURES

- Input voltage: 3.6V to 18V.
- Output voltage: 0.8V to VCC.
- Duty ratio: 0% to 100% PWM control
- Oscillation frequency: 300KHz typ.
- Soft-start, Current limit, Enable function
- Thermal Shutdown function
- Built-in internal SW P-channel MOSFET
- SOP8L Package.

TYPICAL APPLICATION

- PC Motherboard
- LCD Monitor
- Graphic Card
- DVD-Video Player
- Telecom Equipment
- ADSL Modem
- Printer and other Peripheral Equipment
- Microprocessor core supply
- Networking power supply

PIN ASSIGNMENT

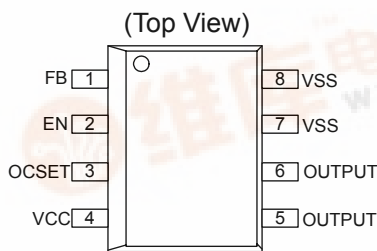

GENERAL DESCRIPTION

FSP3130 consists of step-down switching regulator with PWM control. These devices include a reference voltage source, oscillation circuit, error amplifier, internal PMOS and etc.

FSP3130 provides low-ripple power, high efficiency, and excellent transient characteristics. The PWM control circuit is able to vary the duty ratio linearly from 0 up to 100%. This converter also contains an error amplifier circuit as well as a soft-start circuit that prevents overshoot at startup. An enable function, an over current protect function and a short circuit protect function are built inside, and when OCP or SCP happens, the operation frequency will be reduced from 300KHz to 30KHz. Also, an internal compensation block is built in to minimum external component count.

With the addition of an internal P-channel Power MOS, a coil, capacitors, and a diode connected externally, these ICs can function as step-down switching regulators. They serve as ideal power supply units for portable devices when coupled with the SOP8L mini-package, providing such outstanding features as low current consumption. Since this converter can accommodate an input voltage up to 18V, it is also suitable for the operation via an AC adapter.

PIN DESCRIPTION

Pin Number	Pin Name	Pin Description
1	FB	Feedback Pin
2	EN	Power-off Pin H: Normal operation(Step-down operation) L: Step-down operation stopped(All circuits deactivated)
3	OCSET	Add an external resistor to set max output current
4	VCC	IC power supply pin
5,6	OUTPUT	Switch pin. Connect external inductor/diode here. Minimize trace area at this pin to reduce EMI.
7,8	VSS	GND pin

■ ABSOLUTE MAXIMUM RATINGS(NOTE)

Parameter	Value	Unit
VCC Pin Voltage, V_{CC}	$V_{SS}-0.3$ to $V_{SS}+20$	V
Feedback Pin Voltage, V_{FB}	$V_{SS}-0.3$ to V_{CC}	V
EN Pin Voltage, V_{EN}	$V_{SS}-0.3$ to $V_{IN} + 0.3$	V
Switch Pin Voltage, V_{OUTPUT}	$V_{SS}-0.3$ to $V_{IN} + 0.3$	V
Power Dissipation, P_D	Internally limited	mW
Operating Temperature Range, T_{OPR}	-20 to +125	°C
Storage Temperature Range, T_{STG}	-40 to +150	°C

Note: Do not exceed these limits to prevent damage to the device. Exposure to absolute maximum rating conditions for long periods may affect device reliability.

■ ELECTRICAL CHARACTERISTICS

($V_{IN} = 12V$, $T_A = 25^\circ C$, unless otherwise specified.)

Parameter	Symbol	Test Conditions	Min.	Typ.	Max.	Unit
Input Voltage	V_{IN}		3.6		18	V
Feedback Voltage	V_{FB}	$I_{IOUT} = 0.1A$	0.784	0.8	0.816	V
Feedback Bias Current	I_{FB}	$I_{IOUT} = 0.1A$		0.1	0.5	μA
Switch Current	I_{SW}		2.5			A
Current Consumption During Power Off	I_{SSS}	$V_{EN} = 0$		10		μA
Line Regulation	$\Delta V_{OUT} / V_{OUT}$	$V_{IN} = 5V \sim 18V$		1	2	%
Load Regulation	$\Delta V_{OUT} / V_{OUT}$	$I_{IOUT} = 0.1A \sim 2A$		0.2	0.5	%
Oscillation Frequency	fosc	Measure waveform at SW pin	240	300	360	KHz
Frequency of Current Limit or Short Circuit Protect	fosc1	Measure waveform at SW pin	10			KHz
Enable Pin Input Voltage	V_{SH}	Evaluate oscillation at SW pin	2.0			V
	V_{SL}	Evaluate oscillation stop at SW pin			0.8	
Enable Pin Input Leakage Current	I_{SH}			20		μA
	I_{SL}			-10		
OCSET Pin Bias Current	I_{OCSET}		75	90	105	μA
Soft-Start Time	T_{SS}		0.3	2	5	ms
Internal MOSFET R_{dson}	R_{dson}	$V_{IN} = 5V, V_{FB} = 0$		110	150	m Ω
		$V_{IN} = 12V, V_{FB} = 0$		70	100	
Efficiency	EFFI	$V_{IN} = 12V, V_{OUT} = 5V,$ $I_{IOUT} = 2A$		92		%
Thermal Resistance Junction to Ambient	θ_{JA}			65		°C/W

■ FUNCTIONAL BLOCK DIAGRAM

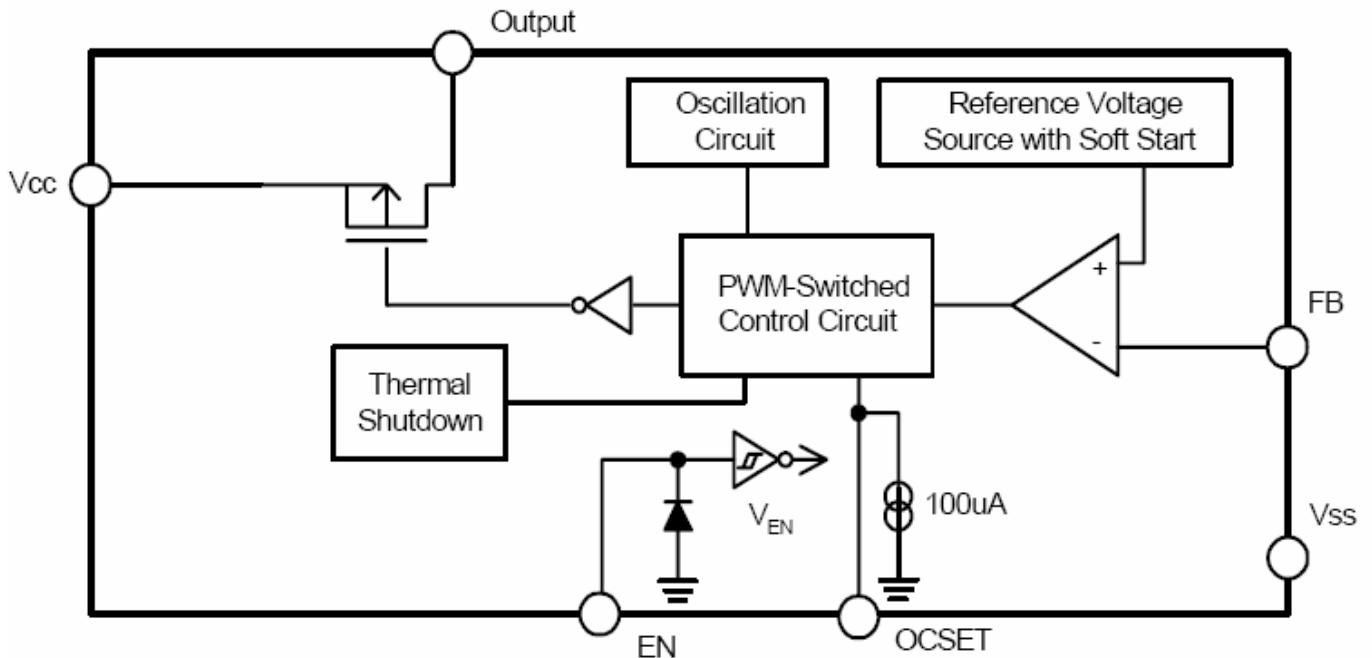

■ FUNCTIONAL DESCRIPTION

PWM Control

The FSP3130 consists of DC/DC converters that employ a pulse-width modulation (PWM) system. In converters of the FSP3130, the pulse width varies in a range from 0 to 100%, according to the load current. The ripple voltage produced by the switching can easily be removed through a filter because the switching frequency remains constant. Therefore, these converters provide a low-ripple power over broad ranges of input voltage and load current.

Under Voltage Lockout

The under voltage lockout circuit of the FSP3130 assures that the high-side MOSFET driver outputs remain in the off state whenever the supply voltage drops below 3.3V. Normal operation resumes once VCC rises above 3.5V.

R_{DS(ON)} Current Limiting

The current limit threshold is setting by the external resistor connecting from VCC supply to OCSET. The internal 100uA sink current crossing the resistor sets the voltage at the pin of OCSET. When the PWM voltage is less than the voltage at OCSET, an over-current condition is triggered.

$$I_{LOAD} \times R_{DS(ON)} = I_{OCSET} \times R_{OCSET}$$

See above formula for setting the current limit value

■ TYPICAL APPLICATION CIRCUIT

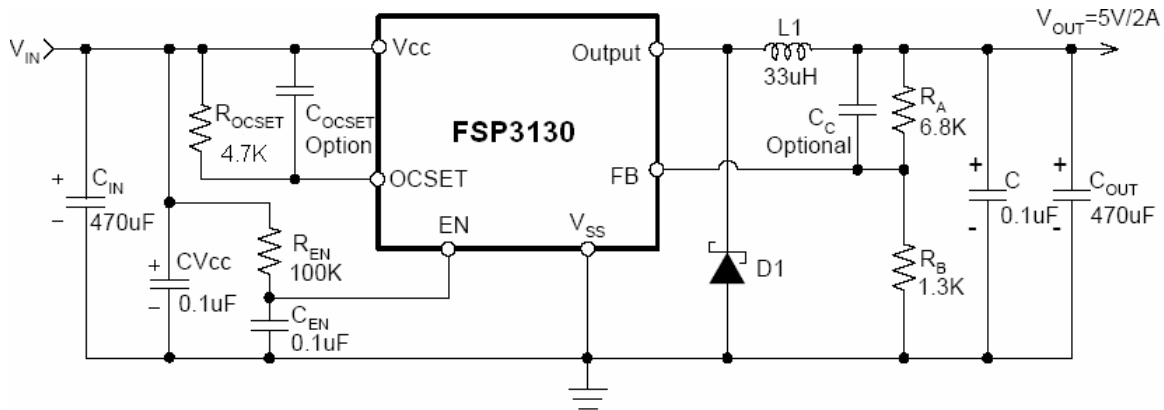

Note: $V_{OUT} = V_{FB} * (1 + R_A/R_B)$
 $R_B = 0.7K\Omega \sim 5K\Omega$

$V_{IN} = 12V, I_{MAX} = 2A$			
V_{OUT}	2.5V	3.3V	5V
L1 Value	22uH	27uH	33uH

■ TEST CIRCUITS

1) Enable Function Test

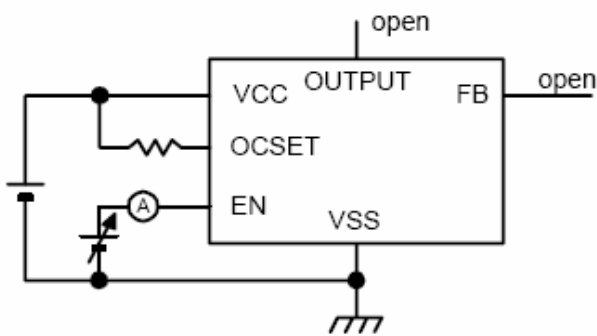

2) Feedback Function Test

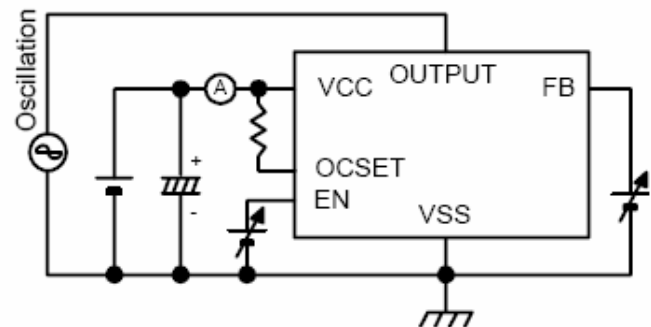

3) Operation Function Test

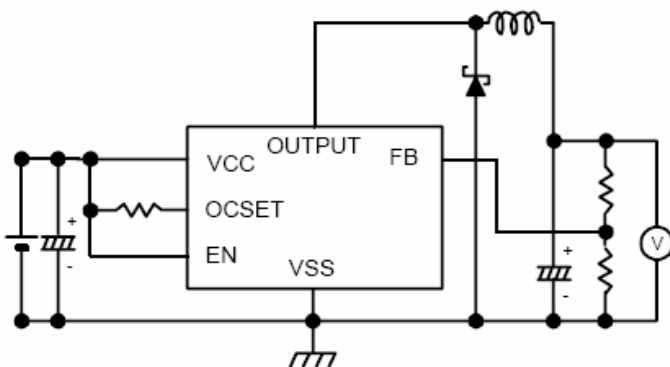

■ TYPICAL CHARACTERISTICS

FSP3130 Vin v.s. Frequency
(Vout=3.3V; Iout=0.2A)

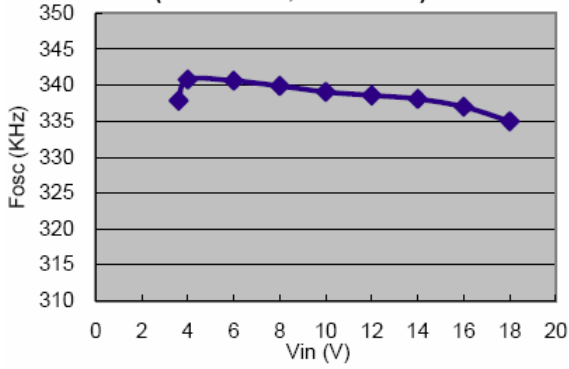

FSP3130 Vin v.s. FB
(Vout=3.3V; Iout=0.2A)

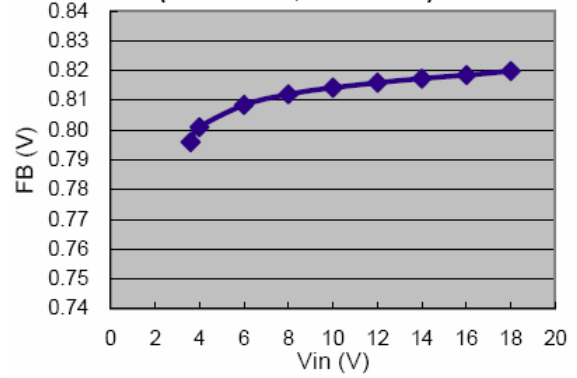

FSP3130 Line Regulation
(Vout=3.3V; Iout=0.2A)

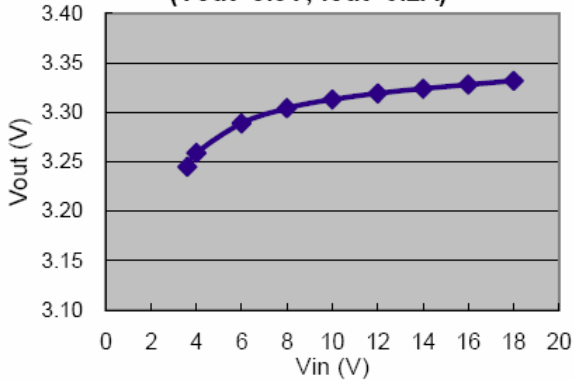

FSP3130 Load Regulation
(Vin=12V)

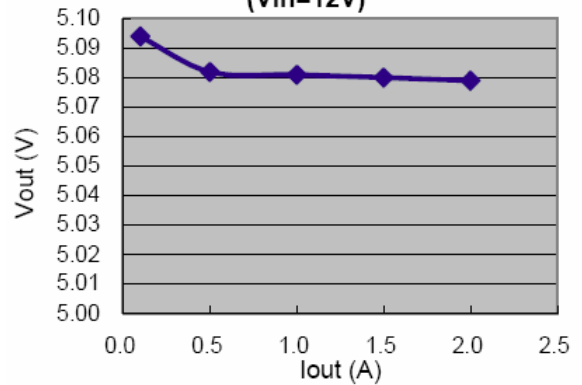

FSP3130 Efficiency

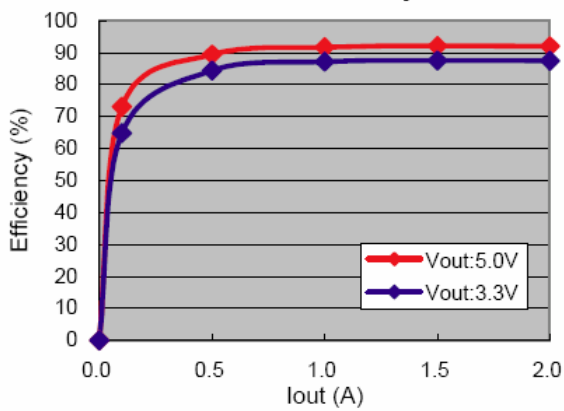

■ TYPICAL CHARACTERISTICS (CONTINUED)

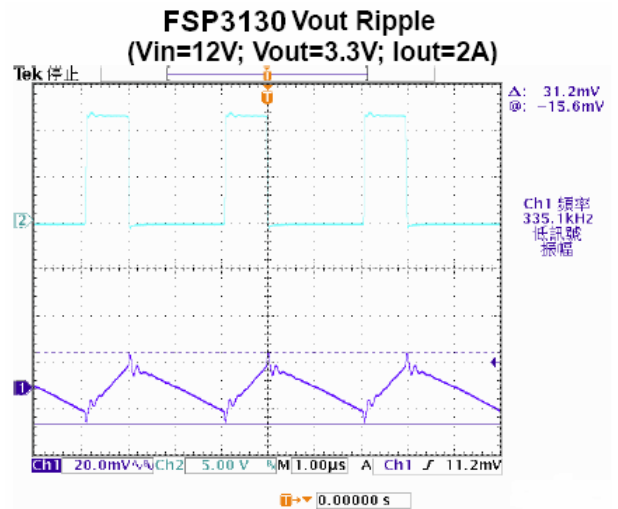
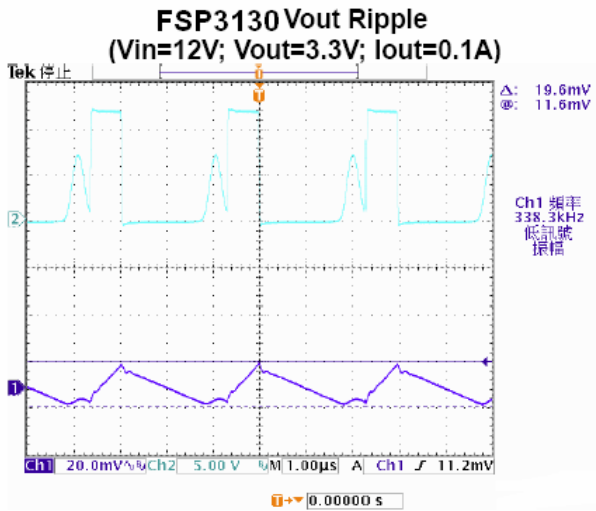

■ ORDER INFORMATION

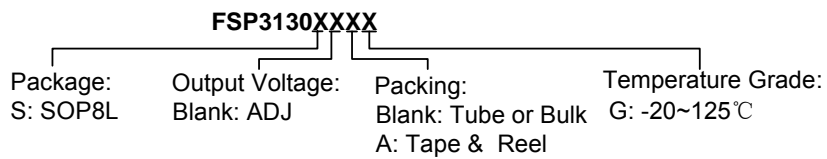

■ MARKING INFORMATION

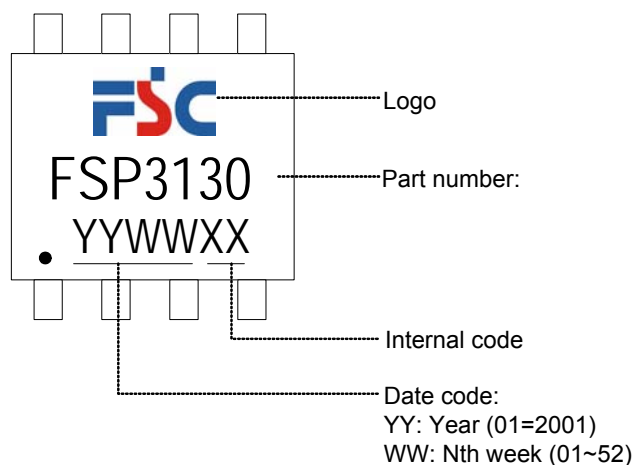

■ PACKAGE INFORMATION

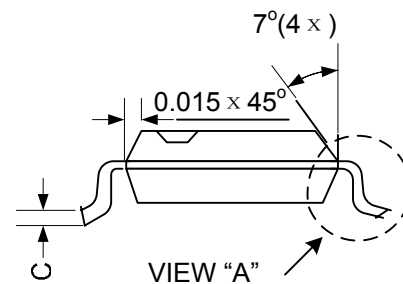
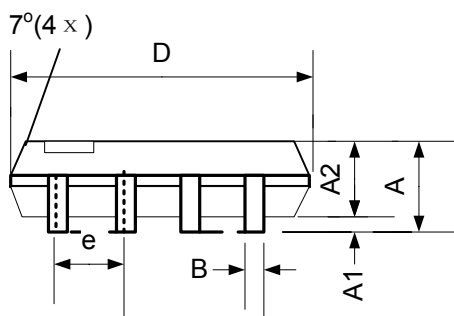
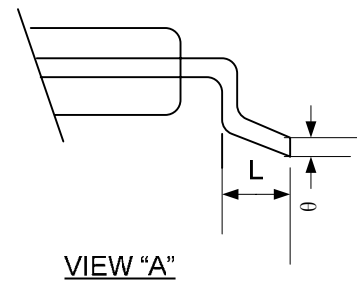
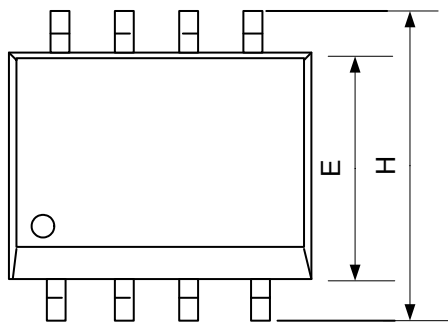

Symbol	Dimensions In Millimeters			Dimensions In Inches		
	Min.	Nom.	Max.	Min.	Nom.	Max.
A	1.40	1.60	1.75	0.055	0.063	0.069
A1	0.10		0.25	0.004		0.010
A2	1.30	1.45	1.50	0.051	0.057	0.059
B	0.33	0.41	0.51	0.013	0.016	0.020
C	0.19	0.20	0.25	0.0075	0.008	0.010
D	4.80	5.05	5.30	0.189	0.199	0.209
E	3.70	3.90	4.10	0.146	0.154	0.161
e	1.27TYP.			0.050TYP.		
H	5.80	5.99	6.20	0.228	0.236	0.244
L	0.38	0.71	1.27	0.015	0.028	0.050
θ	0°		8°	0°		8°