



350 MA CONSTANT-CURRENT LED DRIVER

FSP3300

FEATURES

- No external component required
- 350mA constant sink current
- Output short circuit protection
- Low dropout voltage
- Low quiescent current
- Build-in thermal protection
- Supply voltage range 2.7V~7V
- 2KV HBM ESD protection
- Advanced CMOS process
- SOT89 and TO252 package

PIN CONFIGURATION

(1) SOT89

(Top View)

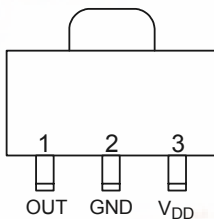

GENERAL DESCRIPTION

The FSP3300 is a low dropout current regulator rated for 350mA constant sink current. The low quiescent current and low dropout voltage is achieved by advanced CMOS process

APPLICATIONS

- Power LED driver

(2) TO252

(Top View)

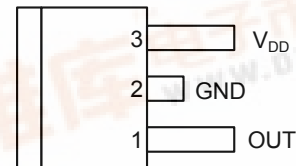

Symbol	Name	Descriptions
1	OUT	Output pin, connect to load
2	GND	Ground
3	V _{DD}	Power supply

BLOCK DIAGRAM

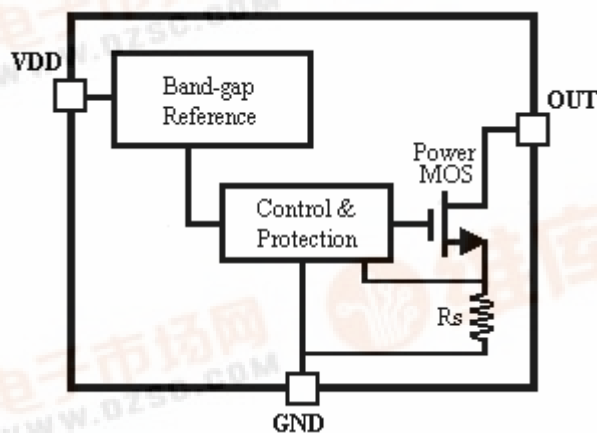

■ ABSOLUTE MAXIMUM RATINGS

Symbol	Parameter	Rating	Unit
V_{DD}	Input Voltage	2.7 to 7	V
V_{LEDn}	Output Voltage	2.7 to 7	V
T_J	Maximum Junction Temperature	150	°C
Tstg	Storage Temperature Range	-40~+150	°C

Note: Exceeding these ratings could cause damage to the device. All voltages are with respect to Ground.
Currents are positive into, negative out of the specified terminal.

■ ELECTRICAL CHARACTERISTICS ($V_{DD}=3.7V$, $T_A=25^\circ C$, UNLESS OTHERWISE NOTED)

Symbol	Parameter	Test Conditions	Min.	Typ.	Max.	Unit	Apply Pin
I_{SINK}	Output Sink Current	$V_{OUT}=0.2V$	305	350	390	mA	OUT
	Load Regulation	$V_{OUT}=0.2V$ to 3V			5	mA/V	
	Line Regulation	$V_{DD}=3V$ to 6V, $V_{OUT}=0.2V$			5	mA/V	
V_{OUTL}	Output Dropout Voltage			120		mV	
I_{DD}	Supply Current Consumption			200		μA	V_{DD}

Note: Output dropout voltage: $90\% \times I_{OUT} @ V_{OUT}=200mV$

■ Recommended Operating Conditions

Symbol	Parameter	Min.	Typ.	Max.	Unit
V_{DD}	Supply Voltage	2.7		6	V
I_{OUT}	Output Sink Current			400	mA
T_a	Operating free-air temperature range	-40		+85	°C

■ Power Dissipation Table

Package	θ_{JA} (°C/W)	Derating factor (mW/°C)		Power rating (mW)	Power rating (mW)	Power rating (mW)
		$T_A \geq 25^\circ C$	$T_A \leq 25^\circ C$	$T_A = 70^\circ C$	$T_A = 85^\circ C$	
PK	71	14.1	1763	1128	916	

Note: Junction Temperature Calculation: $T_J = T_A + (P_D \times \theta_{JA})$.

P_D : Power Dissipation, T_A : Ambient temperature, θ_{JA} : Thermal Resistance-Junction to Ambient.

The θ_{JA} numbers are guidelines for the thermal performance of the device/PC-board system.

All of the above assume no ambient airflow.

■ TYPICAL APPLICATIONS CIRCUIT

(1) Typical Application Circuit

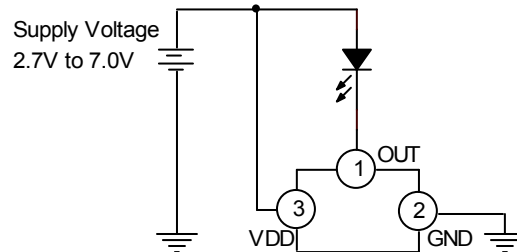

Note:

1. The supply voltage should be larger than the forward voltage of the LED by 0.15V.

$$V_{DD} \geq V_{LEDF} + 0.15$$

In the application of $V_{DD} = V_{LEDF} + 0.15$, the chip works in the max efficiency and min power dissipation

(2) Typical Application Circuit for Larger Current

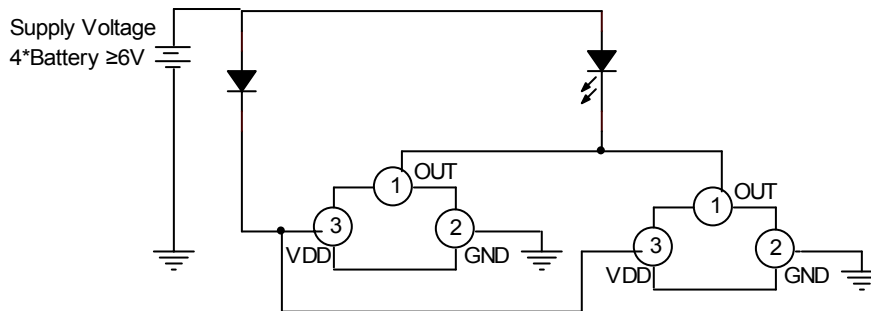

Note:

The FSP3300 can be parallel connected to get larger driver current (about 700mA) for 3W LED.

At this application, the supply voltage should be 6V at least for 3W LED. To minimize the chip power dissipation, there should be a diode connected between supply to V_{DD} of the chip. The forward voltage of the diode should be less than 3.3V.

■ APPLICATION INFORMATION

The maximum power dissipation on regulator:

$$P_{D(MAX)} = V_{OUT(MAX)} \times I_{OUT(NOM)} + V_{IN(MAX)} \times I_Q$$

$V_{OUT(MAX)}$ = the maximum voltage on output pin

$I_{OUT(NOM)}$ = the nominal output current

I_Q = the quiescent current the regulator consumes at

$V_{IN(MAX)}$ = the maximum input voltage

Thermal consideration:

The FSP3300 have internal power and thermal limiting circuitry designed to protect the device under overload conditions. However maximum junction temperature ratings should not be exceeded under continuous normal load conditions. The thermal protection circuit of FSP3300 prevents the device from damage due to excessive power dissipation. When the device temperature rises to approximately 120°C, the regulator will be turned off. When power consumption is over about 700mW (SOT89-3L package at $T_A = 70^\circ\text{C}$), additional heat sink is required to control the junction temperature below 120°C.

$$\text{The junction temperature is: } T_J = P_D(\theta_{JT} + \theta_{CS} + \theta_{SA}) + T_A$$

P_D : Dissipation power

θ_{JT} : Thermal resistance from the junction to the mounting tab of the package

θ_{CS} : Thermal resistance through the interface between the IC and the surface on which it is mounted.

(typically, $\theta_{CS} \leq 1.0^\circ\text{C/W}$)

FSP3300

θ_{SA} : Thermal resistance from the mounting surface to ambient (thermal resistance of the heat sink)
 If PC Board copper is going to be used as a heat sink, below table can be used to determine the appropriate size of copper foil required. For multi-layered PCB, these layers can also be used as a heat sink, They can be connected with several through hole vias.

PCB θ_{SA} ($^{\circ}\text{C}/\text{W}$)	59	45	38	33	27	24	21
PCB heat sink size (mm^2)	500	1000	1500	2000	3000	4000	5000

■ TYPICAL PERFORMANCE CHARACTERISTICS

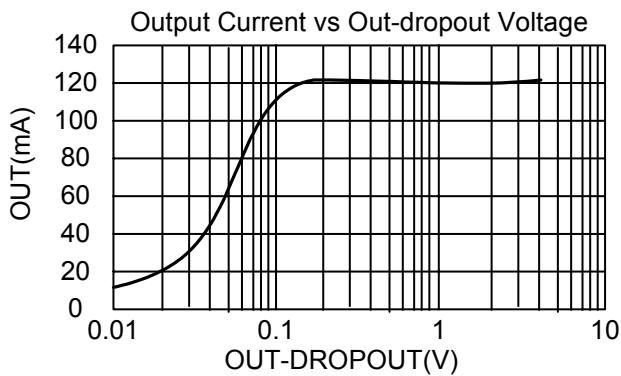
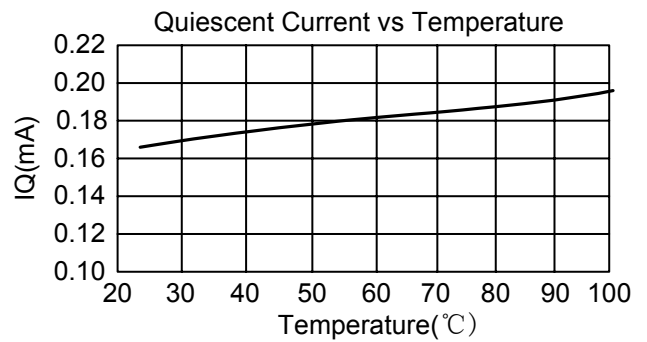
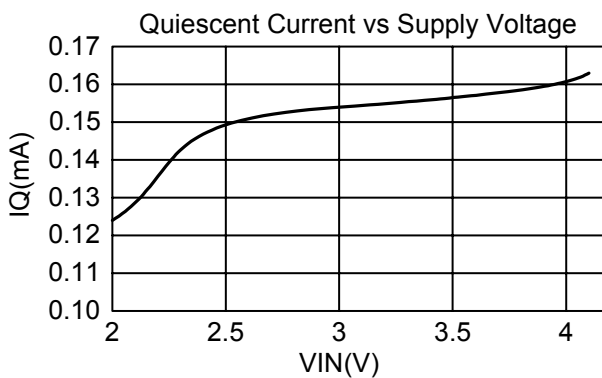

■ ORDERING INFORMATION

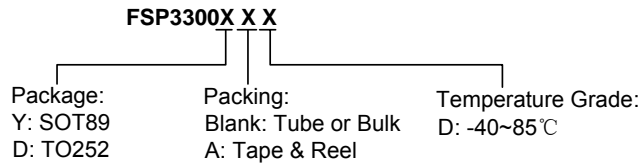

■ MARKING INFORMATION

(1) SOT89

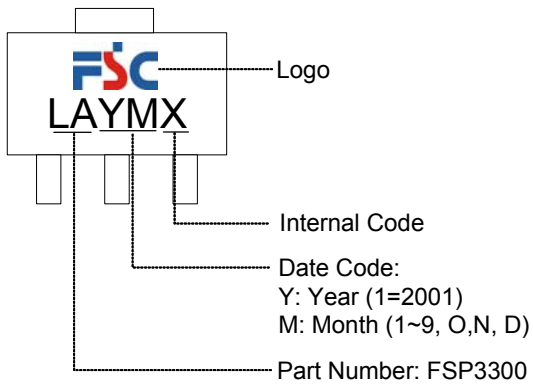

(2) TO252

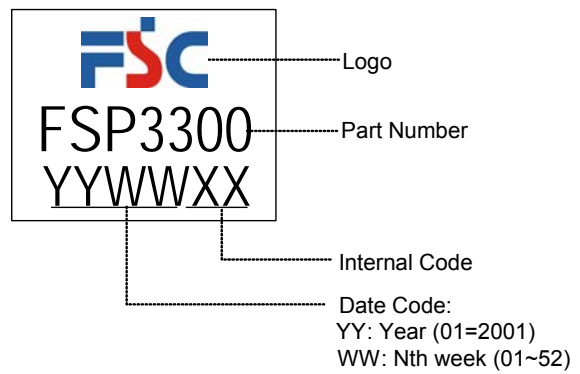

■ PACKAGE INFORMATION

(1) SOT89

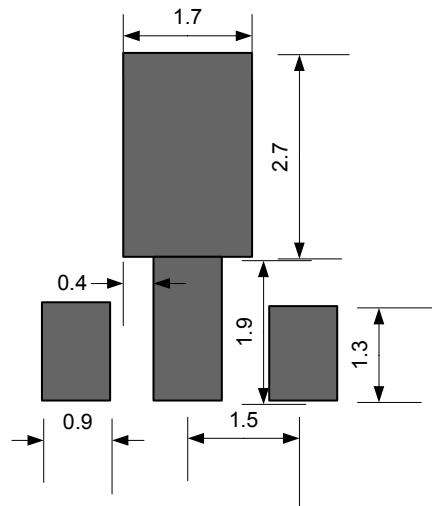
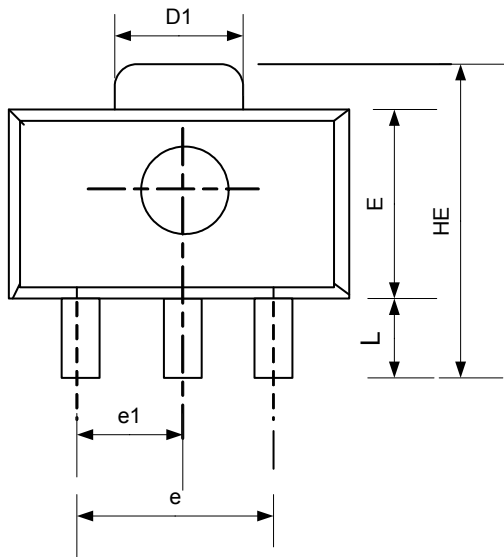

Land Patten Recommendation (Unit :mm)

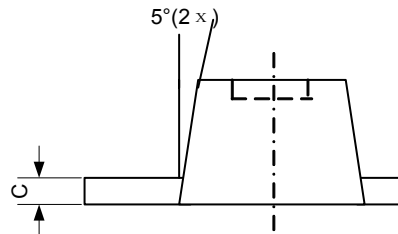
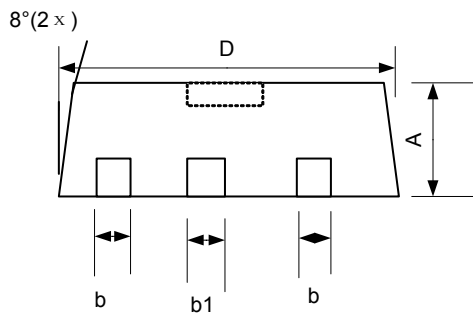

Symbol	Dimensions In Millimeters			Dimensions In Inches		
	Min.	Nom.	Max.	Min.	Nom.	Max.
A	1.40	1.50	1.60	0.055	0.059	0.063
b	0.36	0.42	0.48	0.014	0.016	0.018
b1	0.41	0.47	0.53	0.016	0.043	0.051
C	0.35	0.39	0.43	0.014	0.015	0.017
D	4.40	4.50	4.60	0.173	0.177	0.181
D1	1.40	1.60	1.75	0.055	0.062	0.069
e	2.90	3.00	3.10	0.114	0.118	0.122
e1	1.45	1.50	1.55	0.057	0.059	0.061
E	2.35	2.48	2.60	0.093	0.098	0.102
HE	3.94		4.25	0.155		0.167
L	0.80		1.20	0.031		0.047

(2) TO252

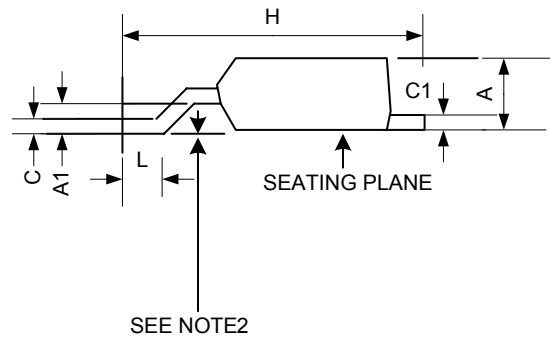
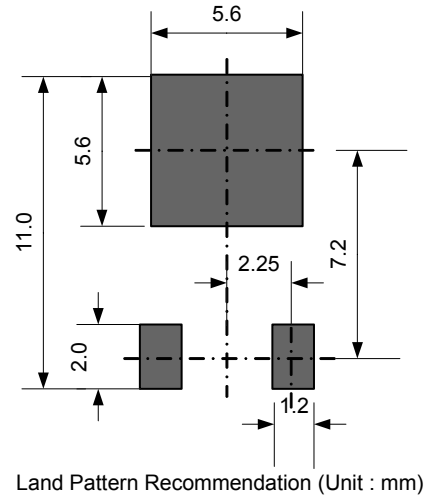
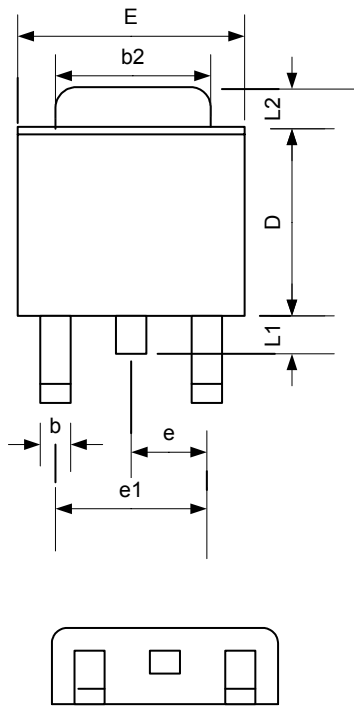

Notes:

1. JEDEC Outline:TO-252 AB
2. Mils suggested for positive contact at mounting

Symbol	Dimensions In Millimeters			Dimensions In Inches		
	Min.	Nom.	Max.	Min.	Nom.	Max.
A	2.18	2.29	2.39	0.086	0.090	0.094
A1	1.02	1.15	1.27	0.040	0.045	0.050
b	0.61TYP.			0.024TYP.		
b2	5.20	5.35	5.50	0.205	0.211	0.217
C	0.46	0.52	0.58	0.018	0.020	0.023
C1	0.46	0.52	0.58	0.018	0.020	0.023
D	5.33	5.57	5.80	0.210	0.219	0.228
E	6.35	6.58	6.80	0.250	0.259	0.268
e	2.25BSC.			0.089BSC.		
e1	4.50BSC.			0.177BSC.		
H	9.00	9.70	10.40	0.354	0.382	0.409
L	0.51			0.020		
L1	0.64	0.83	1.02	0.025	0.033	0.040
L2	1.52	1.78	2.03	0.060	0.070	0.080