



September 2008

# FSQ500L

## Compact, Green Mode, Fairchild Power Switch (FPS™)

### Features

- Single Chip 700V SenseFET Power Switch
- Precision Fixed Operating Frequency: 130kHz
- No-load consumption 250mW at 265V<sub>AC</sub> with Burst Mode and Down to 60mW with External Bias
- Internal Startup Switch
- Soft-Start Time Tuned by External Capacitor
- Under-Voltage Lockout (UVLO) with Hysteresis
- Pulse-by-Pulse Current Limit
- Overload Protection (OLP) and Internal Thermal Shutdown Function (TSD) with Hysteresis
- Auto-Restart Mode
- No Need for Auxiliary Bias Winding

### Description

The FSQ500L is specially designed for a replacement of linear power supplies with low cost. This device combines current-mode Pulse Width Modulator (PWM) with a senseFET. The integrated PWM controller features include: a fixed oscillator, Under Voltage Lockout (UVLO) protection, Overload Protection (OLP), Leading-Edge Blanking (LEB), an optimized gate turn-on/turn-off driver, Thermal Shutdown (TSD) protection with hysteresis, and temperature-compensated precision-current sources for loop compensation. When compared to a linear power supply, the FSQ500L device reduces total size and weight, while increasing efficiency, productivity, and system reliability. This device provides a basic platform for cost-effective flyback converters.



### Applications

- Cost-Effective Linear Power Supplies Replacement
- Charger and Adapter for Mobile Phone, PDA, MP3, and Cordless Phone

### Related Application Notes

- [AN-4137, AN-4141, AN-4147 \(Flyback\)](#)
- [AN-4138 \(Charger\)](#)

Maximum Output Power <sup>(1)</sup>			
230Vac ± 15% <sup>(2)</sup>		85-265V <sub>AC</sub>	
Adapter <sup>(3)</sup>	Open Frame <sup>(4)</sup>	Adapter <sup>(3)</sup>	Open Frame <sup>(4)</sup>
2.5W	3.0W	2.0W	2.5W

#### Notes:

1. The junction temperature can limit the maximum output power.
2. 230V<sub>AC</sub> or 100/115V<sub>AC</sub> with doubler.
3. Typical continuous power in a non-ventilated enclosed adapter measured at 50°C ambient.
4. Maximum practical continuous power in an open frame design at 50°C ambient.

### Ordering Information

Part Number	Operating Temperature Range	Eco Status	Package	Packing Method
FSQ500L	-25°C to +85°C	RoHS	4-Lead, Small Outline Package (SOT223-4L)	Tape & Reel

For Fairchild's definition of "green" Eco Status, please visit: [http://www.fairchildsemi.com/company/green/rohs\\_green.html](http://www.fairchildsemi.com/company/green/rohs_green.html).

FSQ500L — Compact, Green Mode, Fairchild Power Switch (FPS™)

### Application Circuit Diagram

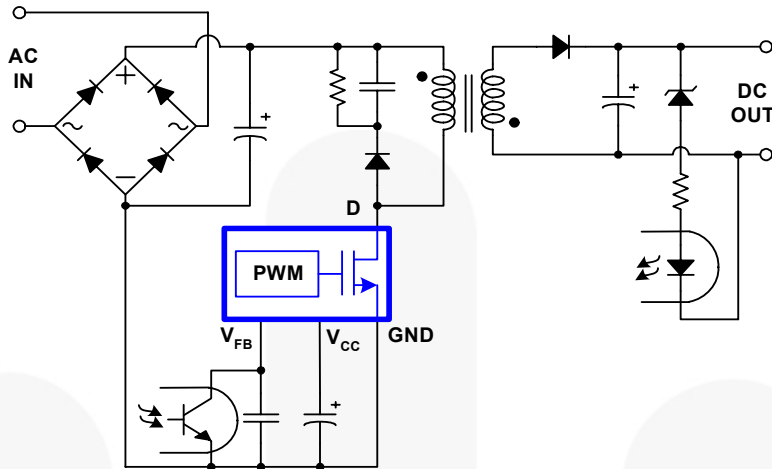

Figure 1. Typical Application Circuit

### Internal Block Diagram

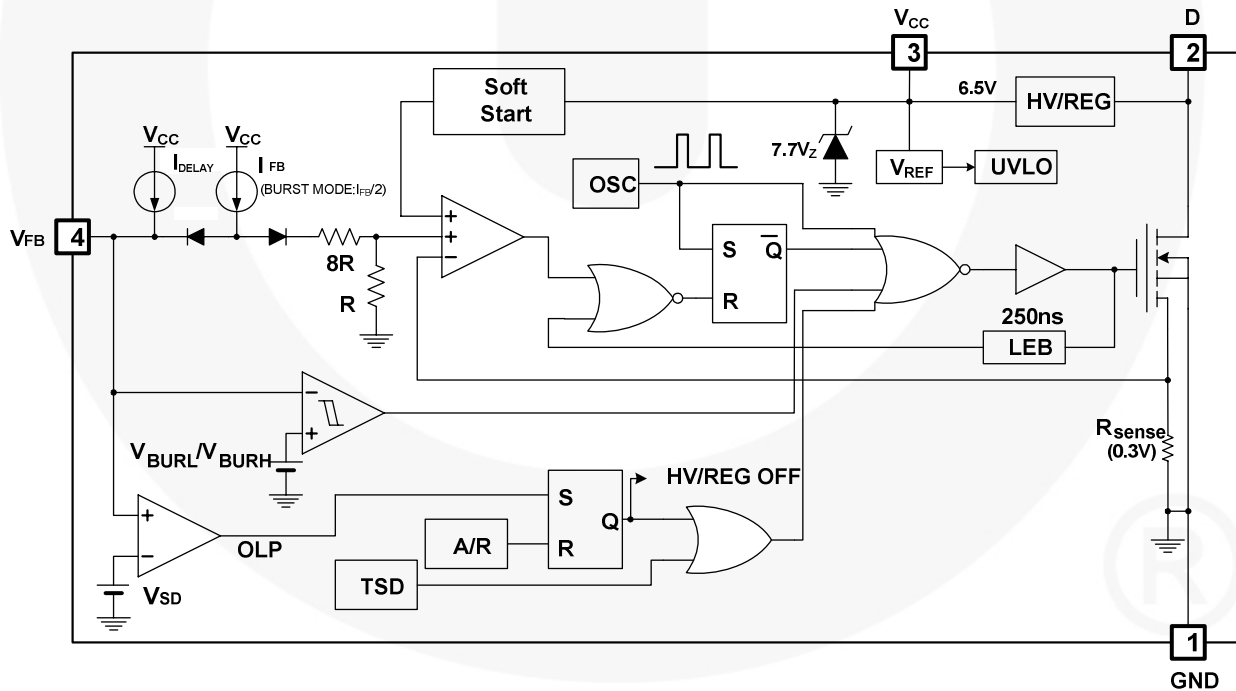

Figure 2. Internal Block Diagram

## Pin Assignments

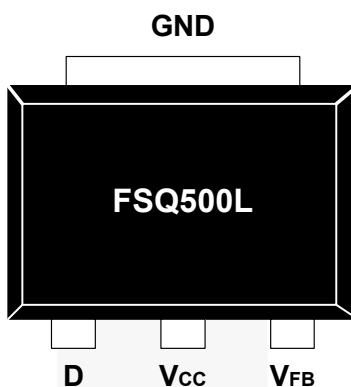

Figure 3. Package / Pin Diagram

## Pin Definitions

Pin #	Name	Description
1	GND	This pin is the control ground and the senseFET source.
2	D	High-voltage power senseFET drain connection. In addition, at startup, the internal high-voltage current source supplies internal bias and charges the external capacitor connected to the $V_{CC}$ pin. Once $V_{CC}$ reaches 6.0V, all internal blocks are activated. The internal high-voltage current source is alive until $V_{CC}$ reaches 6.5V. After that, the internal high voltage current source turns on and off irregularly to maintain $V_{CC}$ at 6.5V.
3	$V_{CC}$	This pin is connected to a storage capacitor. A high-voltage regulator connected between pin 2 (D) and this pin provides the supply voltage to the FSQ500L at startup and when switching during normal operation. The FSQ500L eliminates the need for auxiliary bias winding and associated external components.
4	$V_{FB}$	This pin is internally connected to the non-inverting input of the PWM comparator. The collector of an opto-coupler is typically tied to this pin. For stable operation, a capacitor should be placed between this pin and GND. If the voltage of this pin reaches 4.5V, the overload protection triggers, which shuts down the FPS.

## Absolute Maximum Ratings

The “Absolute Maximum Ratings” are those values beyond which the safety of the device cannot be guaranteed. The device should not be operated at these limits. The parametric values defined in the Electrical Characteristics tables are not guaranteed at the absolute maximum ratings. The “Recommended Operating Conditions” table defines the conditions for actual device operation.

Symbol	Parameter	Min.	Max.	Unit
$V_{DS}$	Drain Pin Voltage <sup>(5)</sup>	700		V
$V_{CC}$	Supply Voltage		10	V
$V_{FB}$	Feedback Voltage Range	-0.3	$V_{CC}$	V
$P_D$	Total Power Dissipation		0.78	W
$I_{DM}$	Drain Current Pulsed <sup>(6)</sup>		0.41	A
$T_J$	Operating Junction Temperature	-25	+150	°C
$T_{STG}$	Storage Temperature	-55	+150	°C

### Notes:

5. LDMOS available drain voltage is -0.3V ~ 700V.
6. Repetitive rating: pulse width is limited by maximum junction temperature.

## Thermal Impedance

Symbol	Parameter	Value	Unit
$\theta_{JA}$	Junction-to-Ambient Thermal Resistance <sup>(7)</sup>	+160	°C/W

### Note:

7. Free-standing with no heat sink; minimum land pattern.

## Electrical Characteristics

$T_J = 25^\circ\text{C}$  unless otherwise specified.

Symbol	Parameter	Test Conditions	Min.	Typ.	Max.	Unit
<b>SenseFET Section</b>						
$BV_{DSS}$	Drain-Source Breakdown Voltage	$V_{CC} = 6.5\text{V}, V_{FB} = 0\text{V}, I_D = 150\mu\text{A}$	700			V
$I_{DSS}$	Zero-Gate-Voltage Drain Current	$V_{CC} = 6.5\text{V}, V_{FB} = 0\text{V}, V_{DS} = 560\text{V}$			150	$\mu\text{A}$
$R_{DS(ON)}$	Drain-Source On-State Resistance	$T_J = 25^\circ\text{C}, I_D = 25\text{mA}$		25	29	$\Omega$
		$T_J = 100^\circ\text{C}, I_D = 25\text{mA}$		35	41	$\Omega$
$C_{ISS}$	Input Capacitance <sup>(8)</sup>	$V_{GS} = 6.5\text{V}$		42		pF
$C_{OSS}$	Output Capacitance <sup>(8)</sup>	$V_{DS} = 40\text{V}, f_s = 1\text{MHz}$		25		pF
$t_r$	Rise Time <sup>(8)</sup>	$V_{DS} = 350\text{V}, I_D = 25\text{mA}$		100		ns
$t_f$	Fall Time <sup>(8)</sup>	$V_{DS} = 350\text{V}, I_D = 25\text{mA}$		50		ns
<b>Control Section</b>						
$f_s$	Switching Frequency	$V_{CC} = 6.5\text{V}, V_{FB} = 1.0\text{V}$	120	130	140	kHz
$\Delta f_s$	Switching Frequency Variation <sup>(8)</sup>	$-25^\circ\text{C} < T_J < 125^\circ\text{C}$		$\pm 5$	$\pm 7$	%
$I_{FB(Burst)}$	Feedback Source Current	$V_{CC} = 6.5\text{V}, V_{FB} = 0\text{V}$	98	110	122	$\mu\text{A}$
$I_{FB(Normal)}$		$V_{CC} = 6.5\text{V}$	200	225	250	$\mu\text{A}$
$D_{MAX}$	Maximum Duty Ratio	$V_{CC} = 6.5\text{V}, V_{FB} = 4.0\text{V}$	54	60	66	%
$D_{MIN}$	Minimum Duty Ratio	$V_{CC} = 6.5\text{V}, V_{FB} = 0\text{V}$			0	%
$V_{START}$	UVLO Threshold Voltage	$V_{FB} = 0\text{V}, V_{CC}$ Sweep	5.5	6.0	6.5	V
$V_{STOP}$		After Turn-on, $V_{FB} = 0\text{V}, V_{CC}$ Sweep	4.5	5.0	5.5	V
$V_{DLY\_EN}$	Shutdown Delay Current Enable Voltage	$V_{FB} = V_{SD}, V_{CC}$ Sweep from 6V	6.0	6.5	7.0	V
<b>Burst-Mode Section</b>						
$V_{BURH}$	Burst Mode Voltage	$V_{CC} = 6.5\text{V}, V_{FB}$ Sweep	0.75	0.80	0.85	V
$V_{BURL}$			0.70	0.75	0.80	V
HYS			30	50	80	mV
<b>Protection Section</b>						
$I_{LIM}$	Peak Current Limit	$di/dt = 150\text{mA}/\mu\text{s}$	245	280	315	mA
$V_{SD}$	Shutdown Feedback Voltage	$V_{CC} = 6.5\text{V}, V_{FB}$ Sweep	4.1	4.5	4.9	V
$I_{DELAY}$	Shutdown Delay Current	$V_{CC} = 6.5\text{V}, V_{FB} = 4.0\text{V}$	4	5	6	$\mu\text{A}$
$t_{LEB}$	Leading Edge Blanking Time <sup>(8)</sup>			250		ns
$t_{CLD}$	Current Limit Delay Time <sup>(8)</sup>			100		ns
TDS	Thermal Shutdown Temperature <sup>(8)</sup>		130	140	150	$^\circ\text{C}$
HYS				80		$^\circ\text{C}$
<b>Total Device Section</b>						
$I_{OP-BURST}$	Operating Supply Current (Control Part Only)	$V_{CC} = 6.5\text{V}, V_{FB} = 0\text{V}$	360	430	500	$\mu\text{A}$
$I_{OP-FB}$		$V_{CC} = 6.5\text{V}, V_{FB} = 4\text{V}$	640	760	880	$\mu\text{A}$
$I_{CH}$	Startup Charging Current	$V_{CC} = V_{FB} = 0\text{V}, V_{DS} = 40\text{V}$	3.3			mA
$V_{CCREG}$	Supply Shunt Regulator	$V_{DS} = 40\text{V}, V_{FB} = 0\text{V}$	6.0	6.5	7.0	V
$V_{CCREG\_TSD}$	Supply Shunt Regulator During TSD <sup>(8)</sup>		5.2	5.7	6.2	V

### Note:

8. These parameters, although guaranteed, are not 100% tested in production.

## Typical Performance Characteristics

These characteristic graphs are measured at  $T_A = 25^\circ\text{C}$ .

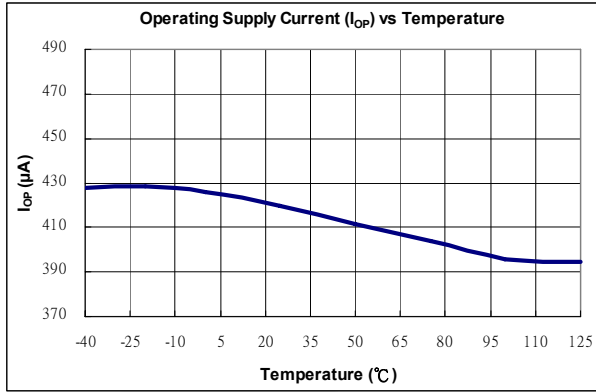

**Figure 4. Operating Supply Current ( $I_{OP\_Burst}$ ) vs. Temperature**

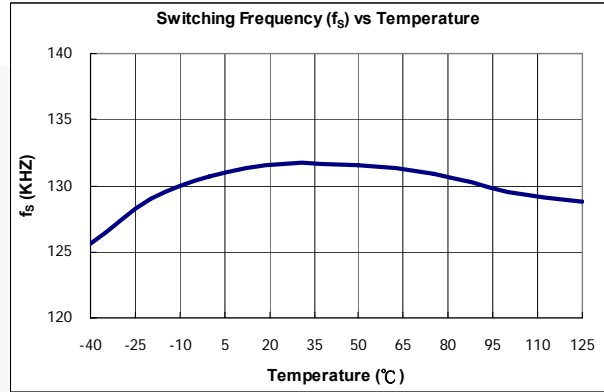

**Figure 5. Switching Frequency ( $f_s$ ) vs. Temperature**

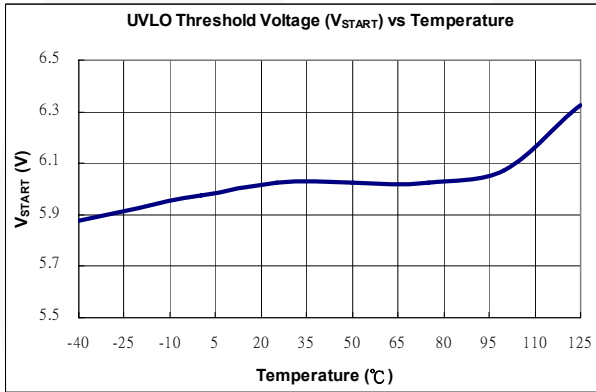

**Figure 6. UVLO Threshold Voltage ( $V_{START}$ ) vs. Temperature**

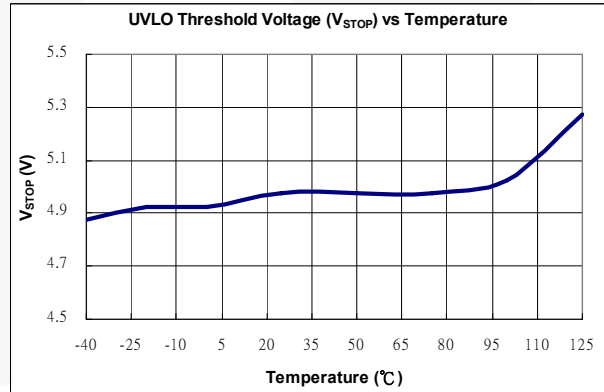

**Figure 7. UVLO Threshold Voltage ( $V_{STOP}$ ) vs. Temperature**

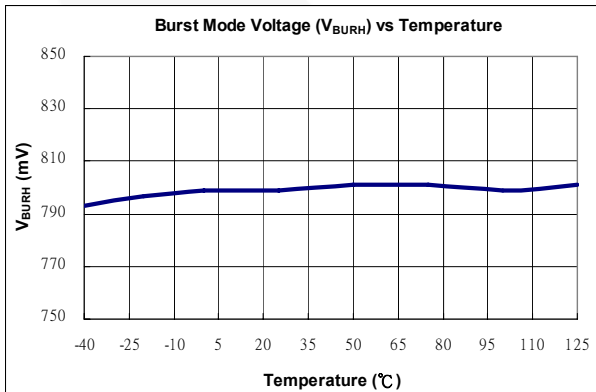

**Figure 8. Burst-Mode Voltage ( $V_{BURH}$ ) vs. Temperature**

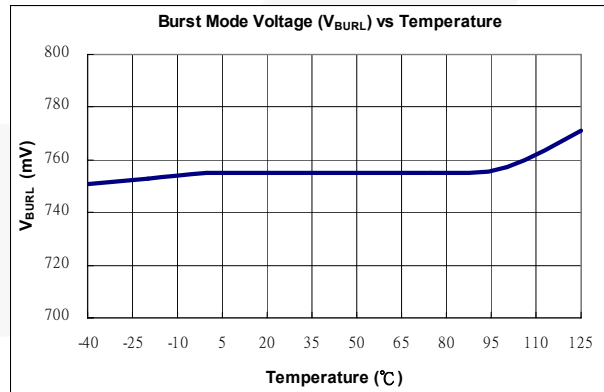

**Figure 9. Burst-Mode Voltage ( $V_{BURL}$ ) vs. Temperature**

## Typical Performance Characteristics (Continued)

These characteristic graphs are measured at  $T_A = 25^\circ\text{C}$ .

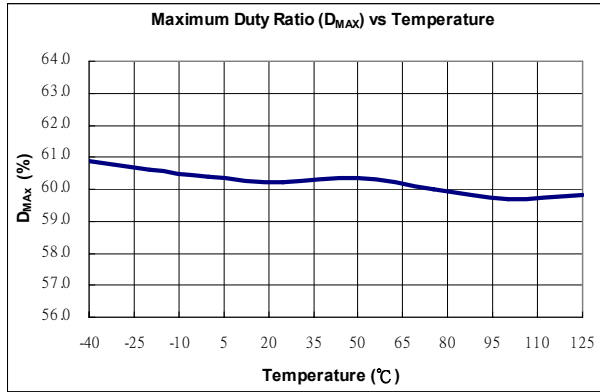

Figure 10. Maximum Duty Ratio ( $D_{MAX}$ ) vs. Temperature

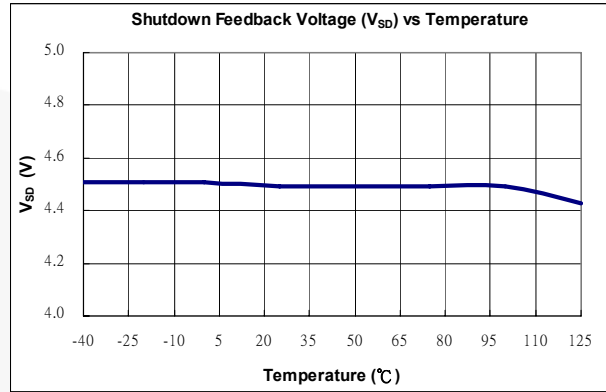

Figure 11. Shutdown Feedback Voltage ( $V_{SD}$ ) vs. Temperature

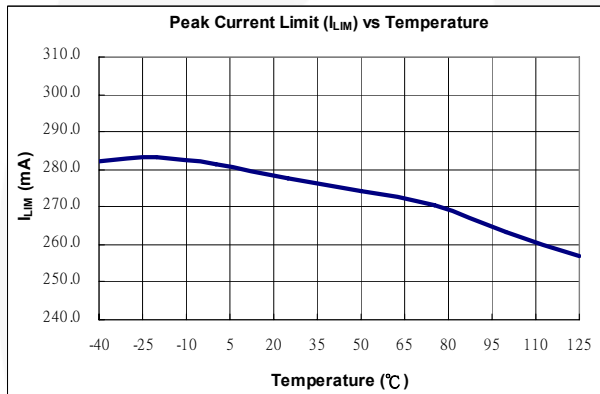

Figure 12. Peak Current Limit ( $I_{LIM}$ ) vs. Temperature

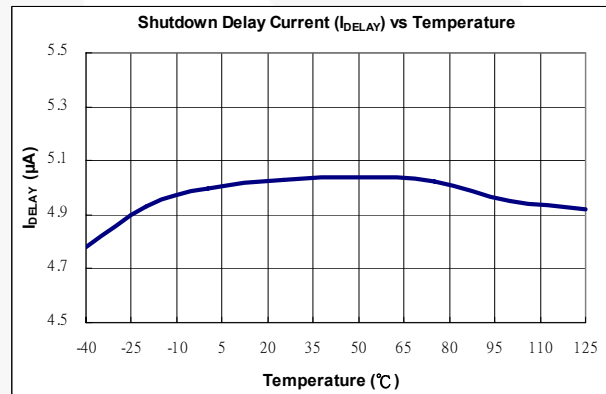

Figure 13. Shutdown Delay Current ( $I_{DELAY}$ ) vs. Temperature

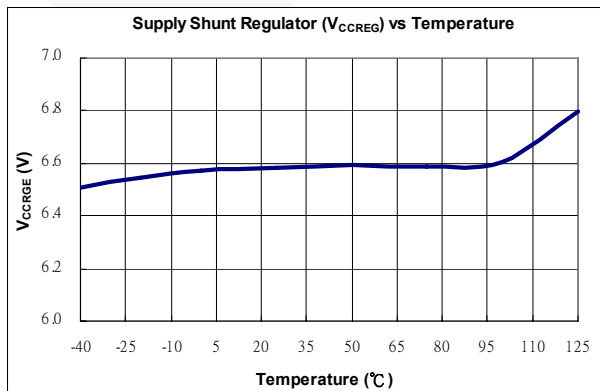

Figure 14. Supply Shunt Regulator ( $V_{CCREG}$ ) vs. Temperature

## Functional Description

**1. Startup and  $V_{CC}$  Regulation:** At startup, an internal high-voltage current source supplies the internal bias and charges the external capacitor ( $C_A$ ) connected to the  $V_{CC}$  pin, as illustrated in Figure 15. An internal high-voltage regulator (HV/REG) located between the D and  $V_{CC}$  pins regulates the  $V_{CC}$  to be 6.5V and supplies operating current. Therefore, FSQ500L needs no auxiliary bias winding.

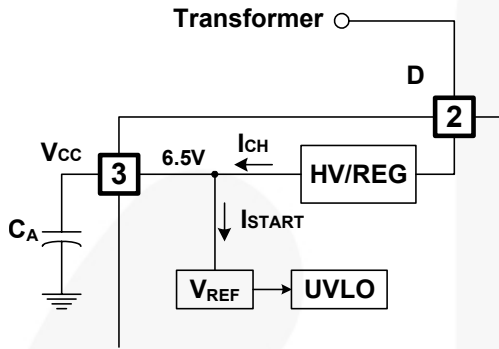

Figure 15. Startup Block

**2. Feedback Control:** FSQ500L employs current mode control, as shown in Figure 16. An opto-coupler (such as the FOD817A) and shunt regulator (such as the KA431) are typically used to implement the feedback network. Comparing the feedback voltage with the voltage across the  $R_{sense}$  resistor makes it possible to control the switching duty cycle. When the reference pin voltage of the regulator exceeds the internal reference voltage of 2.5V, the opto-coupler LED current increases, pulling down the feedback voltage and reducing the duty cycle. This typically happens when the line input voltage increases or the output load current decreases.

**2.1 Pulse-by-Pulse Current Limit:** Because current mode control is employed, the peak current through the senseFET is limited by the non-inverting input of PWM comparator ( $V_{FB}^*$ ), as shown in Figure 16. Assuming that 225 $\mu$ A current source flows only through the internal resistor ( $8R + R = 12k\Omega$ ), the cathode voltage of diode D2 is about 2.7V. Since D1 is blocked when the feedback voltage ( $V_{FB}$ ) exceeds 2.7V, the maximum voltage of the cathode of D2 is clamped at this voltage, clamping  $V_{FB}^*$ . Therefore, the peak value of the current through the senseFET is limited.

**2.2 Leading-Edge Blanking (LEB):** At the instant the internal senseFET is turned on, a high-current spike occurs through the senseFET, caused by primary-side capacitance and secondary-side rectifier reverse recovery. Excessive voltage across the  $R_{sense}$  resistor would lead to incorrect feedback operation in the current mode PWM control. To counter this effect, the FPS employs a leading-edge blanking (LEB) circuit. This circuit inhibits the PWM comparator for a short time ( $t_{LEB} = 250ns$ ) after the senseFET turns on.

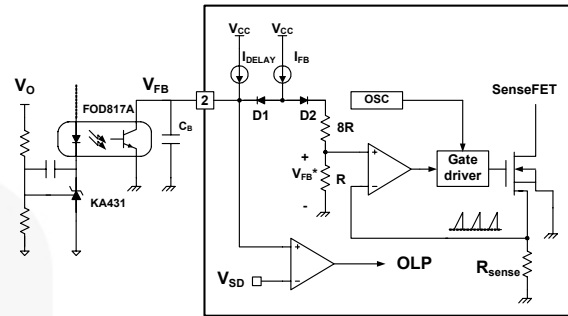

Figure 16. Pulse Width Modulation (PWM) Circuit

**3. Protection Circuits:** The FSQ500L has two self-protective functions: overload protection (OLP) and thermal shutdown (TSD). While OLP is implemented as auto-restart mode, there is no switching when TSD triggers. Once the overload condition is detected, switching is terminated, the senseFET remains off, and HV/REG turns off. This causes  $V_{CC}$  to fall. When  $V_{CC}$  falls below the under voltage lockout (UVLO) stop voltage of 5.0V, the protection is reset and the startup circuit charges the  $V_{CC}$  capacitor. When  $V_{CC}$  reaches the start voltage of 6.0V, the FSQ500L resumes its normal operation. If the fault condition is still not removed, the senseFET and HV/REG remain off and  $V_{CC}$  drops to  $V_{STOP}$  again. In this manner, the auto-restart can alternately enable and disable the switching of the power senseFET until the fault condition is eliminated, as shown in Figure 17.

Because these protection circuits are fully integrated into the IC without external components, reliability is improved without increasing cost.

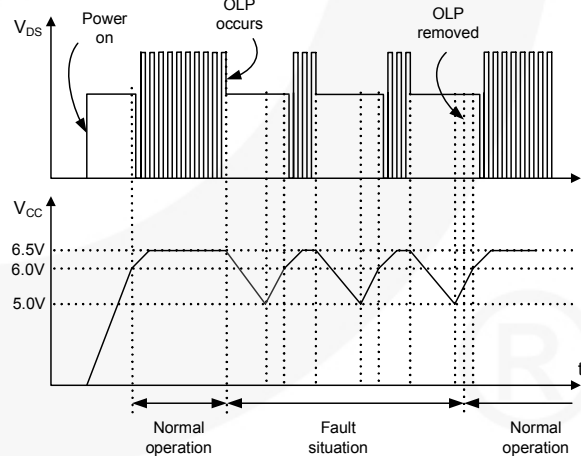

Figure 17. Auto Restart Protection Waveforms



**3.1 Overload Protection (OLP):** Overload is defined as the load current exceeding its normal level due to an unexpected abnormal event. In this situation, the protection circuit should trigger to protect the SMPS. However, even when the SMPS is in the normal operation, the overload protection circuit can be triggered during the load transition. To avoid this undesired operation, the overload protection circuit is designed to trigger after a specified time to determine whether the situation is transient or a true overload. Because of the pulse-by-pulse current limit capability, the maximum peak current through the senseFET is limited and, therefore, the maximum input power is restricted with a given input voltage. If the output consumes more than this maximum power, the output voltage ( $V_O$ ) decreases below the set voltage. This reduces the current through the opto-coupler LED, which also reduces the opto-coupler transistor current, thus increasing the feedback voltage ( $V_{FB}$ ). If  $V_{FB}$  exceeds 2.7V, D1 is blocked and the 5 $\mu$ A current source starts to charge  $C_B$  slowly up to  $V_{CC}$ . In this condition,  $V_{FB}$  continues increasing until it reaches 4.5V, when the switching operation is terminated, as shown in Figure 18. The delay time for shutdown is the time required to charge  $C_B$  from 2.7V to 4.5V with 5 $\mu$ A. In general, a 10 ~ 50ms delay time is typical for most applications. This protection is implemented in auto restart mode.

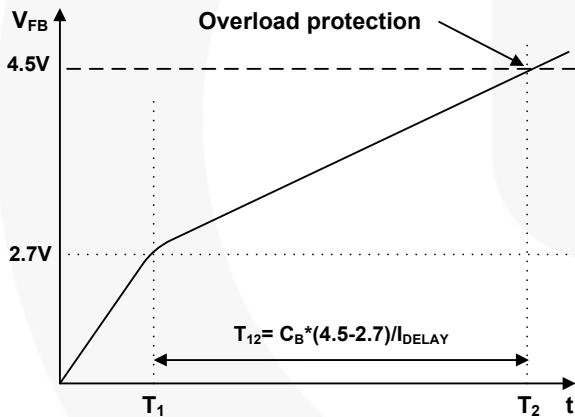

Figure 18. Overload Protection

**3.2 Thermal Shutdown (TSD):** The senseFET and the control IC in one package makes it easy for the control IC to detect an abnormal over temperature of the senseFET. When the temperature exceeds approximately 140°C, the thermal shutdown triggers. When TSD triggers, delay current is disabled, switching operation stops, and  $V_{CC}$  through the internal high-voltage current source is set to 5.7V from 6.5V, as shown in Figure 19. Since TSD signal prohibits the senseFET from switching, there is no switching until the junction temperature decreases sufficiently. If the junction temperature is lower than 60°C typically, TSD signal is removed and  $V_{CC}$  is set to 6.5V again. While  $V_{CC}$  increases from 5.7V to 6.5V, the soft-start function makes the senseFET turn on and off with no voltage and/or current stress.

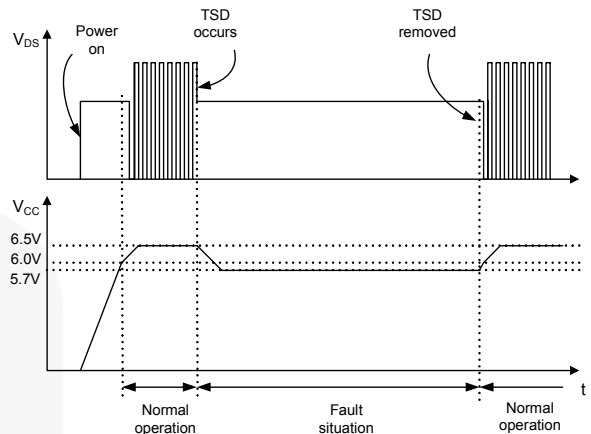

Figure 19. Over-Temperature Protection (OTP)

**4. Soft-Start:** The soft-start time is tuned by an external  $V_{CC}$  capacitor ( $C_A$ ), which increases PWM comparator non-inverting input voltage together with the senseFET current slowly after it starts up. Before  $V_{CC}$  reaches  $V_{START}$ ,  $C_A$  is charged by the current  $I_{CH-ISTART}$ , where  $I_{CH}$  and  $I_{START}$  are described in Figure 15. After  $V_{CC}$  reaches  $V_{START}$ , all internal blocks are activated, so that the current consuming inside IC becomes  $I_{OP}$ . Therefore,  $C_A$  is charged by the current  $I_{CH-IOP}$ , which makes the increasing slope of  $V_{CC}$  become sluggish.  $V_{CC}$  is shifted by 6.0V negatively (it is performed in soft-start block in Figure 2), and then  $V_{CC} - 6.0V$  is an input of one of the input terminals of the PWM comparator. The drain current follows  $V_{CC} - 6.0V$  instead of the  $V_{FB}^*$  because of the low-dominant feature of the PWM comparator. The soft-start time can be made long or short by selecting  $C_A$ , as described in Figure 20. During  $t_{S/S}$ ,  $I_{DELAY}$  is disabled to avoid unwanted OLP. Typically,  $t_{S/S}$  is around 4.6ms with 27 $\mu$ F of  $C_A$ .

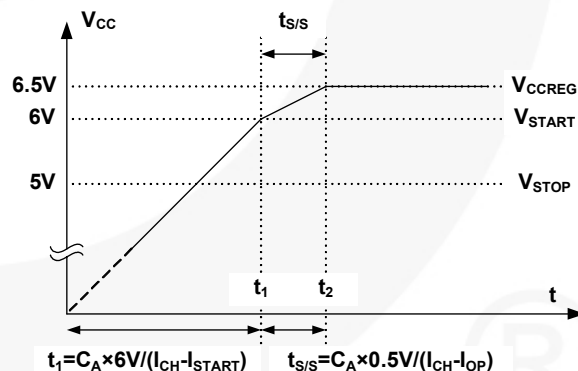

Figure 20. Soft-Start Function

The peak value of the drain current of the power switching device is progressively increased to establish the correct working conditions for transformers, inductors, and capacitors. The voltage on the output capacitors is progressively increased with the intention of smoothly establishing the required output voltage. It also helps to prevent transformer saturation and reduce stress on the secondary diode during startup.

**5. Burst Operation:** To minimize power dissipation in standby mode, the FPS enters burst-mode operation. During the burst mode operation,  $I_{FB(Burst)}$  decreases half of  $I_{FB(Normal)}$ . As the load decreases, the feedback voltage decreases. As shown in Figure 21, the device automatically enters burst mode when the feedback voltage drops below  $V_{BURL}$  (750mV). At this point, switching stops and the output voltages start to drop at a rate dependent on standby current load. This causes the feedback voltage to rise. Once it passes  $V_{BURH}$  (800mV), switching resumes. The feedback voltage then falls and the process repeats. Burst mode alternately enables and disables switching of the power senseFET, reducing switching loss in standby mode.

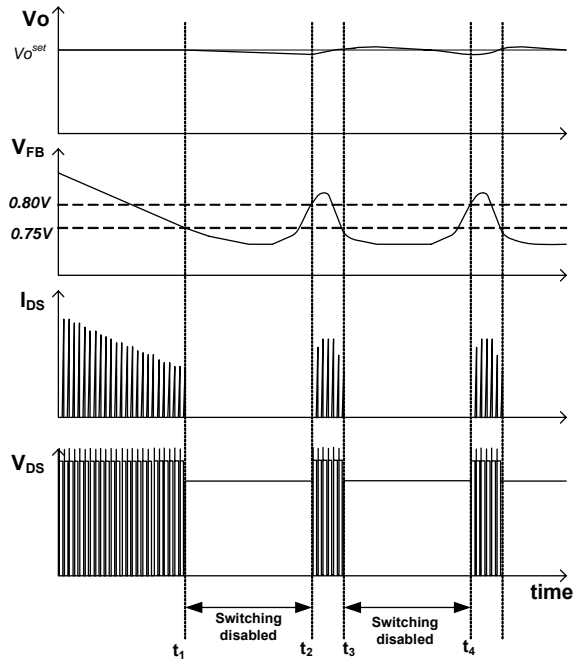
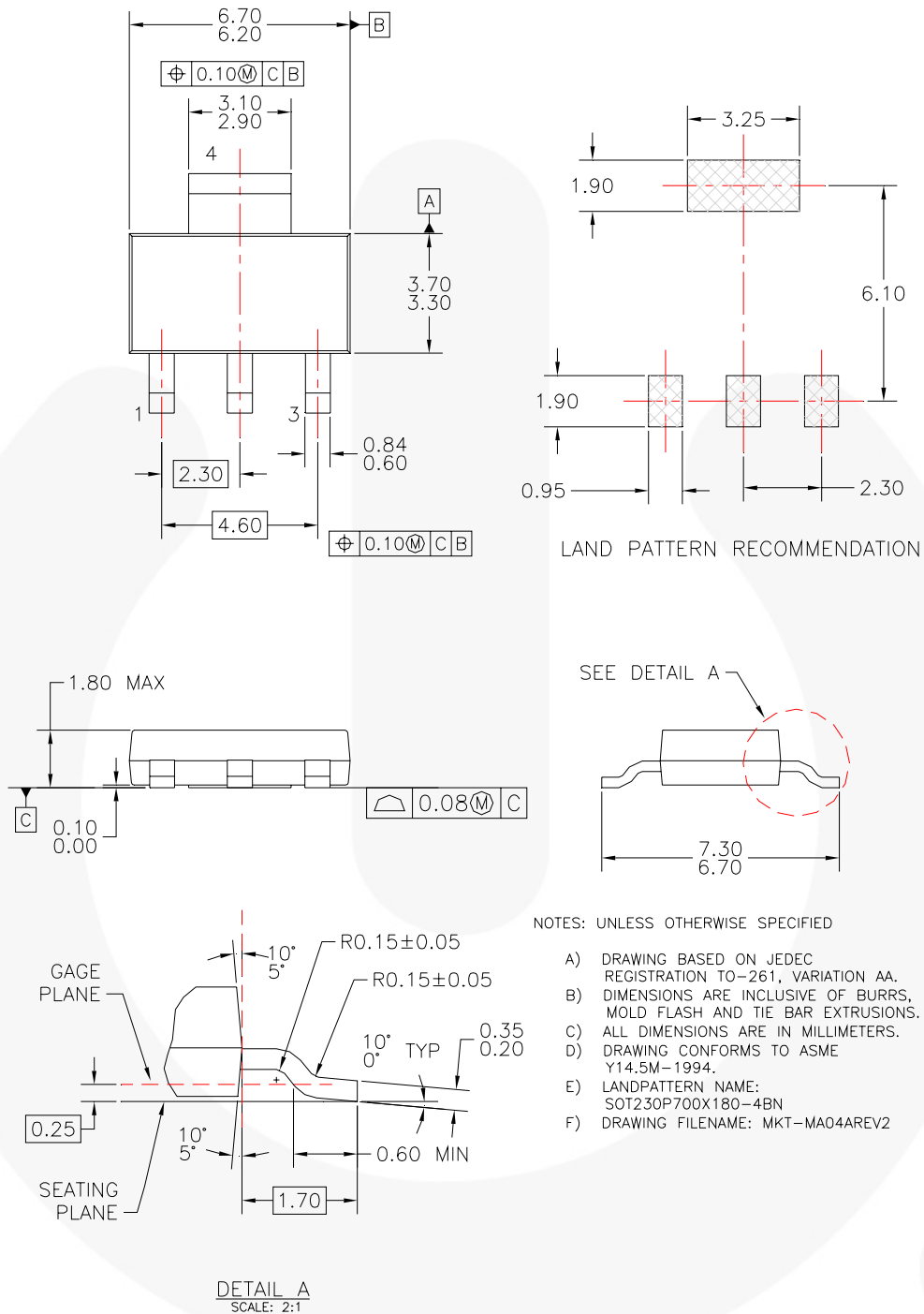

Figure 21. Burst-Mode Operation

### Package Dimensions



**Figure 22.4-Lead, Small Outline Package (SOT223-4L)**





Package drawings are provided as a service to customers considering Fairchild components. Drawings may change in any manner without notice. Please note the revision and/or date on the drawing and contact a Fairchild Semiconductor representative to verify or obtain the most recent revision. Package specifications do not expand the terms of Fairchild's worldwide terms and conditions, specifically the warranty therein, which covers Fairchild products.

Always visit Fairchild Semiconductor's online packaging area for the most recent package drawings:  
<http://www.fairchildsemi.com/packaging/>



**TRADEMARKS**

The following includes registered and unregistered trademarks and service marks, owned by Fairchild Semiconductor and/or its global subsidiaries, and is not intended to be an exhaustive list of all such trademarks.

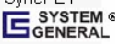
- |   |   |   |   |
|---|---|---|---|
| Build it Now™   | F-PFS™  | PowerTrench®  | The Power Franchise®  |
| CorePLUS™   | FRFET®  | Programmable Active Droop™  | <b>the power franchise</b>  |
| CorePOWER™  | Global Power Resource™  | QFET®   | TinyBoost™  |
| CROSSVOLT™  | Green FPS™  | QST™  | TinyBuck™   |
| CTL™  | Green FPS™ e-Series™  | Quiet Series™   | TinyLogic™  |
| Current Transfer Logic™   | GTOT™   | RapidConfigure™   | TINYOPTO™   |
| EcoSPARK®   | IntelliMAX™   |  | TinyPower™  |
| EfficientMax™   | ISOPLANAR™  | Saving our world, 1mV/VV/kW at a time™  | TinyPWM™  |
| EZSWITCH™ *   | MegaBuck™   | SmartMax™   | TinyWire™   |
|  | MICROCOCOPLER™  | SMART START™  | μSerDes™  |
|  | MicroFET™   | SPM®  |  |
| Fairchild®  | MillerDrive™  | STEALTH™  | UHC®  |
| Fairchild Semiconductor®  | MotionMax™  | SuperFET™   | Ultra FRFET™  |
| FACT Quiet Series™  | Motion-SPM™   | SuperSOT™.3   | UniFET™   |
| FACT®   | OPTOLOGIC®  | SuperSOT™.8   | VCX™  |
| FAST®   | OPTOPLANAR®   | SupreMOS™   | VisualMax™  |
| FastvCore™  |  | SyncFET™  |   |
| FlashWriter® *  | PDP $\mu$ PM™   |  |   |
| FPS™  | Power-SPM™  |   |   |

\* EZSWITCH™ and FlashWriter® are trademarks of System General Corporation, used under license by Fairchild Semiconductor.

**DISCLAIMER**

FAIRCHILD SEMICONDUCTOR RESERVES THE RIGHT TO MAKE CHANGES WITHOUT FURTHER NOTICE TO ANY PRODUCTS HEREIN TO IMPROVE RELIABILITY, FUNCTION, OR DESIGN. FAIRCHILD DOES NOT ASSUME ANY LIABILITY ARISING OUT OF THE APPLICATION OR USE OF ANY PRODUCT OR CIRCUIT DESCRIBED HEREIN; NEITHER DOES IT CONVEY ANY LICENSE UNDER ITS PATENT RIGHTS, NOR THE RIGHTS OF OTHERS. THESE SPECIFICATIONS DO NOT EXPAND THE TERMS OF FAIRCHILD'S WORLDWIDE TERMS AND CONDITIONS, SPECIFICALLY THE WARRANTY THEREIN, WHICH COVERS THESE PRODUCTS.

**LIFE SUPPORT POLICY**

FAIRCHILD'S PRODUCTS ARE NOT AUTHORIZED FOR USE AS CRITICAL COMPONENTS IN LIFE SUPPORT DEVICES OR SYSTEMS WITHOUT THE EXPRESS WRITTEN APPROVAL OF FAIRCHILD SEMICONDUCTOR CORPORATION.

As used herein:

1. Life support devices or systems are devices or systems which, (a) are intended for surgical implant into the body or (b) support or sustain life, and (c) whose failure to perform when properly used in accordance with instructions for use provided in the labeling, can be reasonably expected to result in a significant injury of the user.
2. A critical component in any component of a life support, device, or system whose failure to perform can be reasonably expected to cause the failure of the life support device or system, or to affect its safety or effectiveness.

**ANTI-COUNTERFEITING POLICY**

Fairchild Semiconductor Corporation's Anti-Counterfeiting Policy. Fairchild's Anti-Counterfeiting Policy is also stated on our external website, [www.fairchildsemi.com](http://www.fairchildsemi.com), under Sales Support.

Counterfeiting of semiconductor parts is a growing problem in the industry. All manufacturers of semiconductor products are experiencing counterfeiting of their parts. Customers who inadvertently purchase counterfeit parts experience many problems such as loss of brand reputation, substandard performance, failed applications, and increased cost of production and manufacturing delays. Fairchild is taking strong measures to protect ourselves and our customers from the proliferation of counterfeit parts. Fairchild strongly encourages customers to purchase Fairchild parts either directly from Fairchild or from Authorized Fairchild Distributors who are listed by country on our web page cited above. Products customers buy either from Fairchild directly or from Authorized Fairchild Distributors are genuine parts, have full traceability, meet Fairchild's quality standards for handling and storage and provide access to Fairchild's full range of up-to-date technical and product information. Fairchild and our Authorized Distributors will stand behind all warranties and will appropriately address any warranty issues that may arise. Fairchild will not provide any warranty coverage or other assistance for parts bought from Unauthorized Sources. Fairchild is committed to combat this global problem and encourage our customers to do their part in stopping this practice by buying direct or from authorized distributors.

**PRODUCT STATUS DEFINITIONS**

**Definition of Terms**

Datasheet Identification	Product Status	Definition
Advance Information	Formative / In Design	Datasheet contains the design specifications for product development. Specifications may change in any manner without notice.
Preliminary	First Production	Datasheet contains preliminary data; supplementary data will be published at a later date. Fairchild Semiconductor reserves the right to make changes at any time without notice to improve design.
No Identification Needed	Full Production	Datasheet contains final specifications. Fairchild Semiconductor reserves the right to make changes at any time without notice to improve the design.
Obsolete	Not In Production	Datasheet contains specifications on a product that is discontinued by Fairchild Semiconductor. The datasheet is for reference information only.

Rev. 136