

## General Purpose GaAs FET

### FEATURES

- Medium Power Output:  $P_{1dB}=24.5dBm(Typ.)@8.0GHz$
- High Power Gain:  $G_{1dB}=10dB(Typ.)@8.0GHz$
- Hermetic Metal/Ceramic Package
- Proven Reliability

### DESCRIPTION

The FSX027WF is a general purpose GaAs FET designed for medium power applications up to the 12GHz. These devices have a wide dynamic range and are suitable for use in medium power, wide band, linear drive amplifiers or oscillators.

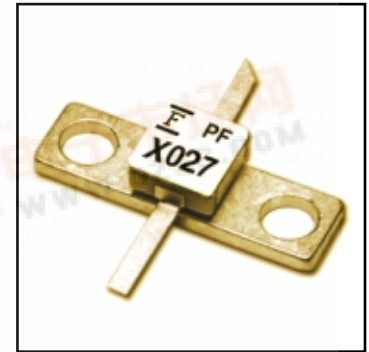

Fujitsu's stringent Quality Assurance Program assures the highest reliability and consistent performance.

### ABSOLUTE MAXIMUM RATINGS (Ambient Temperature $T_a = 25^{\circ}C$ )

Item	Symbol	Condition	Rating	Unit
Drain-Source Voltage	$V_{DS}$		12	V
Gate-Source Voltage	$V_{GS}$		-5	V
Total Power Dissipation	$P_T$	$T_C = 25^{\circ}C$	1.5	W
Storage Temperature	$T_{STG}$		-65 to 175	$^{\circ}C$
Channel Temperature	$T_{CH}$		175	$^{\circ}C$

Fujitsu recommends the following conditions for the reliable operation of GaAs FETs:

1. The drain-source operating voltage ( $V_{DS}$ ) should not exceed 8 volts.
2. The forward and reverse gate currents should not exceed 1.4 and -0.2 mA respectively with gate resistance of 1000 $\Omega$ .
3. The operating channel temperature ( $T_{ch}$ ) should not exceed 145 $^{\circ}C$ .

### ELECTRICAL CHARACTERISTICS (Ambient Temperature $T_a=25^{\circ}C$ )

Item	Symbol	Test Conditions	Limit			Unit
			Min.	Typ.	Max.	
Saturated Drain Current	$I_{DSS}$	$V_{DS} = 3V, V_{GS} = 0V$	70	110	150	mA
Transconductance	$g_m$	$V_{DS} = 3V, I_{DS} = 54mA$	-	100	-	mS
Pinch-off Voltage	$V_p$	$V_{DS} = 3V, I_{DS} = 5.4mA$	-0.7	-1.2	-1.7	V
Gate Source Breakdown Voltage	$V_{GSO}$	$I_{GS} = -5.4\mu A$	-5.0	-	-	V
Noise Figure	NF	$V_{DS} = 3V, I_{DS} = 30mA$	-	2.5	-	dB
Associated Gain	$G_{as}$	$f = 8GHz$	-	9.5	-	dB
Output Power at 1 dB G.C.P.	$P_{1dB}$	$f = 4GHz$	-	24.5	-	dBm
		$f = 8GHz$	23.5	24.5	-	dBm
		$f = 12GHz$	-	23.5	-	dBm
Power Gain at 1 dB G.C.P.	$G_{1dB}$	$f = 4GHz$	-	14.0	-	dB
		$f = 8GHz$	9.0	10.0	-	dB
		$f = 12GHz$	-	6.5	-	dB
Thermal Resistance	$R_{th}$	Channel to Case	-	70	100	$^{\circ}C/W$

CASE STYLE: WF

G.C.P.: Gain Compression Point

# FSX027WF

General Purpose GaAs FET

### POWER DERATING CURVE

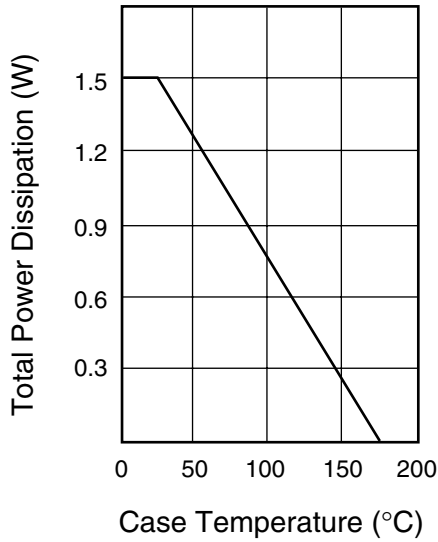

### DRAIN CURRENT vs. DRAIN-SOURCE VOLTAGE

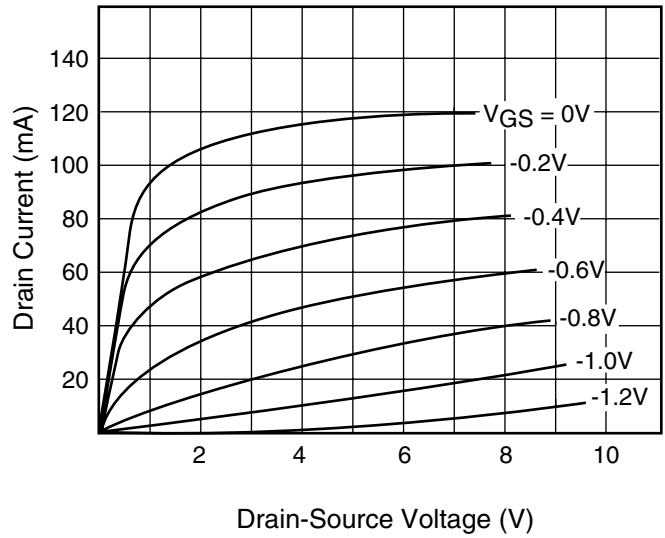

### OUTPUT POWER vs. INPUT POWER

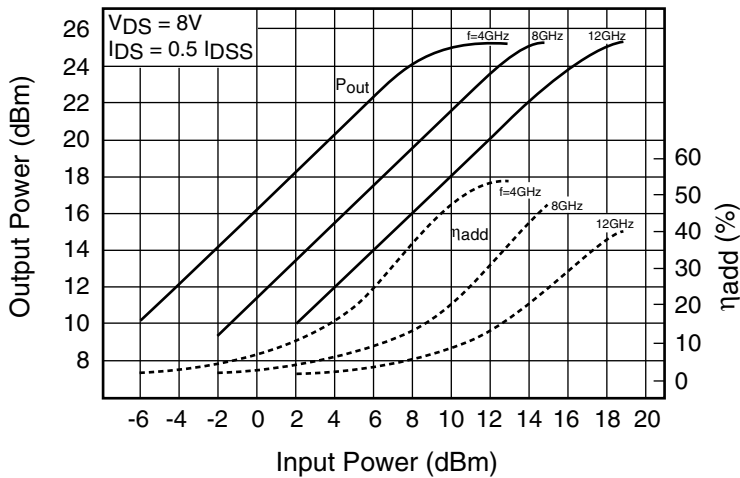

### P 1dB vs. VDS

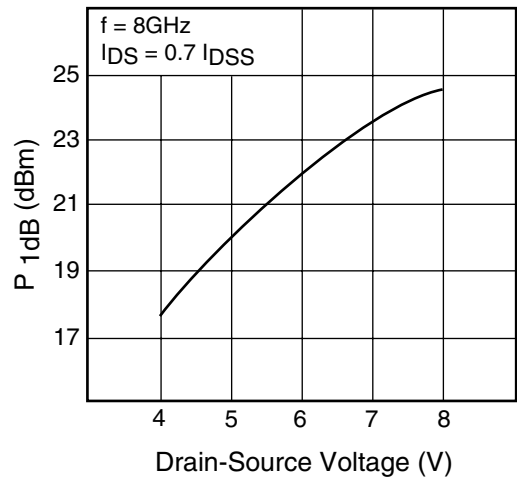

# FSX027WF

## General Purpose GaAs FET

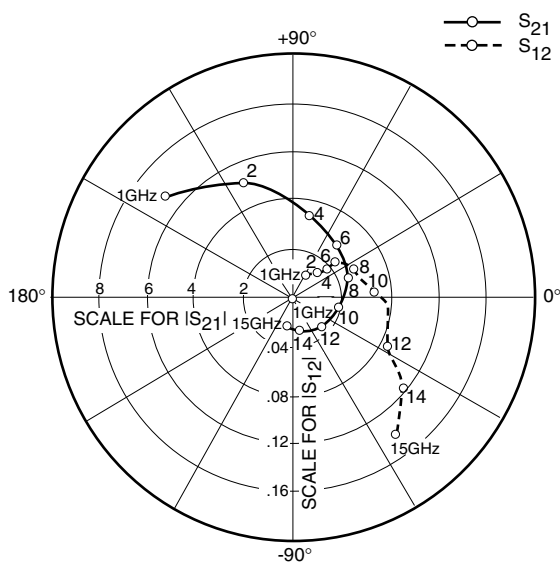
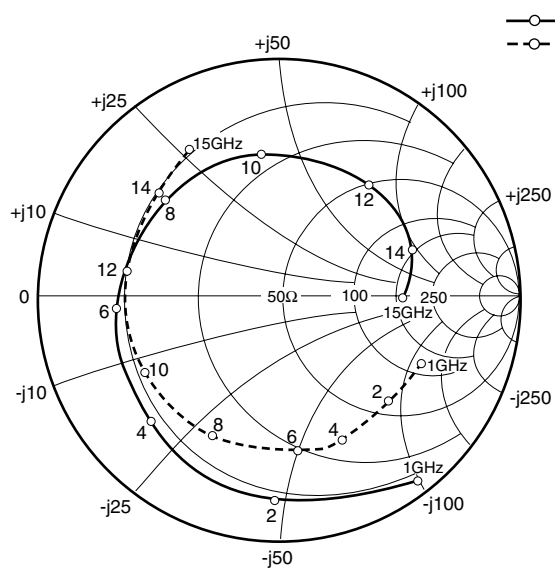

### S-PARAMETERS

$V_{DS} = 8V, I_{DS} = 75mA$

FREQUENCY (MHZ)	S11		S21		S12		S22	
	MAG	ANG	MAG	ANG	MAG	ANG	MAG	ANG
1000	.942	-53.2	6.773	142.1	.021	62.8	.651	-25.8
2000	.852	-91.2	5.211	114.2	.030	47.6	.628	-43.7
3000	.782	-116.0	3.993	94.6	.033	43.1	.635	-56.5
4000	.745	-135.8	3.335	80.7	.035	41.5	.651	-66.8
5000	.710	-155.2	2.994	66.2	.037	44.2	.652	-73.6
6000	.683	-176.8	2.747	51.7	.040	41.3	.642	-83.7
7000	.656	-159.9	2.532	36.2	.048	38.2	.634	-97.6
8000	.638	139.7	2.323	20.2	.054	26.4	.638	-115.9
9000	.618	119.4	2.089	1.4	.057	17.1	.636	-134.5
10000	.601	97.2	1.838	-14.7	.065	3.9	.642	-150.7
11000	.592	73.4	1.639	-30.5	.078	-5.1	.646	-168.5
12000	.591	51.8	1.646	-48.3	.087	-28.1	.647	172.6
13000	.600	33.6	1.401	-67.1	.093	-31.1	.651	155.2
14000	.582	19.1	1.409	-82.1	.117	-38.7	.668	139.4
15000	.499	-0.7	1.246	-103.6	.139	-53.2	.705	121.8

# FSX027WF

## General Purpose GaAs FET

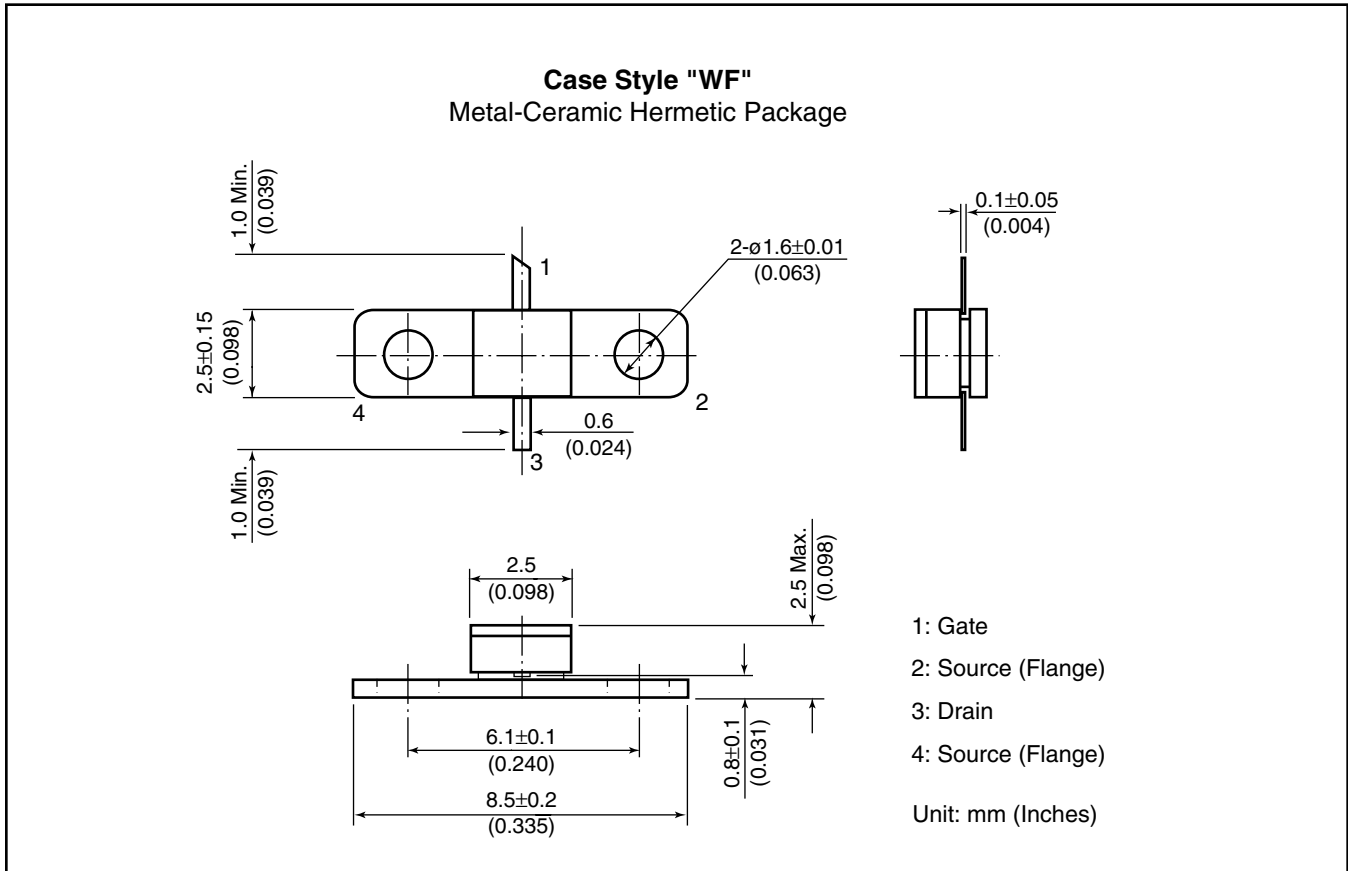

For further information please contact:

### FUJITSU COMPOUND SEMICONDUCTOR, INC.

2355 Zanker Rd.

San Jose, CA 95131-1138, U.S.A.

Phone: (408) 232-9500

FAX: (408) 428-9111

www.fcsi.fujitsu.com

### FUJITSU MICROELECTRONICS EUROPE, GmbH

#### Quantum Devices Division

Network House

Norreys Drive

Maidenhead, Berkshire SL6 4FJ

Phone: +44 (0)1628 504800

FAX: +44 (0)1628 504888

### CAUTION

Fujitsu Compound Semiconductor Products contain **gallium arsenide (GaAs)** which can be hazardous to the human body and the environment. For safety, observe the following procedures:

- Do not put these products into the mouth.
- Do not alter the form of this product into a gas, powder, or liquid through burning, crushing, or chemical processing as these by-products are dangerous to the human body if inhaled, ingested, or swallowed.
- Observe government laws and company regulations when discarding this product. This product must be discarded in accordance with methods specified by applicable hazardous waste procedures.

Fujitsu Limited reserves the right to change products and specifications without notice. The information does not convey any license under rights of Fujitsu Limited or others.

© 1998 FUJITSU COMPOUND SEMICONDUCTOR, INC.

Printed in U.S.A. FCSI0598M200