

TOLERANCE UNLESS SPECIFIED = .XXX = +/- .005 .XX = +/- .015 FRACTIONS = +/- .032
 FS12-200.DC2

YYMM = YEAR, WEEK
 XXX = SITECODE

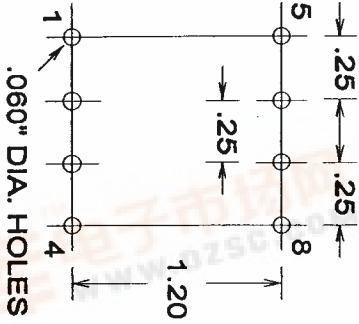

EIA-17-YYMM
 XXX B10

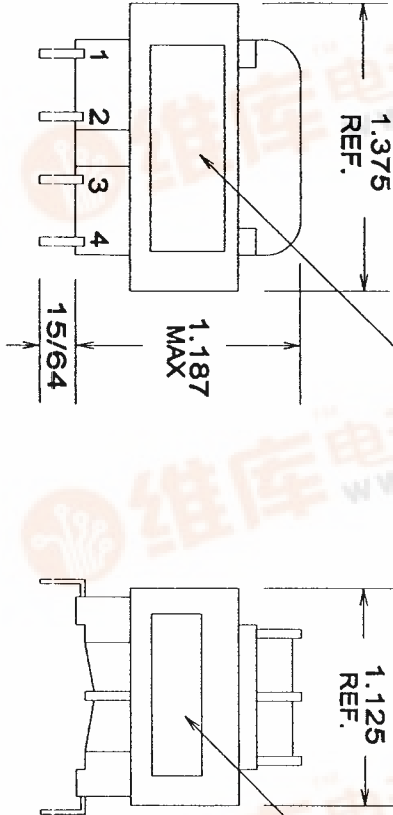

PRODUCTION TESTS

DC	(1-2)	675 TO 815
RESISTANCE	(3-4)	825 TO 970
IN OHMS	(5-6)	2.3 TO 3.5
	(7-8)	2.9 TO 4.4

TURN RATIO = 100%

MAX EXCITATION CURRENT = .010 AMPS

APPLY = 230V, 60HZ PINS 1-4

CONNECT PINS 2-3

OPEN CIRCUIT VOLTAGE TEST:

APPLY 230V/60HZ PINS 1-4, CON. 2-3

READ 7.6 TO 8.0 EACH SECONDARY

HIPOT = 2500V P-S

1500V P-C, S-C

500V P-P, S-S

CONTINUITY = 100% PRIMARY

IMPREGNATION NOTES = 2 HOUR PREHEAT
 PINS MUST BE FREE OF IMPREG.

FINAL ASSEMBLY NOTES

METHOD

1 X 1

MARKING

SEE LABEL DETAIL ABOVE



PART NO.: FS12-200

