

TOLERANCE UNLESS SPECIFIED = .XXX = +/- .005 .XX = +/- .015 FRACTIONS = +/- .032

FS36-65.DC2

YYWW = YEAR, WEEK
XXX = SITECODE

M MagnaTek - Triad
FS36-65
CLASS B **PA** us

EA-17-YYWW
XXX B10

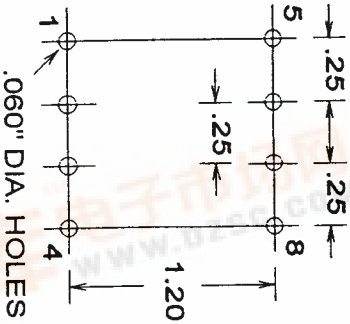
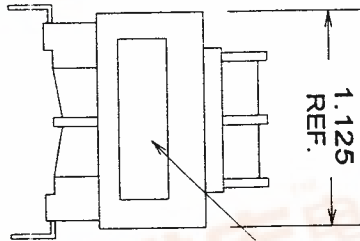
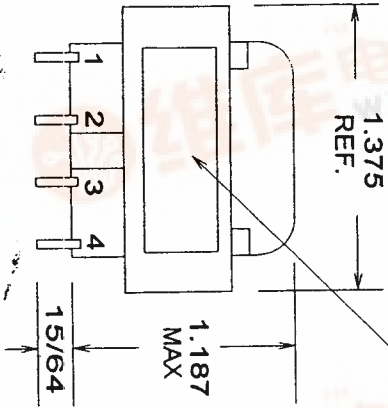

PRODUCTION TESTS

TURNS RATIO = 100%	
DC	(1-2) 675 TO 815
RESISTANCE	(3-4) 825 TO 970
IN OHMS	(5-6) 26.5 TO 31.2
	(7-8) 32 TO 38

MAX EXCITATION CURRENT = .010 AMPS
APPLY = 230V, 60Hz PINS 1-4

CONNECT PINS 2-3
OPEN CIRCUIT VOLTAGE TEST:

APPLY 230V/60HZ PINS 1-4, CON. 2-3
READ 21.7 TO 22.7 EACH SECONDARY

HIPOT = 2500V P-S, P-C, S-C
500V S-S, P-P

CONTINUITY = 100% PRIMARY
IMPREGNATION NOTES = 2 HOUR PREHEAT
PINS MUST BE FREE OF IMPREG.

FINAL ASSEMBLY NOTES

M MagnaTek

PART NO. FS36-65

METHOD

1 X 1

MARKING

SEE LABEL DETAIL ABOVE