

24V DRIVE, ULTRA HIGH SPEED LINE THERMAL PRINTER 3" MECHANISM

FTP-631MCL101/102

■ OVERVIEW

This thermal printer (driven by 24 VDC) provides ultra-high speed printing for 3-inch wide paper (85 mm). This printer is small in size, light weight, and has low power consumption. The print head is designed with open construction for easy maintenance.

This printer is suitable for a variety of applications, such as POS terminals, ticket machines, label printers, measuring devices and medical equipment.

In addition to the interface board, a driving LSI (MCU + Gate Array) is also available.

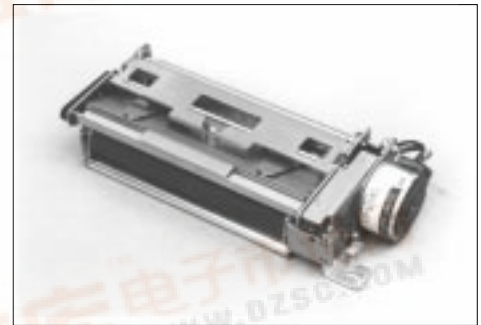

FTP-631MCL101, 102

■ HIGHLIGHTS

- **Ultra high speed printing**
It can print at 100 mm/s (800 dotlines/s) by using Fujitsu Components' unique head drive control system.
 - **Compact and lightweight**
The printer has a low profile of only 28 mm, and a light weight of approximately 260 g.
 - **Low power consumption**
The peak current for head driving is approximately 5.2 A (at 50 mm/s printing speed, 50% printing ratio).
 - **Easy head access**
Head-open construction makes head maintenance easy, especially for head cleaning.
 - **Paper auto loading function**
The thermal paper can be loaded without head-up lever operation.
 - **High resolution**
8 dots/mm head provides clear print output.
 - **Selectable paper paths**
Front or rear insertion types are available.
- FTP-631MCL102 can print on paper thicknesses of up to 150 μ m.



FTP-621CU102, FTP-633GA101

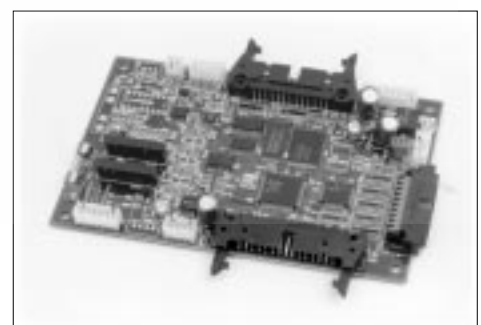

FTP-621DCL002

FTP-631MCL101/102

■ DESIGNATION

Item		Part number
Printer mechanism	Front paper insertion type	FTP-631MCL101
	Rear paper insertion type (supports thick paper)	FTP-631MCL102
Interface board		FTP-621DCL002
LSI	Micro Controller Unit	FTP-621CU102
	Gate Array	FTP-633GA101

■ GENERAL SPECIFICATIONS

Item	Specifications	
Printing method	Thermal-sensitive line dot method	
Dot structure	640 dots/line	
Dot pitch (Horizontal)	0.125 mm (8 dots/mm)—Dot density	
Dot pitch (Vertical)	0.125 mm (8 dots/mm)—Line feed pitch	
Effective printing area	80 mm	
Number of columns	53 columns/line (maximum)—Alphanumeric KANA	
Maximum printing speed	800 dotlines/s (100 mm/s) maximum	
Character types	JIS ANK : 128 International characters : 130 Semi-graphic : 63 ASCII small characters : 31 Download : 384	
Character composition, dimensions (H×W), Number of columns (standard)	24 × 12 dots, (3.0 × 1.5 mm), 53 columns 32 × 16 dots, (4.0 × 2.0 mm), 40 columns 24 × 24 dots, (3.0 × 3.0 mm), 26 columns 32 × 32 dots, (4.0 × 4.0 mm), 20 columns	
Interface	1) Centronics standard 2) Bus interface*1	
Power supply	For head	24 VDC ± 5%, average:*2 0.33 (1.72) A (at 25 mm/s printing speed, 25% printing ratio) 0.64 (2.58) A (at 50 mm/s printing speed, 25% printing ratio) 2.37 (4.29) A (at 100 mm/s printing speed, 25% printing ratio) (): Peak
	For motor	24 VDC ± 5%, 1.0 A maximum
	For logic	5 VDC ± 5%, 0.5 A maximum
Weight	Mechanism: approximately 260 g. Interface board: approximately 100 g	
Dimensions	Mechanism Interface board	130 (W) × 48 (D) × 28.0 (H) mm (excluding connector) 140 (W) × 89 (D) × 24.0 (H) mm

(Continued)

FTP-631MCL101/102

(Continued)

Item		Specifications
Thermal head life		Pulse durability : 1×10^8 pulse/dot (using Fujitsu Takamisawa's standard driving method) Wear resistance: 50 km (at 25% printing ratio)
Environmental conditions	Operating temperature	+5 to +40°C*3
	Operating humidity	20 to 85% RH (no condensation)
	Storage temperature	-20 to +60°C (excluding paper)
	Storage humidity	5 to 95% RH (no condensation)
Detection	Head temperature	By thermistor (applied energy control, abnormal temperature detection)
	Paper out/Mark detect	By photointerrupter (command set)
	Head-up	By microswitch
Paper width		85 ⁺⁰ ₋₁ mm
Recommended thermal sensitive paper*5		1 ply paper in roll : FTP-030P0020 Thicker paper in roll : FTP-030PJ102*4

- *1: The data to be printed is automatically read out by the printer driver equipment memory (host system frame memory). The communication is parameter transfer.
- *2: At 25°C, maximum applied voltage, minimum head resistance, specified paper, stable printing ratio.
- *3: Temperature range for guaranteed printing density. It can operate at 0 to +40°C.
- *4: Printer mechanism FTP-631MCL102 is to be used.
- *5: Please contact us for other thermal papers.

FTP-631MCL101/102

■ DIMENSIONS

Printer mechanism

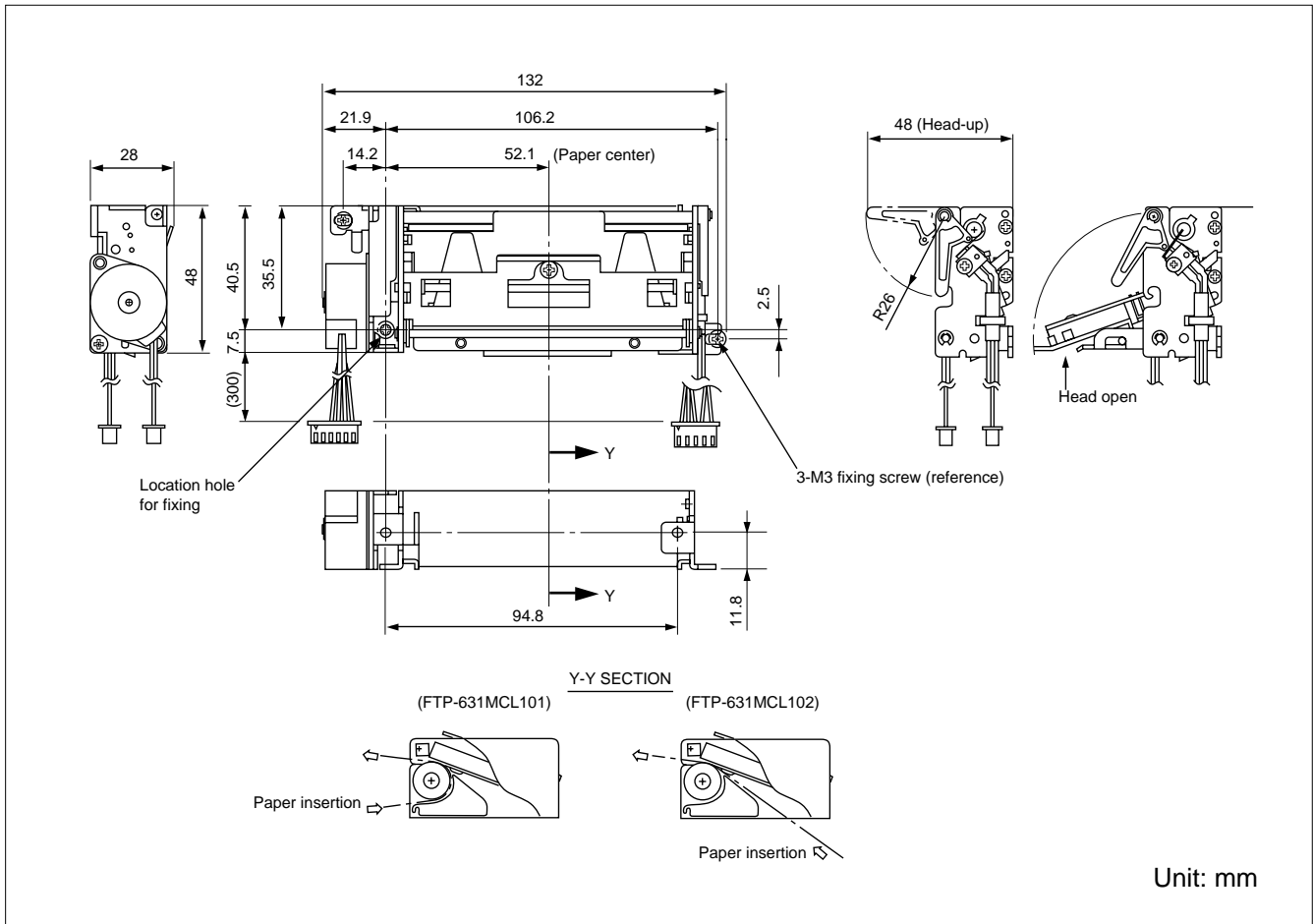

Interface board

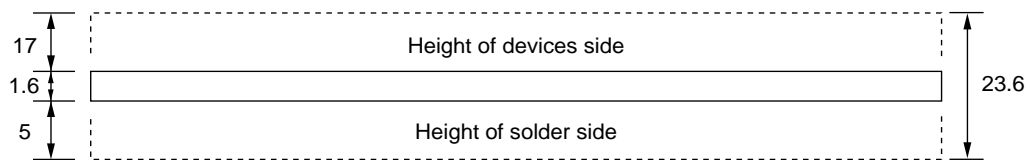
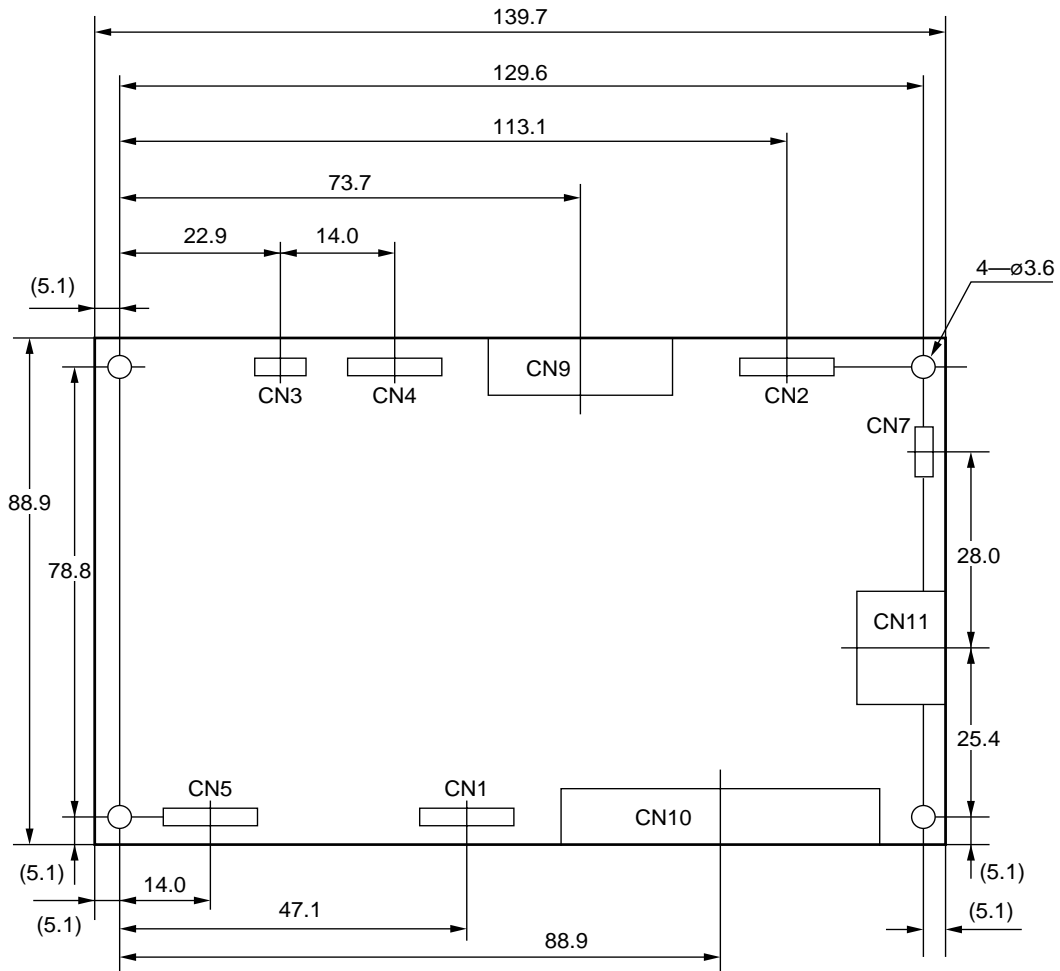

Unit: mm

■ INTERFACE, COMMAND, OPTIONS

Please refer to the FTP-621DCL002/012 DATA SHEET for Interface, Command, and Options.

Fujitsu Components International Headquarter Offices

Japan

Fujitsu Component Limited
Gotanda-Chuo Building
3-5, Higashigotanda 2-chome, Shinagawa-ku
Tokyo 141, Japan
Tel: (81-3) 5449-7010
Fax: (81-3) 5449-2626
Email: promothq@ft.ed.fujitsu.com
Web: www.fcl.fujitsu.com

North and South America

Fujitsu Components America, Inc.
250 E. Caribbean Drive
Sunnyvale, CA 94089 U.S.A.
Tel: (1-408) 745-4900
Fax: (1-408) 745-4970
Email: marcom@fcai.fujitsu.com
Web: www.fcai.fujitsu.com

Europe

Fujitsu Components Europe B.V.
Diamantlaan 25
2132 WV Hoofddorp
Netherlands
Tel: (31-23) 5560910
Fax: (31-23) 5560950
Email: info.marketing@fceu.fujitsu.com
Web: www.fceu.fujitsu.com

Asia Pacific

Fujitsu Components Asia Ltd.
102E Pasir Panjang Road
#04-01 Citilink Warehouse Complex
Singapore 118529
Tel: (65) 375-8560
Fax: (65) 273-3021
Email: fcal@fcal.fujitsu.com
www.fcal.fujitsu.com