

**Olympian Plus  
 General Purpose Filter  
 1/4", 3/8", 1/2", 3/4" Port Sizes**

- Olympian Plus plug in design
- High efficiency water and particle removal
- Quick release bayonet bowl
- High visibility prismatic sight glass\*
- Optional service indicator

\* UK and other patents pending



**Technical Data**

Fluid: Compressed air

Maximum pressure:

Guarded transparent bowl: 10 bar (150 psig)

Metal bowl: 17 bar (250 psig)

Operating temperature\*:

Guarded transparent bowl: -20° to +50°C (0° to +125°F)

Metal bowl: -20° to +80°C (0° to +175°F)

\* Air supply must be dry enough to avoid ice formation at temperatures below +2°C (+35°F).

Partial removal: 5 µm, 25 µm or 40 µm. Within ISO 8573-1, Class 3 and Class 5

Typical flow at 6,3 bar (90 psig) inlet pressure and 0,5 bar (7 psig) pressure drop:

5 µm element: 55 dm<sup>3</sup>/s (116 scfm)

40 µm element: 70 dm<sup>3</sup>/s (148 scfm)

Automatic drain connection: 1/8"

Automatic drain operating conditions:

Minimum pressure: 0,7 bar (10 psig). Drain opens when bowl pressure drops below 0,2 bar (3 psig).

Minimum air flow: 1 dm<sup>3</sup>/s (2 scfm) required to close drain.

Nominal bowl size: 0,2 litre (7 fluid ounce)

**Materials:**

Body: Zinc

Yoke: Zinc

Metal bowl: Aluminium

Standard metal bowl prismatic liquid level indicator lens: Grilamid

Optional metal bowl sight glass: Pyrex

Optional transparent bowl: Polycarbonate

Element: Sintered plastic

Elastomers: Synthetic rubber

**Ordering Information**

See *Ordering Information* on the following pages.

**ISO Symbols**

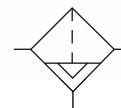

Automatic Drain

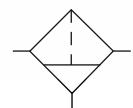

Manual Drain



F64G

Typical Performance Characteristics

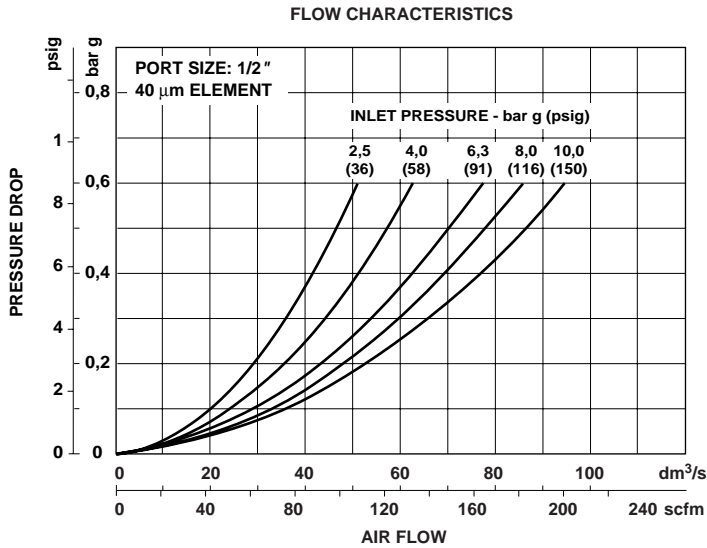

**Ordering Information.** Models listed include ISO G threads, automatic drain, metal bowl, 40 µm element. Models do not include the service life indicator.

Port Size	Model	Flow† dm³/s (scfm)	Weight kg (lb)
G1/4	F64G-2GN-AD3	33 (70)	1,42 (3.13)
G3/8	F64G-3GN-AD3	66 (140)	1,42 (3.13)
G1/2	F64G-4GN-AD3	70 (148)	1,32 (2.91)
G3/4	F64G-6GN-AD3	N.A.	1,72 (3.79)

† Typical flow with a 40 µm element at 6,3 bar (90 psig) inlet pressure and a 0,5 bar (7 psig) pressure drop.

For replacement Filter (without yoke) substitute 'N' at the 5th and 6th digits eg: F64G-**NNN**-AD3.

Alternative Models



Port Size	Substitute
1/4"	2
3/8"	3
1/2"	4
3/4"	6

Threads	Substitute
PTF	A
ISO Rc taper	B
ISO G parallel	G

Service Life Indicator	Substitute
With	D
Without	N

Element	Substitute
5 µm	1
25 µm	2
40 µm	3

Bowl	Substitute
Metal with liquid level indicator	D
Transparent with guard	P
Closed bowl*	E

Drain	Substitute
Manual	M
Auto drain	A

\* For vacuum use.

Accessories

Wall Mounting Bracket	Service Indicator
74504-50	
	Factory fit option only
	See alternative models table



**Dimensions mm (inches)**

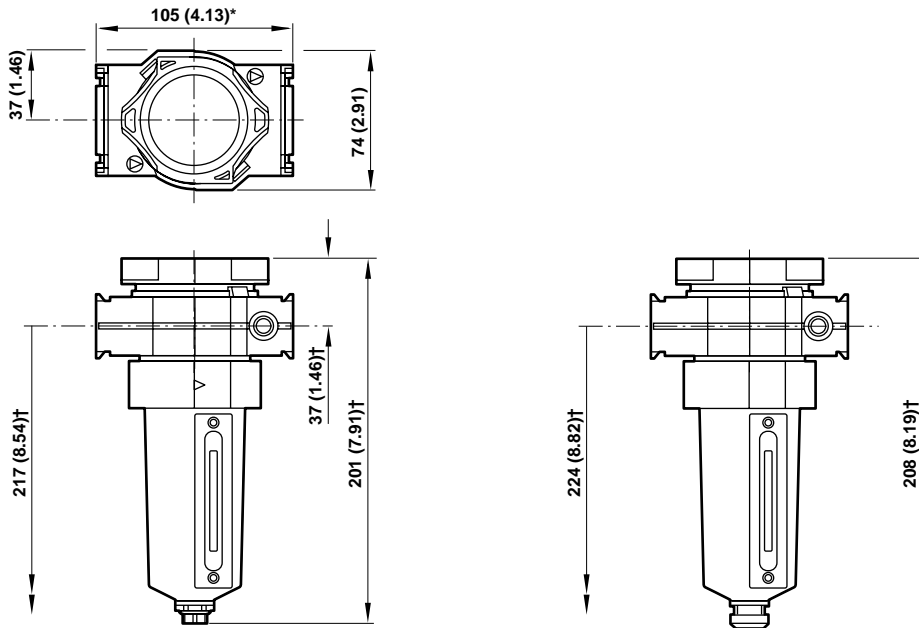

† Minimum clearance required to remove bowl.

\* 157 mm (6.18") for G3/4 models

**Bracket Mounting**

Use 8 mm (5/16") screws to mount bracket to wall.

**Bracket Kit Reference**

Item	Part Number
Wall Bracket	74504-50

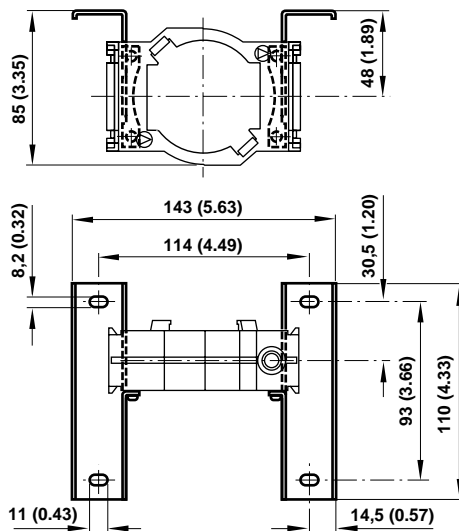

**Service Kits**

Item	Type	Part Number
Service kit	Seal and gasket	4380-200
Elements	5 µm	4338-01
	25 µm	4338-99
	40 µm	4338-02
Service Life Indicator		5797-50
Liquid level lens kit	Prismatic	4380-040
	Pyrex	4380-041
Replacement drains	Automatic	3000-97
	Manual	684-84

Service kit includes port seals, louvre o-ring, bowl o-ring and drain gasket.



## Warning

These products are intended for use in industrial compressed air systems only. Do not use these products where pressures and temperatures can exceed those listed under 'Technical Data'.

Before using these products with fluids other than those specified, for non-industrial applications, life-support systems, or other applications not within published specifications, consult NORGREN.

Through misuse, age, or malfunction, components used in fluid power systems can fail in various modes. The system designer is warned to consider the failure modes of all component parts used in fluid power systems and to provide adequate safeguards to prevent personal injury or damage to equipment in the event of such failure.

**System designers must provide a warning to end users in the system instructional manual if protection against a failure mode cannot be adequately provided.**

System designers and end users are cautioned to review specific warnings found in instruction sheets packed and shipped with these products.

Water vapor will pass through these units and will condense into liquid if air temperature drops in the downstream system. Install an air dryer if water condensation could have a detrimental effect on the application.