

GBAS70/A/C/S

SURFACE MOUNT, SCHOTTKY BARRIER DIODE
VOLTAGE 70V, CURRENT 70mA

Description

These Schottky barrier diodes are designed for high speed switching applications, circuit protection and voltage clamping. Extremely low forward voltage reduces conduction loss. Miniature surface mount package is excellent for hand held and portable applications where space is limited.

Package Dimensions

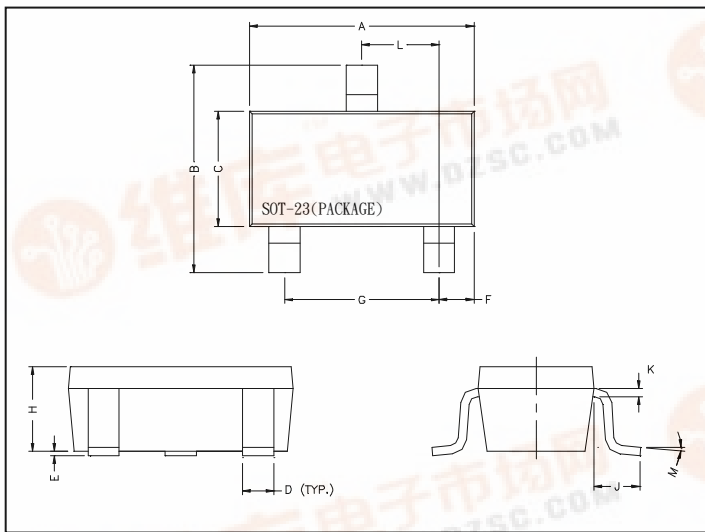

REF.	Millimeter		REF.	Millimeter	
	Min.	Max.		Min.	Max.
A	2.70	3.10	G	1.90	REF.
B	2.40	2.80	H	1.00	1.30
C	1.40	1.60	K	0.10	0.20
D	0.35	0.50	J	0.40	-
E	0	0.10	L	0.85	1.15
F	0.45	0.55	M	0°	10°

Marking :

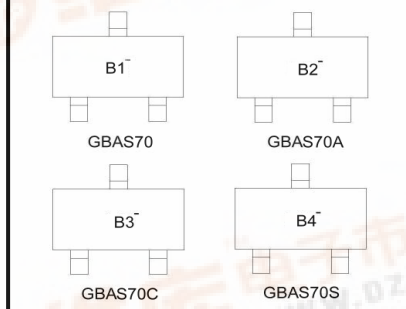
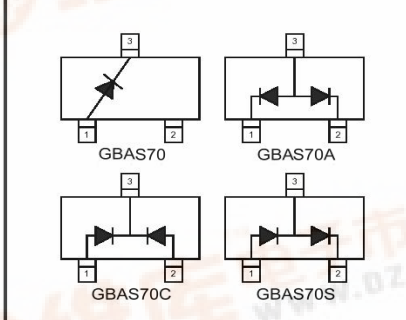

Diagram:



Absolute Maximum Ratings at TA = 25°C

Parameter	Symbol	Ratings	Unit
Operating Junction Temperature	T _j	+125	°C
Storage Temperature	T _{stg}	-65 ~ +125	°C
Maximum Repetitive Peak Reverse Voltage	V _{RRM}	70	V
Maximum Average Forward Rectified Current	I _o	70	mA
Non- Repetitive Peak Forward Surge Current @ t _p ≤ 1.0s	I _{FSM}	100	mA
Thermal Resistance Junction to Ambient Air	R _{θJA}	445	°C/W
Total Power Dissipation	PD	225	mW

Electrical Characteristics (at TA = 25°C unless otherwise noted)

Parameter	Symbol	Min.	Typ.	Max.	Unit	Test Conditions
Reverse Breakdown Voltage	V _{(BR)R}	70	-	-	V	I _R =10μA
Forward Voltage	V _F	-	-	410	mV	I _F =1mA
		-	-	750		I _F =10mA
		-	-	1000		I _F =15mA
Reverse Leakage Current	I _R	-	-	100	nA	V _R 1=50V
		-	-	10		V _R 2=70V
Total Capacitance	C _T	-	-	2.0	pF	V _R =0V, f=1MHz
Reverse Recover Time	T _{rr}	-	-	5.0	ns	I _F =I _R =10mA, R _L =100Ω, I _{rr} =1mA



Characteristics Curve

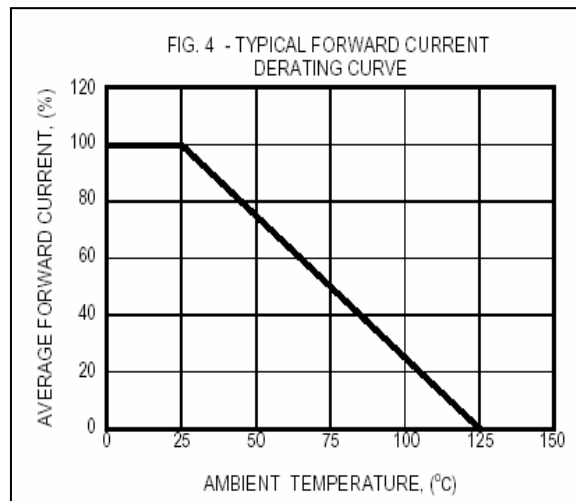
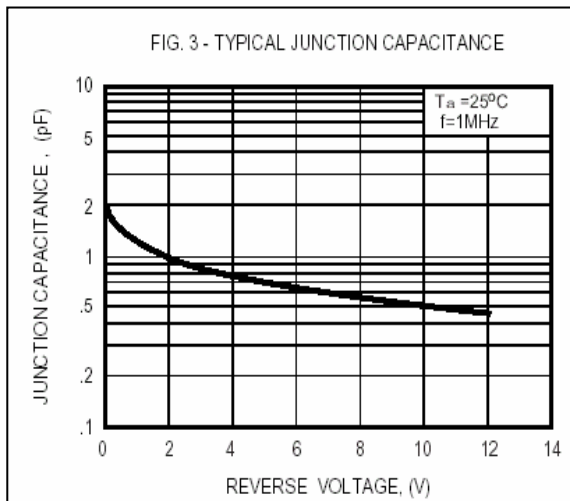
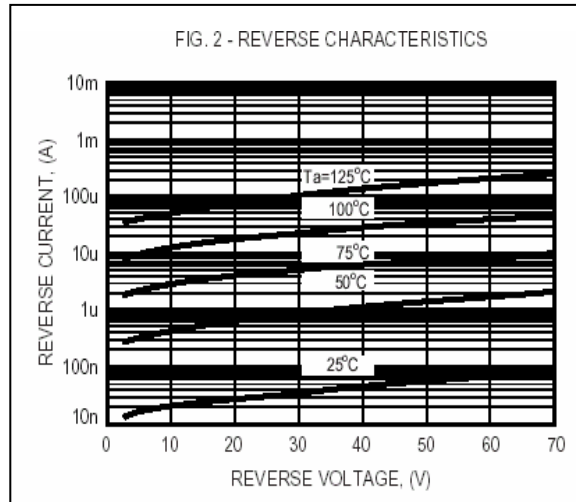
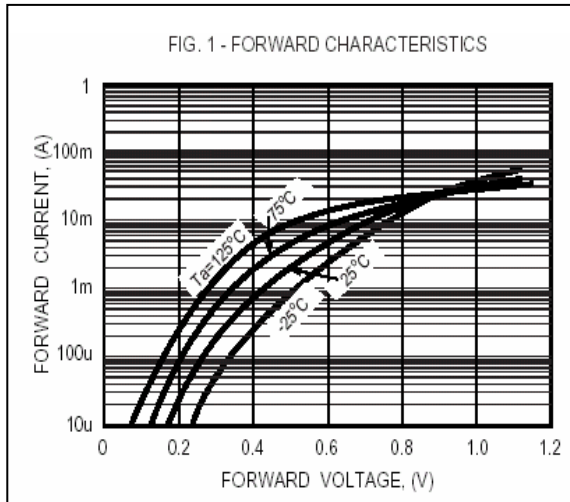

Important Notice:

- All rights are reserved. Reproduction in whole or in part is prohibited without the prior written approval of GTM.
- GTM reserves the right to make changes to its products without notice.
- GTM semiconductor products are not warranted to be suitable for use in life-support Applications, or systems.
- GTM assumes no liability for any consequence of customer product design, infringement of patents, or application assistance.

Head Office And Factory:

- **Taiwan:** No. 17-1 Tatung Rd. Fu Kou Hsin-Chu Industrial Park, Hsin-Chu, Taiwan, R. O. C.
 TEL : 886-3-597-7061 FAX : 886-3-597-9220, 597-0785
- **China:** (201203) No.255, Jang-Jiang Tsai-Lueng RD. , Pu-Dung-Hsin District, Shang-Hai City, China
 TEL : 86-21-5895-7671 ~ 4 FAX : 86-21-38950165