



82541ER Gigabit Ethernet Controller

Networking Silicon

Datasheet

Product Features

- PCI Bus
 - PCI revision 2.3, 32-bit, 33/66 MHz
 - Algorithms that optimally use advanced PCI, MWI, MRM, and MRL commands
 - 3.3 V (5 V tolerant PCI signaling)
 - MAC Specific
 - Low-latency transmit and receive queues
 - IEEE 802.3x-compliant flow-control support with software-controllable thresholds
 - Caches up to 64 packet descriptors in a single burst
 - Programmable host memory receive buffers (256 B to 16 KB) and cache line size (16 B to 256 B)
 - Wide, optimized internal data path architecture
 - 64 KB configurable Transmit and Receive FIFO buffers
 - PHY Specific
 - Integrated for 10/100/1000 Mb/s operation
 - IEEE 802.3ab Auto-Negotiation support
 - IEEE 802.3ab PHY compliance and compatibility
 - State-of-the-art DSP architecture implements digital adaptive equalization, echo cancellation, and cross-talk cancellation
 - Automatic polarity detection
 - Automatic detection of cable lengths and MDI vs. MDI-X cable at all speeds
 - Host Off-Loading
 - Transmit and receive IP, TCP, and UDP checksum off-loading capabilities
 - Transmit TCP segmentation
 - Advanced packed filtering
 - Jumbo frame support up to 16 KB
 - Intelligent Interrupt generation (multiple packets per interrupt)
 - Manageability
 - Network Device Class Power Management Specification 1.1
 - Compliance with PCI Power Management 1.1 and ACPI 2.0
 - SNMP and RMON statistic counters
 - D0 and D3 power states
 - Additional Device
 - Four programmable LED outputs
 - On-chip power control circuitry
 - BIOS LAN Disable pin
 - JTAG (IEEE 1149.1) Test Access Port built in silicon
 - Lead-free^a 196-pin Ball Grid Array (BGA). Devices that are lead-free are marked with a circled “e1” and have the product code: LUxxxxxx.
- a. This device is lead-free. That is, lead has not been intentionally added, but lead may still exist as an impurity at <1000 ppm. The Material Declaration Data Sheet, which includes lead impurity levels and the concentration of other Restriction on Hazardous Substances (RoHS)-banned materials, is available at:
ftp://download.intel.com/design/packtech/material_content_IC_Package.pdf#pagemode=bookmarks
In addition, this device has been tested and conforms to the same parametric specifications as previous versions of the device.
For more information regarding lead-free products from Intel Corporation, contact your Intel Field Sales representative



Revision History

Date	Revision	Notes
Aug 2003	2.0	Non-classified release.
Mar 2004	3.0	Updated Section 4, "Voltage, Temperature, and Timing Specifications," for the C-0 stepping.
Oct 2004	3.1	<ul style="list-style-type: none">Corrected EEMODE signal description.Updated signal names to match design guide and reference schematics.
Nov 2004	3.2	<ul style="list-style-type: none">Added lead free information.Added information about migrating from a 2-layer 0.36 mm wide-trace substrate to a 2-layer 0.32 mm wide-trace substrate. Refer to the section on Package and Pinout Information.Added statement that no changes to existing soldering processes are needed for the 2-layer 0.32 mm wide-trace substrate change in the section describing "Package Information".Corrected pinout discrepancies between sections "Signal Descriptions" and "Package and Pinout Information".
Jan 2005	3.3	<ul style="list-style-type: none">Added new maximum values for DC supply voltages on 1.2 V and 1.8 V pins. See Table 2, Recommended Operating Conditions and Table 6, DC Characteristics.
Feb 2005	3.4	<ul style="list-style-type: none">Updated Visual Pin Assignment diagram for pinouts F9, F10, E14, F14, and H14.
Apr 2005	3.5	<ul style="list-style-type: none">Removed all references to CLK_RUN# signal.Corrected the FLSH_SO/LAN_DISABLE signal definition. If Flash functionality is not used then an external pull-down resistor is required.
July 2005	3.6	<ul style="list-style-type: none">Added pin C8 description to Table 29 and Table 31.
Aug 2005	3.7	<ul style="list-style-type: none">Corrected 25 MHz Clock Input Requirements in Table 13.
June 2006	3.8	<ul style="list-style-type: none">Corrected the FLSH_SO/LAN_DISABLE signal definition. If Flash functionality is not used then an external pull-up resistor is required.
June 2006	3.9	<ul style="list-style-type: none">Updated Table 13 "25 MHz Clock Input Requirements".
Aug 2006	4.0	<ul style="list-style-type: none">Updated Table 40 descriptions for pins A10, B10, and C9.Updated pinout descriptions from Tables 25 - 42 to match Figure 13.
Sept 2006	4.1	<ul style="list-style-type: none">Removed note "b" from Table 2 and note "a" from Tables 3 and 4. Moved the note following Table 5 before Table 3 "3.3V Supply Voltage Ramp".

Information in this document is provided in connection with Intel products. No license, express or implied, by estoppel or otherwise, to any intellectual property rights is granted by this document. Except as provided in Intel's Terms and Conditions of Sale for such products, Intel assumes no liability whatsoever, and Intel disclaims any express or implied warranty, relating to sale and/or use of Intel products including liability or warranties relating to fitness for a particular purpose, merchantability, or infringement of any patent, copyright or other intellectual property right. Intel products are not intended for use in medical, life saving, or life sustaining applications.

Intel may make changes to specifications and product descriptions at any time, without notice.

Designers must not rely on the absence or characteristics of any features or instructions marked "reserved" or "undefined." Intel reserves these for future definition and shall have no responsibility whatsoever for conflicts or incompatibilities arising from future changes to them.

The 82541ER Gigabit Ethernet Controller may contain design defects or errors known as errata which may cause the product to deviate from published specifications. Current characterized errata are available on request.

Contact your local Intel sales office or your distributor to obtain the latest specifications and before placing your product order.

Copies of documents which have an ordering number and are referenced in this document, or other Intel literature may be obtained by calling 1-800-548-4725 or by visiting Intel's website at <http://www.intel.com>.

Intel® is a trademark or registered trademark of Intel Corporation or its subsidiaries in the United States and other countries.

Copyright © Intel Corporation, 2006

*Third-party brands and names are the property of their respective owners.

Contents

1.0	Introduction	1
1.1	Document Scope.....	1
1.2	Reference Documents.....	2
1.3	Product Codes.....	2
1.4	Block Diagram	3
2.0	Product Code.....	5
3.0	Signal Descriptions.....	7
3.1	Signal Type Definitions.....	7
3.2	PCI Bus Interface Signals (56)	7
3.2.1	PCI Address, Data and Control Signals (44)	8
3.2.2	Arbitration Signals (2)	9
3.2.3	Interrupt Signal (1).....	9
3.2.4	System Signals (3)	9
3.2.5	Error Reporting Signals (2).....	10
3.2.6	Power Management Signals (2)	10
3.3	EEPROM and Serial FLASH Interface Signals (9).....	10
3.4	Miscellaneous Signals	11
3.4.1	LED Signals (4)	11
3.4.2	Other Signals (4)	11
3.5	PHY Signals	11
3.5.1	Crystal Signals (2)	11
3.5.2	Analog Signals (10)	12
3.6	Test Interface Signals (6)	12
3.7	Power Supply Connections	13
3.7.1	Digital and Analog Supplies	13
3.7.2	Grounds, Reserved Pins and No Connects	13
3.7.3	Voltage Regulation Control Signals (2)	13
4.0	Voltage, Temperature, and Timing Specifications	15
4.1	Absolute Maximum Ratings.....	15
4.2	Targeted Recommended Operating Conditions.....	15
4.2.1	General Operating Conditions.....	15
4.2.2	Voltage Ramp and Sequencing Recommendations.....	16
4.3	DC Specifications	18
4.4	AC Characteristics.....	21
4.5	Timing Specifications	23
4.5.1	PCI Bus Interface	23
4.5.1.1	PCI Bus Interface Clock	23
4.5.1.2	PCI/PCI-X Bus Interface Timing.....	24
4.5.2	Link Interface Timing	27
4.5.3	EEPROM Interface.....	27
5.0	Package and Pinout Information	29
5.1	Package Information	29
5.2	Thermal Specifications	31

5.3	Pinout Information	32
5.4	Visual Pin Assignments.....	42

Figures

1	82541ER Block Diagram	3
2	AC Test Loads for General Output Pins.....	23
3	PCI Clock Timing	23
4	PCI Bus Interface Output Timing Measurement	24
5	PCI Bus Interface Input Timing Measurement Conditions	25
6	TVAL (max) Rising Edge Test Load.....	25
7	TVAL (max) Falling Edge Test Load	26
8	TVAL (min) Test Load	26
9	TVAL Test Load (PCI 5 V Signaling Environment)	26
10	Link Interface Rise/Fall Timing.....	27
11	82541ER Mechanical Specifications.....	29
12	196 PBGA Package Pad Detail.....	30
13	Visual Pin Assignments.....	42

Tables

1	Absolute Maximum Ratings	15
2	Recommended Operating Conditions	15
3	3.3V Supply Voltage Ramp	16
4	1.8V Supply Voltage Ramp	16
5	1.2V Supply Voltage Ramp	17
6	DC Characteristics	18
7	Power Specifications - D0a	18
8	Power Specifications - D3cold	18
9	Power Specifications D(r) Uninitialized)	19
10	Power Specifications - Complete Subsystem	19
11	I/O Characteristics.....	20
12	AC Characteristics: 3.3 V Interfacing	21
13	25 MHz Clock Input Requirements	21
14	Reference Crystal Specification Requirements.....	22
15	Link Interface Clock Requirements	22
16	EEPROM Interface Clock Requirements	22
17	AC Test Loads for General Output Pins.....	22
18	PCI Bus Interface Clock Parameters	23
19	PCI Bus Interface Timing Parameters.....	24
20	PCI Bus Interface Timing Measurement Conditions	25
21	Rise and Fall Times	27
22	Link Interface Clock Requirements	27
23	Link Interface Clock Requirements	27
24	Thermal Characteristics	31
25	PCI Address, Data and Control Signals	32
26	PCI Arbitration Signals	32
27	Interrupt Signals	32
28	System Signals	32
29	Error Reporting Signals.....	33
30	Power Management Signals	33
31	Serial EEPROM Interface Signals.....	33



32	Serial FLASH Interface Signals	33
33	LED Signals.....	33
34	Other Signals.....	33
35	IEEE Test Signals	34
36	PHY Signals	34
37	Test Interface Signals.....	34
38	Digital Power Signals	34
39	Analog Power Signals	35
40	Grounds and No Connect Signals.....	35
41	Voltage Regulation Control Signals.....	35
42	Signal Names in Pin Order	36

82541ER Gigabit Ethernet Controller



Note: This page is intentionally blank.

1.0 Introduction

The Intel® 82541ER Gigabit Ethernet is a single, compact component with an integrated Gigabit Ethernet Media Access Control (MAC) and physical layer (PHY) functions. For embedded communication and network devices such as web kiosks, and Point-of-Sale terminal designs with critical space constraints, the Intel 82541ER allows for a Gigabit Ethernet implementation in a very small area that is footprint compatible with current generation 10/100 Mbps Fast Ethernet designs.

The Intel® 82541ER integrates fourth generation gigabit MAC design with fully integrated, physical layer circuitry to provide a standard IEEE 802.3 Ethernet interface for 1000BASE-T, 100BASE_TX, and 10BASE-T applications (802.3, 802.3u, and 802.3ab). The controller is capable of transmitting and receiving data at rates of 1000 Mbps, 100 Mbps, or 10 Mbps. In addition to managing MAC and PHY layer functions, the controller provides a 32-bit wide direct Peripheral Component Interconnect (PCI) 2.3 compliant interface capable of operating at 33 or 66 MHz.

The 82541ER Architecture is designed for high performance and low memory latency. Wide internal data paths eliminate performance bottlenecks by efficiently handling large address and data words. The 82541ER controller includes advanced interrupt handling features to limit PCI bus traffic and a PCI interface that maximizes efficient bus usage. The 82541ER uses efficient ring buffer descriptor data structures, with up to 64 packet descriptors cached on chip. A large 64 KByte on-chip packet buffer maintains superior performance as available PCI bandwidth changes. In addition, using hardware acceleration, the controller offloads tasks from the host controller, such as TCP/UDP/IP checksum calculations and TCP segmentation.

The 82541ER is packaged in a 15 mm X 15 mm 196-ball grid array and is pin compatible with the 82559ER/82551ER 10/100 Mbps Fast Ethernet Multifunction PCI/CardBus Controller, 82562EZ/82562EX Platform LAN Connect devices, the 82540EM Gigabit Ethernet Controller and the 82540EP Gigabit Ethernet Controller.

1.1 Document Scope

This document contains datasheet specifications for the 82541ER Gigabit Ethernet Controller, including signal descriptions, DC and AC parameters, packaging data, and pinout information.



1.2 Reference Documents

This document assumes that the designer is acquainted with high-speed design and board layout techniques. The following documents provide additional information:

- 825462EZ(EX)/82551ER(IT) & 82541ER Combined Footprint LOM Design Guide. Intel Corporation.
- 82547GI(EI)/82541(PI/GIEI) & 82541ER EEPROM Map and Programming Information Guide. Intel Corporation.
- PCI Local Bus Specification, Revision 2.3. PCI Special Interest Group.
- PCI Bus Power Management Interface Specification, Revision 1.1. PCI Special Interest Group.
- IEEE Standard 802.3, 2003 Edition. Incorporates various IEEE standards previously published separately. Institute of Electrical and Electronics Engineers (IEEE).
- Intel Ethernet Controllers Timing Device Selection Guide. Intel Corporation.
- PCI Mobile Design Guide, Revision 1.1. PCI Special Interest Group.

Software driver developers should contact their local Intel representatives for programming information.

1.3 Product Codes

The product ordering codes are:

- GD82541ER
- LU82541ER

1.4 Block Diagram

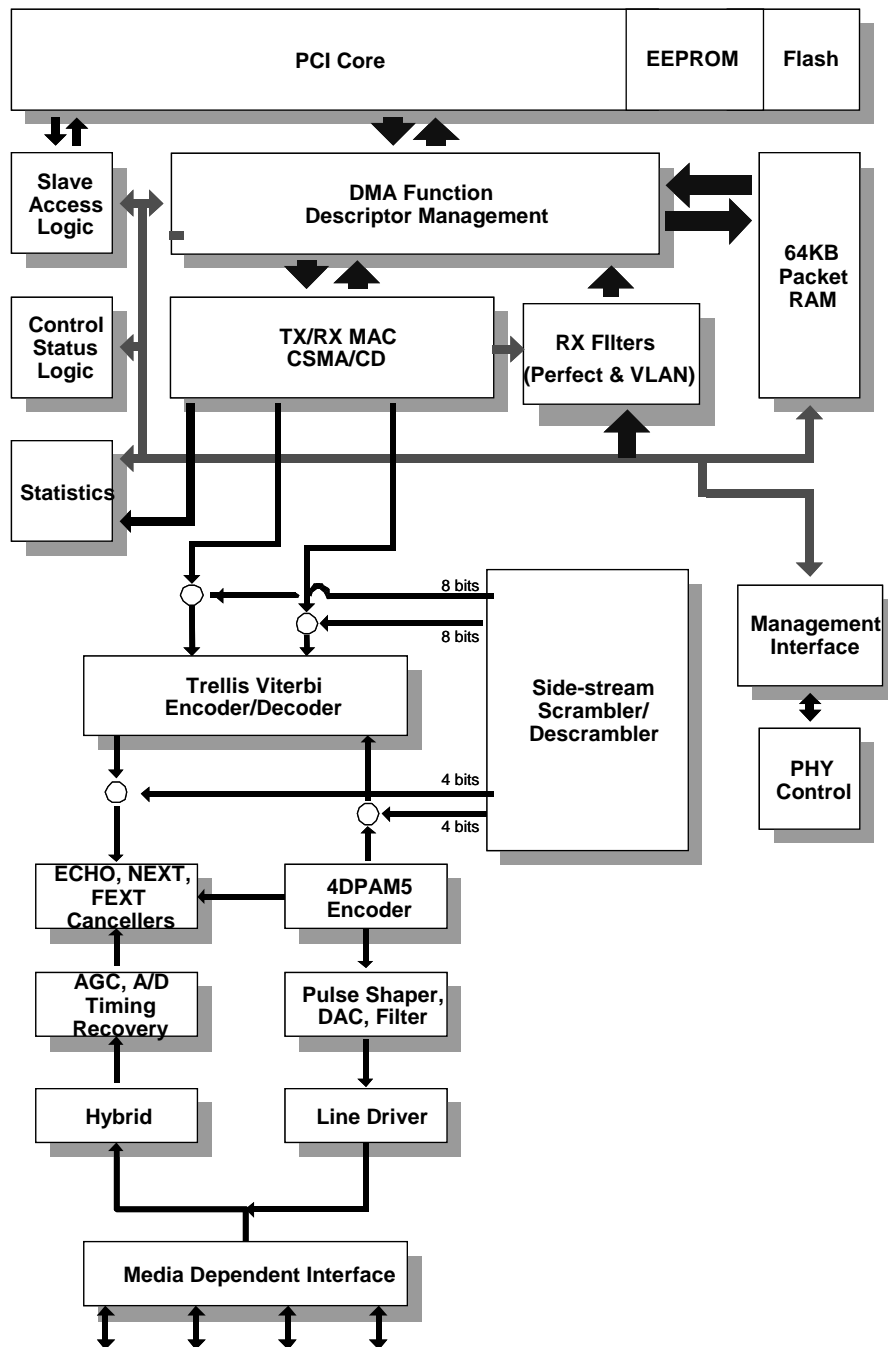

Figure 1. 82541ER Block Diagram

82541ER Gigabit Ethernet Controller



Note: This page intentionally left blank.



2.0 Product Code

The product code for the 82541ER Gigabit Ethernet Controller is: GD82541ER.

82541ER Gigabit Ethernet Controller



Note: This page intentionally left blank.

3.0 Signal Descriptions

3.1 Signal Type Definitions

The signals of the 82541ER controller are electrically defined as follows:

Name	Definition
I	Input. Standard input only digital signal.
O	Output. Standard output only digital signal.
TS	Tri-state. Bi-directional tri-state digital input/output signal.
STS	Sustained Tri-state. An active low tri-state signal owned and driven by only one agent at a time. The agent that drives an STS pin low must drive it high for at least one clock before letting it float. A new agent cannot start driving an STS signal any sooner than one clock after the previous owner tri-states it. A pullup is required to sustain the inactive state until another agent drives it, and must be provided by the central resource.
OD	Open Drain. Wired-OR with other agents. The signaling agent asserts the OD signal, but the signal is returned to the inactive state by a weak pull-up resistor. The pull-up resistor may require two or three clock periods to fully restore the signal to the de-asserted state.
A	Analog. PHY analog data signal.
P	Power. Power connection, voltage reference, or other reference connection.

3.2 PCI Bus Interface Signals (56)

When the Reset signal (RST#) is asserted, the 82541ER will not drive any PCI output or bi-directional pins.

3.2.1 PCI Address, Data and Control Signals (44)

Symbol	Type	Name and Function
AD[31:0]	TS	<p>Address and Data. Address and data signals are multiplexed on the same PCI pins. A bus transaction includes an address phase followed by one or more data phases.</p> <p>The address phase is the clock cycle when the Frame signal (FRAME#) is asserted low. During the address phase AD[31:0] contain a physical address (32 bits). For I/O, this is a byte address, and for configuration and memory, a DWORD address. The 82541ER device uses little endian byte ordering.</p> <p>During data phases, AD[7:0] contain the least significant byte (LSB) and AD[31:24] contain the most significant byte (MSB).</p>
C/BE#[3:0]	TS	<p>Bus Command and Byte Enables. Bus command and byte enable signals are multiplexed on the same PCI pins. During the address phase of a transaction, C/BE#[3:0] define the bus command. In the data phase, C/BE#[3:0] are used as byte enables. The byte enables are valid for the entire data phase and determine which byte lanes contain meaningful data.</p> <p>C/BE#[0] applies to byte 0 (LSB) and C/BE#[3] applies to byte 3 (MSB).</p>
PAR	TS	<p>Parity. The Parity signal is issued to implement even parity across AD[31:0] and C/BE#[3:0]. PAR is stable and valid one clock after the address phase. During data phases, PAR is stable and valid one clock after either IRDY# is asserted on a write transaction or TRDY# is asserted after a read transaction. Once PAR is valid, it remains valid until one clock after the completion of the current data phase.</p> <p>When the 82541ER controller is a bus master, it drives PAR for address and write data phases, and as a slave device, drives PAR for read data phases.</p>
FRAME#	STS	<p>Cycle Frame. The Frame signal is driven by the 82541ER device to indicate the beginning and length of a bus transaction.</p> <p>While FRAME# is asserted, data transfers continue. FRAME# is de-asserted when the transaction is in the final data phase.</p>
IRDY#	STS	<p>Initiator Ready. Initiator Ready indicates the ability of the 82541ER controller (as a bus master device) to complete the current data phase of the transaction. IRDY# is used in conjunction with the Target Ready signal (TRDY#). The data phase is completed on any clock when both IRDY# and TRDY# are asserted.</p> <p>During the write cycle, IRDY# indicates that valid data is present on AD[31:0]. For a read cycle, it indicates the master is ready to accept data. Wait cycles are inserted until both IRDY# and TRDY# are asserted together. The 82541ER controller drives IRDY# when acting as a master and samples it when acting as a slave.</p>
TRDY#	STS	<p>Target Ready. The Target Ready signal indicates the ability of the 82541ER controller (as a selected device) to complete the current data phase of the transaction. TRDY# is used in conjunction with the Initiator Ready signal (IRDY#). A data phase is completed on any clock when both TRDY# and IRDY# are sampled asserted.</p> <p>During a read cycle, TRDY# indicates that valid data is present on AD[31:0]. For a write cycle, it indicates the target is ready to accept data. Wait cycles are inserted until both IRDY# and TRDY# are asserted together. The 82541ER device drives TRDY# when acting as a slave and samples it when acting as a master.</p>
STOP#	STS	<p>Stop. The Stop signal indicates the current target is requesting the master to stop the current transaction. As a slave, the 82541ER controller drives STOP# to request the bus master to stop the transaction. As a master, the 82541ER controller receives STOP# from the slave to stop the current transaction.</p>

Symbol	Type	Name and Function
IDSEL#	I	Initialization Device Select. The Initialization Device Select signal is used by the 82541ER as a chip select signal during configuration read and write transactions.
DEVSEL#	STS	Device Select. When the Device Select signal is actively driven by the 82541ER, it signals notifies the bus master that it has decoded its address as the target of the current access. As an input, DEVSEL# indicates whether any device on the bus has been selected.
VIO	P	VIO. The VIO signal is a voltage reference for the PCI interface (3.3 V or 5 V PCI signaling environment). It is used as the clamping voltage. Note: VIO should be connected to 3.3V Aux or 5V Aux in order to be compatible with the pull-up clamps specification.

3.2.2 Arbitration Signals (2)

Symbol	Type	Name and Function
REQ#	TS	Request Bus. The Request Bus signal is used to request control of the bus from the arbiter. This signal is point-to-point.
GNT#	I	Grant Bus. The Grant Bus signal notifies the 82541ER that bus access has been granted. This is a point-to-point signal.

3.2.3 Interrupt Signal (1)

Symbol	Type	Name and Function
INTA#	TS	Interrupt A. Interrupt A is used to request an interrupt of the 82541ER. It is an active low, level-triggered interrupt signal.

3.2.4 System Signals (3)

Symbol	Type	Name and Function
CLK	I	PCI Clock. The PCI Clock signal provides timing for all transactions on the PCI bus and is an input to the 82541ER device. All other PCI signals, except the Interrupt A (INTA#) and PCI Reset signal (RST#), are sampled on the rising edge of CLK. All other timing parameters are defined with respect to this edge.
M66EN	I	66 MHz Enable. M66EN indicates whether the system bus is enabled for 66MHz
RST#	I	PCI Reset. When the PCI Reset signal is asserted, all PCI output signals are floated and all input signals are ignored. Most of the internal state of the 82541ER is reset on the de-assertion (rising edge) of RST#.

3.2.5 Error Reporting Signals (2)

Symbol	Type	Name and Function
SERR#	OD	System Error. The System Error signal is used by the 82541ER controller to report address parity errors. SERR# is open drain and is actively driven for a single PCI clock when reporting the error.
PERR#	STS	Parity Error. The Parity Error signal is used by the 82541ER controller to report data parity errors during all PCI transactions except by a Special Cycle. PERR# is sustained tri-state and must be driven active by the 82541ER controller two data clocks after a data parity error is detected. The minimum duration of PERR# is one clock for each data phase a data parity error is present.

3.2.6 Power Management Signals (2)

Symbol	Type	Name and Function
LAN_PWR_GOOD	I	Power Good (Power-on Reset). The Power Good signal is used to indicate that stable power is available for the 82541ER. When the signal is low, the 82541ER holds itself in reset state and floats all PCI signals.
AUX_PWR	I	Auxiliary Power. If the Auxiliary Power signal is high, then auxiliary power is available and the 82541ER device should support the D3cold power state.

3.3 EEPROM and Serial FLASH Interface Signals (9)

Symbol	Type	Name and Function
EEMODE	I	EEPROM Mode. The EEPROM Mode pin is used to select the interface and source of the EEPROM used to initialize the device. For a Microwire* EEPROM on the standard EEPROM pins, tie this pin to ground with a 100 Ω pull-down resistor. For a Serial Peripheral Interface (SPI*) EEPROM, leave this pin disconnected.
EEDI	O	EEPROM Data Input. The EEPROM Data Input pin is used for output to the memory device.
EEDO	I	EEPROM Data Output. The EEPROM Data Output pin is used for input from the memory device. The EEDO includes an internal pull-up resistor. Note: Voltage for EEDO must be less than 0.7 V.
EECS	O	EEPROM Chip Select. The EEPROM Chip Select signal is used to enable the device.
EESK	O	EEPROM Serial Clock. The EEPROM Shift Clock provides the clock rate for the EEPROM interface, which is approximately 1 MHz for Microwire* and 2 MHz for SPI.
FLSH_CE#	O	Flash Chip Enable Output. Used to enable FLASH device.
FLSH_SCK	O	Flash Serial Clock Output. The clock rate of the serial FLASH interface is approximately 1 MHz.
FLSH_SI	O	Flash Serial Data Input. This pin is an output to the memory device.
FLSH_SO/ LAN_DISABLE#	I	Flash Serial Data Output / LAN Disable. This pin is an input from the Flash memory. Alternatively, the pin can be used to disable the LAN port from a system General Purpose Input Output (GPIO) port. It has an internal pullup device. If the 82541ER is not using Flash functionality, the pin should be connected to an external pull-up resistor. If this pin is used as LAN_DISABLE#, the device goes to low power state and the LAN port is disabled when this pin is sampled low on rising edge of PCI reset.

3.4 Miscellaneous Signals

3.4.1 LED Signals (4)

Symbol	Type	Name and Function
LINK_LED#	O	LED0 / LINK Up. Programmable LED indication. Defaults to indicate link connectivity.
ACTIVITY#	O	LED1 / Activity. Programmable LED indication. Defaults to flash to indicate transmit or receive activity.
LINK100#	O	LED2 / LINK 100. Programmable LED indication. Defaults to indicate link at 100 Mbps.
LINK1000#	O	LED3 / LINK 1000. Programmable LED indication. Defaults to indicate link at 1000 Mbps.

3.4.2 Other Signals (4)

Symbol	Type	Name and Function
SDP[3:0]	TS	Software Defined Pin. The Software Defined Pins are reserved and programmable with respect to input and output capability. These default to input signals upon power-up but may be configured differently by the EEPROM. The upper four bits may be mapped to the General Purpose Interrupt bits if they are configured as input signals.

3.5 PHY Signals

3.5.1 Crystal Signals (2)

Symbol	Type	Name and Function
XTAL1	I	Crystal One. The Crystal One pin is a 25 MHz +/- 50 ppm input signal. It should be connected to a crystal, and the other end of the crystal should connect to XTAL2.
XTAL2	O	Crystal Two. Crystal Two is the output of an internal oscillator circuit used to drive a crystal into oscillation.

3.5.2 Analog Signals (10)

Symbol	Type	Name and Function
MDI[0]+/-	A	Media Dependent Interface [0]. 1000BASE-T: In MDI configuration, MDI[0]+/- corresponds to BI_DA+/-, and in MDI-X configuration, MDI[0]+/- corresponds to BI_DB+/-. 100BASE_TX: In MDI configuration, MDI[0]+/- is used for the transmit pair, and in MDI-X configuration, MDI[0]+/- is used for the receive pair. 10BASE-T: In MDI configuration, MDI[0]+/- is used for the transmit pair, and in MDI-X configuration, MDI[0]+/- is used for the receive pair.
MDI[1]+/-	A	Media Dependent Interface [1]. 1000BASE-T: In MDI configuration, MDI[1]+/- corresponds to BI_DB+/-, and in MDI-X configuration, MDI[1]+/- corresponds to BI_DA+/-. 100BASE_TX: In MDI configuration, MDI[1]+/- is used for the receive pair, and in MDI-X configuration, MDI[1]+/- is used for the transmit pair. 10BASE-T: In MDI configuration, MDI[1]+/- is used for the receive pair, and in MDI-X configuration, MDI[1]+/- is used for the transmit pair.
MDI[2]+/-	A	Media Dependent Interface [2]. 1000BASE-T: In MDI configuration, MDI[2]+/- corresponds to BI_DC+/-, and in MDI-X configuration, MDI[2]+/- corresponds to BI_DD+/-. 100BASE_TX: Unused. 10BASE-T: Unused.
MDI[3]+/-	A	Media Dependent Interface [3]. 1000BASE-T: In MDI configuration, MDI[3]+/- corresponds to BI_DC+/-, and in MDI-X configuration, MDI[3]+/- corresponds to BI_DD+/-. 100BASE_TX: Unused. 10BASE-T: Unused.
IEEE_TEST-	A	IEEE test pin output minus. Used to gain access to the internal PHY clock for 1000BASE-T IEEE physical layer conformance testing.
IEEE_TEST+	A	Analog test pin output plus. Used to gain access to the internal PHY clock for 1000BASE-T IEEE physical layer conformance testing.

3.6 Test Interface Signals (6)

Symbol	Type	Name and Function
TEST	I	Test Enable. Enables test mode. Normal mode: connect to VSS.
JTAG_TCK	I	JTAG Test Access Port Clock.
JTAG_TDI	I	JTAG Test Access Port Data In.
JTAG_TDO	O	JTAG Test Access Port Data Out.
JTAG_TMS	I	JTAG Test Access Port Mode Select.
JTAG_TRST#	I	JTAG Test Access Port Reset. This is an active low reset signal for JTAG. To disable the JTAG interface, this signal should be terminated using a 100 Ω pull-down resistor to ground. It must not be left unconnected.

3.7 Power Supply Connections

3.7.1 Digital and Analog Supplies

Symbol	Type	Name and Function
3.3V	P	3.3 V I/O Power Supply.
Analog_1.8V	P	1.8V Analog Power Supply.
CLKR_1.8V	P	1.8V analog power supply for the clock recovery.
XTAL_1.8V	P	Input power for the XTAL regulator.
1.2V	P	1.2V Power supply. This is for analog and digital circuits.
Analog_1.2V	P	1.2V Analog Power Supply.
PLL_1.2V	P	Input power for the ICS regulator.

3.7.2 Grounds, Reserved Pins and No Connects

Symbol	Type	Name and Function
VSS	P	Ground.
AVSS	P	Shared analog Ground.
RSVD_VSS	P	Reserved Ground. This pin is reserved by Intel and may have factory test functions. For normal operation, connect to ground.
RSVD_NC	P	Reserved No connect. This pin is reserved by Intel and may have factory test functions. For normal operation, do not connect any circuit to these pins. Do not connect pull-up or pull-down resistors.
NC	P	No Connect. This pin is not connected internally.
RSVD_VCC	P	Reserved VCC. This pin is reserved by Intel and may have factory test functions. For normal operation, connect to VCC through a 1K pull-up resistor

3.7.3 Voltage Regulation Control Signals (2)

Symbol	Type	Name and Function
CTRL12	A	1.2V Control. LDO voltage regulator output to drive external PNP pass transistor. If 1.2V is already present in the system, leave output unconnected. To achieve optimal D3 power consumption, leave the output unconnected and use a high-efficiency external switching regulator.
CTRL18	A	1.8V Control. LDO voltage regulator output to drive external PNP pass transistor. If 1.8V is already present in the system, leave output unconnected. To achieve optimal D3 power consumption, leave the output unconnected and use a high-efficiency external switching regulator.

82541ER Gigabit Ethernet Controller



Note: This page intentionally left blank.

4.0 Voltage, Temperature, and Timing Specifications

4.1 Absolute Maximum Ratings

Table 1. Absolute Maximum Ratings^a

Symbol	Parameter	Min	Max	Unit
VDD (3.3)	DC supply voltage on 3.3 V pins with respect to VSS	VSS - 0.5	4.6	V
VDD (1.8)	DC supply voltage on 1.8 V pins with respect to VSS	VSS - 0.5	2.5 or VDD (1.8) + 0.5 ^b	V
VDD (1.2)	DC supply voltage on 1.2V pins with respect to VSS	VSS - 0.5	1.7 or VDD (1.2) + 0.5 ^c	V
VDD	DC supply voltage	VSS - 0.5	4.6	V
VI / VO	LVTTTL input voltage	VSS - 0.5	4.6 ^d	V
IO	Output current		40	mA
TSTG	Storage temperature range	-40	125	°C
	ESD per MIL_STD-883 Test Method 3015, Specification 2001V Latchup Over/Undershoot: 150 mA, 125 C		VDD overstress: VDD (3.3) * 7.2	V

- a. Maximum ratings are referenced to ground (VSS). Permanent device damage is likely to occur if the ratings in this table are exceeded. These values should not be used as the limits for normal device operations.
- b. The maximum value is the lesser value of 2.5V or VDD (2.5) + 0.5 V. This specification applies to biasing the device to a steady state for an indefinite duration.
- c. The maximum value is the lesser value of 1.7 V or VDD (2.5) + 0.5 V.
- d. The maximum value must also be less than VIO.

4.2 Targeted Recommended Operating Conditions

4.2.1 General Operating Conditions

Table 2. Recommended Operating Conditions (Sheet 1 of 2)^a

Symbol	Parameter	Min	Max	Unit
VDD (3.3)	DC supply voltage on 3.3 V pins	3.0	3.6	V
VDD (1.8)	DC supply voltage on 1.8 V pins	1.71 ^b	1.89 ^c	V
VDD (1.2)	DC supply voltage on 1.2 V pins	1.14 ^d	1.26 ^e	V
VIO	PCI bus reference voltage	3.0	5.25	V
tR / tF	Input rise/fall time (normal input)	0	200	ns

Table 2. Recommended Operating Conditions (Sheet 2 of 2)^a

Symbol	Parameter	Min	Max	Unit
tr/ff	input rise/fall time (Schmitt input)	0	10	ms
T _A	Operating temperature range (ambient)	0	70	°C
T _J	Junction temperature		≤125	°C

- a. Sustained operation of the device at conditions exceeding these values, even if they are within the absolute maximum rating limits, might result in permanent damage.
- b. The value listed in this table is for external voltage regulation. If the internal voltage regulator is used, the minimum value is 1.67 V.
- c. The value listed in this table is for external voltage regulation. If the internal voltage regulator is used, the maximum value is 1.926 V.
- d. The value listed in this table is for external voltage regulation. If the internal voltage regulator is used, the minimum value is 1.12 V.
- e. The value listed in this table is for external voltage regulation. If the internal voltage regulator is used, the maximum value is 1.284 V.

4.2.2 Voltage Ramp and Sequencing Recommendations

Note: In any case or time period (greater than 1 ns), the supply voltage should comply with 3.3V > 1.8V > 1.2V. This is important to avoid stress in the ESD protection circuits. After 3.3V reaches 10% of its final value, all voltage rails (1.8V and 1.2V) have 150 ms to reach their final operating values.

Table 3. 3.3V Supply Voltage Ramp

Parameter	Description	Min	Max	Unit
Rise Time	Time from 10% to 90% mark	0.1	100	ms
Monotonicity	Voltage dip allowed in ramp		0	mV
Slope	Ramp rate at any time between 10% to 90%		28800	V/s
Operational Range	Voltage range for normal operating conditions	3	3.6	V
Ripple	Maximum voltage ripple at a bandwidth equal to 50 MHz		70	mV
Overshoot	Maximum voltage allowed		4	V

Table 4. 1.8V Supply Voltage Ramp

Symbol	Parameter	Min	Max	Unit
Rise Time	Time from 10% to 90% mark	0.1	100	ms
Monotonicity	Voltage dip allowed in ramp		0	mV
Slope	Ramp rate at any time between 10% to 90%		57600	V/s
Operational Range	Voltage range for normal operating conditions (PNP's) ^a	1.674	1.89	V
Operational Range	Voltage range for normal operating conditions (PNP's)	-7	5	%
Operational Range	Voltage range for normal operating conditions (external regulator)	1.71	1.89	V
Operational Range	Voltage range for normal operating conditions (external regulator)	-5	5	%

Table 4. 1.8V Supply Voltage Ramp

Ripple	Maximum voltage ripple at a bandwidth equal to 50 MHz		20	mV
Overshoot	Maximum voltage allowed		2.2	V
Output Capacitance	Capacitance range when using PNP circuit	4.7	20	μF
Input Capacitance	Capacitance range when using PNP circuit	4.7	20	μF
Capacitance ESR	Equivalent series resistance of output capacitance ^b	5	100	mΩ
Ictrl_18	Maximum output current rating to CTRL18		20	mA

- a. Operating with an internal regulator (PNP) supports a wider tolerance output voltage due to process tracking.
b. Tantalum capacitors must not be used.

Table 5. 1.2V Supply Voltage Ramp

Symbol	Parameter	Min	Max	Unit
Rise Time	Time from 10% to 90% mark	0.025		ms
Monotonicity	Voltage dip allowed in ramp		0	mV
Slope	Ramp rate at any time between 10% to 90%		38400	V/s
Operational Range	Voltage range for normal operating conditions (PNP's) ^a	1.116	1.26	V
Operational Range	Voltage range for normal operating conditions (PNP's)	-7	5	%
Operational Range	Voltage range for normal operating conditions (external regulator)	1.14	1.26	V
Operational Range	Voltage range for normal operating conditions (external regulator)	-5	5	%
Ripple	Maximum voltage ripple at a bandwidth equal to 50 MHz		20	mV
Overshoot	Maximum voltage allowed		1.45	V
Output Capacitance	Capacitance range when using PNP circuit	4.7	20	μF
Input Capacitance	Capacitance range when using PNP circuit	4.7	20	μF
Capacitance ESR	Equivalent series resistance of output capacitance ^b	5	100	mΩ
Ictrl_12	Maximum output current rating to CTRL_12		20	mA

- a. Operating with an internal regulator (PNP) supports a wider tolerance output voltage due to process tracking.
b. Tantalum capacitors must not be used.

4.3 DC Specifications

Table 6. DC Characteristics

Symbol	Parameter	Condition	Min	Typ	Max	Units
VDD (3.3)	DC supply voltage on 3.3 V pins		3.00	3.3	3.60	V
VDD (1.8)	DC supply voltage on 1.8 V pins		1.71 ^a	1.8	1.89 ^b	V
VDD (1.2)	DC supply voltage on 1.2 V pins		1.14 ^c	1.2	1.26 ^d	V

- a. The value listed in this table is for external voltage regulation. If the internal voltage regulator is used, the minimum value is 1.67 V.
- b. The value listed in this table is for external voltage regulation. If the internal voltage regulator is used, the maximum value is 1.926 V.
- c. The value listed in this table is for external voltage regulation. If the internal voltage regulator is used, the minimum value is 1.12 V.
- d. The value listed in this table is for external voltage regulation. If the internal voltage regulator is used, the maximum value is 1.284 V.

Table 7. Power Specifications - D0a

	D0a							
	unplugged no link		@10 Mbps		@100 Mbps		@ 1000 Mbps	
	Typ Icc (mA) ^a	Max Icc (mA) ^b	Typ Icc (mA) ^a	Max Icc (mA) ^b	Typ Icc (mA) ^a	Max Icc (mA) ^b	Typ Icc (mA) ^a	Max Icc (mA) ^b
3.3V	3	5	5	10	13	15	30	40
1.8V	14	15	85	85	110	115	315	320
1.2V	30	35	85	90	90	100	380	400
Total Device Power	75 mW		270 mW		355 mW		1.1 W	1.2 W

- a. Typical conditions: operating temperature (T_A) = 25 C, nominal voltages, moderate network traffic at full duplex, and PCI 33 MHz system interface.
- b. Maximum conditions: minimum operating temperature (T_A) values, maximum voltage values, continuous network traffic at full duplex, and PCI 33 MHz system interface.

Table 8. Power Specifications - D3cold

	D3cold - wake-up enabled ^a						D3cold-wake disabled	
	unplugged link		@10 Mbps		@100 Mbps			
	Typ Icc (mA) ^b	Max Icc (mA) ^c	Typ Icc (mA) ^a	Max Icc (mA) ^b	Typ Icc (mA) ^a	Max Icc (mA) ^b	Typ Icc (mA) ^a	Max Icc (mA) ^b
3.3V	2	3	2	3	2	3	4	5

Table 8. Power Specifications - D3cold

	D3cold - wake-up enabled ^a						D3cold-wake disabled	
	unplugged link		@10 Mbps		@100 Mbps			
	Typ Icc (mA) ^b	Max Icc (mA) ^c	Typ Icc (mA) ^a	Max Icc (mA) ^b	Typ Icc (mA) ^a	Max Icc (mA) ^b	Typ Icc (mA) ^a	Max Icc (mA) ^b
1.8V	14	15	20	25	110	115	1	2
1.2V	21	25	30	35	80	85	7	10
Total Device Power	60 mW		80 mW		305 mW		25 mW	

- a. The power consumption for 1000 Mbps is not shown since the controller moves to the 10/100 Mbps mode before going into the D3 state to conserve power.
- b. Typical conditions: operating temperature (T_A) = 25 C, nominal voltages, moderate network traffic at full duplex, and PCI 33 MHz system interface.
- c. Maximum conditions: minimum operating temperature (T_A) values, maximum voltage values, continuous network traffic at full duplex, and PCI 33 MHz system interface.

Table 9. Power Specifications D(r) Uninitialized

	D(r) Uninitialized (FLSH_SO/LAN_DISABLE # = 0)	
	Typ Icc (mA)	Max Icc (mA)
3.3V	5	10
1.8V	1	2
1.2V	12	15
Total Device Power	35 mW	

Table 10. Power Specifications - Complete Subsystem

	Complete Subsystem (Reference Design) Including Magnetics, LED, Regulator Circuits									
	D3cold - wake disabled		D3cold wake-enabled @ 10 Mbps		D0 @10 Mbps active		D0 @100 Mbps active		D0 @ 1000 Mbps active	
	Typ Icc (mA) ^a	Max Icc (mA) ^b	Typ Icc (mA) ^a	Max Icc (mA) ^b	Typ Icc (mA) ^a	Max Icc (mA) ^b	Typ Icc (mA) ^a	Max Icc (mA) ^b	Typ Icc (mA) ^a	Max Icc (mA) ^b
3.3 V	4	5	7	10			12	15	33	45

Table 10. Power Specifications - Complete Subsystem

	Complete Subsystem (Reference Design) Including Magnetics, LED, Regulator Circuits									
	D3cold - wake disabled		D3cold wake-enabled @ 10 Mbps		D0 @10 Mbps active		D0 @100 Mbps active		D0 @ 1000 Mbps active	
	Typ Icc (mA) ^a	Max Icc (mA) ^b	Typ Icc (mA) ^a	Max Icc (mA) ^b	Typ Icc (mA) ^a	Max Icc (mA) ^b	Typ Icc (mA) ^a	Max Icc (mA) ^b	Typ Icc (mA) ^a	Max Icc (mA) ^b
1.8 V	1	7	2	30			35	135	140	410
1.2 V		7	10	30			35	80	85	380
Subsystem 3.3V Current		10		40				120		710

- a. Typical conditions: operating temperature (T_A) = 25 C, nominal voltages, moderate network traffic at full duplex, and PCI 33 MHz system interface.
- b. Maximum conditions: minimum operating temperature (T_A) values, maximum voltage values, continuous network traffic at full duplex, and PCI 33 MHz system interface.

Table 11. I/O Characteristics (Sheet 1 of 2)

Symbol	Parameter	Condition	Min	Typ	Max	Units
VIH	Input high voltage	3.3 V PCI	$0.5 * V_{DD}(3.3)$		$V_{DD}(3.3)$ or VIO	V
VIL	Input low voltage	3.3 V PCI ^a	VSS		$0.3 * V_{DD}(3.3)$	V
IIN	Input current	$0 < V_{IN} < V_{DD}(3.3)$	-10		10	μ A
	Input with pull-down resistor (50 K Ω)	$V_{IN} = V_{DD}(3.3)$	28		191	
	Inputs with pull-up resistor (50 K Ω)	$V_{IN} = V_{SS}$	-28		-191	
IOL	Output low current	3.3 V PCI			2.09	mA
		$0 \leq V_{OUT} \leq 3.6V$			$100 * V_{OUT}$	
		$0 \leq V_{OUT} \leq 1.3V$	$48 * V_{OUT}$			
		$1.3V \leq V_{OUT} \leq 3.6V$	$5.7 * V_{OUT} + 55$			
IOH	Output high current:	$0 \leq (V_{DD} - V_{OUT}) \leq 3.6V$			$-74 * (V_{DD} - V_{OUT})$	mA
		$0 \leq (V_{DD} - V_{OUT}) \leq 1.2V$	$-32 * (V_{DD} - V_{OUT})$			
		$1.2V \leq (V_{DD} - V_{OUT}) \leq 1.9V$	$-11 * (V_{DD} - V_{OUT}) - 25.2$			
		$1.9V \leq (V_{DD} - V_{OUT}) \leq 3.6V$	$-1.8 * (V_{DD} - V_{OUT}) - 42.7$			
VOH	Output high voltage: 3.3 V PCI	IOH = -500 mA	$0.9 * V_{DD}(3.3)$			V

Table 11. I/O Characteristics (Sheet 2 of 2) (Continued)

Symbol	Parameter	Condition	Min	Typ	Max	Units
VOL	Output low voltage: 3.3 V PCI	IOL = 1500 mA			0.1 * VDD(3.3)	V
IOZ	Off-state output leakage current	VO = VDD or VSS	-10		10	μA
IOS	Output short circuit current				-250	mA
CIN	Input capacitance ^b	Input and bi-directional buffers		8		pF

a. The maximum VIL is 0.6 V for the following Pins: A13, C5, C8, J4, L7, L12, L13, M8, M12, M13, N10, N11, N13, N14, P9, and P13.
b. V_{DD} (3.3) = 0 V; T_A = 25 C; f = 1 Mhz

4.4 AC Characteristics

Table 12. AC Characteristics: 3.3 V Interfacing

Symbol	Parameter	Min	Typ	Max	Unit
PCICLK	Clock frequency in PCI mode			66	MHz

Table 13. 25 MHz Clock Input Requirements

Symbol	Parameter	Specifications			Units
		Min	Typ	Max	
f0	Frequency		25		MHz
df0	Frequency variation	-50		+30	ppm
Dc	Duty cycle	40		60	%
tr	Rise time			5	ns
tf	Fall time			5	ns
Jptp	Clock jitter (peak-to-peak) ^a			250	ps
Cin	Input capacitance		20		pF
T	Operating temperature			70	° C
Aptp	Input clock amplitude (peak-to-peak)	1.0	1.2	1.3	V
Vcm	Clock common mode		0.6		V

a. Clock jitter is defined according to the recommendations of part 40.6.1.2.5 IEEE 1000BASE-T Standard (at least 10⁵ clock edges, filtered by HPF with cut off frequency 5000 Hz).

Table 14. Reference Crystal Specification Requirements

Specification	Value
Vibrational Mode	Fundamental
Nominal Frequency	25.000 MHz at 25° C
Frequency Tolerance	±30 ppm
Temperature Stability	±30 ppm at 0° C to 70° C
Calibration Mode	Parallel
Load Capacitance	20 pF to 24 pF
Shunt Capacitance	6 pF maximum
Series Resistance, Rs	50 W maximum
Drive Level	0.5 mW maximum
Aging	±5.0 ppm per year maximum
Insulation Resistance	500 MΩ at DC 100 V

Table 15. Link Interface Clock Requirements

Symbol	Parameter	Min	Typ	Max	Unit
fGTX ^a	GTX_CLK frequency		125		MHz

a. GTX_CLK is used externally for test purposes only.

Table 16. EEPROM Interface Clock Requirements

Symbol	Parameter	Min	Typ	Max	Unit
fSK	Microwire EEPROM Clock			1	MHz
	SPI EEPROM Clock			2	MHz

Table 17. AC Test Loads for General Output Pins

Symbol	Signal Name	Value	Units
CL	TDO	10	pF
CL	SDP[3:0]	16	pF
CL	EEDI, EESK	18	pF
CL	LED[3:0]	20	pF

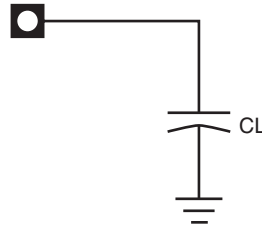

Figure 2. AC Test Loads for General Output Pins

4.5 Timing Specifications

4.5.1 PCI Bus Interface

4.5.1.1 PCI Bus Interface Clock

Table 18. PCI Bus Interface Clock Parameters

Symbol	Parameter ^a	PCI 66 MHz		PCI 33 MHz		Units
		Min	Max	Min	Max	
TCYC	CLK cycle time	15	30	30		ns
TH	CLK high time	6		11		ns
TL	CLK low time	6		11		ns
	CLK slew rate	1.5	4	1	4	V/ns
	RST# slew rate ^b	50		50		mV/ns

- a. Rise and fall times are specified in terms of the edge rate measured in V/ns. This slew rate must be met across the minimum peak-to-peak portion of the clock waveform as shown.
- b. The minimum RST# slew rate applies only to the rising (de-assertion) edge of the reset signal and ensures that system noise cannot render a monotonic signal to appear bouncing in the switching range.

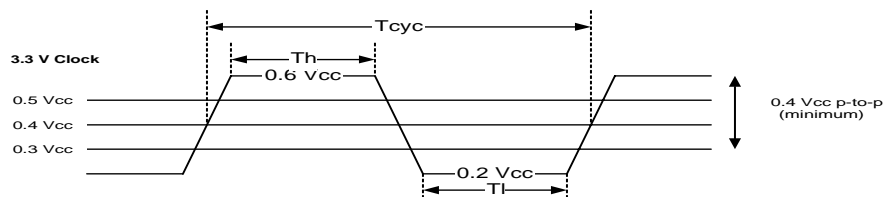

PCI Clock Timing.vsd

Figure 3. PCI Clock Timing

4.5.1.2 PCI/PCI-X Bus Interface Timing

Table 19. PCI Bus Interface Timing Parameters

Symbol	Parameter	PCI 66MHz		PCI 33 MHz		Units
		Min	Max	Min	Max	
TVAL	CLK to signal valid delay: bussed signals	2	6	2	11	ns
TVAL(ptp)	CLK to signal valid delay: point-to-point signals	2	6	2	12	ns
TON	Float to active delay	2		2		ns
TOFF	Active to float delay		14		28	ns
TSU	Input setup time to CLK: bussed signals	3		7		ns
TSU(ptp)	Input setup time to CLK: point-to-point signals	5		10, 12		ns
TH	Input hold time from CLK	0		0		ns

NOTES:

- Output timing measurements are as shown.
- REQ# and GNT# signals are point-to-point and have different output valid delay and input setup times than bussed signals. GNT# has a setup of 10 ns; REQ# has a setup of 12 ns. All other signals are bussed.
- Input timing measurements are as shown.

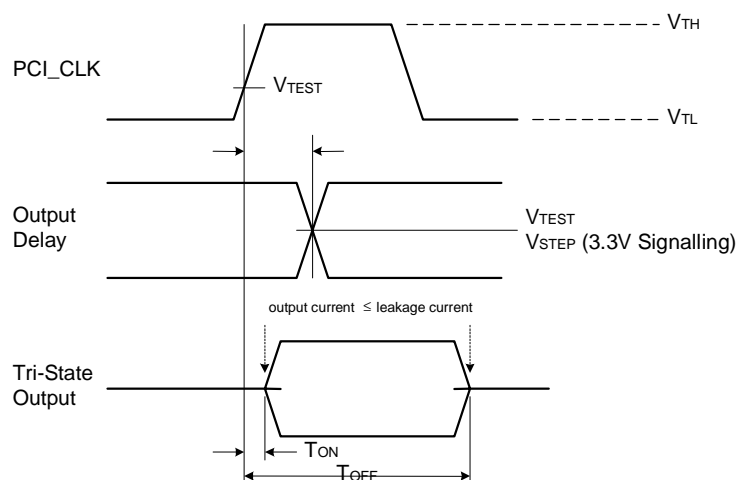

Figure 4. PCI Bus Interface Output Timing Measurement

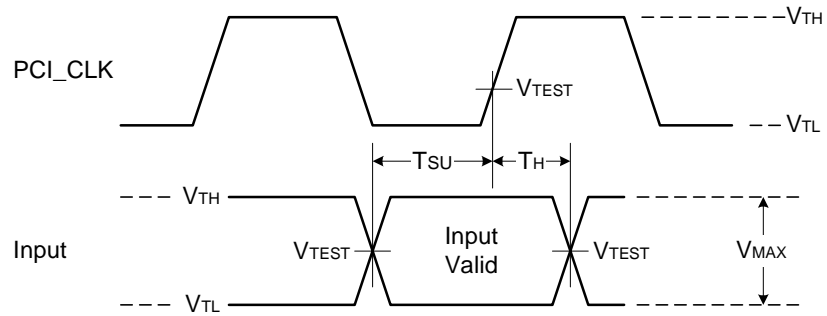

Figure 5. PCI Bus Interface Input Timing Measurement Conditions

Table 20. PCI Bus Interface Timing Measurement Conditions

Symbol	Parameter	PCI 66 MHz 3.3 v	Unit
V _{TH}	Input measurement test voltage (high)	0.6 * V _{CC}	V
V _{TL}	Input measurement test voltage (low)	0.2 * V _{CC}	V
V _{TEST}	Output measurement test voltage	0.4 * V _{CC}	V
	Input signal slew rate	1.5	V/ns

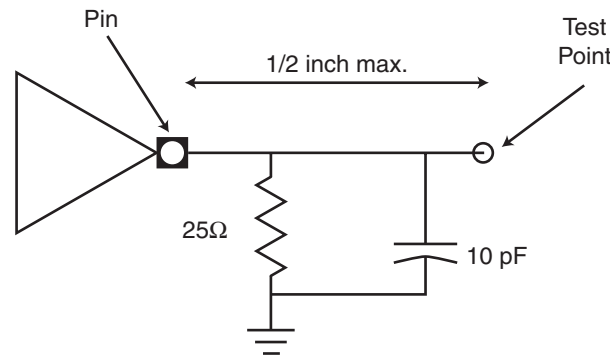

Figure 6. TVAL (max) Rising Edge Test Load

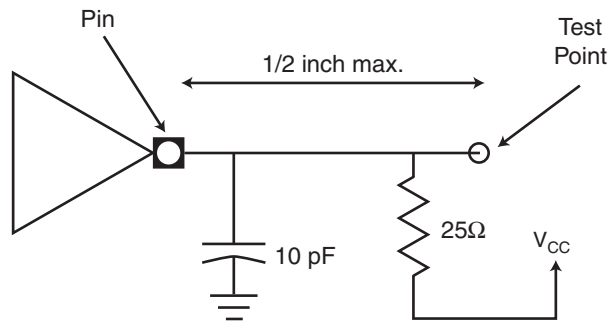

Figure 7. TVAL (max) Falling Edge Test Load

Figure 8. TVAL (min) Test Load

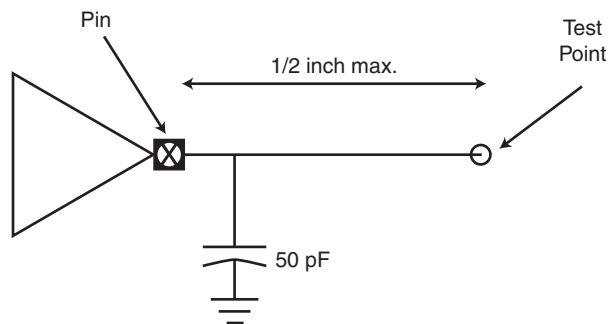

Figure 9. TVAL Test Load (PCI 5 V Signaling Environment)

NOTE: Note: 50 pF load used for maximum times. Minimum times are specified with 0 pF load.

4.5.2 Link Interface Timing

Table 21. Rise and Fall Times

Symbol	Parameter	Condition	Min	Max	Unit
TR	Clock rise time	0.8 V to 2.0 V	0.7		ns
TF	Clock fall time	2.0 V to 0.8 V	0.7		ns
TR	Data rise time	0.8 to 2.0 V	0.7		ns
TF	Data fall time	2.0 V to 0.8 V	0.7		ns

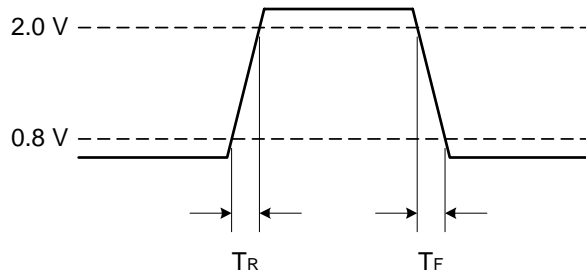

Figure 10. Link Interface Rise/Fall Timing

4.5.3 EEPROM Interface

Table 22. Link Interface Clock Requirements

Symbol	Parameter ^a	Min	Typ	Max	Unit
TPW	Microwire EESK pulse width		$T_{PERIOD} \times \frac{X}{64}$		ns
	SPI EESK pulse width		$T_{PERIOD} \times \frac{X}{32}$		ns

a. The EEPROM clock is derived from a 125 MHz internal clock.

Table 23. Link Interface Clock Requirements

Symbol	Parameter ^a	Min	Typ	Max	Unit
TDOS	EEDO setup time	TCYC*2			ns
TDOH	EEDO hold time	0			ns

a. The EE_DO setup and hold time is a function of the PCI bus clock cycle time but is referenced to O_EE_SK.

82541ER Gigabit Ethernet Controller



Note: This page is intentionally left blank.

5.0 Package and Pinout Information

This section describes the device physical characteristics. The pin number-to-signal mapping is indicated beginning with Table 25.

5.1 Package Information

The 82541ER device is a 196-lead plastic ball grid array (BGA) measuring 15 mm by 15 mm. The package dimensions are detailed below. The nominal ball pitch is 1 mm.

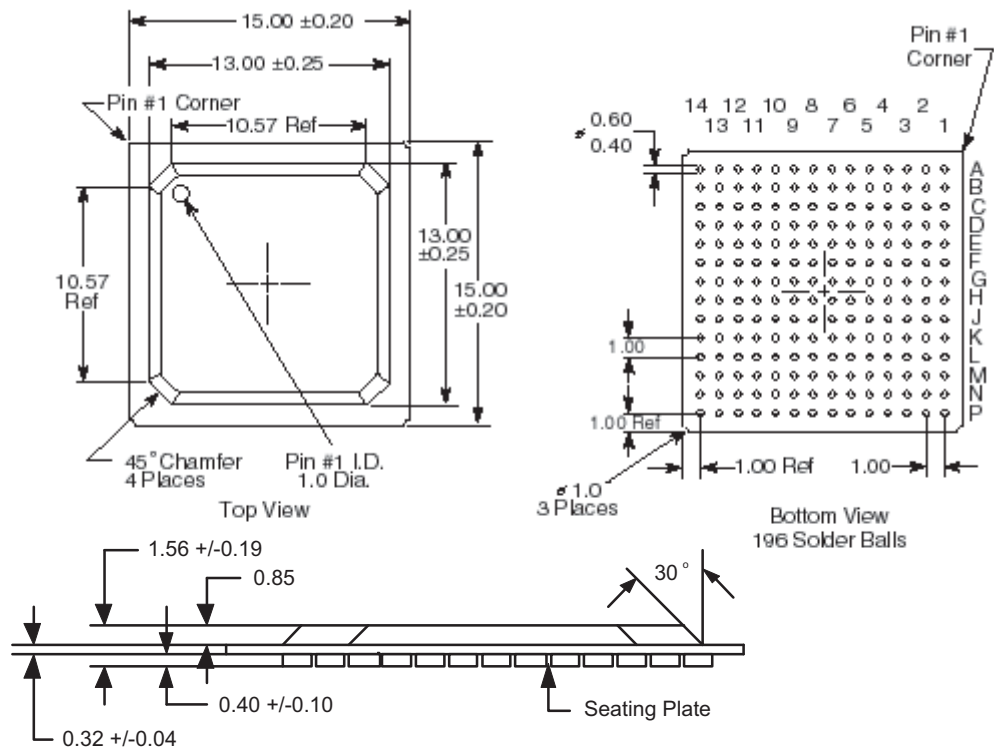

Figure 11. 82541ER Mechanical Specifications

Note: No changes to existing soldering processes are needed for the 0.32 mm substrate change.

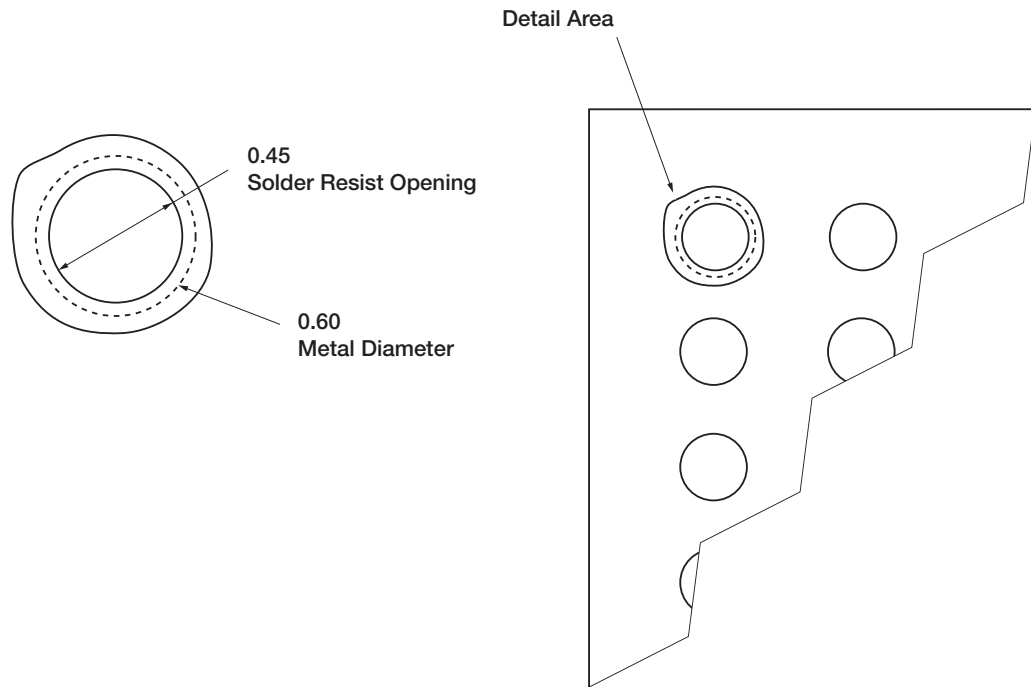

Figure 12. 196 PBGA Package Pad Detail

As illustrated in Figure 12, the Ethernet controller package uses solder mask defined pads. The copper area is 0.60 mm and the opening in the solder mask is 0.45mm. The nominal ball sphere diameter is 0.50 mm.

5.2 Thermal Specifications

The 82541ER device is specified for operation when the ambient temperature (T_A) is within the range of 0° C to 70° C.

T_C (case temperature) is calculated using the equation:

$$T_C = T_A + P (\theta_{JA} - \theta_{JC})$$

T_J (junction temperature) is calculated using the equation:

$$T_J = T_A + P \theta_{JA}$$

P (power consumption) is calculated by using the typical I_{CC} and nominal V_{CC} . The preliminary thermal resistances are shown in Table 24.

Table 24. Thermal Characteristics

Symbol	Parameter	Preliminary Value at specified airflow (m/s)			Units
		0	1	2	
θ_{JA}	Thermal resistance, junction-to-ambient	29	25.0	23.5	C/Watt
θ_{JC}	Thermal resistance, junction-to-case	11.1	11.1	11.1	C/Watt

Thermal resistances are determined empirically with test devices mounted on standard thermal test boards. Real system designs may have different characteristics due to board thickness, arrangement of ground planes, and proximity of other components. The case temperature measurements should be used to assure that the 82541ER device is operating under recommended conditions.

5.3 Pinout Information

Table 25. PCI Address, Data and Control Signals

Signal	Pin	Signal	Pin	Signal	Pin
AD[0]	N7	AD[16]	K1	C/BE#[0]	M4
AD[1]	M7	AD[17]	E3	C/BE#[1]	L3
AD[2]	P6	AD[18]	D1	C/BE#[2]	F3
AD[3]	P5	AD[19]	D2	C/BE#[3]	C4
AD[4]	N5	AD[20]	D3	PAR	J1
AD[5]	M5	AD[21]	C1	FRAME#	F2
AD[6]	P4	AD[22]	B1	IRDY#	F1
AD[7]	N4	AD[23]	B2	TRDY#	G3
AD[8]	P3	AD[24]	B4	STOP#	H1
AD[9]	N3	AD[25]	A5	DEVSEL#	H3
AD[10]	N2	AD[26]	B5	IDSEL	A4
AD[11]	M1	AD[27]	B6	VIO	G2
AD[12]	M2	AD[28]	C6		
AD[13]	M3	AD[29]	C7		
AD[14]	L1	AD[30]	A8		
AD[15]	L2	AD[31]	B8		

Table 26. PCI Arbitration Signals

Signal	Pin
REQ#	C3
GNT#	J3

Table 27. Interrupt Signals

Signal	Pin
INTA#	H2

Table 28. System Signals

Signal	Pin	Signal	Pin
CLK	G1	RST#	B9
M66EN	C2		

Table 29. Error Reporting Signals

Signal	Pin	Signal	Pin
SERR#	A2	PERR#	J2

Table 30. Power Management Signals

Signal	Pin
LAN_PWR_GOOD	A9
AUX_PWR	J12

Table 31. Serial EEPROM Interface Signals

Signal	Pin	Signal	Pin	Signal	Pin
EESK	M10	EEDI	P10	EECS	P7
EEDO	N10	EEMODE	J4		

Table 32. Serial FLASH Interface Signals

Signal	Pin	Signal	Pin	Signal	Pin
FLSH_SCK	N9	FLSH_SI	M11	FLSH_CE#	M9
FLSH_SO/LAN_DISABLE#	P9				

Table 33. LED Signals

Signal	Pin	Signal	Pin
LINK_UP#	A12	LINK100#	B11
ACTIVITY#	C11	LINK1000#	B12

Table 34. Other Signals

Signal	Pin	Signal	Pin
SDP[0]	N14	SDP[2]	N13
SDP[1]	P13	SDP[3]	M12

Table 35. IEEE Test Signals

Signal	Pin	Signal	Pin
IEEE_TEST-	D14	IEEE_TEST+	B14

Table 36. PHY Signals

Signal	Pin	Signal	Pin	Signal	Pin
MDI[0]-	C14	MDI[2]-	F14	XTAL1	K14
MDI[0]+	C13	MDI[2]+	F13	XTAL2	J14
MDI[1]-	E14	MDI[3]-	H14		
MDI[1]+	E13	MDI[3]+	H13		

Table 37. Test Interface Signals

Signal	Pin	Signal	Pin	Signal	Pin
JTAG_TCK	L14	JTAG_TDO	M14	JTAG_TRST#	L13
JTAG_TDI	M13	JTAG_TMS	L12	TEST	A13

Table 38. Digital Power Signals

Signal	Pin	Signal	Pin	Signal	Pin
3.3V	A3	1.2V	G5	1.2V	J9
3.3V	A7	1.2V	G6	1.2V	K10
3.3V	A11	1.2V	H5	1.2V	K11
3.3V	E1	1.2V	H6	1.2V	K5
3.3V	K3	1.2V	H7	1.2V	K6
3.3V	K4	1.2V	H8	1.2V	K7
3.3V	K13	1.2V	J10	1.2V	K8
3.3V	N6	1.2V	J11	1.2V	K9
3.3V	N8	1.2V	J5	1.2V	L10
3.3V	P2	1.2V	J6	1.2V	L4
3.3V	P12	1.2V	J7	1.2V	L5
		1.2V	J8	1.2V	L9

Table 39. Analog Power Signals

Signal	Pin	Signal	Pin	Signal	Pin
ANALOG_1.2V	E11	ANALOG_1.8V	D11	CLKR_1.8V	D12
ANALOG_1.2V	E12	ANALOG_1.8V	G12	XTAL_1.8V	J13
ANALOG_1.2V	G13	PLL_1.2V	G4		
ANALOG_1.2V	H11	PLL_1.2V	H4		

Table 40. Grounds and No Connect Signals

Signal	Pin	Signal	Pin	Signal	Pin	Signal	Pin
VSS	B3	VSS	F5	VSS	M6	NC	L8
VSS	B7	VSS	F6	VSS	N1	NC	P1
VSS	C10	VSS	F7	VSS	N12	NC	P14
VSS	D5	VSS	F8	VSS	P8	Pull up to VCC ^a	A10
VSS	D6	VSS	F9	AVSS	C12	Pull up to VCC ^a	B10
VSS	D7	VSS	F10	AVSS	D13	Pull up to VCC ^a	C9
VSS	D8	VSS	G7	AVSS	F11	VSS	D4
VSS	E10	VSS	G8	AVSS	G11	VSS	E4
VSS	E2	VSS	G9	AVSS	G14	NC	A6
VSS	E5	VSS	G10	AVSS	K12	NC	C5
VSS	E6	VSS	H9	NC	A1	NC	F12
VSS	E7	VSS	H10	NC	A14	NC	L7
VSS	E8	VSS	K2	NC	D9	NC	M8
VSS	E9	VSS	L6	NC	D10	NC	N11
VSS	F4	VSS	L11	NC	H12	NC	C8

a. Use a 1 K Ω resistor.

Table 41. Voltage Regulation Control Signals

Signal	Pin	Signal	Pin
CTRL18	B13	CTRL12	P11

Table 42. Signal Names in Pin Order (Sheet 1 of 6)

Signal Name	Pin
NC	A1
SERR#	A2
3.3V	A3
IDSEL	A4
AD[25]	A5
NC	A6
3.3V	A7
AD[30]	A8
LAN_PWR_GOOD	A9
Pull up to VCC ^a	A10
3.3V	A11
LINK_LED#	A12
TEST	A13
NC	A14
AD[22]	B1
AD[23]	B2
VSS	B3
AD[24]	B4
AD[26]	B5
AD[27]	B6
VSS	B7
AD[31]	B8
RST#	B9
Pull up to VCC ^a	B10
LINK100#	B11
LINK1000#	B12
CTRL18	B13
IEEE_TEST+	B14
AD[21]	C1
M66EN	C2
REQ#	C3
C/BE#[3]	C4
NC	C5

Table 42. Signal Names in Pin Order (Sheet 2 of 6) (Continued)

AD[28]	C6
AD[29]	C7
NC	C8
Pull up to VCC ^a	C9
VSS	C10
ACTIVITY#	C11
AVSS	C12
MDI[0]+	C13
MDI[0]-	C14
AD[18]	D1
AD[19]	D2
AD[20]	D3
VSS	D4
VSS	D5
VSS	D6
VSS	D7
VSS	D8
NC	D9
NC	D10
ANALOG_1.8V	D11
CLKR_1.8V	D12
AVSS	D13
IEEE_TEST-	D14
3.3V	E1
VSS	E2
AD[17]	E3
VSS	E4
VSS	E5
VSS	E6
VSS	E7
VSS	E8
VSS	E9
VSS	E10
ANALOG_1.2V	E11
ANALOG_1.2V	E12
MDI[1]+	E13

Table 42. Signal Names in Pin Order (Sheet 3 of 6) (Continued)

MDI[1]-	E14
IRDY#	F1
FRAME#	F2
C/BE#[2]	F3
VSS	F4
VSS	F5
VSS	F6
VSS	F7
VSS	F8
VSS	F9
VSS	F10
AVSS	F11
NC	F12
MDI[2]+	F13
MDI[2]-	F14
CLK	G1
VIO	G2
TRDY#	G3
PLL_1.2V	G4
1.2V	G5
1.2V	G6
VSS	G7
VSS	G8
VSS	G9
VSS	G10
AVSS	G11
ANALOG_1.8V	G12
ANALOG_1.2V	G13
AVSS	G14
STOP#	H1
INTA#	H2
DEVSEL#	H3
PLL_1.2V	H4
1.2V	H5
1.2V	H6
1.2V	H7

Table 42. Signal Names in Pin Order (Sheet 4 of 6) (Continued)

1.2V	H8
VSS	H9
VSS	H10
ANALOG_1.2V	H11
NC	H12
MDI[3]+	H13
MDI[3]-	H14
PAR	J1
PERR#	J2
GNT#	J3
EEMODE	J4
1.2V	J5
1.2V	J6
1.2V	J7
1.2V	J8
1.2V	J9
1.2V	J10
1.2V	J11
AUX_PWR	J12
XTAL_1.8V	J13
XTAL2	J14
AD[16]	K1
VSS	K2
3.3V	K3
3.3V	K4
1.2V	K5
1.2V	K6
1.2V	K7
1.2V	K8
1.2V	K9
1.2V	K10
1.2V	K11
AVSS	K12
3.3V	K13
XTAL1	K14
AD[14]	L1

Table 42. Signal Names in Pin Order (Sheet 5 of 6) (Continued)

AD[15]	L2
C/BE#[1]	L3
1.2V	L4
1.2V	L5
VSS	L6
NC	L7
NC	L8
1.2V	L9
1.2V	L10
VSS	L11
JTAG_TMS	L12
JTAG_TRST#	L13
JTAG_TCK	L14
AD[11]	M1
AD[12]	M2
AD[13]	M3
C/BE#[0]#	M4
AD[5]	M5
VSS	M6
AD[1]	M7
NC	M8
FLSH_CE#	M9
EESK	M10
FLSH_SI	M11
SDP[3]	M12
JTAG_TDI	M13
JTAG_TDO	M14
VSS	N1
AD[10]	N2
AD[9]	N3
AD[7]	N4
AD[4]	N5
3.3V	N6
AD[0]	N7
3.3V	N8
FLSH_SCK	N9

Table 42. Signal Names in Pin Order (Sheet 6 of 6) (Continued)

EEDO	N10
NC	N11
VSS	N12
SDP[2]	N13
SDP[0]	N14
NC	P1
3.3V	P2
AD[8]	P3
AD[6]	P4
AD[3]	P5
AD[2]	P6
EECS	P7
VSS	P8
FLSH_SO	P9
EEDI	P10
CTRL12	P11
3.3V	P12
SDP[1]	P13
NC	P14

a. Use a 1 K Ω resistor.

5.4 Visual Pin Assignments

	A	B	C	D	E	F	G	H	J	K	L	M	N	P
1	NC	AD[22]	AD[21]	AD[18]	3.3V	IRDY#	CLK	STOP#	PAR	AD[16]	AD[14]	AD[11]	VSS	NC
2	SERR#	AD[23]	M66EN	AD[19]	VSS	FRAME#	VIO	INTA#	PERR#	VSS	AD[15]	AD[12]	AD[10]	3.3V
3	3.3V	VSS	REQ#	AD[20]	AD[17]	C/BE#[2]	TRDY#	DVSEL#	GNT#	3.3V	C/B3#[1]	AD[13]	AD[9]	AD[8]
4	IDSEL	AD[24]	C/BE#[3]	VSS	VSS	VSS	PLL_1.2V	PLL_1.2V	EEMODE	3.3V	1.2V	C/BE#[0]	AD[7]	AD[6]
5	AD[25]	AD[26]	NC	VSS	VSS	VSS	1.2V	1.2V	1.2V	1.2V	1.2V	AD[5]	AD[4]	AD[3]
6	NC	AD[27]	AD[28]	VSS	VSS	VSS	1.2V	1.2V	1.2V	1.2V	VSS	VSS	3.3V	AD[2]
7	3.3V	VSS	AD[29]	VSS	VSS	VSS	VSS	1.2V	1.2V	1.2V	NC	AD[1]	AD[0]	EECS
8	AD[30]	AD[31]	NC	VSS	VSS	VSS	VSS	1.2V	1.2V	1.2V	NC	NC	3.3V	VSS
9	LAN_PWR_GOOD	RST#	Pull Up To VCC	NC	VSS	VSS	VSS	VSS	1.2V	1.2V	1.2V	FLSH_CE#	FLSH_SCK	FLSH_SO
10	Pull Up To VCC	Pull Up To VCC	VSS	NC	VSS	VSS	VSS	VSS	1.2V	1.2V	1.2V	EESK	EEDO	EEDI
11	3.3V	LINK100#	ACTIVITY#	ANALOG_1.8V	ANALOG_1.2V	AVSS	AVSS	ANALOG_1.2V	1.2V	1.2V	VSS	FLSH_SI	NC	CTRL12
12	LINK_LED#	LINK1000#	AVSS	CLKR_1.8V	ANALOG_1.2V	NC	ANALOG_1.8V	NC	AUX_PWR	AVSS	JTAG_TMS	SDP[3]	VSS	3.3V
13	TEST	CTRL18	MDI[0]+	AVSS	MDI[1]+	MDI[2]+	ANALOG_1.2V	MDI[3]+	XTAL_1.8V	3.3V	JTAG_TRST#	JTAG_TDI	SDP[2]	SDP[1]
14	NC	IEEE_TEST+	MDI[0]-	IEEE_TEST-	MDI[1]-	MDI[2]-	AVSS	MDI[3]-	XTAL2	XTAL1	JTAG_TCK	JTAG_TDO	SDP[0]	NC

Pins A10, B-10, and C9 - Use 1K ohm resistors.

Figure 13. Visual Pin Assignments