

FEATURES

- Operates as a GTL-/GTL/GTL+ to LVTTTL or LVTTTL to GTL-/GTL/GTL+ Translator
- Series Termination on TTL Output of 30 Ω
- Latch-Up Testing Done to JEDEC Standard JESD 78
- ESD Performance Tested Per JESD 22
 - 2000-V Human-Body Model (A114-B, Class II)
 - 200-V Machine Model (A115-A)
 - 1000-V Charged-Device Model (C101)

PW PACKAGE
(TOP VIEW)

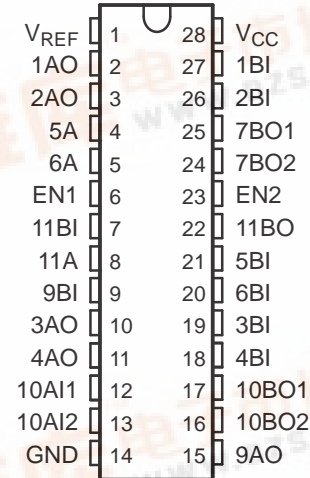

DESCRIPTION/ORDERING INFORMATION

The SN74GTL2107 is a 12-bit translator that interfaces between the 3.3-V LVTTTL chip set I/O and the Xeon™ processor GTL-/GTL/GTL+ I/O. The device is designed for platform health management in dual-processor applications.

PIN DESCRIPTION

PIN NO.	SYMBOL	NAME AND FUNCTION
1	V_{REF}	GTL reference voltage
2–6, 8, 10–13, 15, 23	EN_n nA_n	Data and enable inputs/outputs (LVTTTL) on all inputs and pin 15 output. Remaining outputs are open drain.
7, 9, 16, 17–22, 24–27	nB_n	Data inputs/outputs (GTL-/GTL/GTL+)
14	GND	Ground (0 V)
28	V_{CC}	Positive supply voltage

ORDERING INFORMATION

T_A	PACKAGE ⁽¹⁾	ORDERABLE PART NUMBER	TOP-SIDE MARKING
–40°C to 85°C	TSSOP – PW	Tube	SN74GTL2107PW
		Tape and reel	SN74GTL2107PWR
			GK2107

(1) Package drawings, standard packing quantities, thermal data, symbolization, and PCB design guidelines are available at www.ti.com/sc/package.



Please be aware that an important notice concerning availability, standard warranty, and use in critical applications of Texas Instruments semiconductor products and disclaimers thereto appears at the end of this data sheet.

SN74GTL2107

12-BIT GTL-/GTL/GTL+ TO LVTTTL TRANSLATOR

SCLS699–JULY 2006

FUNCTION TABLES⁽¹⁾

INPUTS		OUTPUT 1AO/2AO (OPEN DRAIN)
EN1	1BI/2BI	
H	L	L
H	H	H
L	X	H

(1) H = High voltage level, L = Low voltage level

INPUTS		OUTPUT 3AO/4AO (OPEN DRAIN)
EN2	3BI/4BI	
H	L	L
H	H	H
L	X	H

INPUT 9BI	OUTPUT 9AO
L	L
H	H

INPUTS		OUTPUT 10BO1/10BO2
10AI1/10AI2	9BI	
L	L	L
L	H	L
H	L	L
H	H	H

INPUTS		INPUT/OUTPUT 5A/6A (OPEN DRAIN)	OUTPUT 7BO1/7BO2
EN2	5BI/6BI		
H	L	L	H ⁽¹⁾
H	H	L ⁽²⁾	L
H	H	H	H
L	H	L ⁽²⁾	L
L	H	H	H
L	L	H	H
L	L	L ⁽²⁾	H

- (1) The enable on 7BO1/7BO2 includes a delay that prevents a transient condition (where 5BI/6BI goes from low to high, and the low to high on 5A/6A lags up to 100 ns) from causing a low glitch on the 7BO1/7BO2 outputs.
- (2) Open-drain input/output terminal is driven to a logic-low state by an external driver.

INPUT 11BI	INPUT/OUTPUT 11A (OPEN DRAIN)	OUTPUT 11BO
L	H	L
L	L ⁽¹⁾	H
H	L	H

- (1) Open-drain input/output terminal is driven to a logic-low state by an external driver.

LOGIC SYMBOL

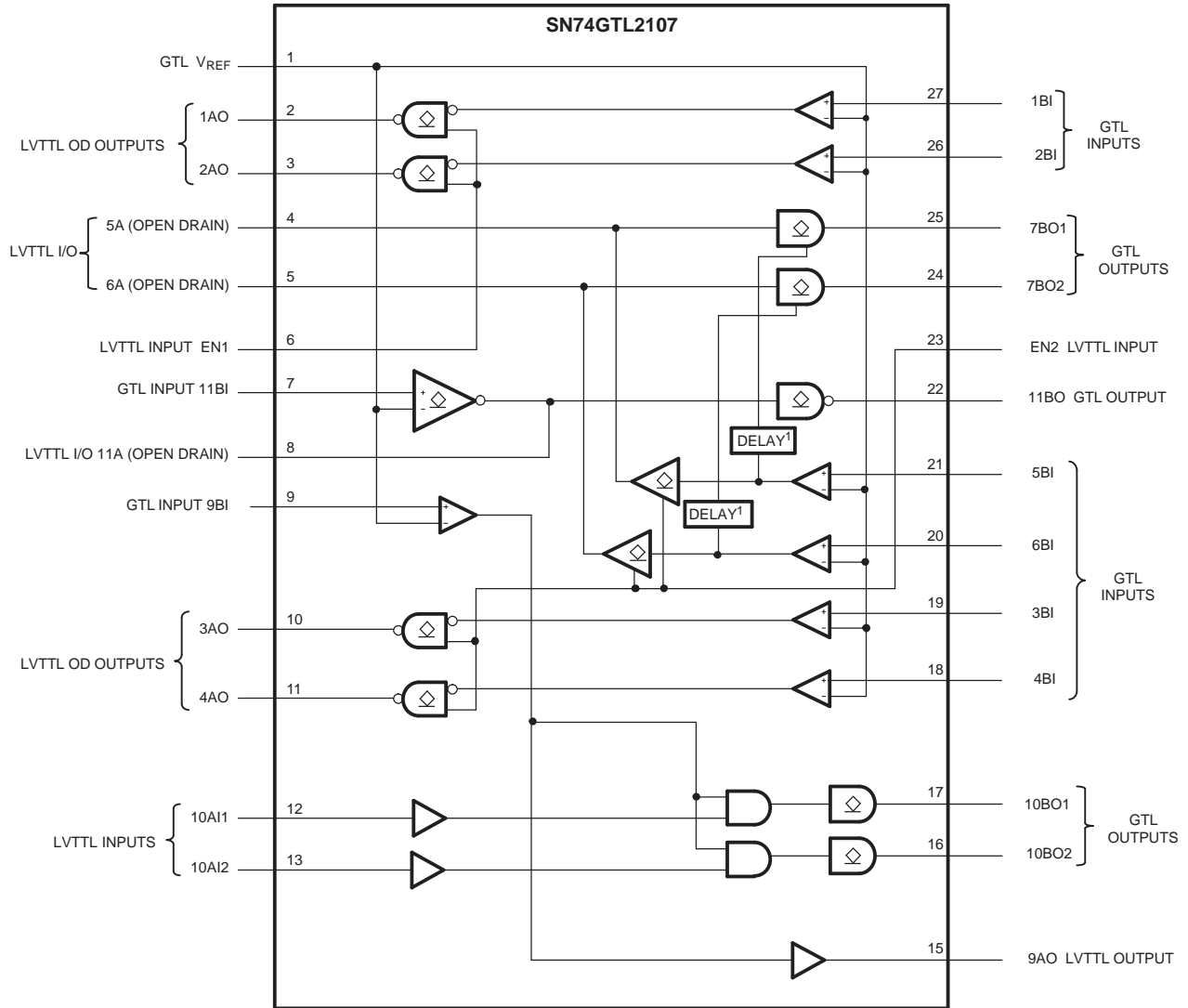

(1) The enable on 7BO1/7BO2 includes a delay that prevents a transient condition (where 5BI/6BI go from low to high, and the low to high on 5A/6A lags up to 100 ns) from causing a low glitch on the 7BO1/7BO2 outputs.

SN74GTL2107

12-BIT GTL-/GTL/GTL+ TO LVTTTL TRANSLATOR

SCLS699–JULY 2006



Absolute Maximum Ratings⁽¹⁾⁽²⁾

over operating free-air temperature range (unless otherwise noted)

		MIN	MAX	UNIT	
V _{CC}	Supply voltage range	−0.5	4.6	V	
V _I	Input voltage range ⁽³⁾	A port (LVTTTL)	−0.5	4.6	V
		B port (GTL)	−0.5	4.6	
V _O	Output voltage range (output in OFF or HIGH state) ⁽³⁾	A port	−0.5	4.6	V
		B port	−0.5	4.6	
I _{IK}	Input diode current	V _I < 0	−50	mA	
I _{OK}	Output diode current	V _O < 0	−50	mA	
	Current into any output in the LOW state	A port	32	mA	
		B port	30		
	Current into any output in the HIGH state	A port	−32	mA	
θ _{JA}	Package thermal impedance ⁽⁴⁾		62	°C/W	
T _{stg}	Storage temperature range	−60	150	°C	

- (1) Stresses beyond those listed under "absolute maximum ratings" may cause permanent damage to the device. These are stress ratings only, and functional operation of the device at these or any other conditions beyond those indicated under "recommended operating conditions" is not implied. Exposure to absolute-maximum-rated conditions for extended periods may affect device reliability.
- (2) Voltages are referenced to GND (ground = 0 V).
- (3) The input and output negative voltage ratings may be exceeded if the input and output clamp current ratings are observed.
- (4) The performance capability of a high-performance integrated circuit, in conjunction with its thermal environment, can create junction temperatures that are detrimental to reliability. The maximum junction temperature of this integrated circuit should not exceed 150°C.

Recommended Operating Conditions

		MIN	NOM	MAX	UNIT	
V _{CC}	Supply voltage	3	3.3	3.6	V	
V _{TT}	Termination voltage	GTL−	0.85	0.9	0.95	V
		GTL	1.14	1.2	1.26	
		GTL+	1.35	1.5	1.65	
V _{REF}	Reference voltage	Overall	0.5	2/3 V _{TT}	1.8	V
		GTL−	0.5	0.6	0.63	
		GTL	0.76	0.8	0.84	
		GTL+	0.87	1	1.1	
V _I	Input voltage	A port	0	3.3	3.6	V
		B port	0	V _{TT}	3.6	
V _{IH}	High-level input voltage	A port	2			V
		B port	V _{REF} + 50 mV			
V _{IL}	Low-level input voltage	A port		0.8		V
		B port		V _{REF} − 50 mV		
I _{OH}	High-level output current	A port		−16	mA	
I _{OL}	Low-level output current	A port		16	mA	
		B port		15		
T _A	Operating free-air temperature	−40		85	°C	

Electrical Characteristics

over recommended operating conditions

PARAMETER		TEST CONDITIONS	–40°C to 85°C			UNIT
			MIN	TYP ⁽¹⁾	MAX	
V _{OH} ⁽²⁾	A port	V _{CC} = 3 V to 3.6 V, I _{OH} = –100 μA	V _{CC} – 0.2			V
		V _{CC} = 3 V, I _{OH} = –16 mA	2.1			
V _{OL} ⁽²⁾	A port	V _{CC} = 3 V, I _{OL} = 16 mA	0.8			V
	B port	V _{CC} = 3 V, I _{OL} = 15 mA	0.4			
I _I	A port	V _{CC} = 3.6 V, V _I = V _{CC}	±1			μA
		V _{CC} = 3.6 V, V _I = 0 V	±1			
	B port	V _{CC} = 3.6 V, V _I = V _{TT} or GND	±1			
I _{CC}	A or B port	V _{CC} = 3.6 V, V _I = V _{CC} or GND, I _O = 0	12			mA
ΔI _{CC} ⁽³⁾	A port or control inputs	V _{CC} = 3.6 V, V _I = V _{CC} – 0.6 V	500			μA
C _{IO}	A port	V _O = 3 V or 0	5			pF
	B port	V _O = V _{TT} or 0	4			

(1) All typical values are at V_{CC} = 3.3 V, T_A = 25°C.

(2) The input and output voltage ratings may be exceeded if the input and output current ratings are observed.

(3) This is the increase in supply current for each input that is at the specified LVTTTL voltage, rather than V_{CC} or GND.

Switching Characteristics

over recommended operating free-air temperature range

PARAMETER		WAVEFORM	GTL–			GTL			GTL+			UNIT
			V _{CC} = 3.3 V ± 0.3 V V _{REF} = 0.6 V			V _{CC} = 3.3 V ± 0.3 V V _{REF} = 0.8 V			V _{CC} = 3.3 V ± 0.3 V V _{REF} = 1 V			
			MIN	TYP ⁽¹⁾	MAX	MIN	TYP ⁽¹⁾	MAX	MIN	TYP ⁽¹⁾	MAX	
t _{PLH}	An to Bn	1	2	4	8	2	4	8	2	4	8	ns
t _{PHL}			2	5.5	10	2	5.5	10	2	5.5	10	
t _{PLH}	9BI to 9AO	2	2	5.5	10	2	5.5	10	2	5.5	10	ns
t _{PHL}			2	5.5	10	2	5.5	10	2	5.5	10	
t _{PLH}	9BI to 10BOn	3	2	6	11	2	6	11	2	6	11	ns
t _{PHL}			2	6	11	2	6	11	2	6	11	
t _{PLH}	11BI to 11BO	3	2	8	13	2	8	13	2	8	13	ns
t _{PHL} ⁽²⁾			2	14	21	2	14	21	2	14	21	
t _{PLH}	Bn to Bn	3	4	7	11	4	7	11	4	7	11	ns
t _{PHL}			120	205	350	120	205	350	120	205	350	
t _{PLZ}	ENn to An	5	1	3	7	1	3	7	1	3	7	ns
t _{PZL}			1	3	7	1	3	7	1	3	7	
t _{PLZ}	Bn to An (I/O)	4	2	5	10	2	5	10	2	5	10	ns
t _{PZL}			2	5	10	2	5	10	2	5	10	
t _{PLZ}	Bn to An	4	2	5	10	2	5	10	2	5	10	ns
t _{PZL}			2	5	10	2	5	10	2	5	10	
t _{PLZ}	EN2 to An (I/O)	5	1	3	7	1	3	7	1	3	7	ns
t _{PZL}			1	3	7	1	3	7	1	3	7	

(1) All typical values are measured at V_{CC} = 3.3 V and T_A = 25°C.

(2) Includes –7.6-ns RC rise time of test-load pullup on 11 A, 1.5-kΩ pullup, and 21-pF load on 11 A has approximately 23-ns RC rise time.

SN74GTL2107 12-BIT GTL-/GTL/GTL+ TO LVTTL TRANSLATOR

SCLS699—JULY 2006

PARAMETER MEASUREMENT INFORMATION

$V_{TT} = 1.2\text{ V}$, $V_{REF} = 0.8\text{ V}$ for GTL and $V_{TT} = 1.5\text{ V}$, $V_{REF} = 1\text{ V}$ for GTL+

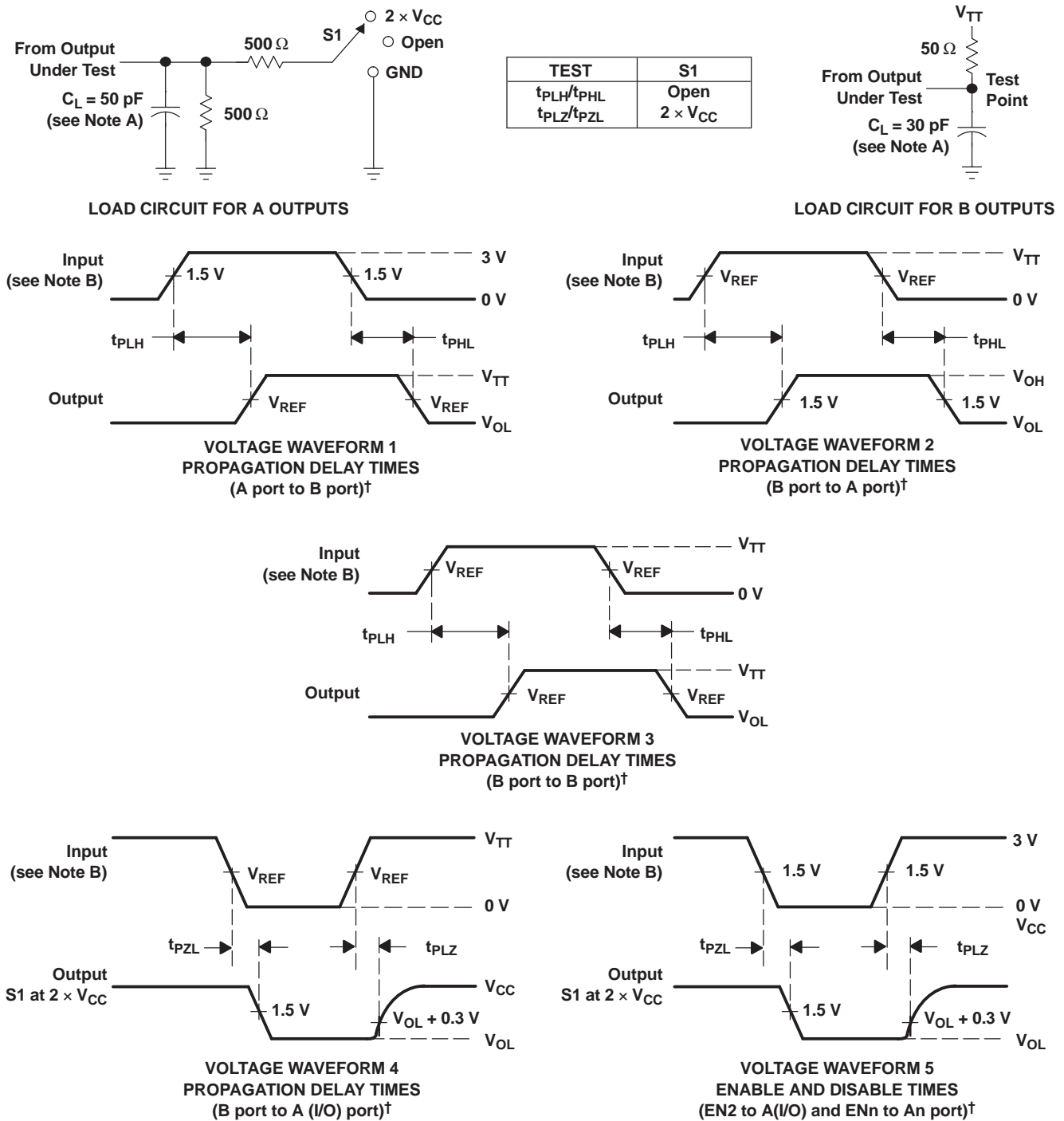

[†] All control inputs are LVTTL levels.

NOTES: A. C_L includes probe and jig capacitance.

B. All input pulses are supplied by generators having the following characteristics: $PRR \leq 10\text{ MHz}$, $Z_O = 50\ \Omega$, $t_r \leq 2.5\text{ ns}$, $t_f \leq 2.5\text{ ns}$.

C. The outputs are measured one at a time, with one transition per measurement.

Figure 1. Load Circuits and Voltage Waveforms

APPLICATION INFORMATION

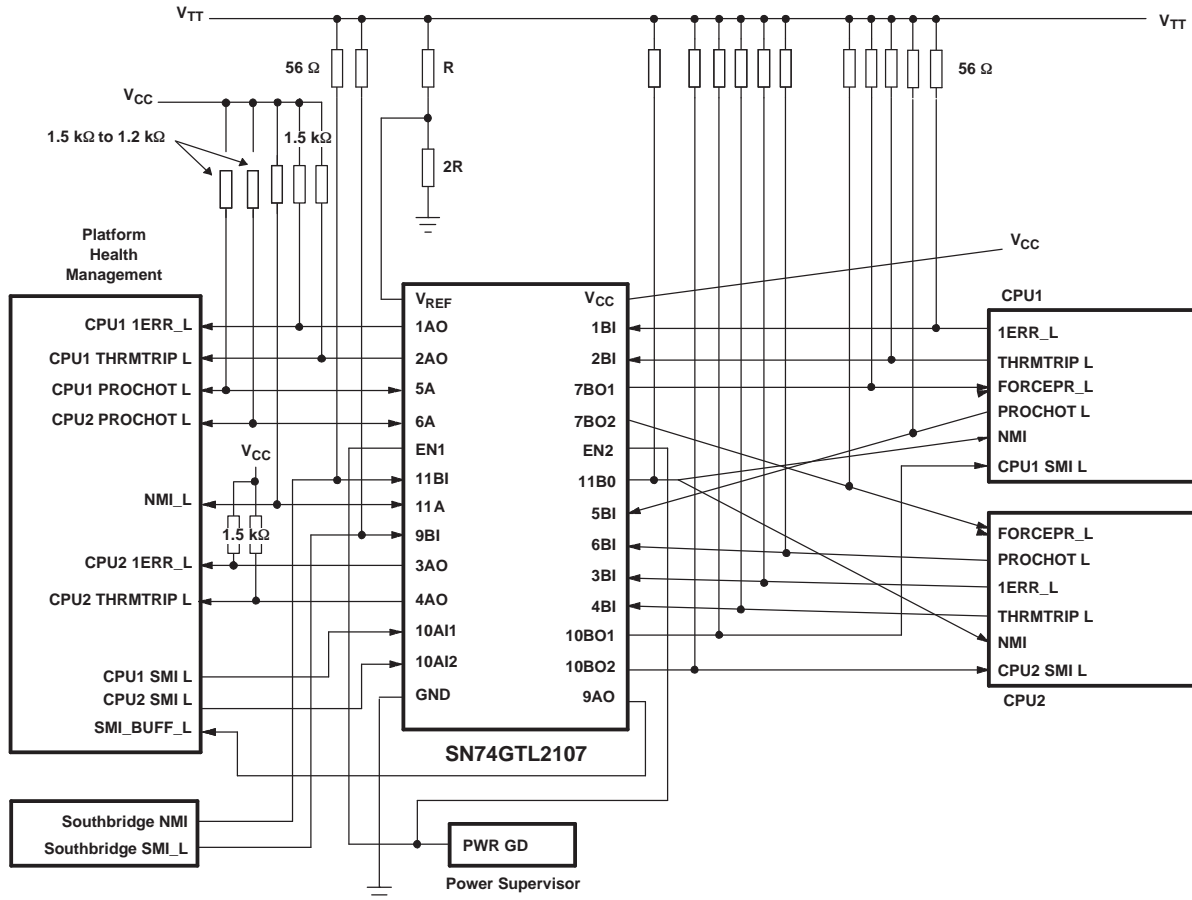

Frequently Asked Questions

Question 1: On the SN74GTL2107 LVTTL input, specifically 10AI1 and 10AI2, when the SN74GTL2107 is powered down, these inputs may be pulled up to 3.3 V, and we want to ensure that there is no leakage path to the power rail under this condition. Are the LVTTL inputs high impedance when the device is powered down, and will there be any leakage?

Answer 1: When the device is powered down, the LVTTL inputs are in a high-impedance state and do not leak to V_{DD} if they are pulled high while the device is powered down.

Question 2: Do all the LVTTL inputs have the same powered-down characteristic?

Answer 2: Yes

Question 3: What is the condition of the other GTL I/O and LVTTL output pins when the device is powered down?

Answer 3: The open-drain outputs, both GTL and LVTTL, do not leak to the power supply if they are pulled high while the device is powered down. The GTL inputs also do not leak to the power supply under the same conditions. The LVTTL totem-pole outputs, however, are not open-drain type outputs, and there is current flow on these pins if they are pulled high when V_{DD} is at ground.

PACKAGING INFORMATION

Orderable Device	Status ⁽¹⁾	Package Type	Package Drawing	Pins	Package Qty	Eco Plan ⁽²⁾	Lead/Ball Finish	MSL Peak Temp ⁽³⁾
SN74GTL2107PW	ACTIVE	TSSOP	PW	28	50	Green (RoHS & no Sb/Br)	CU NIPDAU	Level-1-260C-UNLIM
SN74GTL2107PWG4	ACTIVE	TSSOP	PW	28	50	Green (RoHS & no Sb/Br)	CU NIPDAU	Level-1-260C-UNLIM
SN74GTL2107PWR	ACTIVE	TSSOP	PW	28	2000	Green (RoHS & no Sb/Br)	CU NIPDAU	Level-1-260C-UNLIM
SN74GTL2107PWRG4	ACTIVE	TSSOP	PW	28	2000	Green (RoHS & no Sb/Br)	CU NIPDAU	Level-1-260C-UNLIM

⁽¹⁾ The marketing status values are defined as follows:

ACTIVE: Product device recommended for new designs.

LIFEBUY: TI has announced that the device will be discontinued, and a lifetime-buy period is in effect.

NRND: Not recommended for new designs. Device is in production to support existing customers, but TI does not recommend using this part in a new design.

PREVIEW: Device has been announced but is not in production. Samples may or may not be available.

OBSOLETE: TI has discontinued the production of the device.

⁽²⁾ Eco Plan - The planned eco-friendly classification: Pb-Free (RoHS), Pb-Free (RoHS Exempt), or Green (RoHS & no Sb/Br) - please check <http://www.ti.com/productcontent> for the latest availability information and additional product content details.

TBD: The Pb-Free/Green conversion plan has not been defined.

Pb-Free (RoHS): TI's terms "Lead-Free" or "Pb-Free" mean semiconductor products that are compatible with the current RoHS requirements for all 6 substances, including the requirement that lead not exceed 0.1% by weight in homogeneous materials. Where designed to be soldered at high temperatures, TI Pb-Free products are suitable for use in specified lead-free processes.

Pb-Free (RoHS Exempt): This component has a RoHS exemption for either 1) lead-based flip-chip solder bumps used between the die and package, or 2) lead-based die adhesive used between the die and leadframe. The component is otherwise considered Pb-Free (RoHS compatible) as defined above.

Green (RoHS & no Sb/Br): TI defines "Green" to mean Pb-Free (RoHS compatible), and free of Bromine (Br) and Antimony (Sb) based flame retardants (Br or Sb do not exceed 0.1% by weight in homogeneous material)

⁽³⁾ MSL, Peak Temp. -- The Moisture Sensitivity Level rating according to the JEDEC industry standard classifications, and peak solder temperature.

Important Information and Disclaimer:The information provided on this page represents TI's knowledge and belief as of the date that it is provided. TI bases its knowledge and belief on information provided by third parties, and makes no representation or warranty as to the accuracy of such information. Efforts are underway to better integrate information from third parties. TI has taken and continues to take reasonable steps to provide representative and accurate information but may not have conducted destructive testing or chemical analysis on incoming materials and chemicals. TI and TI suppliers consider certain information to be proprietary, and thus CAS numbers and other limited information may not be available for release.

In no event shall TI's liability arising out of such information exceed the total purchase price of the TI part(s) at issue in this document sold by TI to Customer on an annual basis.

MECHANICAL DATA

MTSS001C – JANUARY 1995 – REVISED FEBRUARY 1999

PW (R-PDSO-G)**

PLASTIC SMALL-OUTLINE PACKAGE

14 PINS SHOWN

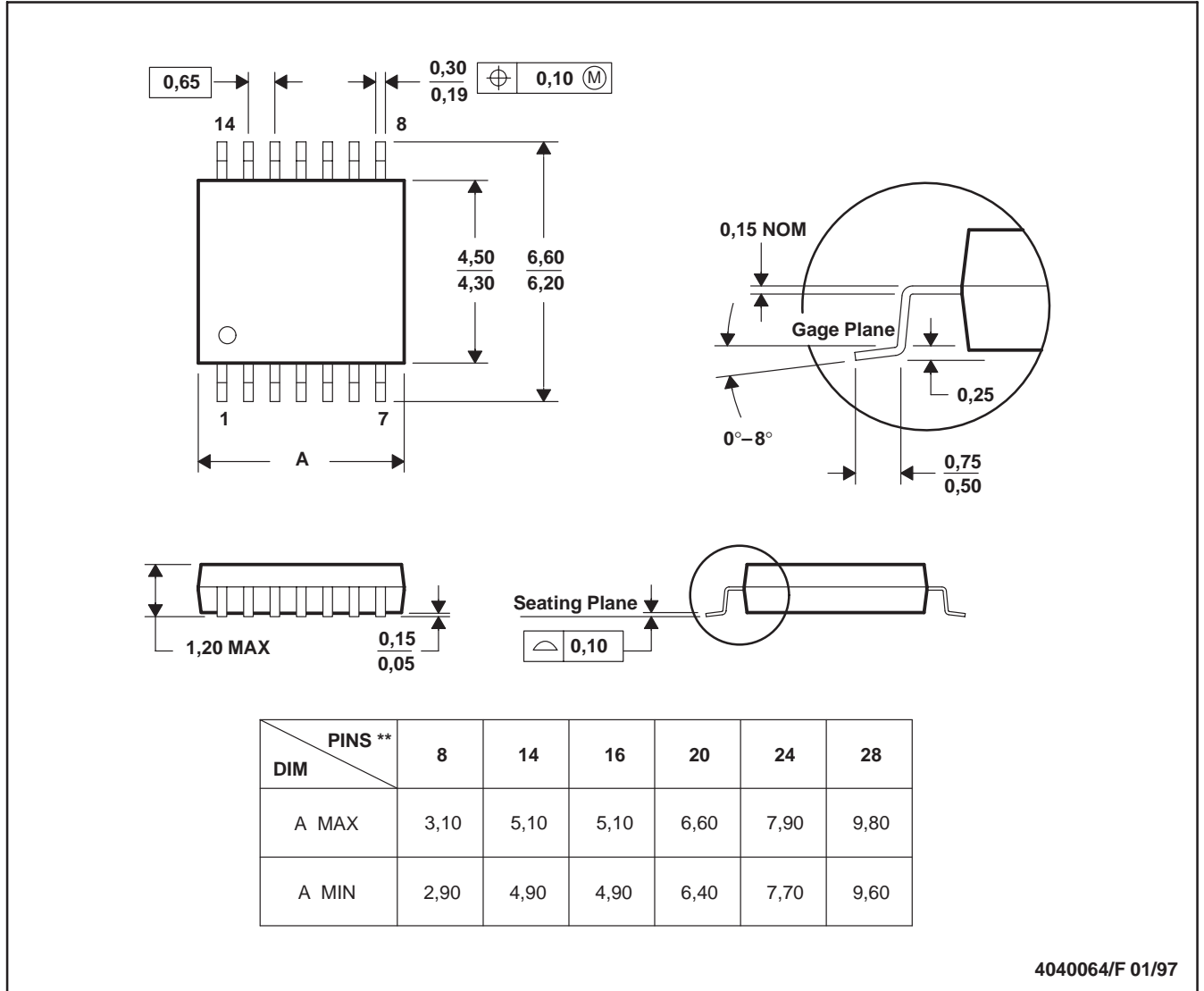

4040064/F 01/97

- NOTES: A. All linear dimensions are in millimeters.
 B. This drawing is subject to change without notice.
 C. Body dimensions do not include mold flash or protrusion not to exceed 0,15.
 D. Falls within JEDEC MO-153

IMPORTANT NOTICE

Texas Instruments Incorporated and its subsidiaries (TI) reserve the right to make corrections, modifications, enhancements, improvements, and other changes to its products and services at any time and to discontinue any product or service without notice. Customers should obtain the latest relevant information before placing orders and should verify that such information is current and complete. All products are sold subject to TI's terms and conditions of sale supplied at the time of order acknowledgment.

TI warrants performance of its hardware products to the specifications applicable at the time of sale in accordance with TI's standard warranty. Testing and other quality control techniques are used to the extent TI deems necessary to support this warranty. Except where mandated by government requirements, testing of all parameters of each product is not necessarily performed.

TI assumes no liability for applications assistance or customer product design. Customers are responsible for their products and applications using TI components. To minimize the risks associated with customer products and applications, customers should provide adequate design and operating safeguards.

TI does not warrant or represent that any license, either express or implied, is granted under any TI patent right, copyright, mask work right, or other TI intellectual property right relating to any combination, machine, or process in which TI products or services are used. Information published by TI regarding third-party products or services does not constitute a license from TI to use such products or services or a warranty or endorsement thereof. Use of such information may require a license from a third party under the patents or other intellectual property of the third party, or a license from TI under the patents or other intellectual property of TI.

Reproduction of information in TI data books or data sheets is permissible only if reproduction is without alteration and is accompanied by all associated warranties, conditions, limitations, and notices. Reproduction of this information with alteration is an unfair and deceptive business practice. TI is not responsible or liable for such altered documentation.

Resale of TI products or services with statements different from or beyond the parameters stated by TI for that product or service voids all express and any implied warranties for the associated TI product or service and is an unfair and deceptive business practice. TI is not responsible or liable for any such statements.

Following are URLs where you can obtain information on other Texas Instruments products and application solutions:

Products		Applications	
Amplifiers	amplifier.ti.com	Audio	www.ti.com/audio
Data Converters	dataconverter.ti.com	Automotive	www.ti.com/automotive
DSP	dsp.ti.com	Broadband	www.ti.com/broadband
Interface	interface.ti.com	Digital Control	www.ti.com/digitalcontrol
Logic	logic.ti.com	Military	www.ti.com/military
Power Mgmt	power.ti.com	Optical Networking	www.ti.com/opticalnetwork
Microcontrollers	microcontroller.ti.com	Security	www.ti.com/security
Low Power Wireless	www.ti.com/lpw	Telephony	www.ti.com/telephony
		Video & Imaging	www.ti.com/video
		Wireless	www.ti.com/wireless

Mailing Address: Texas Instruments
Post Office Box 655303 Dallas, Texas 75265