

GTM CORPORATION

ISSUED DATE :2006/05/16
REVISED DATE :

GL2137

750mA CMOS Low Dropout Voltage Regulator

Description

The GL2137 series of positive, linear regulators feature low quiescent current (30µA typ.) with low dropout voltage, making them ideal for battery applications.

These rugged devices have both Thermal Shutdown, and Current Fold-back to prevent device failure under the "Worst" of operating conditions.

The GL2137 is stable with an output capacitance of 2.2µF or greater.

Features

- Very Low Dropout Voltage
- Guaranteed 750mA output
- Over-Temperature Shutdown
- Current Limiting
- Short Circuit Current Fold-back
- Highly Accurate ± 1.5%
- Low Temperature Coefficient

Applications

- Battery Powered Widgets
- Instrumentation
- Wireless Devices
- PC Peripherals
- Portable Electronics

Functional Block Diagram

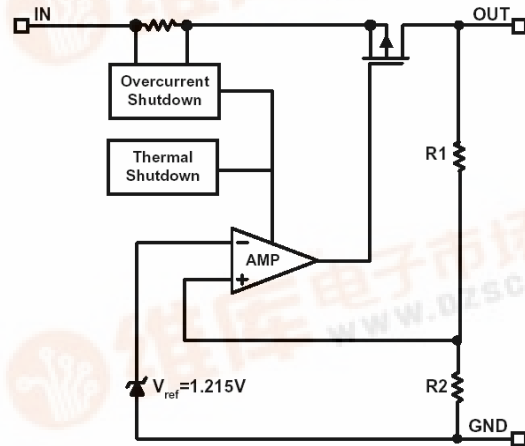

Package Dimensions

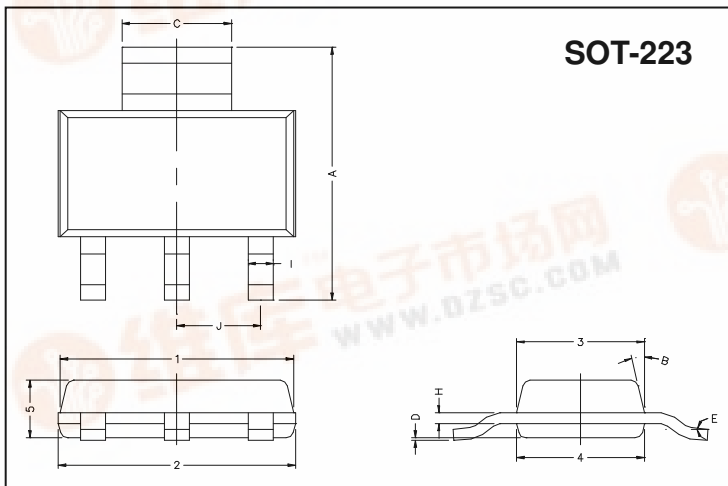

SOT-223

Marking :

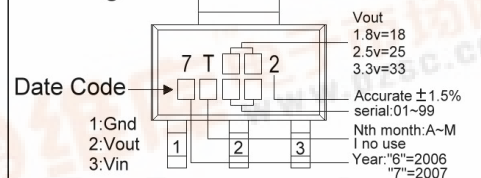

REF.	Millimeter		REF.	Millimeter	
	Min.	Max.		Min.	Max.
A	6.70	7.30	B	13°TYP.	
C	2.90	3.10	J	2.30 REF.	
D	0.02	0.10	1	6.30	6.70
E	0°	10°	2	6.30	6.70
I	0.60	0.80	3	3.30	3.70
H	0.25	0.35	4	3.30	3.70
			5	1.40	1.80

Typical Application Circuit

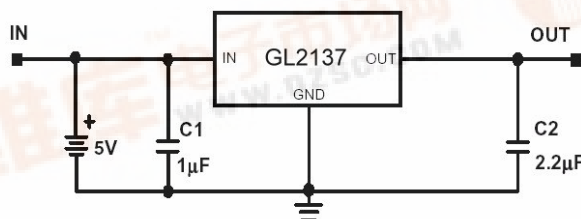

Absolute Maximum Ratings

Parameter	Symbol	Ratings	Unit
Input Max Voltage	V _{IN}	8	V
Output Current	I _{OUT}	1	A
Output Voltage	V _{OUT}	1.5~3.8	V
Operating Ambient Temperature	T _{opr}	-40 ~ +85	°C
Junction Temperature	T _j	-40 ~ +125	°C
Maximum Junction Temperature	T _{j Max}	150	°C
Thermal Resistance	θ _{jc}	160	°C/W
Internal Power Dissipation (ΔT=100°C)	PD	625	mW
EDS Classification		B	

Electrical Characteristics V_{IN}=V_{OUT}(T)+2V, T_a=25°C unless otherwise noted

Parameter	Symbol	Condition	Min	TYP	Max	Unit	
Output Voltage	V _{OUT} (E) (Note1)	I _o =1mA	-1.5%	V _{OUT} (T) (Note2)	1.5%	V	
Output Current	I _o	V _o >1.2V	750	-	-	mA	
Current Limit	I _{LM}	V _o >1.2V	750	850	-	mA	
Load Regulation	REG _{LOAD}	V _{IN} =V _{OUT} (T)+2V, I _o =1mA to 750mA	-1	0.2	1	%	
Dropout Voltage	V _{DROPOUT}	I _o =750mA V _o =V _{OUT} (E)-2%	1.4V<V _{OUT} (T)≤2.0V	-	-	1400	mV
			2.0V<V _{OUT} (T)≤2.8V	-	-	800	
			2.8V<V _{OUT} (T)	-	-	600	
Quiescent Current	I _Q	V _{IN} = V _{OUT} (T)+2V, I _o =0mA	-	30	50	μA	
Ground Pin Current	I _{IGND}	V _{IN} = V _{OUT} (T)+2V, I _o =1mA~750mA	-	35	-	μA	
Line Regulation	REG _{LINE}	I _o =1mA V _{IN} =V _{OUT} (T)+1 to V _{OUT} (T)+2	1.4V<V _{OUT} (T)≤2.0V	-0.15	-	0.15	%
			2.0V<V _{OUT} (T)<4.0V	-0.1	0.02	0.1	
Input Voltage	V _{IN}		Note3	-	7	V	
Over Temperature Shutdown	OTS		-	150	-	°C	
Over Temperature Hysteresis	OTH		-	30	-	°C	
Vo Temperature Coefficient	TC		-	30	-	ppm/°C	
Short Circuit Current	I _{SC}	V _{IN} =V _{OUT} (T)+1V, V _{OUT} <0.8V	-	300	600	mA	
Power Supply Rejection	PSRR	I _o =100mA C _o =2.2μF	f=1kHz	-	50	-	dB
			f=10kHz	-	20	-	
			f=100kHz	-	10	-	
Output Voltage Noise	eN	f=10Hz~100kHz, I _o =10mA, C _o =2.2μF	-	30	-	μVrms	

Note 1: V_{OUT}(E) =Effective Output Voltage (i.e. the output voltage when "V_{OUT}(T) + 2.0V" is provided at the V_{IN} pin while maintaining a certain I_{OUT} value).

2: V_{OUT}(T) =Specified Output Voltage

3: V_{IN}(MIN) =V_{OUT}+V_{DROPOUT}

Ordering Information (contd.)

Part Number	Marking	Output Voltage	Part Number	Marking	Output Voltage
GL2137-15	7T152 XXXX	1.5V	GL2137-18	7T182 XXXX	1.8V
GL2137-25	7T252 XXXX	2.5V	GL2137-27	7T272 XXXX	2.7V
GL2137-28	7T282 XXXX	2.8V	GL2137-29	7T292 XXXX	2.9V
GL2137-30	7T302 XXXX	3.0V	GL2137-31	7T312 XXXX	3.1V
GL2137-33	7T332 XXXX	3.3V	GL2137-34	7T342 XXXX	3.4V
GL2137-35	7T352 XXXX	3.5V	GL2137-36	7T362 XXXX	3.6V
GL2137-3.7	7T372 XXXX	3.7V	GL2137-38	7T382 XXXX	3.8V
GL2137-2H	7T2H2 XXXX	2.85V			

Detailed Description

The GL2137 series of COMS regulators contain a PMOS pass transistor, voltage reference, error amplifier, over-current protection, and thermal shutdown.

The P-channel pass transistor receives data from the error amplifier, over-current shutdown, and thermal protection circuits. During normal operation, the error amplifier compares the output voltage to a precision reference. Over-current and Thermal shutdown circuits become active when the junction temperature exceeds 150°C, or the current exceeds 750mA. During thermal shutdown, the output voltage remains low. Normal operation is restored when the junction temperature drops below 120°C.

The GL2137 switches from voltage mode to current mode when the load exceeds the rated output current. This prevents over-stress. The GL2137 also incorporates current fold-back to reduce power dissipation when the output is short circuited. This feature becomes active when the output drops below 0.8V and reduces the current flow by 65%. Full current is restored when the voltage exceeds 0.8V.

External Capacitors

The GL2137 is stable with an output capacitance to ground of 2.2µF or greater. Ceramic capacitors have the lowest ESR, and will offer the best AC performance. Conversely, Aluminum Electrolytic capacitors exhibit the highest ESR, resulting in the poorest AC response. Unfortunately, large value ceramic capacitors are comparatively expensive. One option is to parallel a 0.1µF ceramic capacitor with a 10µF Aluminum Electrolytic. The benefit is low ESR, high capacitance, and low overall cost.

A second capacitor is recommended between the input and ground to stabilize V_{in} . The input capacitor should be at least 0.1µF to have a beneficial effect.

All capacitors should be placed in close proximity to the pins. A "Quiet" ground termination is desirable. This can be achieved with a "Star" connection.

Characteristics Curve

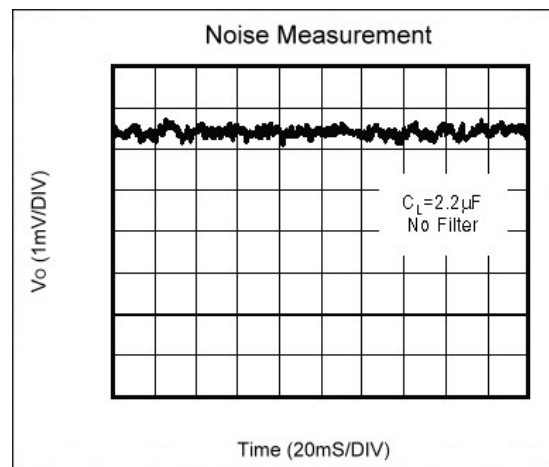
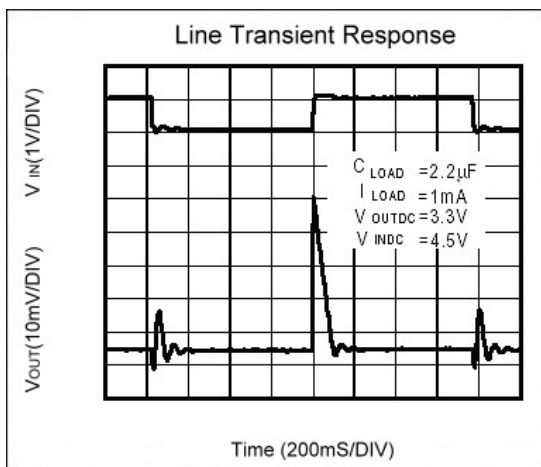
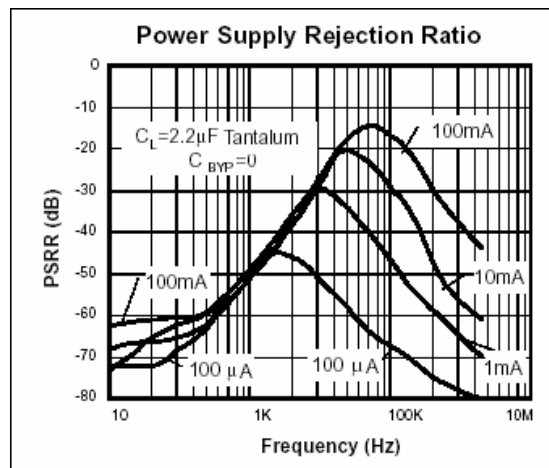
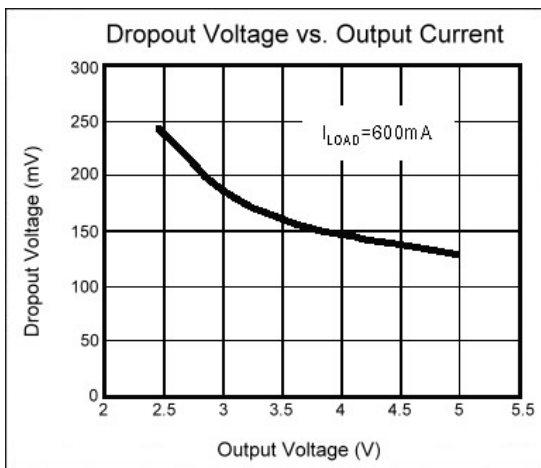
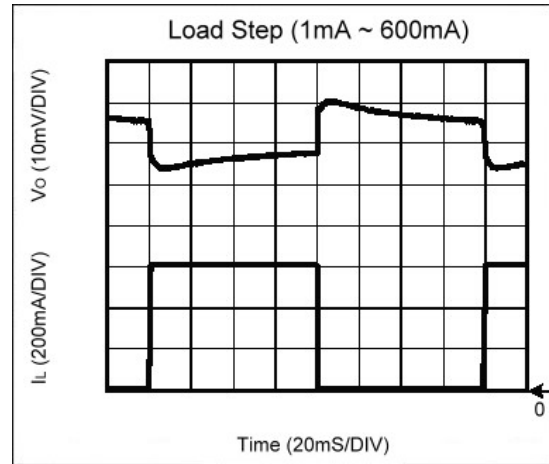
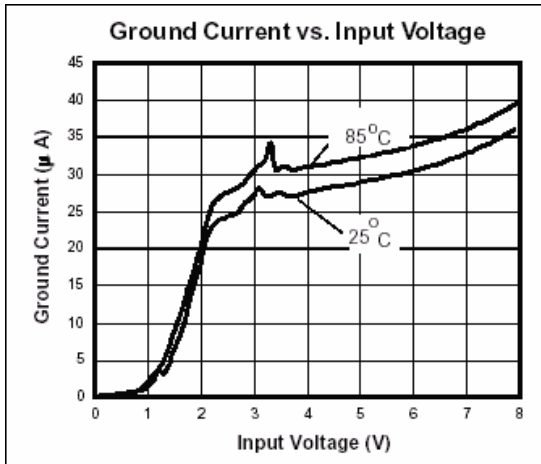

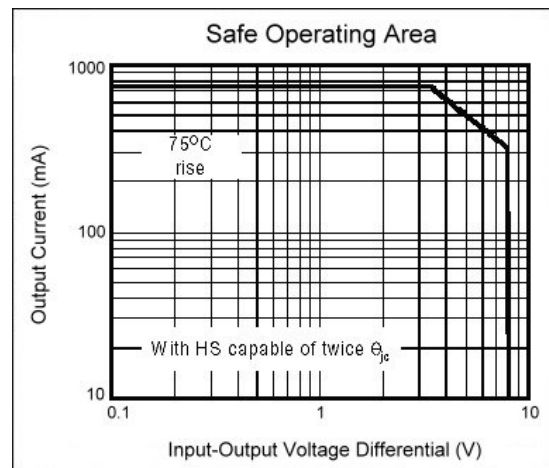
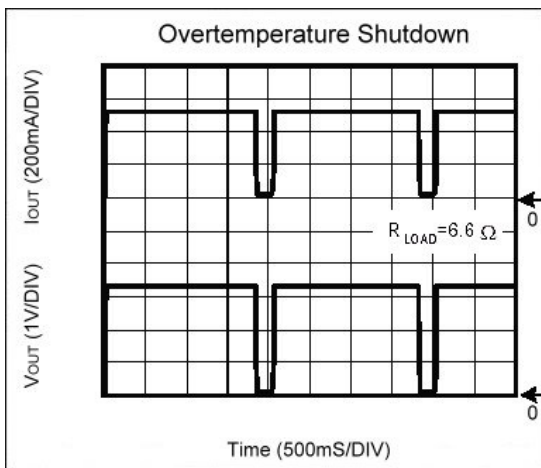
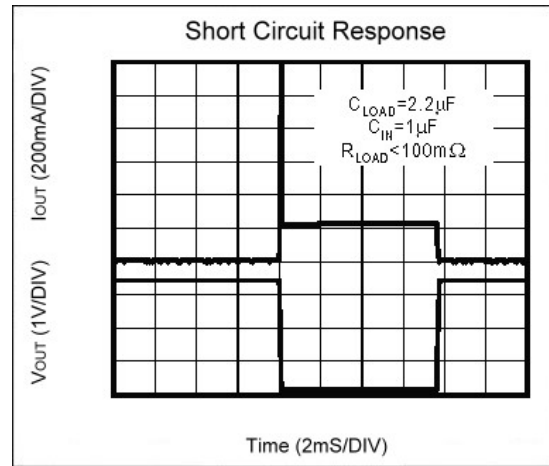
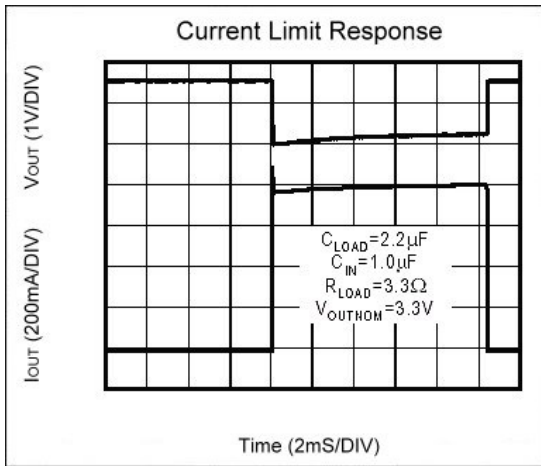

Important Notice:

- All rights are reserved. Reproduction in whole or in part is prohibited without the prior written approval of GTM.
- GTM reserves the right to make changes to its products without notice.
- GTM semiconductor products are not warranted to be suitable for use in life-support Applications, or systems.
- GTM assumes no liability for any consequence of customer product design, infringement of patents, or application assistance.

Head Office And Factory:

- **Taiwan:** No. 17-1 Tatung Rd. Fu Kou Hsin-Chu Industrial Park, Hsin-Chu, Taiwan, R. O. C.
- TEL : 886-3-597-7061 FAX : 886-3-597-9220, 597-0785
- **China:** (201203) No.255, Jang-Jiang Tsai-Lueng RD. , Pu-Dung-Hsin District, Shang-Hai City, China
- TEL : 86-21-5895-7671 ~ 4 FAX : 86-21-38950165