



# GM7110

## 1A STEP-DOWN VOLTAGE SWITCHING REGULATOR

### Description

GM7110 of regulators provides all the active functions for a step- down (buck) switching regulator, and drives 1A load with excellent line and load regulation.

GM7110 is available in fixed output volt ages of 3.3V, 5V, 12V, 15V and a versatile Adjustable output version. These regulators are simple to use and require a minimum number of external components.

Features include internal frequency compensation and a fixed- frequency oscillator. GM7110 high-efficiency replacement for popular three-terminal linear regulators, and is requiring a smaller heat sink or even no heat sink.

GM7110 performs well with standard inductors from several manufacturers, and simplifying the design of switch-mode power supplies. GM7110 guarantees  $\pm 4\%$  tolerance on output voltage within specified input voltages and output load conditions, and  $\pm 10\%$  on the oscillator frequency.

External shutdown is included with 50 uA(typical) standby current. The output switch has cycle-by-cycle current limiting as well as thermal shutdown for full protection under fault conditions.

### Features

- ◆ 3.3V, 5V, 12V, 15V and Adjustable output versions
- ◆ Adjustable version output voltage range 1.23V to 37V  $\pm 4\%$  max over line and load conditions
- ◆ 1A output current
- ◆ Requires Only 4 External Components
- ◆ High Efficiency
- ◆ TTL shutdown capability and low power standby mode
- ◆ Thermal shutdown, current limit protection
- ◆ Uses standard inductors
- ◆ 52 kHz fixed frequency internal oscillator

### Application

Pre-regulator for linear regulators  
High-efficiency step-down buck regulator

On-card/ board switching regulators  
Positive to negative converter (buck-boost)

### TYPICAL APPLICATION

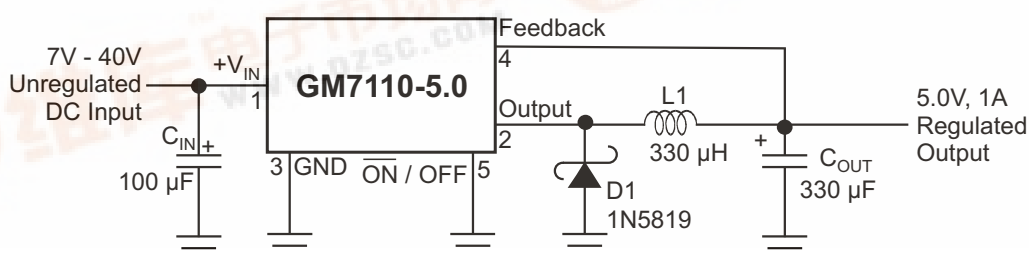

#### ◆ MARKING INFORMATION & PIN CONFIGURATIONS

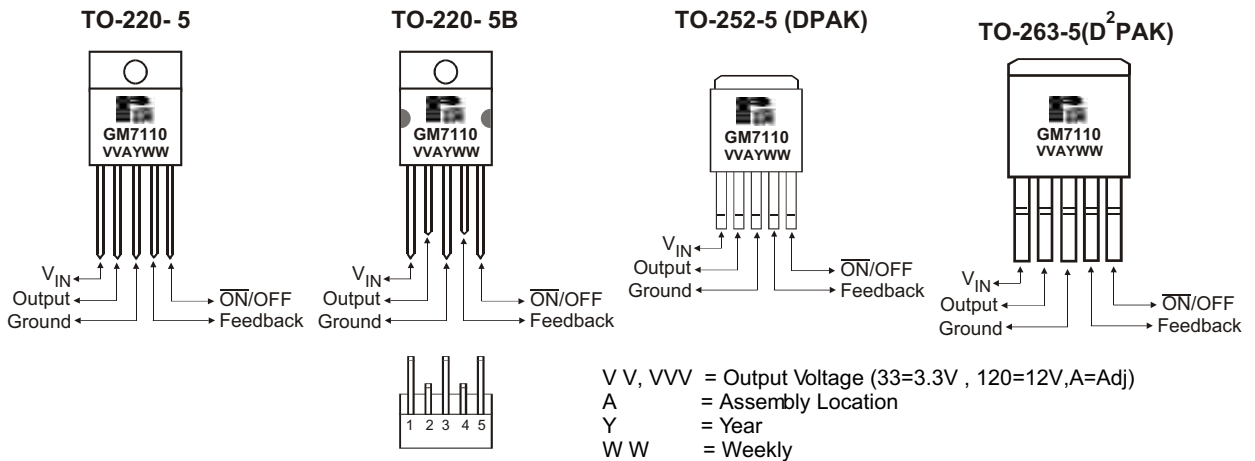

#### ◆ ORDERING INFORMATION

Ordering Number	Output Voltage	Package	Shipping
GM7110-ATB5T	A d j	TO-220-5	50 Units / Tube
GM7110-ATB5BT	A d j	TO-220-5B	50 Units / Tube
GM7110-ATA5R	A d j	TO-263-5	800 Units/ Tape & Reel
GM7110-ATA5T	A d j	TO-263-5	50 Units / Tube
GM7110-3.3TB5T	3.3	TO-220-5	50 Units / Tube
GM7110-3.3TB5BT	3.3	TO-220-5B	50 Units / Tube
GM7110-3.3TA5R	3.3	TO-263-5	800 Units/ Tape & Reel
GM7110-3.3TA5T	3.3	TO-263-5	50 Units / Tube
GM7110-5.0TB5T	5.0	TO-220-5	50 Units / Tube
GM7110-5.0TB5BT	5.0	TO-220-5B	50 Units / Tube
GM7110-5.0TA5R	5.0	TO-263-5	800 Units/ Tape & Reel
GM7110-5.0TA5T	5.0	TO-263-5	50 Units / Tube
GM7110-5.0TC5T	5.0	TO-252-5	80 Units/ Tube
GM7110-5.0TC5R	5.0	TO-252-5	2,500 Units/ Tape & Reel
GM7110-12TB5T	12	TO-220-5	50 Units / Tube
GM7110-12TB5BT	12	TO-220-5B	50 Units / Tube
GM7110-12TA5R	12	TO-263-5	800 Units/ Tape & Reel
GM7110-12TA5T	12	TO-263-5	50 Units / Tube
GM7110-15TB5T	15	TO-220-5	50 Units / Tube
GM7110-15TB5BT	15	TO-220-5B	50 Units / Tube
GM7110-15TA5R	15	TO-263-5	800 Units/ Tape & Reel
GM7110-15TA5T	15	TO-263-5	50 Units / Tube

\* TB5B: Bent and Staggered Leads of TO-220 package

\*\* For detail Ordering Number identification, please see last page.

#### ◆ ABSOLUTE MAXIMUM RATINGS

PARAMETER	VALUE	UNIT
Maximum Supply Voltage	45	V
$\overline{\text{ON}}/\text{OFF}$ Pin Input Voltage	$-0.3 \leq V \leq V_{\text{IN}}$	V
Output Voltage to Ground (Steady State)	-1.0	V
Power Dissipation	Internally Limited	-
Storage Temperature Range	-65 to + 150	°C
Maximum Junction Temperature	+150	°C
Lead Temperature (Soldering, 10 sec.)	+260	°C

#### ◆ RECOMMENDED OPERATING CONDITIONS

PARAMETER	VALUE	UNIT
Temperature Range	$-40 \leq T_J \leq 125$	°C
Supply Voltage	40	V

#### ◆ BLOCK DIAGRAM

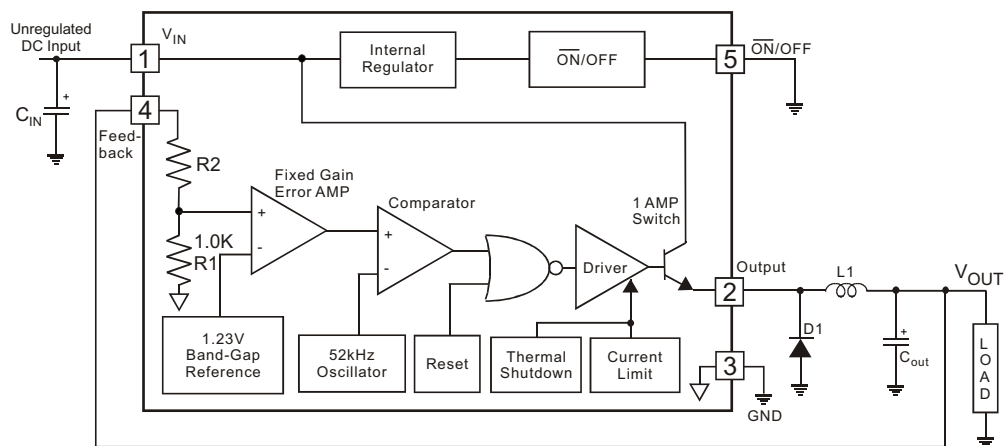

$V_{\text{OUT}}$   
 3.3V, R2 = 1.7K  
 5V, R2 = 3.1K  
 12V, R2 = 8.84K  
 15V, R2 = 11.3K  
 For ADJ. Version  
 R1 = Open, R2 = 0

#### ◆ ELECTRICAL CHARACTERISTICS: GM7110-3.3

(Specifications with standard type face are for  $T_J = 25^\circ\text{C}$ , and those with **boldface type** apply over full Operating Temperature Range)

Parameter	Conditions	Symbol	Min	Typ	Max	Unit
Output Voltage	$V_{IN} = 12\text{V}, I_{LOAD} = 0.2\text{A}$	$V_{OUT}$	3.234	3.3	3.366	V
Output Voltage	$4.75\text{V} \leq V_{IN} \leq 40\text{V}, 0.2\text{A} \leq I_{LOAD} \leq 1\text{A}$	$V_{OUT}$	3.168/ <b>3.135</b>	3.3	3.432/ <b>3.465</b>	V
Efficiency	$V_{IN} = 12\text{V}, I_{LOAD} = 1\text{A}$		-	75	-	%

#### ◆ ELECTRICAL CHARACTERISTICS: GM7110-5.0

(Specifications with standard type face are for  $T_J = 25^\circ\text{C}$ , and those with **boldface type** apply over full Operating Temperature Range)

Parameter	Conditions	Symbol	Min	Typ	Max	Unit
Output Voltage	$V_{IN} = 12\text{V}, I_{LOAD} = 0.2\text{A}$	$V_{OUT}$	4.900	5.0	5.100	V
Output Voltage	$8\text{V} \leq V_{IN} \leq 40\text{V}, 0.2\text{A} \leq I_{LOAD} \leq 1\text{A}$	$V_{OUT}$	4.800/ <b>4.750</b>	5.0	5.200/ <b>5.250</b>	V
Efficiency	$V_{IN} = 12\text{V}, I_{LOAD} = 1\text{A}$		-	77	-	%

#### ◆ ELECTRICAL CHARACTERISTICS: GM7110-12

(Specifications with standard type face are for  $T_J = 25^\circ\text{C}$ , and those with **boldface type** apply over full Operating Temperature Range)

Parameter	Conditions	Symbol	Min	Typ	Max	Unit
Output Voltage	$V_{IN} = 25\text{V}, I_{LOAD} = 0.2\text{A}$	$V_{OUT}$	11.76	12.0	12.24	V
Output Voltage	$15\text{V} \leq V_{IN} \leq 40\text{V}, 0.2\text{A} \leq I_{LOAD} \leq 1\text{A}$	$V_{OUT}$	11.52/ <b>11.40</b>	12.0	12.48/ <b>12.60</b>	V
Efficiency	$V_{IN} = 15\text{V}, I_{LOAD} = 1\text{A}$		-	88	-	%

#### ◆ ELECTRICAL CHARACTERISTICS: GM7110-15

(Specifications with standard type face are for  $T_J = 25^\circ\text{C}$ , and those with **boldface type** apply over full Operating Temperature Range)

Parameter	Conditions	Symbol	Min	Typ	Max	Unit
Feedback Voltage	$V_{IN} = 30\text{V}, I_{LOAD} = 0.2\text{A}$	$V_{OUT}$	14.70	15.0	15.30	V
Feedback Voltage	$18\text{V} \leq V_{IN} \leq 40\text{V}, 0.2\text{A} \leq I_{LOAD} \leq 1\text{A}$	$V_{OUT}$	14.40/ <b>14.25</b>	15.0	15.60/ <b>15.75</b>	V
Efficiency	$V_{IN} = 18\text{V}, I_{LOAD} = 1\text{A}$		-	88	-	%

#### ◆ ELECTRICAL CHARACTERISTICS: GM7110-ADJ

(Specifications with standard type face are for  $T_J = 25^\circ\text{C}$ , and those with **boldface type** apply over full Operating Temperature Range)

Parameter	Conditions	Symbol	Min	Typ	Max	Unit
Feedback Voltage	$V_{IN} = 12\text{V}, I_{LOAD} = 0.2\text{A}, V_{OUT} = 5\text{V}$	$V_{OUT}$	1.217	1.230	1.243	V
Feedback Voltage	$8\text{V} \leq V_{IN} \leq 40\text{V}, 0.2\text{A} \leq I_{LOAD} \leq 1\text{A}$ $V_{OUT} = 5\text{V}$	$V_{OUT}$	1.193/ <b>1.180</b>	1.230	1.267/ <b>1.280</b>	V
Efficiency	$V_{IN} = 12\text{V}, I_{LOAD} = 1.0\text{A}, V_{OUT} = 5\text{V}$		-	77	-	%

### ◆ ELECTRICAL CHARACTERISTICS: All Output Voltage Versions

(Specifications with standard type face are for  $T_J = 25^\circ\text{C}$ , and those with **boldface type** apply over full Operating Temperature Range. Unless otherwise specified,  $V_{IN} = 12\text{V}$  for the 3.3V, 5.0V and ADJ version,  $V_{IN} = 25\text{V}$  for 12V version, and  $V_{IN} = 30\text{V}$  for 15V version.  $I_{LOAD} = 500\text{mA}$ )

Parameter	Conditions	Symbol	Min	Typ	Max	Unit
Feedback Bias Current	$V_{OUT} = 5\text{V}$ (Adjustable Version Only)	$I_{FB}$	-	50	100 / <b>500</b>	nA
Oscillator Frequency	(Note 11)	$F_O$	<b>47 / 42</b>	52	<b>58 / 63</b>	kHz
Saturation Voltage	$I_{OUT} = 1\text{A}$ (Notes 4)	$V_{SAT}$	-	0.9	<b>1.2 / 1.4</b>	V
Max Duty Cycle (ON)	(Note 5)	$T_{DC}$	93	98	-	%
Current Limit	(Note 4, 11)	$I_{CL}$	<b>1.7 / 1.3</b>	2.2	<b>3.0 / 3.2</b>	A
Output Leakage Current	(Notes 6, 7) Output = 0 V Output = -1V	$I_{OL}$	- -	- 7.5	2 30	mA
Quiescent Current	(Note 6)	$I_Q$	-	5	10	mA
Standby Quiescent Current	$\overline{\text{ON}}/\text{OFF}$ Pin = 5V (OFF)	$I_{STBY}$	-	50	200	A
Thermal Resistance	TO-220 Package, Junction to Ambient (Note 8)	$J_A$	-	65	-	$^\circ\text{C}/\text{W}$
	TO-220 Package, Junction to Ambient (Note 8)	$J_A$	-	45	-	
	TO-220, TO-263, Package, Junction to Case	$J_C$	-	2	-	
	TO-252 Package, Junction to Case	$J_C$	-	6	-	
	TO-263 Package, Junction to Ambient (Note 10)	$J_A$	-	37	-	
$\overline{\text{ON}}/\text{OFF}$ Pin	$V_{OUT} = 0\text{V}$	$V_{IH}$	<b>2.2 / 2.4</b>	1.4	-	V
Logic Input Level	$V_{OUT} = \text{Nominal Output Voltage}$	$V_{IL}$	-	1.2	<b>1.0 / 0.8</b>	V
$\overline{\text{ON}}/\text{OFF}$ Pin Input Current	$\overline{\text{ON}}/\text{OFF}$ Pin = 5V (OFF)	$I_{IH}$	-	12	30	A
	$\overline{\text{ON}}/\text{OFF}$ Pin = 0V (ON)	$I_{IL}$	-	0	10	A

**Note 1:** Absolute Maximum Ratings indicate limits beyond which damage to the device may occur. Operating Ratings indicate conditions for which the device is intended to be functional, but do not guarantee specific performance limits. Guaranteed specifications and Test conditions are shown in Electrical Characteristics.

**Note 2:** All limits guaranteed at  $25^\circ\text{C}$  (standard type face) and over full operating temperature range (bold type face). All  $25^\circ\text{C}$  limits are 100% production tested. All limits over full operating temperature range are guaranteed via correlation using standard Statistics Quality Control methods.

**Note 3:** External components such as the catch diode, inductor, input and output capacitors can affect switching regulator system performance. When the GM7110 is used as shown in the Figure 2 test circuit, system performance will be as shown in system parameters section of Electrical Characteristics.

**Note 4:** Output pin sourcing current. No diode, inductor or capacitor connected to output.

**Note 5:** Feedback pin removed from output and connected to 0V.

**Note 6:** Feedback pin removed from output and connected to +12V for the Adjustable, 3.3V, and 5V versions, and +25V for the 12V and 15V versions, to force the output transistor OFF.

**Note 7:**  $V_{IN} = 40\text{V}$

**Note 8:** Junction to ambient thermal resistance (no external heat sink) for the 5 lead TO-220 package mounted vertically, with  $\frac{1}{2}$  inch leads in a socket, or on a PC board with minimum copper area.

**Note 9:** Junction to ambient thermal resistance (no external heat sink) for the 5 lead TO-220 package mounted vertically, with  $\frac{1}{4}$  inch leads soldered to a PC board containing approximately 4 square inches of copper area surrounding the leads.

**Note 10:** If the TO-263 package is used, the thermal resistance can be reduced by increasing the PC board Copper area thermally connected to the package. Using 0.5 square inches of copper area,  $J_A$  is  $50^\circ\text{C}/\text{W}$ , with 1 square inch of copper area,  $J_A$  is  $37^\circ\text{C}/\text{W}$ , and with 1.6 or more square inches of copper area,  $J_A$  is  $32^\circ\text{C}/\text{W}$ .

**Note 11:** The oscillator frequency reduces to approximately 11 kHz in the event of an output short or an Overload which causes the regulated output voltage to drop approximately 40% from the nominal output voltage. This self-protection feature lowers the Average power dissipation of Gm7110 By lowering the minimum duty cycle from 5% down to approximately 2%.

#### ◆ TEST CIRCUIT AND LAYOUT GUIDELINES

Careful layout is important with any switching regulator. Rapidly switching currents associated with wiring inductance generate voltage transients, which can cause problems. To minimize inductance and ground loops, the lengths of the leads indicated by heavy lines in Figure 1 below should be kept as short as possible. Single-point grounding (as indicated in Figure 1) or ground plane construction should be used for best results. When using the Adjustable version, place the programming resistors as close as possible to GM7110, to keep the sensitive feedback wiring short.

**Figure 1(a). Fixed Output Voltage Versions**

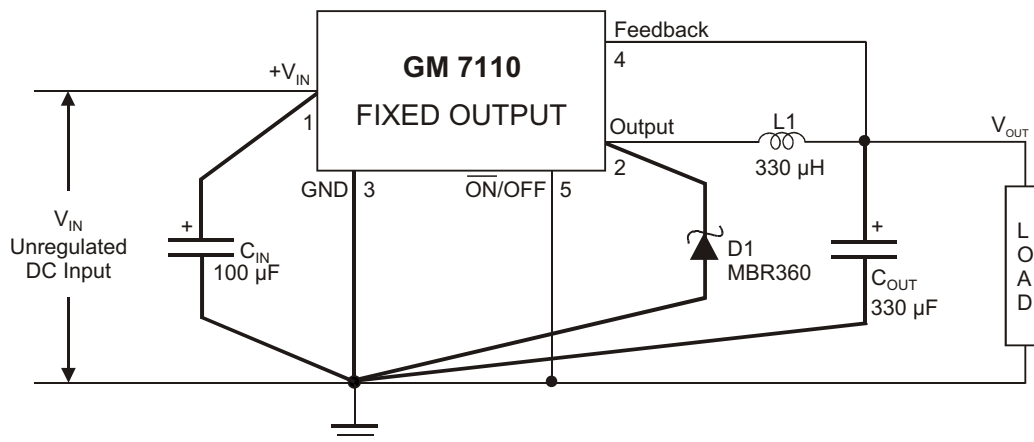

$C_{IN}$  - 100  $\mu$ F, 75V, Aluminum Electrolytic

$C_{OUT}$  - 330  $\mu$ F, 25V, Aluminum Electrolytic

D1 - Schottky, MBR360

L1 - 330  $\mu$ H, 3L Electronic Corp. TC-331M-1.0A- 5026

R1 - 2k, 0.1%

R2 - 6.12k, 0.1%

Figure 1(b).Adjustable Output Voltage Versions

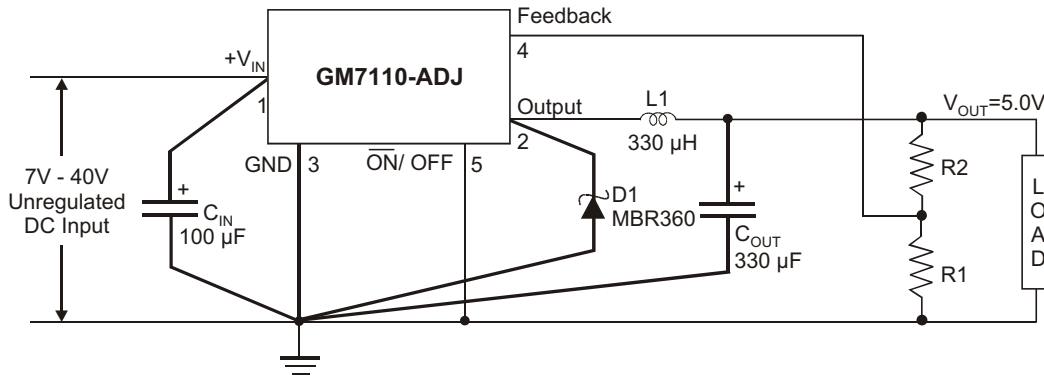

$$V_{OUT} = V_{REF} \left( 1 + \frac{R2}{R1} \right)$$

$$R2 = R1 \left( \frac{V_{OUT}}{V_{REF}} - 1 \right)$$

where  $V_{REF} = 1.23V$ ,  $R1$  between 1k and 5k.

#### ◆ Typical Performance Characteristics

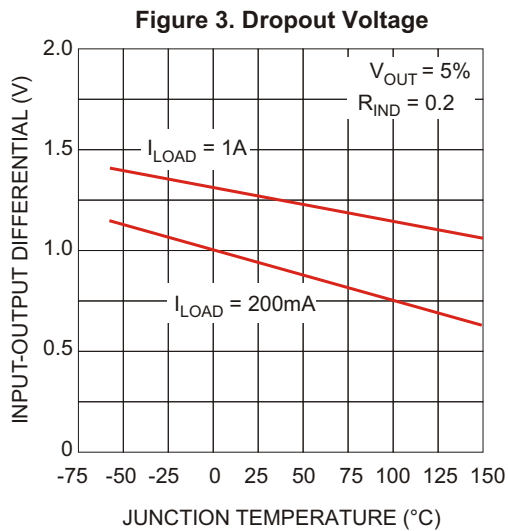
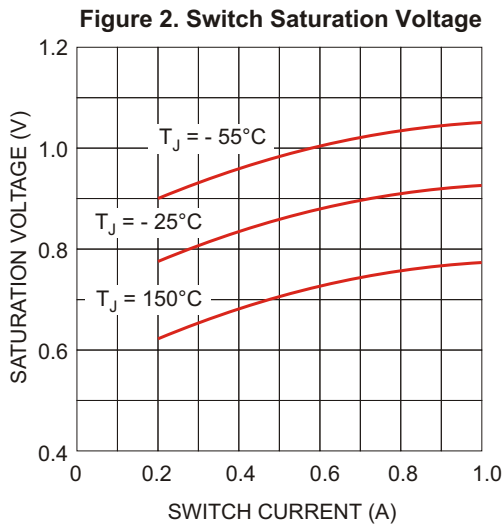



#### ◆ Typical Performance Characteristics

Figure 4. Quiescent Current

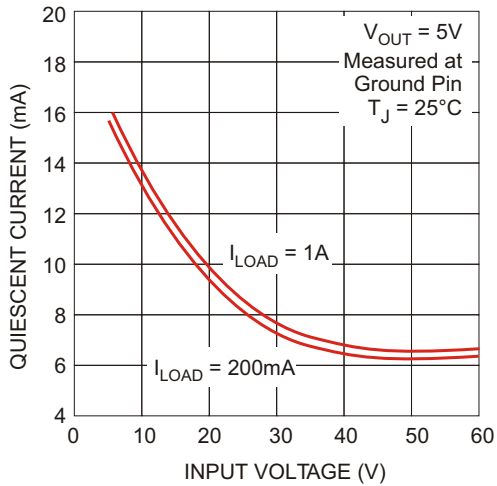

Figure 5. Maximum Power Dissipation(TO-263)

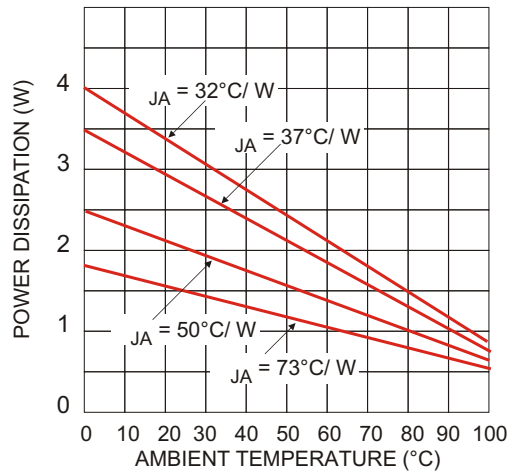

Figure 6. Minimum Operating Voltage

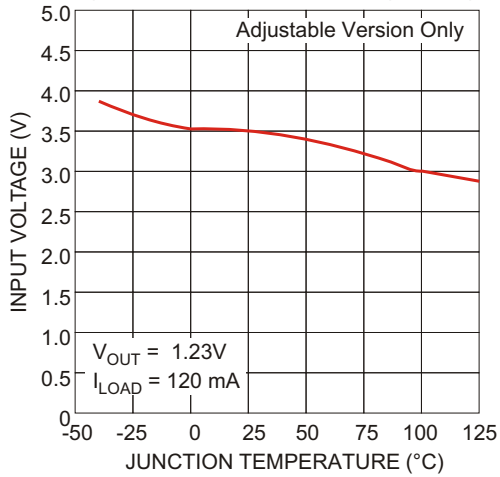
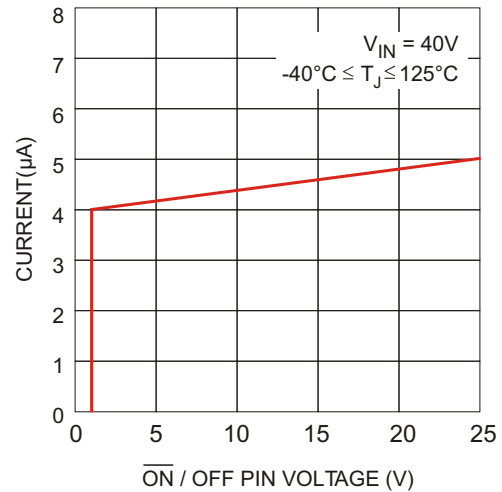
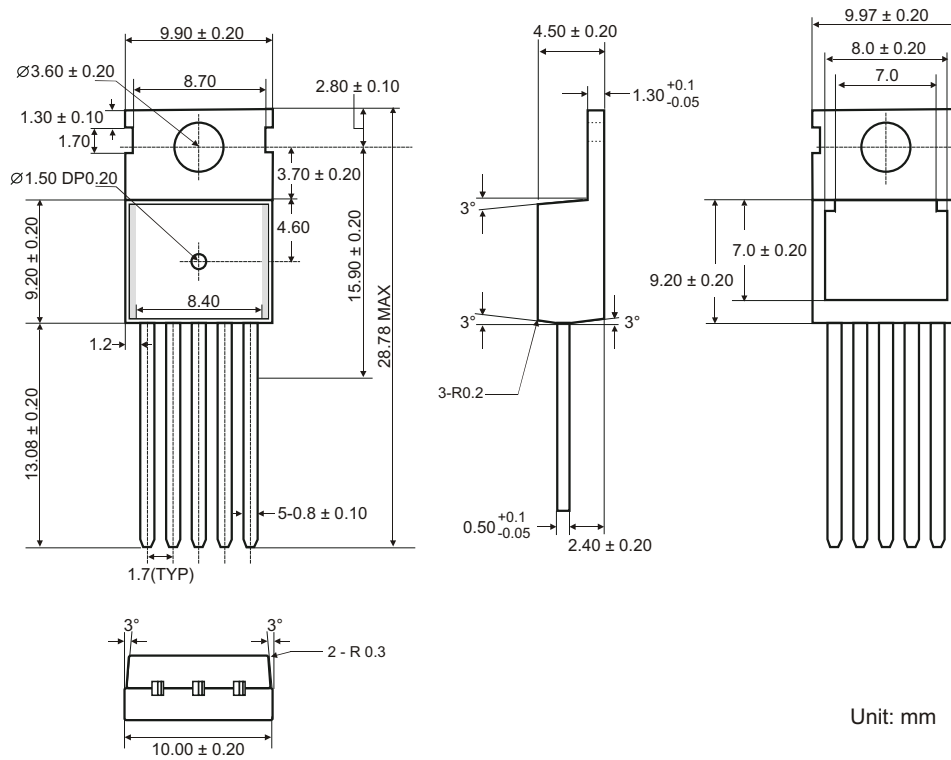

Figure 7.  $\overline{ON}$  / OFF Pin Current (Sinking)





#### ◆ TO-220-5 PACKAGE OUTLINE DIMENSIONS



#### ◆ TO-263-5 PACKAGE OUTLINE DIMENSIONS

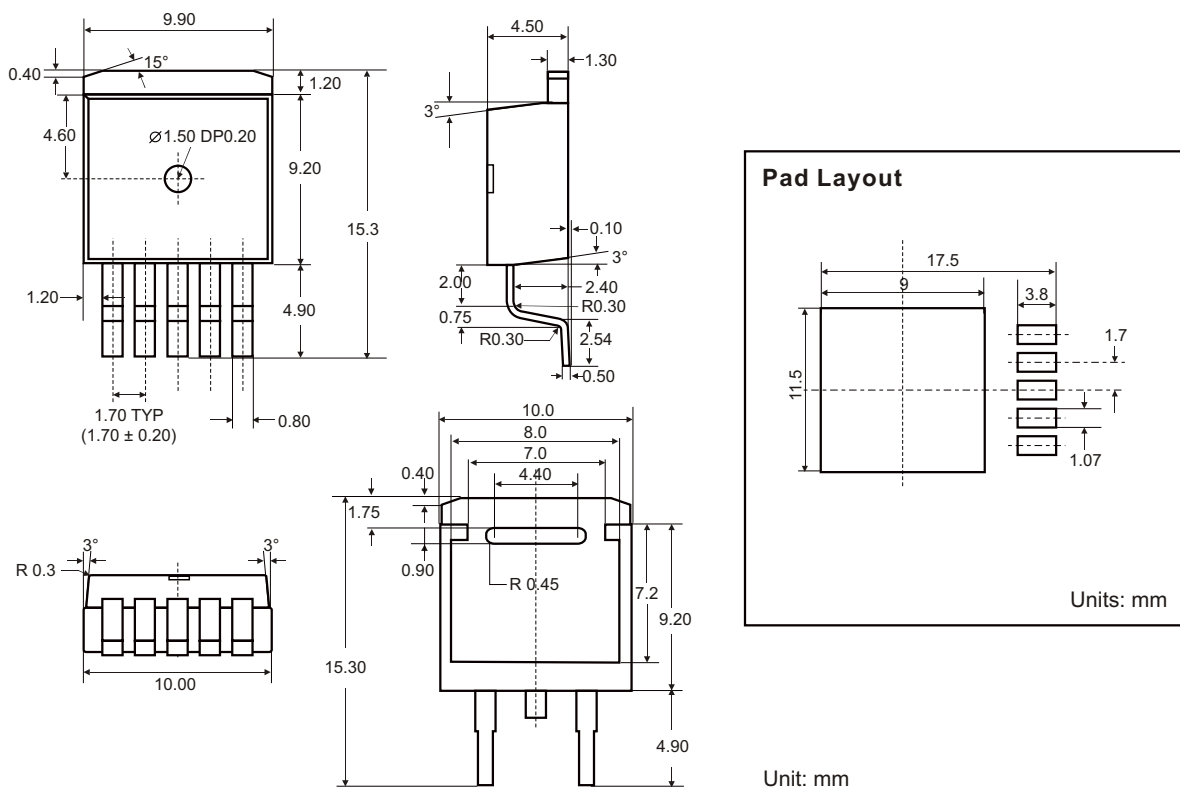

#### ◆ TO-220-5B PACKAGE OUTLINE DIMENSIONS

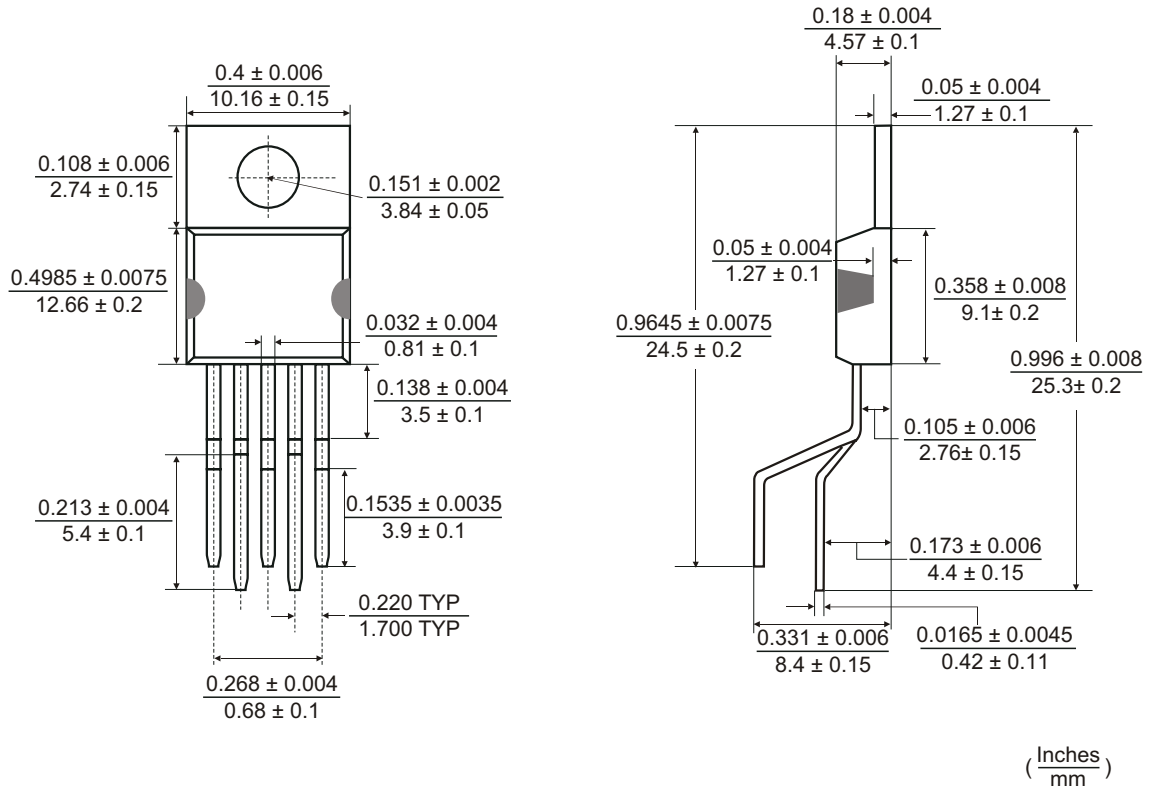

#### ◆ TO-252-5 PACKAGE OUTLINE DIMENSIONS

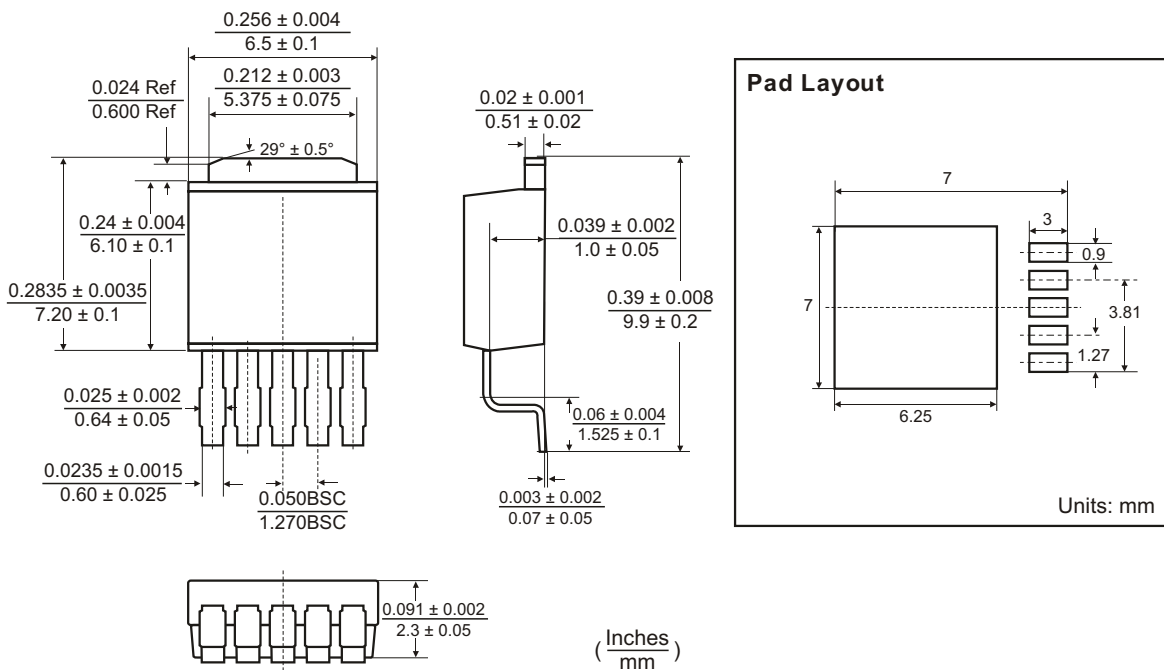

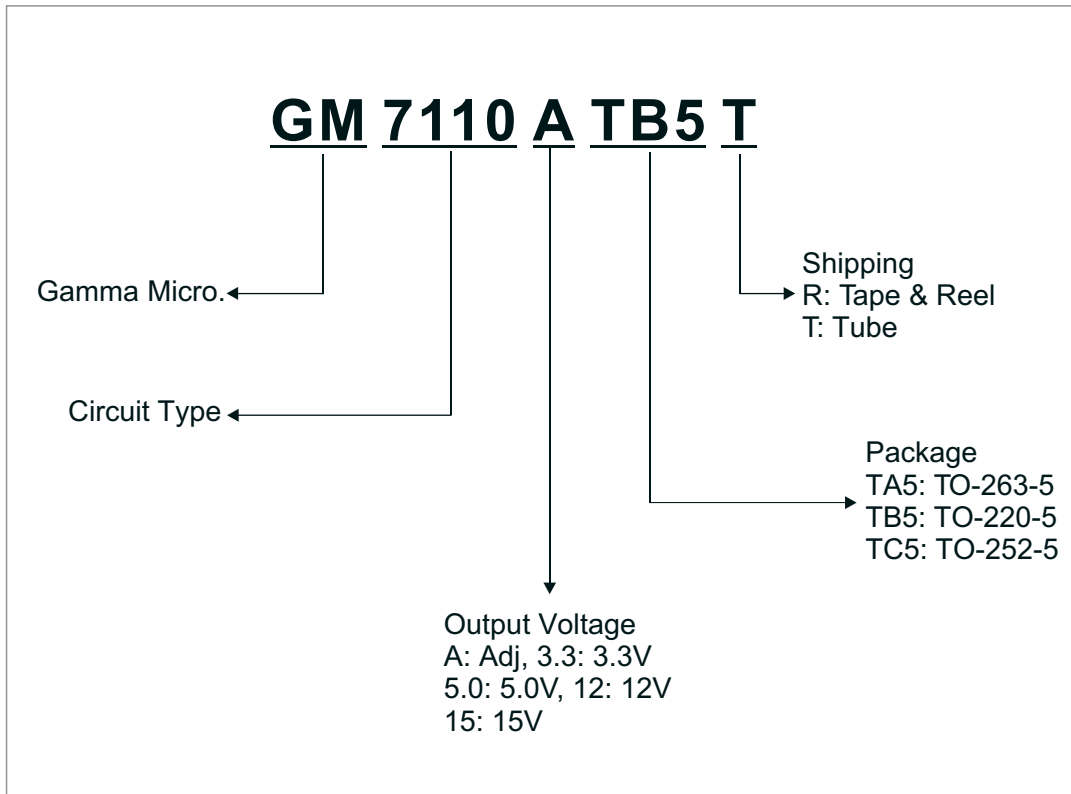

#### ◆ ORDERING NUMBER





---

GAMMA Micro, , and  are registered trademarks of GAMMA MICROELECTRONICS INC. GAMMA reserves the right to make changes without further notice to any products herein. Information provided herein is alleged to be exact and consistent and this publication surpasses and replaces all information previously supplied.

GAMMA makes no warranty the suitability of its products for any particular purpose, nor does GAMMA assume any liability arising out of the application or use of any product or circuit, and specifically disclaims any and all liability including without limitation special, consequential or incidental damages.

GAMMA products are not authorized for using as critical components in life support devices or systems