



GPJ20A~GPJ20M

SINGLE-PHASE BRIDGE RECTIFIER

VOLTAGE 50 to 1000 Volts **CURRENT** 20 Ampere

Recognized File #E157705

FEATURES

- Diffused Junction
- Low Forward Voltage Drop
- High Current Capability
- High Reliability
- High Surge Current Capability
- Ideal for Printed Circuit Boards
- Pb free product are available : 99% Sn above can meet RoHS environment substance directive request

MECHANICAL DATA

- Case: Molded plastic body
- Terminals: Plated Leads Solderable per MIL-STD-750, Method 2026
- Polarity: As Marked on Body
- Weight: 7.056 grams (approx.)
- Mounting Position: Any

KBJ Unit: inch (mm)

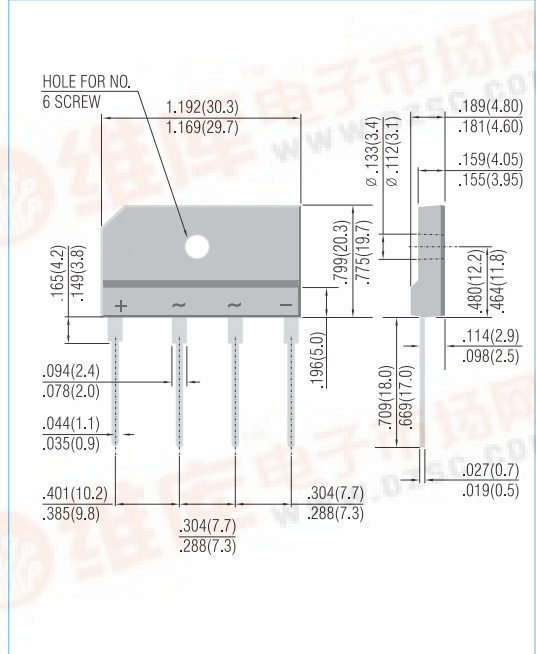

MAXIMUM RATINGS AND ELECTRICAL CHARACTERISTICS

Single Phase, half wave, 60Hz, resistive or inductive load.
For Capacitive load derate current by 20%.

PARAMETER	SYMBOL	GPJ20A	GPJ20B	GPJ20D	GPJ20G	GPJ20J	GPJ20K	GPJ20M	UNITS
Maximum Recurrent Peak Reverse Voltage	V_{RRM}	50	100	200	400	600	800	1000	V
Maximum RMS Bridge Input Voltage	V_{RMS}	35	70	140	280	420	560	700	V
Maximum DC Blocking Voltage	V_{DC}	50	100	200	400	600	800	1000	V
Average Rectified Output Current at $T_C=100\text{ }^\circ\text{C}$	$I_{F(AV)}$	20							A
I^2t Rating for fusing ($t < 8.3\text{ms}$)	I^2t	500							A^2sec
Peak Forward Surge Current single sine-wave superimposed on rated load (JEDEC method)	I_{FSM}	350							A
Maximum Instantaneous Forward Voltage Drop per element at 12.5A	V_F	1.1							V
Maximum Reverse Leakage Current at Rated @ $T_A=25\text{ }^\circ\text{C}$ Dc Blocking Voltage @ $T_C=100\text{ }^\circ\text{C}$	I_R	10 500							μA
Typical Thermal Resistance per leg (Note 1)	$R_{\theta JC}$	0.6							$^\circ\text{C/W}$
Operating Junction and Storage Temperature Range	T_{J}, T_{STG}	-55 to + 150							$^\circ\text{C}$

NOTES:

Device mounted on 220 x 220 x 1.6mm thick AL plate heatsink.





GPJ20A~GPJ20M

RATING AND CHARACTERISTIC CURVES

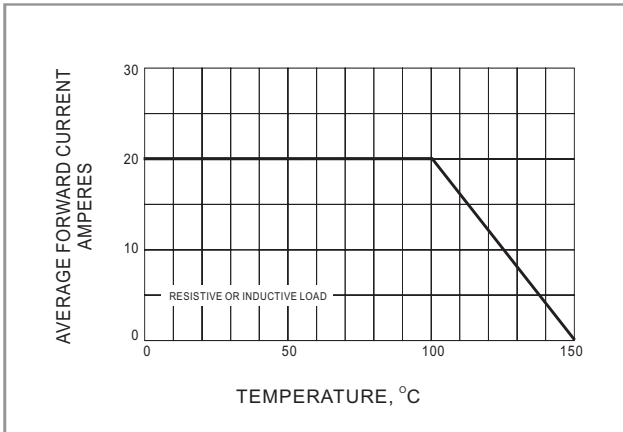

Fig. 1 - FORWARD CURRENT DERATING CURVE

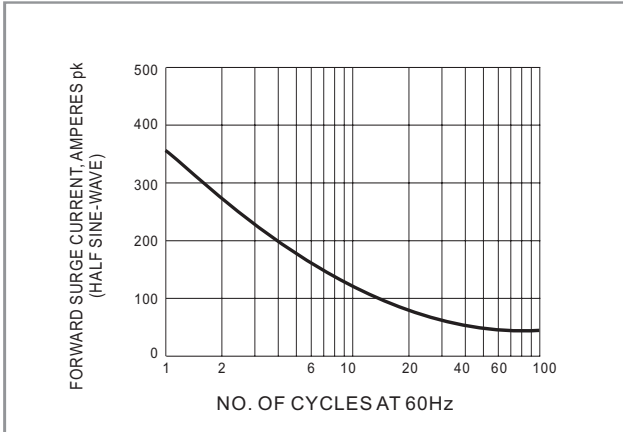

Fig. 2 - MAXIMUM NON-REPETITIVE SURGE CURRENT

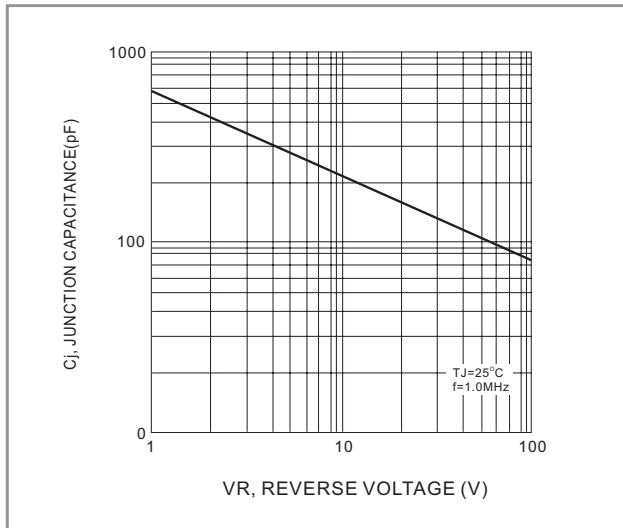

Fig. 3 - TYPICAL JUNCTION CAPACITANCE

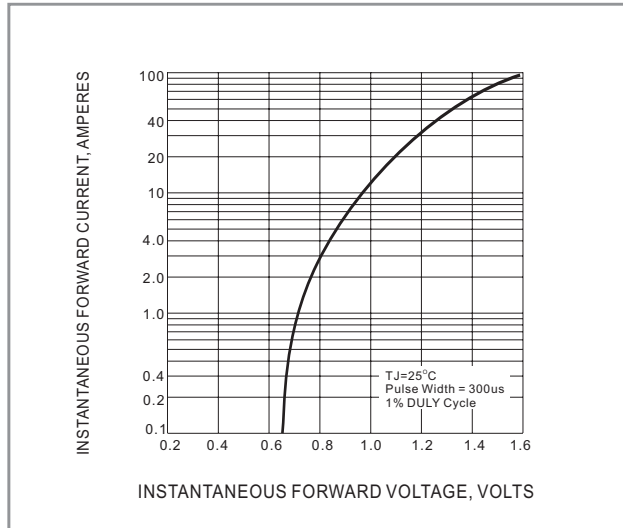

Fig. 4 - TYPICAL FORWARD CHARACTERISTICS PER ELEMENT