

GTM CORPORATION

ISSUED DATE :2003/08/11
REVISED DATE :2004/09/30B

GPLM358 DUAL OPERATIONAL AMPLIFIER

Description

The GPLM358 consists of two independent high gain, internally frequency compensated operational amplifier. It can be operated from a Single power supply and also split power supplies.

Features

- *Internally frequency compensated for unity gain.
- *Wide power supply range 3V – 32V.
- *Input common – mode voltage range include ground.
- *Large DC voltage gain.

Applications

- *General purpose amplifier.
- *Transducer amplifier.

Package Dimensions

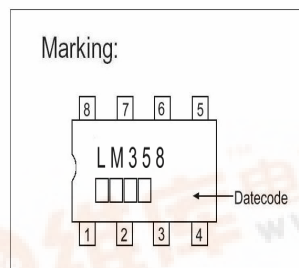
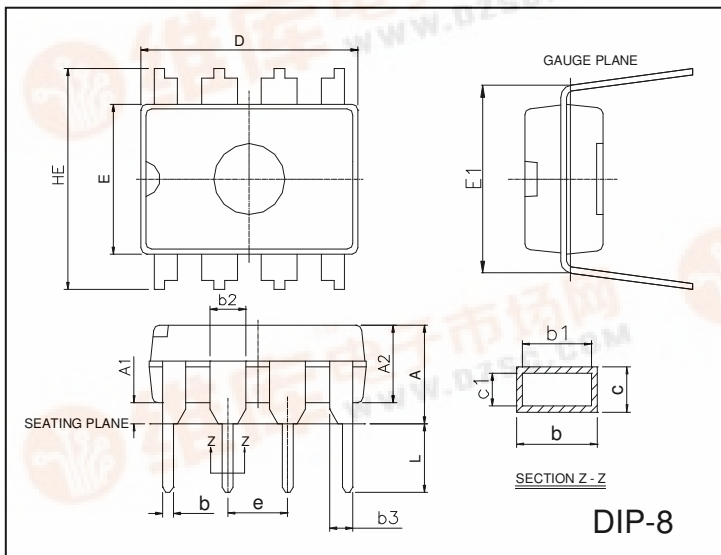

REF.	Millimeter		REF.	Millimeter	
	Min.	Max.		Min.	Max.
A	-	0.5334	c1	0.203	0.279
A1	0.381	-	D	9.017	10.16
A2	2.921	4.953	E	6.096	7.112
b	0.356	0.559	E1	7.620	8.255
b1	0.356	0.508	e	2.540 BSC	
b2	1.143	1.778	HE	-	10.92
b3	0.762	1.143	L	2.921	3.810
c	0.203	0.356			

Pin Configurations

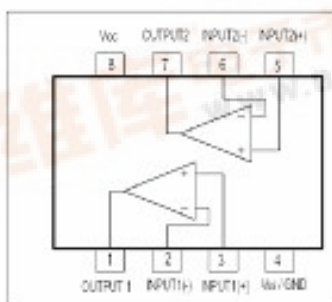

BLOCK DIAGRAM

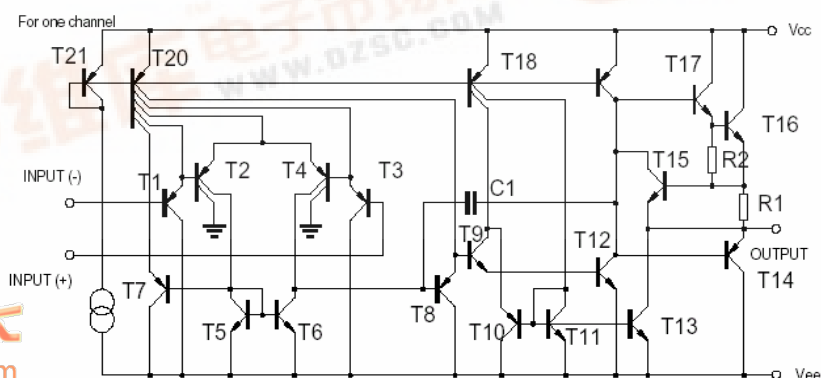

Absolute Maximum Ratings at Ta = 25°C

Parameter	Symbol	VALUE	Unit
Supply Voltage	Vcc	+ -16 or 32	V
Differential Input Voltage	VI(DIFF)	+ -32	V
Input Voltage	VI	-0.3 ~+32	V
Output Short to Ground		Continuous	
Operating Temperature Range	TOPR	0~+70	°C
Storage Temperature Range	TSTG	-65~+150	°C

Electrical Characteristics (Vcc=5.0V VEE=GND,TA=25°C, unless otherwise specified)

Parameter	SYMBOL	Test Conditions	Min	Typ.	Max.	Unit
Input Offset Voltage	VIO	VCM=0V to VCC-1.5V VO(P)=1.4V,RS=0Ω		2.9	7.0	mV
Input Offset Current	IIO			5	50	nA
Input Bias Current	IBIAS			45	250	nA
Input Common Mode Voltage	VI(R)	VCC=30V	0		VCC-1.5	V
Power Supply Current	ICC	RL=∞, VCC=30V		0.8	2.0	mA
		RL=∞, Full Temperature	-	0.5	1.2	mA
Large Signal Voltage Gain	GV	VCC=15V,RL>=2KΩ VO(P)=1V to 11V	25	100	-	V/mV
Output Voltage Swing	VO(H)	VCC=30V,RL=2KΩ	26			V
		VCC=30V,RL=10KΩ	27	28		V
	VO(L)	VCC=5V,RL>=10KΩ		5	20	mV
Common Mode Rejection Ratio	CMRR		65	80		dB
Power Supply Rejection Ration	PSRR		65	100		dB
Channel Separation	CS	F=1KHZ to 20KHZ		120		dB
Short Circuit Current to Ground	ISC			40	60	mA
Output Current	ISOURCE	VI(+)= 1V,VI(-)=0V VCC=15V,VO(P)=2v	10	30		mA
	ISINK	VI(+)=0V,,VI(-)=1V VCC=15V,VO(P)=2V	10	15		mA
		VI(+)=0V,,VI(-)=1V VCC=15V,VO(P)=200mV	12	100		μA
Differential Input Voltage	VI(DIFF)				VCC	V

Characteristics Curve

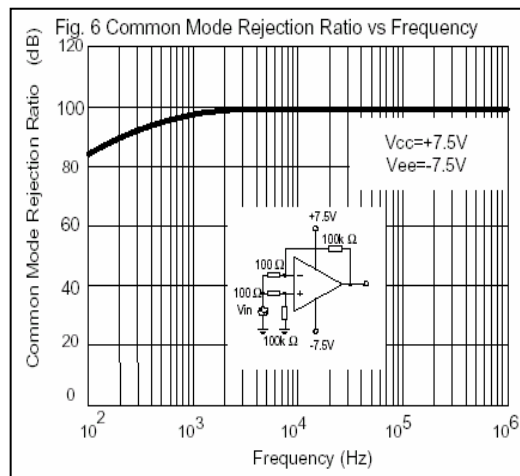
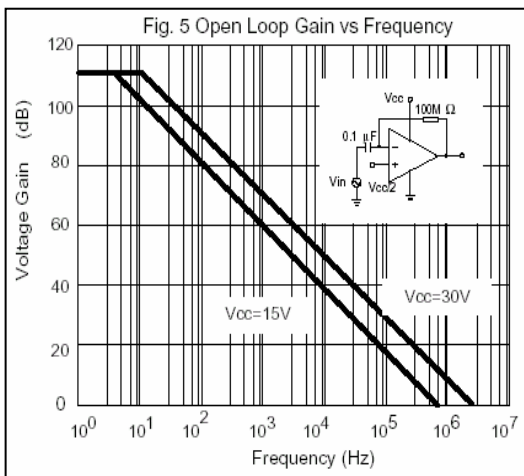
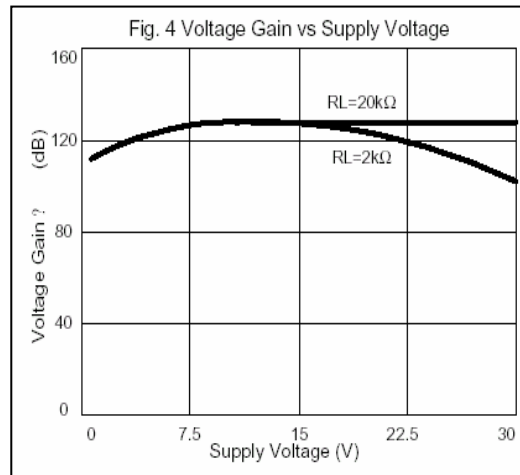
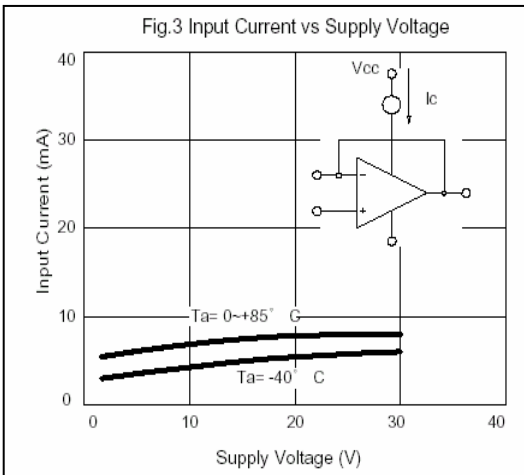
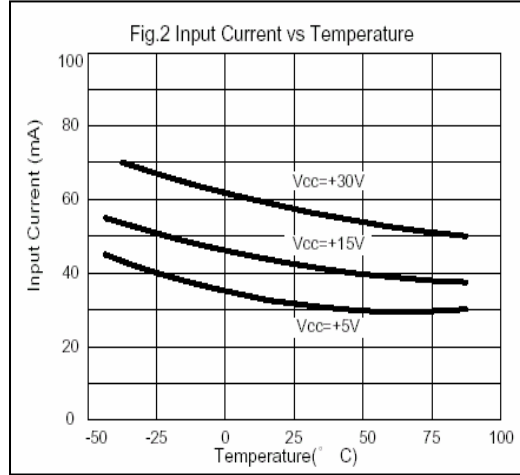
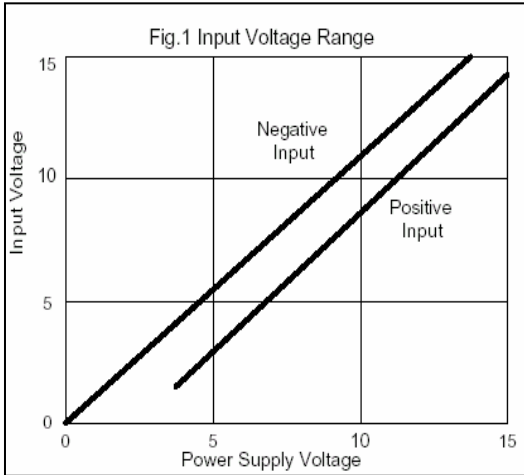

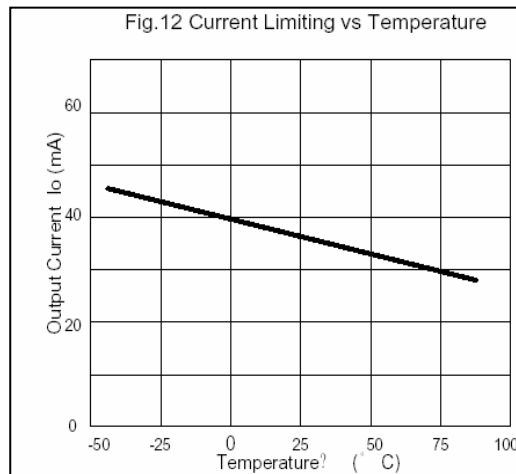
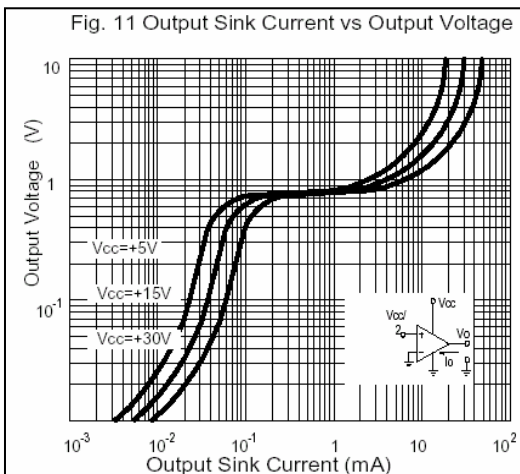
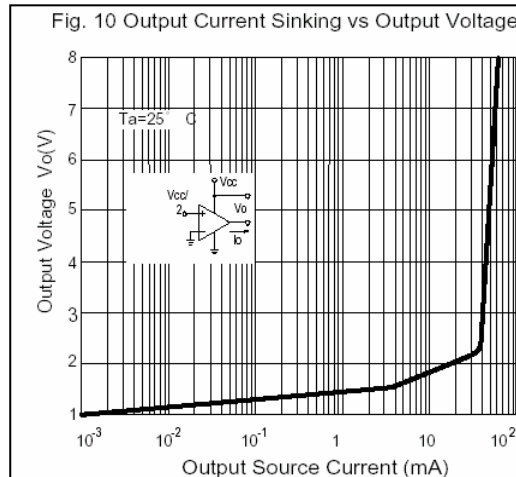
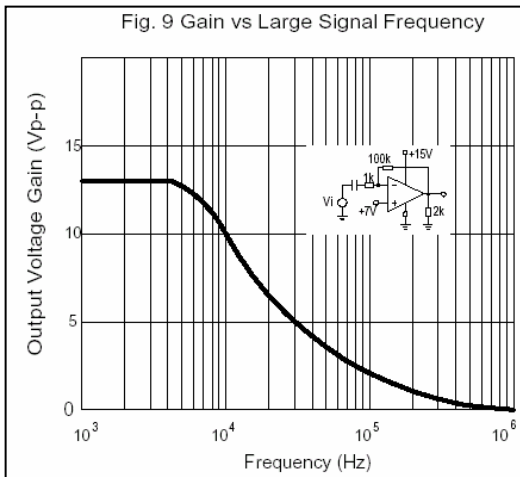
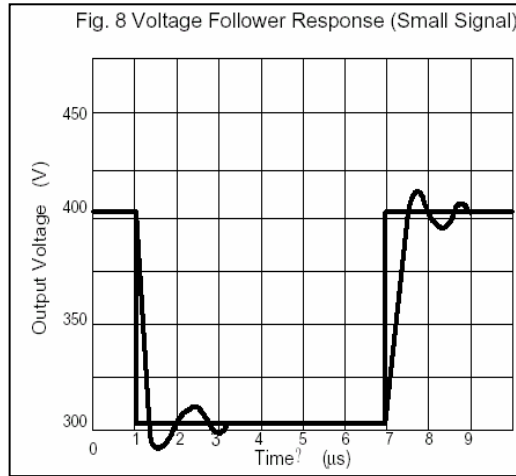
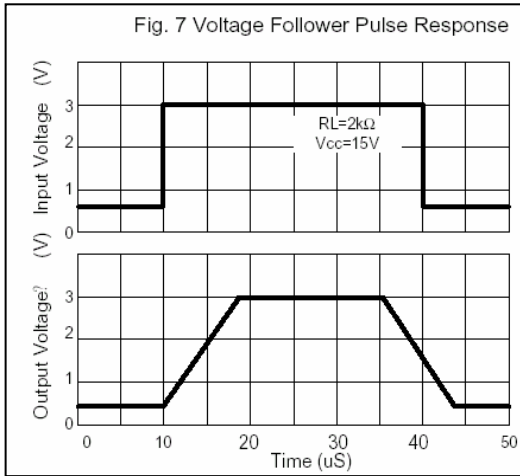

Important Notice:

- All rights are reserved. Reproduction in whole or in part is prohibited without the prior written approval of GTM.
- GTM reserves the right to make changes to its products without notice.
- GTM semiconductor products are not warranted to be suitable for use in life-support Applications, or systems.
- GTM assumes no liability for any consequence of customer product design, infringement of patents, or application assistance.

Head Office And Factory:

- **Taiwan:** No. 17-1 Tatung Rd. Fu Kou Hsin-Chu Industrial Park, Hsin-Chu, Taiwan, R. O. C.
- TEL : 886-3-597-7061 FAX : 886-3-597-9220, 597-0785
- **China:** (201203) No.255, Jang-Jiang Tsai-Lueng RD., Pu-Dung-Hsin District, Shang-Hai City, China
- TEL : 86-21-5895-7671 ~ 4 FAX : 86-21-38950165