

# GPN2222A NPN EPITAXIAL PLANAR TRANSISTOR

## Description

The GPN2222A is designed for general purpose amplifier and high speed, medium-power switching applications.

## Features

- \*Low Collector Saturation Voltage
- \*High Speed Switching
- \*For Complementary Use with PNP Type GPN2907A

## Package Dimensions

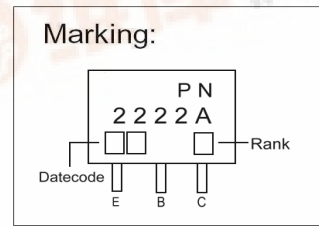
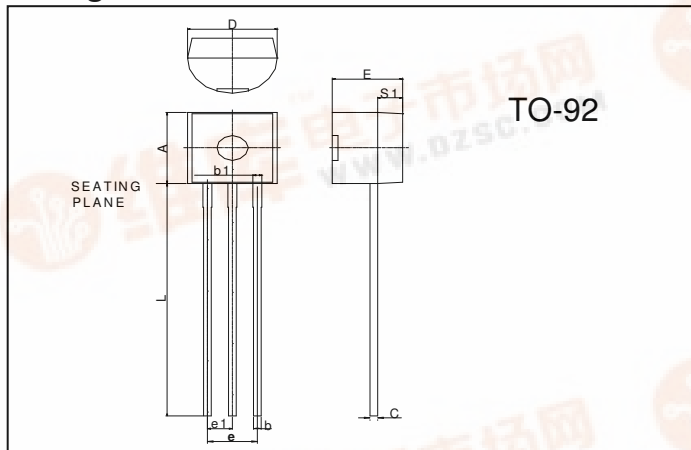

REF.	Millimeter		REF.	Millimeter	
	Min.	Max.		Min.	Max.
A	4.45	4.7	D	4.44	4.7
S1	1.02	-	E	3.30	3.81
b	0.36	0.51	L	12.70	-
b1	0.36	0.76	e1	1.150	1.390
C	0.36	0.51	e	2.42	2.66

## Absolute Maximum Ratings at Ta = 25°C

Parameter	Symbol	Ratings	Unit
Junction Temperature	Tj	+150	°C
Storage Temperature	Tstg	-55 ~ +150	°C
Collector to Base Voltage	VCBO	75	V
Collector to Emitter Voltage	VCEO	40	V
Emitter to Base Voltage	VEBO	6	V
Collector Current	IC	600	mA
Total Power Dissipation	PD	625	mW

## Characteristics at Ta = 25°C

Symbol	Min.	Typ.	Max.	Unit	Test Conditions
BVCBO	75	-	-	V	IC=10uA, IE=0
BVCEO	40	-	-	V	IC=10mA, IB=0
BVEBO	6	-	-	V	IE=10uA, IC=0
ICBO	-	-	10	nA	VCE=60V, IE = 0
ICEX	-	-	10	nA	VCE=60V, VBE(OFF)=3V
IEBO	-	-	50	nA	VEB=3V, IC = 0
*VCE(sat)1	-	-	0.3	V	IC=150mA, IB=15mA
*VCE(sat)2	-	-	1.0	V	IC=500mA, IB=50mA
*VBE(sat)1	-	-	1.2	V	IC=150mA, IB=15mA
*VBE(sat)2	-	-	2	V	IC=500mA, IB=50mA
*hFE1	35	-	-		VCE=10V, IC=100uA
*hFE2	50	-	-		VCE=10V, IC=1mA
*hFE3	75	-	-		VCE=10V, IC=10mA
*hFE4	100	-	300		VCE=10V, IC=150mA
*hFE5	40	-	-		VCE=10V, IC=500mA
*hFE6	50	-	-		VCE=1V, IC=150mA
fT	300	-	-	MHz	VCE=20V, IC=20mA, f=100MHz
Cob	-	-	8	pF	VCB=10V, IE = 0, f=1MHz

\* Pulse Test: Pulse Width ≤ 380us, Duty Cycle ≤ 2%

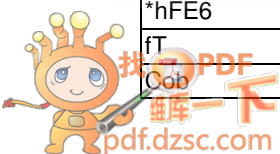

## Characteristics Curve

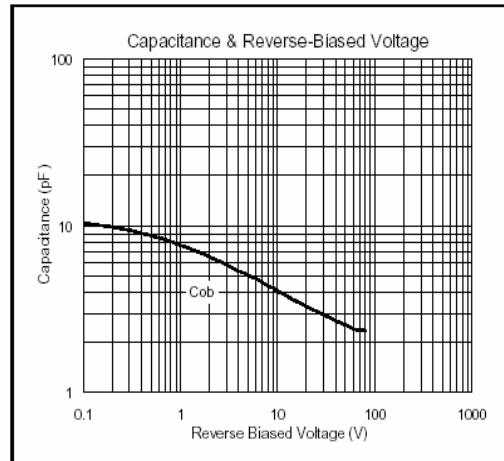
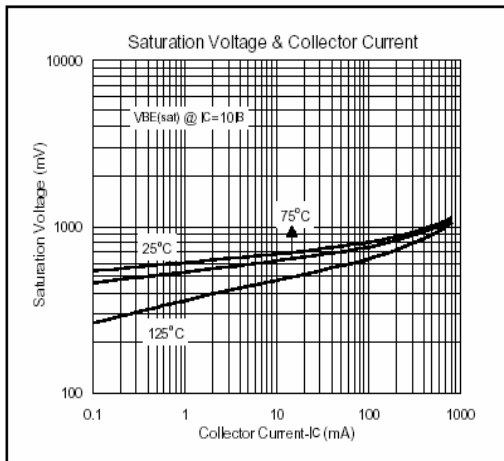
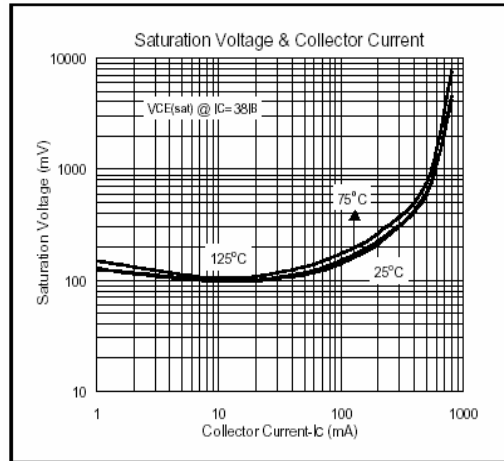
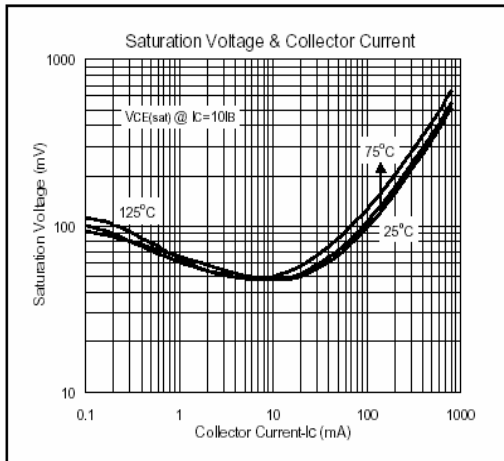
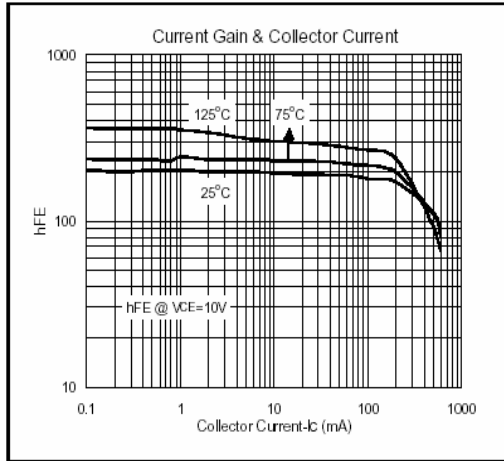
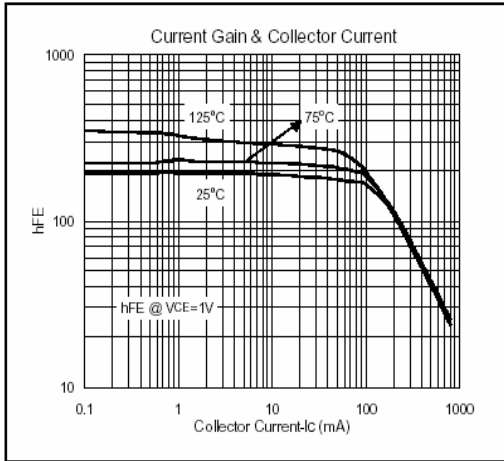

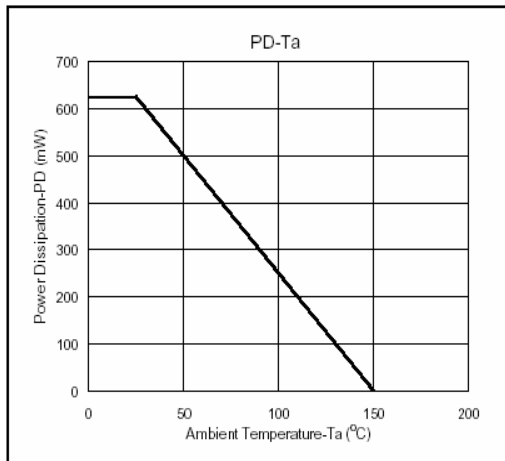
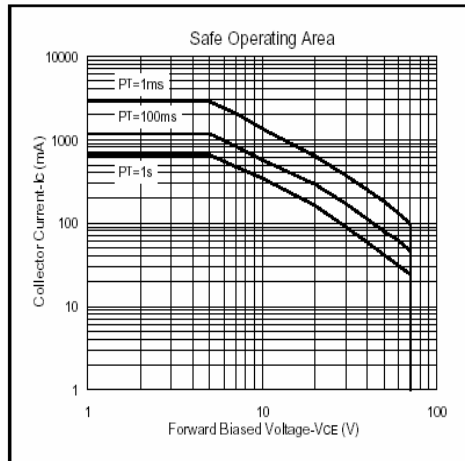
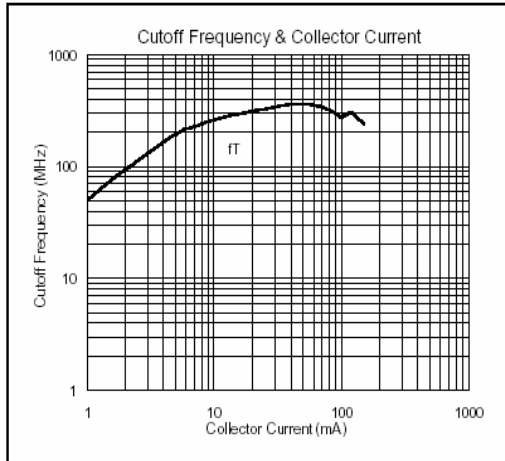

**Important Notice:**

- All rights are reserved. Reproduction in whole or in part is prohibited without the prior written approval of GTM.
- GTM reserves the right to make changes to its products without notice.
- GTM semiconductor products are not warranted to be suitable for use in life-support Applications, or systems.
- GTM assumes no liability for any consequence of customer product design, infringement of patents, or application assistance.

**Head Office And Factory:**

- Taiwan:** No. 17-1 Tatung Rd. Fu Kou Hsin-Chu Industrial Park, Hsin-Chu, Taiwan, R. O. C.  
 TEL : 886-3-597-7061 FAX : 886-3-597-9220, 597-0785
- China:** (201203) No.255, Jang-Jiang Tsai-Lueng RD. , Pu-Dung-Hsin District, Shang-Hai City, China  
 TEL : 86-21-5895-7671 ~ 4 FAX : 86-21-38950165