

GTM CORPORATION

ISSUED DATE :2005/10/26
REVISED DATE :

GSC103 Dual OP-AMP and 2.5V±0.7% Voltage Reference

Description

The GSC103 consists of 2 low-offset voltage amplifiers and a high-accuracy 2.5V voltage reference in SOP-8 package. The GSC103 provides a low cost and space saving solution for the application such as power supply and switching adapters.

The GSC103 is available in a SOP-8 package. It can operate over the ambient temperature range from -40°C to 105°C.

Features

- Precision ±0.7% Voltage Reference
- Vref sinking Current Capability:1mA to 100mA
- Low input Offset Voltage
- Max. 27V Voltage Rating

Applications

- Switching Power Supply
- Adapter
- Portable Device

Package Dimensions

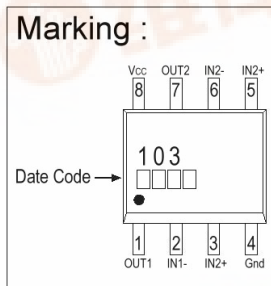
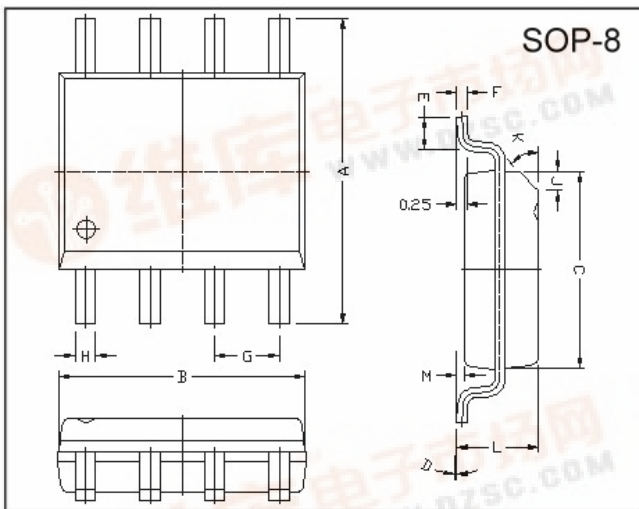

REF.	Millimeter		REF.	Millimeter	
	Min.	Max.		Min.	Max.
A	5.80	6.20	M	0.10	0.25
B	4.80	5.00	H	0.35	0.49
C	3.80	4.00	L	1.35	1.75
D	0°	8°	J	0.375 REF.	
E	0.40	0.90	K	45°	
F	0.19	0.25	G	1.27 TYP.	

Typical Circuit

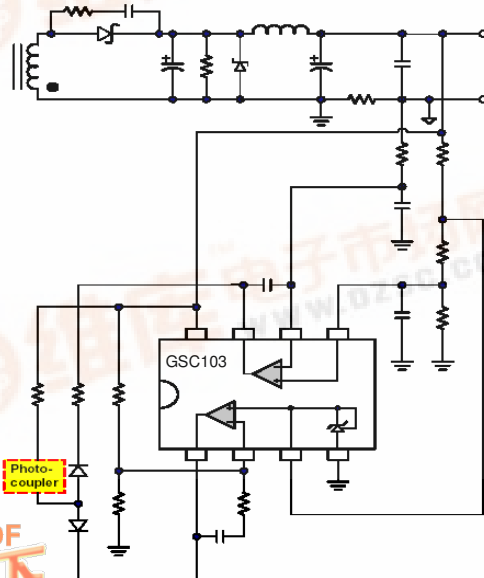

Block Diagram

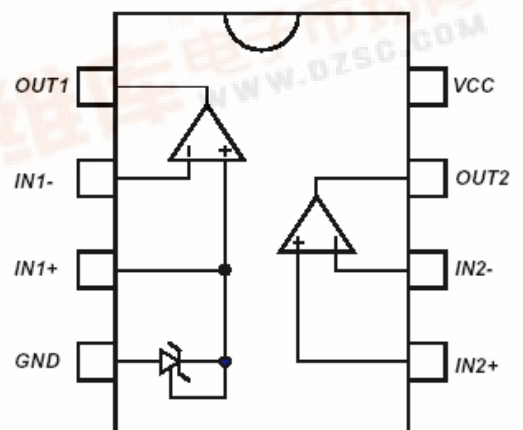

Fig 1. CC/CV Control for Switching Adapters



Pin Descriptions

Pin	Name	Function
1	OUT1	Output of Op-amp 1
2	IN1-	Negative terminal of Op-amp 1
3	IN1+	Positive terminal of Op-amp 1, connected to internal reference voltage
4	GND	Ground
5	IN2+	Positive terminal of Op-amp 2
6	IN2-	Negative terminal of Op-amp 2
7	OUT2	Output of Op-amp 2
8	VCC	Supply voltage

Absolute Maximum Ratings

Parameter	Ratings	Unit
Supply Voltage Vcc	27	V
Differential Input Voltage(IN1+ to IN1-, IN2+ to IN2-)	27	V
Input Voltage	-0.3 ~ Vcc+0.3V	V
Maximum Junction Temperature	150	°C
Operating Ambient Temperature Range	-40 ~ + 105	°C
Storage Temperature Range	-65 ~ + 150	°C
Lead Temperature (PB Free, 10sec)	260	°C
Junction-to-Ambient Thermal Resistance	160	°C/W
ESD Level (Human Body Model)	2k	V

Caution:

Stresses beyond the ratings in "Absolute maximum ratings" may cause permanent damage to the device. This is a stress only rating and operation of device at these or any other conditions above those indicated in the operational sections of this specification is not limited.

Electrical Characteristics

Parameter	Test Conditions	Min	Typ	Max	Unit
Total Supply Current (No Load)	Vcc=5V, -40°C~105°C	-	0.7	1.2	mA
	Vcc=27V, -40°C~105°C	-	-	2	

(Vcc=+5V, TA=+25°C unless otherwise stated)

Parameter	Test Conditions	Min	Typ	Max	Unit
OP-Amp1 & OP-Amp2					
Input Offset Voltage (Common mode Voltage=0V)	25°C	-	1	4	mV
	-40°C~105°C	-	-	5	
Input Offset Voltage Drift		-	7	-	µV/°C
Input Bias Current (OP1)	25°C	-	20	-	nA
Input Bias Current (OP2)	25°C	-	20	150	nA
	-40°C~105°C	-	-	200	
Output Source Current	Vcc=15V, Vo=2V Differential Input Voltage=1V	20	40	-	mA
Output Sink Current	Vcc=15V, Vo=2V Differential Input Voltage=-1V	10	-	-	mA
	Vcc=15V, Vo=0.2V Differential Input Voltage=-1V	12	50	-	µA
Output Short Current	Vcc=15V	-	40	60	mA
Output Voltage – High Level	Vcc=27V, RL=2kΩ, 25°C	23	24	-	V
	Vcc=27V, RL=2kΩ, -40°C~105°C	23	-	-	
	Vcc=27V, RL=10kΩ, 25°C	24	-	-	
	Vcc=27V, RL=10kΩ, -40°C~105°C	24	25	-	
Output Voltage – Low Level	RL=10kΩ, 25°C	-	5	20	mV
	RL=10kΩ, -40°C~105°C	-	-	20	
Large Signal Voltage Gain (OP1)	Common mode Voltage=0V Vcc=15V, RL=2kΩ	-	100	-	V/mV
	Vo=1.4V~11.4V, -40°C~105°C				
Large Signal Voltage Gain (OP2)	Vcc=15V, RL=2kΩ, Vo=1.4V~11.4V, 25°C	50	100	-	V/mV
	Vcc=15V, RL=2kΩ, Vo=1.4V~11.4V, -40°C~105°C	25	-	-	

GTM CORPORATION

ISSUED DATE :2005/10/26
REVISED DATE :

Slew Rate at Unity Gain	$V_{IN}=0.5V\sim 2V$, $V_{CC}=15V$ $R_L=2k\Omega$, $C_L=100pF$, Unity Gain	0.2	0.4	-	$V/\mu S$
Supply Voltage Rejection Ratio	Common mode Voltage=0V, $V_{CC}=5\sim 27V$	65	100	-	dB
Gain Bandwidth Product	$V_{CC}=27V$, $R_L=2k\Omega$, $C_L=100pF$, $f=100kHz$, $V_{IN}=10mV$	0.5	0.9	-	MHz
Total Harmonic Distortion	$V_{CC}=27V$, $R_L=2k\Omega$, $C_L=100pF$ $V_O=2V_{PP}$, $f=1kHz$, $A_V=20dB$	-	0.02	-	%
OP-Amp2					
Input Offset Current	25°C	-	2	75	nA
	-40°C ~105°C	-	-	150	
Input Common Mode Voltage Range	$V_{CC}=27V$, 25°C	0	-	$V_{CC}-1.5$	V
	$V_{CC}=27V$, -40°C ~105°C	0	-	$V_{CC}-2$	
Common Mode Rejection Ratio	25°C	70	85	-	dB
	-40°C ~105°C	60	-	-	
Equivalent Input Noise Voltage	$f=1kHz$, $R_s=100\Omega$, $V_{CC}=27V$	-	50	-	nV/\sqrt{Hz}
Reference Voltage					
Cathode Current		1	-	100	mA
Reference Voltage ($I_k=10mA$)	25°C	2.482	2.500	2.518	V
	-40°C ~105°C	2.465	2.500	2.535	
Reference Input Voltage Deviation Over Temperature Range($I_k=10mA$)	-40°C ~105°C	-	7	30	mV
Minimum Cathode Current for Regulator		-	0.5	1	mA
Dynamic Impedance	$\Delta I_k=1\sim 100mA$, $f<1kHz$	-	0.2	0.5	Ω

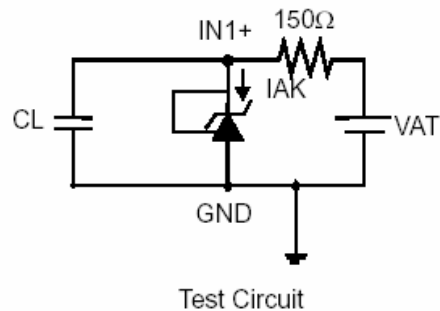
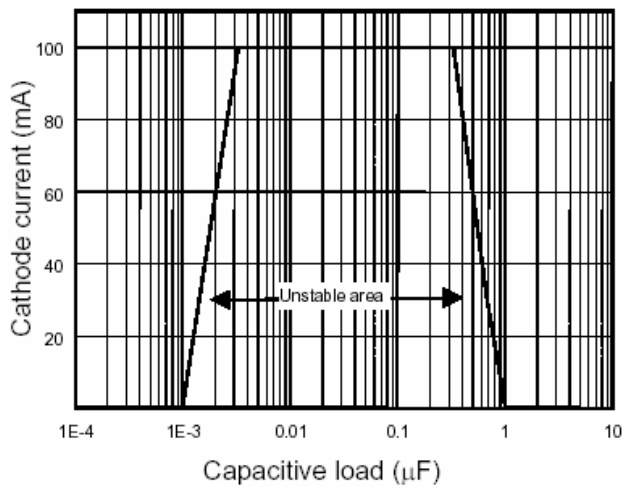

Application Information—CC/CV Control for Switching Adapters

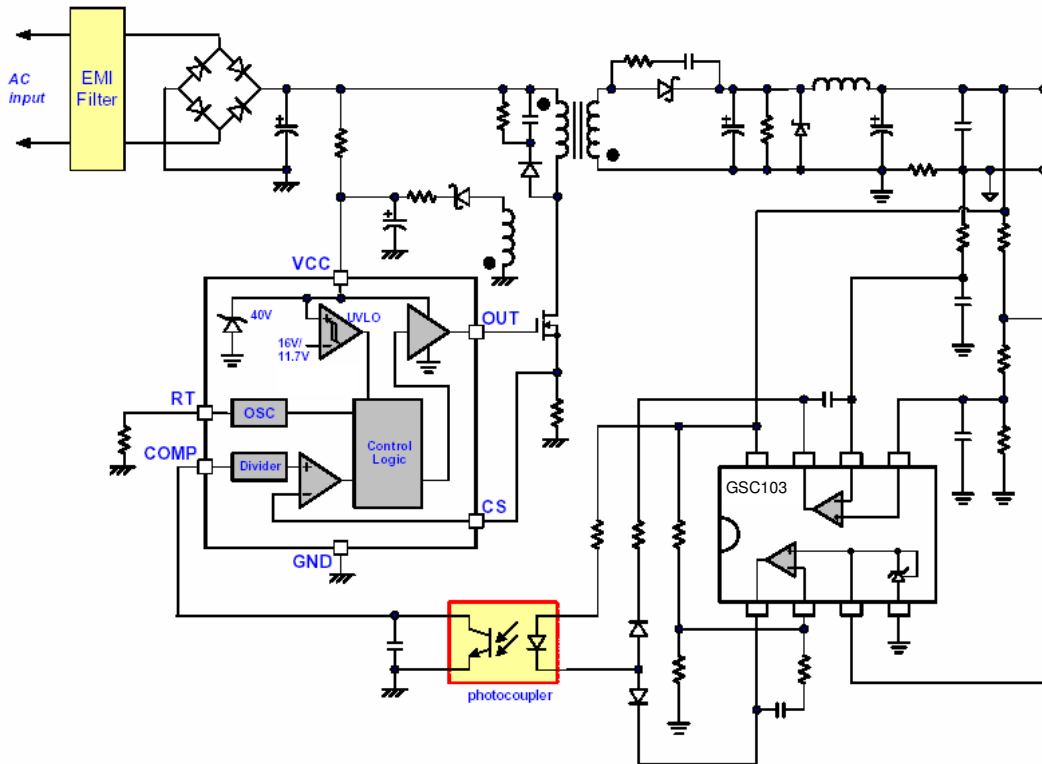

Important Notice:

- All rights are reserved. Reproduction in whole or in part is prohibited without the prior written approval of GTM.
- GTM reserves the right to make changes to its products without notice.
- GTM semiconductor products are not warranted to be suitable for use in life-support Applications, or systems.
- GTM assumes no liability for any consequence of customer product design, infringement of patents, or application assistance.

Head Office And Factory:

- **Taiwan:** No. 17-1 Tatung Rd. Fu Kou Hsin-Chu Industrial Park, Hsin-Chu, Taiwan, R. O. C.
- TEL : 886-3-597-7061 FAX : 886-3-597-9220, 597-0785
- **China:** (201203) No.255, Jang-Jiang Tsai-Lueng RD. , Pu-Dung-Hsin District, Shang-Hai City, China
- TEL : 86-21-5895-7671 ~ 4 FAX : 86-21-38950165